

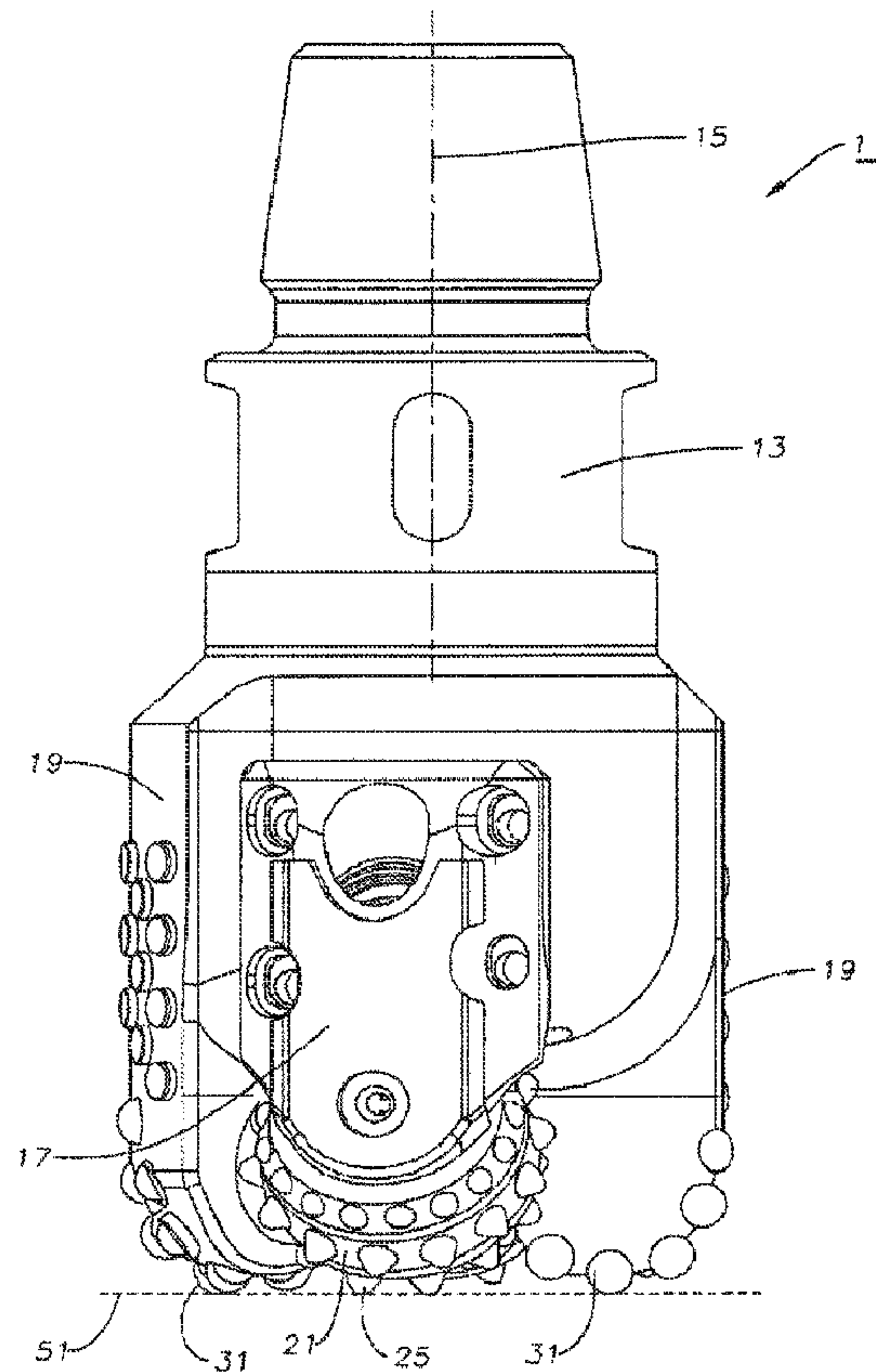

(86) Date de dépôt PCT/PCT Filing Date: 2010/04/27  
 (87) Date publication PCT/PCT Publication Date: 2010/11/11  
 (45) Date de délivrance/Issue Date: 2014/07/08  
 (85) Entrée phase nationale/National Entry: 2011/10/27  
 (86) N° demande PCT/PCT Application No.: US 2010/032511  
 (87) N° publication PCT/PCT Publication No.: 2010/129253  
 (30) Priorité/Priority: 2009/04/28 (US12/431,570)

(51) Cl.Int./Int.Cl. *E21B 10/14* (2006.01),  
*E21B 10/12* (2006.01), *E21B 10/16* (2006.01)  
 (72) Inventeurs/Inventors:  
TURNER, EVAN C., US;  
SULLIVAN, ERIC, US  
 (73) Propriétaire/Owner:  
BAKER HUGHES INCORPORATED, US  
 (74) Agent: SIM & MCBURNEY

(54) Titre : CONCEPT DE COMMANDE ADAPTATIF POUR TREPANS A CONE DE ROULEMENT/PDC HYBRIDE  
 (54) Title: ADAPTIVE CONTROL CONCEPT FOR HYBRID PDC/ROLLER CONE BITS



(57) Abrégé/Abstract:

An earth boring drill bit comprising a bit body having a longitudinal axis along a path of the bit, a first plurality of cutters mounted to the body, and a second plurality of cutters rotatably mounted to the body, wherein a longitudinal axial relationship between the first



(57) **Abrégé(suite)/Abstract(continued):**

plurality of cutters and the second plurality of cutters is adjustable. The first and/or second plurality of cutters may be mounted to the body in such a manner as to allow them to slide parallel to the longitudinal axis. The longitudinal axial relationship may be adjusted to exchange the first plurality of cutters and the secondary plurality of cutters between a primary cutting position and a secondary cutting position. The bit may include a sensor to provide an indication of a formation type being excavated by the bit and a processor to control the longitudinal axial relationship based on the indication.

(12) INTERNATIONAL APPLICATION PUBLISHED UNDER THE PATENT COOPERATION TREATY (PCT)

(19) World Intellectual Property Organization  
International Bureau(43) International Publication Date  
11 November 2010 (11.11.2010)(10) International Publication Number  
**WO 2010/129253 A4**

(51) International Patent Classification:

*E21B 10/14* (2006.01)      *E21B 10/16* (2006.01)  
*E21B 10/12* (2006.01)

77380 (US). SULLIVAN, Eric [US/US]; 9110 Grogans Mill Rd., The Woodlands, TX 77380 (US).

(21) International Application Number:

PCT/US2010/032511

(74) Agents: WELBORN, Brian, S. et al.; Baker Hughes Incorporated, Intellectual Property Counsel, P.O. Box 4740, Houston, TX 77210-4740 (US).

(22) International Filing Date:

27 April 2010 (27.04.2010)

(81) Designated States (*unless otherwise indicated, for every kind of national protection available*): AE, AG, AL, AM, AO, AT, AU, AZ, BA, BB, BG, BH, BR, BW, BY, BZ, CA, CH, CL, CN, CO, CR, CU, CZ, DE, DK, DM, DO, DZ, EC, EE, EG, ES, FI, GB, GD, GE, GH, GM, GT, HN, HR, HU, ID, IL, IN, IS, JP, KE, KG, KM, KN, KP, KR, KZ, LA, LC, LK, LR, LS, LT, LU, LY, MA, MD, ME, MG, MK, MN, MW, MX, MY, MZ, NA, NG, NI, NO, NZ, OM, PE, PG, PH, PL, PT, RO, RS, RU, SC, SD, SE, SG, SK, SL, SM, ST, SV, SY, TH, TJ, TM, TN, TR, TT, TZ, UA, UG, US, UZ, VC, VN, ZA, ZM, ZW.

(25) Filing Language:

English

(26) Publication Language:

English

(30) Priority Data:

12/431,570      28 April 2009 (28.04.2009)      US

(71) Applicant (*for all designated States except US*): BAKER HUGHES INCORPORATED [US/US]; P.O. Box 4740, Houston, TX 77210 (US).

(72) Inventors; and

(75) Inventors/Applicants (*for US only*): TURNER, Evan, C. [US/US]; 9110 Grogans Mill Rd., The Woodlands, TX(84) Designated States (*unless otherwise indicated, for every kind of regional protection available*): ARIPO (BW, GH, GM, KE, LR, LS, MW, MZ, NA, SD, SL, SZ, TZ, UG, ZM, ZW), Eurasian (AM, AZ, BY, KG, KZ, MD, RU, TJ, TM), European (AT, BE, BG, CH, CY, CZ, DE, DK, EE,

[Continued on next page]

(54) Title: ADAPTIVE CONTROL CONCEPT FOR HYBRID PDC/ROLLER CONE BITS

FIG. 1

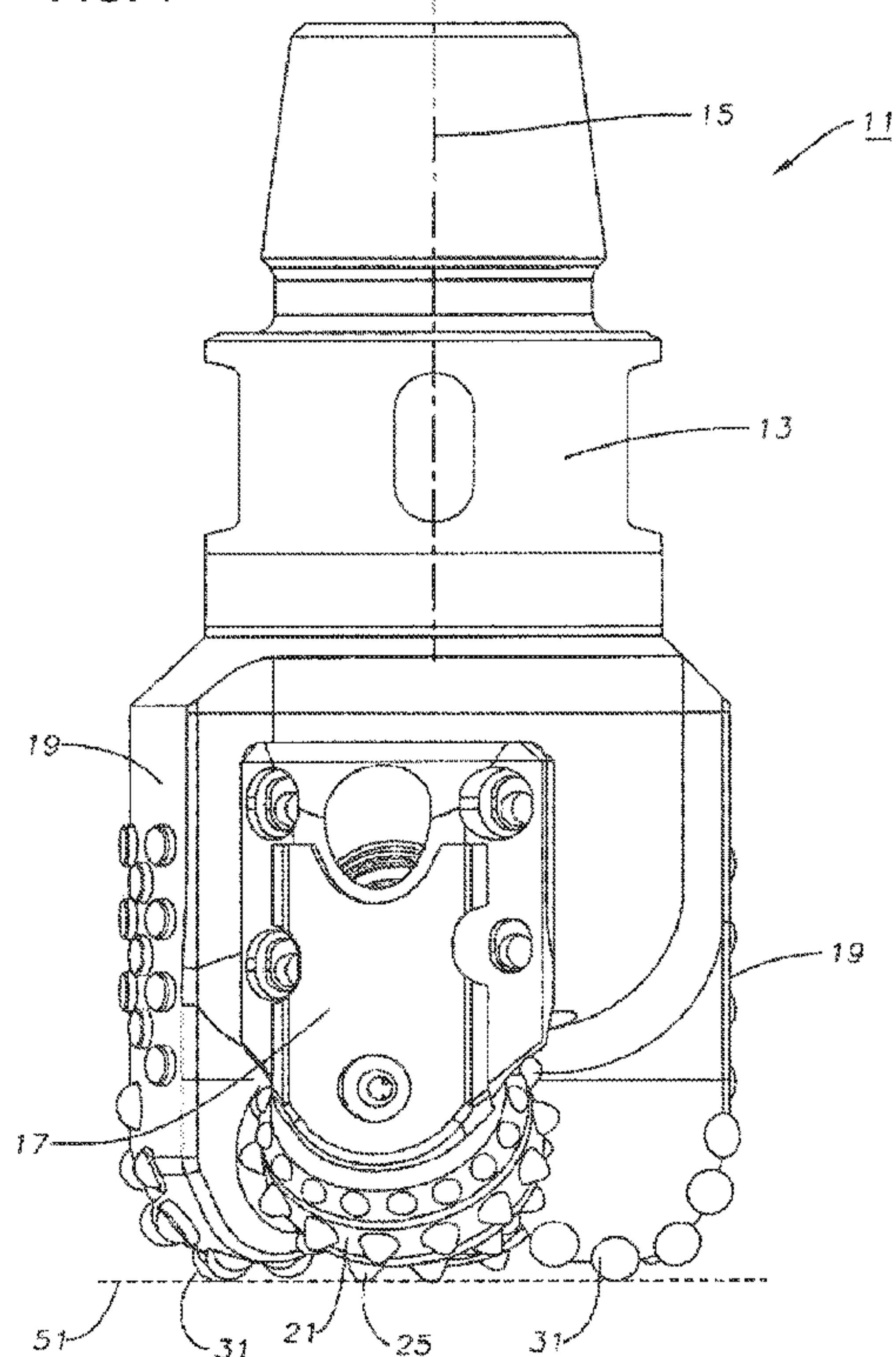

(57) Abstract: An earth boring drill bit comprising a bit body having a longitudinal axis along a path of the bit, a first plurality of cutters mounted to the body, and a second plurality of cutters rotatably mounted to the body, wherein a longitudinal axial relationship between the first plurality of cutters and the second plurality of cutters is adjustable. The first and/or second plurality of cutters may be mounted to the body in such a manner as to allow them to slide parallel to the longitudinal axis. The longitudinal axial relationship may be adjusted to exchange the first plurality of cutters and the secondary plurality of cutters between a primary cutting position and a secondary cutting position. The bit may include a sensor to provide an indication of a formation type being excavated by the bit and a processor to control the longitudinal axial relationship based on the indication.

- 1 -

## TITLE OF THE INVENTION

Adaptive Control Concept for Hybrid PDC/Roller Cone Bits

## CROSS REFERENCE TO RELATED APPLICATIONS

5 None.

## STATEMENT REGARDING FEDERALLY SPONSORED RESEARCH OR DEVELOPMENT

Not applicable.

10

## REFERENCE TO APPENDIX

Not applicable.

## BACKGROUND OF THE INVENTION

15

Field of the Invention. The inventions disclosed and taught herein relate generally to earth boring drill bits; and more specifically relate to hybrid PDC/roller cone earth boring drill bits.

## Description of the Related Art.

20

U.S. Patent No. 4,343,371 discloses a "hybrid rock bit ... wherein a pair of opposing extended nozzle drag bit legs are positioned adjacent a pair of opposed tungsten carbide roller cones. The extended nozzle face nearest the hole bottom has a multiplicity of diamond inserts mounted therein. The diamond inserts are strategically positioned to remove the ridges between the kerf rows in the hole bottom formed by the inserts in the roller cones."

25

U.S. Patent No. 7,398,837 discloses a "drill bit assembly [that] has a body portion intermediate a shank portion and a working portion. The working portion has at least one cutting element. In some embodiments, the drill bit assembly has a shaft with an end substantially coaxial to a central axis of the assembly. The end of the shaft substantially protrudes from the working portion, and at least one downhole logging device is disposed within or in communication with the shaft."

30

U. S. Patent No. 7,350,568 discloses a "method for logging a well. Includes receiving energy with at least one array of elements coupled to a drill bit, wherein the at least one array of elements functions as an electronic array. An apparatus for logging a well includes a drill bit and at least one array of elements coupled to the drill bit, wherein the at least one array of elements functions as an electronic array."

The inventions disclosed and taught herein are directed to an improved hybrid PDC/roller cone earth boring drill bit.

#### 10 BRIEF SUMMARY OF THE INVENTION

Accordingly, in one aspect there is provided a earth boring drill bit comprising: a bit body having a longitudinal axis along a path of the bit; a first plurality of cutters mounted to the body; a second plurality of cutters rotatably mounted to the body, wherein a longitudinal axial relationship between the first plurality of cutters and the second plurality of cutters is adjustable; a sensor providing an indication of a formation type being excavated by the bit; and a processor programmed to control the longitudinal axial relationship based on the indication.

The first and/or second plurality of cutters may be mounted to the body in such a manner as to allow them to move essentially parallel to the longitudinal axis. The longitudinal axial relationship may be adjusted to exchange the first plurality of cutters and the secondary plurality of cutters between a primary cutting position and a secondary cutting position.

According to another aspect there is provided an earth boring drill bit assembly comprising: a bit body having a longitudinal axis along a path of the bit; a first plurality of cutters mounted to the body; a second plurality of cutters rotatably mounted to the body; a sensor providing an indication of a formation type adjacent the body; and a processor programmed to control a longitudinal axial relationship between the first plurality of cutters and the second plurality of cutters based on the indication.

- 2a -

According to yet another aspect there is provided a method of drilling a borehole in an earth formation, the method comprising the steps of: receiving an indication of a formation type adjacent a drill bit from a sensor located within the borehole; and triggering an actuator to adjust a longitudinal axial relationship between a polycrystalline diamond compact (PDC) cutter and a roller cone cutter located on the bit in response to a processor programmed to analyze the indication.

According to still yet another aspect there is provided a earth boring drill bit assembly comprising: a bit body having a longitudinal axis along a path of the bit; at least one blade mounted to the body; a first plurality of cutters fixedly mounted to the blade; at least one leg mounted to the body; a second plurality of cutters rotatably mounted to the leg; a sensor providing an indication of a formation type adjacent the body; and a processor internal to the body and programmed to control a longitudinal axial relationship between the first plurality of cutters and the second plurality of cutters to exchange the first plurality of cutters and the secondary plurality of cutters between a primary cutting position and a secondary cutting position based on the indication.

#### BRIEF DESCRIPTION OF THE SEVERAL VIEWS OF THE DRAWINGS

Figure 1 illustrates a first elevation view of a particular embodiment of an earth boring drill bit utilizing certain aspects of the present inventions;

Figure 2 illustrates a second elevation view of a particular embodiment of an earth boring drill bit utilizing certain aspects of the present inventions;

Figure 3 illustrates a third elevation view of a particular embodiment of an earth boring drill bit utilizing certain aspects of the present inventions;

- 3 -

Figure 4 illustrates a fourth elevation view of a particular embodiment of an earth boring drill bit utilizing certain aspects of the present inventions;

Figure 5 illustrates a first simplified partial block diagram of a particular embodiment of an earth boring drill bit utilizing certain aspects of the present inventions; and

Figure 6 illustrates a second simplified partial block diagram of a particular embodiment of an earth boring drill bit utilizing certain aspects of the present inventions.

#### DETAILED DESCRIPTION

The Figures described above and the written description of specific structures and functions below are not presented to limit the scope of what Applicants have invented or the scope of the appended claims. Rather, the Figures and written description are provided to teach any person skilled in the art to make and use the inventions for which patent protection is sought. Those skilled in the art will appreciate that not all features of a commercial embodiment of the inventions are described or shown for the sake of clarity and understanding. Persons of skill in this art will also appreciate that the development of an actual commercial embodiment incorporating aspects of the present inventions will require numerous implementation-specific decisions to achieve the developer's ultimate goal for the commercial embodiment. Such implementation-specific decisions may include, and likely are not limited to, compliance with system-related, business-related, government-related and other constraints, which may vary by specific implementation, location and from time to time. While a developer's efforts might be complex and time-consuming in an absolute sense, such efforts would be, nevertheless, a routine undertaking for those of skill in this art having benefit of this disclosure. It must be understood that the inventions disclosed and taught herein are susceptible to numerous and various modifications and alternative forms. Lastly, the use of a singular term, such as, but not limited to, "a," is not intended as limiting of the number of items. Also, the use of relational terms, such as, but not limited to, "top," "bottom," "left," "right," "upper," "lower,"

- 4 -

"down," "up," "side," and the like are used in the written description for clarity in specific reference to the Figures and are not intended to limit the scope of the invention or the appended claims.

Particular embodiments of the invention may be described below with reference to block diagrams and/or operational illustrations of methods. It will be understood that each block of the block diagrams and/or operational illustrations, and combinations of blocks in the block diagrams and/or operational illustrations, can be implemented by analog and/or digital hardware, and/or computer program instructions. Such computer program instructions may be provided to a processor of a general-purpose computer, special purpose computer, ASIC, and/or other programmable data processing system. The executed instructions may create structures and functions for implementing the actions specified in the block diagrams and/or operational illustrations. In some alternate implementations, the functions/actions/structures noted in the figures may occur out of the order noted in the block diagrams and/or operational illustrations. For example, two operations shown as occurring in succession, in fact, may be executed substantially concurrently or the operations may be executed in the reverse order, depending upon the functionality/acts/structure involved.

Computer programs for use with or by the embodiments disclosed herein may be written in an object oriented programming language, conventional procedural programming language, or lower-level code, such as assembly language and/or microcode. The program may be executed entirely on a single processor and/or across multiple processors, as a stand-alone software package or as part of another software package.

Applicants have created an earth boring drill bit comprising a bit body having a longitudinal axis along a path of the bit, a first plurality of cutters mounted to the body, and a second plurality of cutters rotatably mounted to the body, wherein a longitudinal axial relationship between the first plurality of cutters and the second plurality of cutters is adjustable. The first and/or second plurality of cutters may be mounted to the body in such a manner as to allow them to move essentially parallel to the longitudinal axis. The longitudinal

axial relationship may be adjusted to exchange the first plurality of cutters and the secondary plurality of cutters between a primary cutting position and a secondary cutting position. The bit may include one or more sensors to provide an indication of a formation type being excavated by the bit and a processor to control the longitudinal axial relationship based on the indication.

5 FIG. 1 is an illustration of a hybrid bit 11 that incorporates both rolling cones and fixed polycrystalline diamond compact (PDC) cutters mounted on dual cutting structures, similar to those shown in U.S. Patent No. 4,343,371 and U.S. Patent Application Publication No. 20080296068. More specifically,

10 referring also to FIG. 2, the bit 11 comprises a bit body 13 having a longitudinal axis 15 that defines an axial center of the bit body 13. A plurality of roller cone support arms 17 extend from the bit body 13 in the longitudinal axial direction. The bit body 13 also has a plurality of blades 19 that extend in the longitudinal axial is direction. The number of each of arms 17 and blades

15 19 is at least one but may be more than two.

Roller cones 21 are mounted to respective ones of the arms 17. A plurality of roller cone cutting inserts or cutters 25 are mounted to the roller cones 21. In this manner, the roller cone cutters 25 are rotatably mounted to the bit body 13. In addition, a plurality of fixed cutting elements 31, such as PDC cutters,

20 are mounted to the blades 19. Examples of roller cone cutting elements 25 and fixed cutting elements 31 include tungsten carbide inserts, cutters made of super hard material such as polycrystalline diamond, and others known to those skilled in the art.

FIG. 1 and FIG. 2 show both the roller cone cutting elements 25 and fixed cutting elements 31 in a neutral position or relationship with regard to the longitudinal axis 15. In this position, the roller cone cutting elements 25 and fixed cutting elements 31 overlap and complement each other.

25

However, certain formation types favor the roller cone cutting elements 25 over the fixed cutting elements 31, or vice versa. For example, the roller cone cutting elements 25 are often better suited to dense rock formations, whereas

30 the fixed cutting elements 31 may be better suited to softer or more

- 6 -

homogeneous formations. Therefore, it is best to match the drill bit type to the formation type the bit 11 is expected to encounter. To further complicate matters, the drill bit 11 may encounter many different formation types while excavating a single well or borehole.

5 Therefore, the drill bit 11 of the present invention is preferably adjustable, such that either the roller cone cutting elements 25 or the fixed cutting elements 31 may be primary, with the other being secondary. In other words, the drill bit 11 of the present invention is preferably adjustable, such that either the roller cone cutting elements 25 may be in a primary cutting position, with the fixed cutting elements 31 in a secondary cutting position, and vice versa.

10 The present invention's ability to exchange the roller cone cutting elements 25 and the fixed cutting elements 31 between the primary cutting position and the secondary cutting position ensures that the formation is drilled, or excavated, as efficiently as possible with the least amount of wear on the bit 10. This ability to vary which elements 25,31 are primary and secondary may also improve the steerability of the bit 10 and bottom hole assembly (BHA) in varying formations.

15 In one embodiment, this adjustability is provided by mounting the roller cone cutting elements 25 and/or the fixed cutting elements 31 on the bit body 13 in such a manner as to allow them to be moved, or shifted, essentially parallel to the longitudinal axis 15 of the bit 11. In another embodiment, this adjustability is provided by mounting the arms 17 and/or the blades 19 on the bit body 13 in such a manner as to allow them to be moved essentially parallel to the longitudinal axis 15 of the bit 11. In one embodiment, the movement is essentially a linear shifting, or sliding, of the arms 17 and/or the blades 19 along the bit body 13, such as through the use of a track, rail, channel, or groove system. However, other forms of movement may be used and the movement may involve more than simple displacement along the longitudinal axis 15 of the bit 11. For example, the arms 17 and/or the blades 19 may be spirally, or helically, mounted on the bit body 13, such that the movement is a corkscrew motion about the body 13 of the bit 10. In still other embodiments, the movement may be even more complex. For example, the body 13 and

- 7 -

the arms 17 and/or the blades 19 may have locking notched or toothed surfaces therebetween to prevent the arms 17 and/or the blades 19 from sliding with respect to the body 13, such that the arms 17 and/or the blades 19 move away from the body 13, slide, or shift, along the axis 15, and then move back toward the body 13. In any case, a longitudinal axial relationship between the roller cone cutting elements 25 and the fixed cutting elements 31 may be adjusted, such that the roller cone cutting elements 25 are in the primary cutting position, with the fixed cutting elements 31 in the secondary cutting position, or vice versa.

In this manner, the drill bit 11 of the present invention may be matched to the formation type being excavated. It should be understood that the primary cutting position is slightly deeper in the borehole than the secondary cutting position. This adjustment, or relative position/movement, may vary depending on many factors, such as bit or BHA design or application and/or the formation. In one embodiment, there may be approximately one eighth inch difference between the primary cutting position and the secondary cutting position. In other embodiments, this difference, adjustment, or movement, may be between one and two hundredths of an inch. In still other embodiments, this difference, adjustment, or movement, may be between three thousandths of an inch and one quarter inch. Finally, in some embodiments, the bit 10 may accommodate more than one eighth of an inch of relative movement.

For example, as shown in FIG. 3, the arms 17 may be extended such that the roller cone cutting elements 25 extend beyond, or are deeper than, a cutting depth 51 of the fixed cutting elements 31 mounted on the blades 19. In the configuration shown in FIG. 3, the roller cone cutting elements 25 are in the primary cutting position, with the fixed cutting elements 31 in the secondary cutting position. Alternatively, as shown in FIG. 4, the arms 17 may be retracted such that the roller cone cutting elements 25 do not extend to, or are shallower than, the cutting depth 51 of the fixed cutting elements 31 mounted on the blades 19. In the configuration, shown in FIG. 4, the fixed

- 8 -

cutting elements 31 are in the primary cutting position, with the roller cone cutting elements 25 in the secondary cutting position.

Such adjustment may be accomplished manually or automatically, at the surface or with the bit 11 in the borehole. This adjustment may be accomplished while actively drilling during a pause in drilling. For example, the bit 10 may be lifted off the More specifically, as shown in FIG. 5 and FIG. 6, in some embodiments, one or more sensors 61 provide some indication of the formation type being excavated by the bit 11 and a processor 65 controls the longitudinal axial relationship between the roller cone cutting elements 25, the fixed cutting elements 31, and/or the bit body 13 based on the indication.

For example, as shown in FIG. 5, the sensors 61 may sense a relatively soft formation type and provide an indication of the formation type to the processor 65. The processor 65 may decide to place the fixed cutting elements 31 in the primary cutting position and/or place the roller cone cutting elements 25 in the secondary cutting position. To do so, in some embodiments, the processor 65 triggers one or more actuators 67, causing the actuators 67 to retract the arms 17, thereby placing the roller cone cutting elements 25 in the secondary cutting position and the fixed cutting elements 31 in the primary cutting position.

Alternatively, as shown in FIG. 6, the sensor 61 may sense a relatively hard formation type and provide an indication of the formation type to the processor 65. The processor 65 may decide to place the roller cone cutting elements 25 in the primary cutting position and/or place the fixed cutting elements 31 in the secondary cutting position. To do so, in some embodiments, the processor 65 triggers the actuators 67, causing the actuators 67 to extend the arms 17, thereby placing the roller cone cutting elements 25 in the primary cutting position and the fixed cutting elements 31 in the secondary cutting position.

In this manner, the bit 11 of the present invention may exchange the fixed cutting elements 31 and the roller cone cutting elements 25 between the primary cutting position and the secondary cutting position. In other words, the longitudinal axial relationship between the first plurality of cutters and the second plurality of cutters may be adjusted in this manner. This exchange, or

- 9 -

adjustment, may occur many times during excavation of a single borehole. Furthermore, this exchange, or adjustment, may be accomplished automatically, with or without intervention from an operator or external systems. Therefore, the sensor 61, the processor 65, and/or the actuators 67  
5 may be internal to, or integral with, the bit 11. Alternatively, the sensor 61, the processor 65, and/or the actuators 67 may be external to the bit 11. For example, the sensors 61 and/or the processor 65 may be mounted within the bit body 13, in a shank of the bit 11, in a sub behind or above the bit 11, or be part of a measurement or logging while drilling (MWD) tool or a near bit  
10 resistivity tool. In one embodiment, the sensors 61 are placed as close to the cutting elements 25,31, or bit face, as possible in order to provide the formation type change indication as quickly as possible. However, sensors 61 in the bit shank and/or elsewhere in the BHA may provide the formation type indication soon enough for efficient operation, while keeping the sensors 61  
15 protected.

The sensor(s) 61 may be gamma ray, resistivity, sonic, or other downhole real time sensors used to recognize formation changes and/or the current formation type being drilled. The formation type indication, formation type determination, and/or and indication of the relative positions of the fixed  
20 cutting elements 31 and the roller cone cutting elements 25 may be communicated to the surface. A operator at the surface may review this data and determine whether the positions need to be exchanged and communicate a command to the processor 65 and/or directly trigger the actuators 67. The actuators 67 may be hydraulic, electrical, and/or electromechanical. For  
25 example, the actuator(s) 67 may comprise a small downhole motor to compress or relax one or more spring loaded hydraulic pistons.

Other and further embodiments utilizing one or more aspects of the inventions described above can be devised without departing from the spirit of Applicant's invention. For example, while the roller cone support arm 17 has  
30 been shown to move with respect to the longitudinal axis 15 of the bit body 11, the blades 19 may move with respect to the longitudinal axis 15 of the bit body 11 in other embodiments. In other words, the roller cone support arm 17

- 10 -

and/or the blades 19 may slide with respect to the longitudinal axis 15 of the bit body 11. Thus, the roller cone cutting elements 25 and/or fixed cutting elements 31 may slide with respect to the other and/or the longitudinal axis 15 of the bit body 11. In some embodiments, only a portion of one or more blade(s) 19, or a select group of the cutters 25,31, may be moved to effectuate the change between primary and secondary cutting structures. The bit 10 may also include one or more locking lugs, or similar structure to prevent movement of the arms 17 and/or blades 19 with respect to the body 13. In this case, the bit 10 may include additional actuators 67 to engage/disengage the lugs. Alternatively, the actuators 67 may be configured to engage/disengage the lugs after/before moving the arms 17 and/or blades 19. In some embodiments, the roller cone cutting elements 25 and/or fixed cutting elements 31 may be placed in a neutral position, such as that shown in FIG. 1 and FIG. 2, as well as the primary and secondary positions shown in FIG. 3 and FIG. 4.

Additionally, rather than being embedded within the bit body 13, as shown, the sensor 61 and/or the processor 65 may be located elsewhere in the bottom hole assembly, drill string, and/or at the surface. Further, the various methods and embodiments of the present invention can be included in combination with each other to produce variations of the disclosed methods and embodiments. Discussion of singular elements can include plural elements and vice-versa.

The order of steps can occur in a variety of sequences unless otherwise specifically limited. The various steps described herein can be combined with other steps, interlineated with the stated steps, and/or split into multiple steps. Similarly, elements have been described functionally and can be embodied as separate components or can be combined into components having multiple functions.

The inventions have been described in the context of preferred and other embodiments and not every embodiment of the invention has been described. Obvious modifications and alterations to the described embodiments are available to those of ordinary skill in the art. The disclosed and undisclosed

- 11 -

embodiments are not intended to limit or restrict the scope or applicability of the invention conceived of by the Applicants, but rather, in conformity with the patent laws, Applicants intend to fully protect all such modifications and improvements that come within the scope or range of equivalent of the following claims.

**What is claimed is:**

1. An earth boring drill bit comprising:  
a bit body having a longitudinal axis along a path of the bit;  
a first plurality of cutters mounted to the body;  
a second plurality of cutters rotatably mounted to the body, wherein a longitudinal axial relationship between the first plurality of cutters and the second plurality of cutters is adjustable;  
a sensor providing an indication of a formation type being excavated by the bit; and  
a processor programmed to control the longitudinal axial relationship based on the indication.
2. The bit as set forth in claim 1, wherein the first plurality of cutters are mounted to the body in such a manner as to allow them to move along the longitudinal axis.
3. The bit as set forth in claim 1 or 2, wherein the second plurality of cutters are mounted to the body in such a manner as to allow them to move along the longitudinal axis.
4. The bit as set forth in any one of claims 1 to 3, wherein the longitudinal axial relationship may be adjusted to exchange the first plurality of cutters and the secondary plurality of cutters between a primary cutting position and a secondary cutting position.
5. The bit as set forth in any one of claims 1 to 4, wherein the processor is further programmed to cause the first plurality of cutters to shift parallel to the longitudinal axis based on the indication.
6. The bit as set forth in any one of claims 1 to 4, wherein the processor is further programmed to cause the second plurality of cutters to shift parallel to the longitudinal axis based on the indication.

7. The bit as set forth in any one of claims 1 to 3, wherein the processor is further programmed to adjust the longitudinal axial relationship to exchange the first plurality of cutters and the secondary plurality of cutters between a primary cutting position and a secondary cutting position based on the indication.

8. An earth boring drill bit assembly comprising:  
a bit body having a longitudinal axis along a path of the bit;  
a first plurality of cutters mounted to the body;  
a second plurality of cutters rotatably mounted to the body;  
a sensor providing an indication of a formation type adjacent the body;

and

a processor programmed to control a longitudinal axial relationship between the first plurality of cutters and the second plurality of cutters based on the indication.

9. The bit assembly as set forth in claim 8, wherein the processor is further programmed to trigger at least one actuator to cause the first plurality of cutters to shift parallel to the longitudinal axis based on the indication.

10. The bit assembly as set forth in claim 8, wherein the processor is further programmed to trigger at least one actuator to cause the second plurality of cutters to shift parallel to the longitudinal axis based on the indication.

11. The bit assembly as set forth in claim 8, wherein the processor is further programmed to trigger at least one actuator to adjust the longitudinal axial relationship to exchange the first plurality of cutters and the secondary plurality of cutters between a primary cutting position and a secondary cutting position based on the indication.

12. A method of drilling a borehole in an earth formation, the method comprising the steps of:

receiving an indication of a formation type adjacent a drill bit from a sensor located within the borehole; and

triggering an actuator to adjust a longitudinal axial relationship between a polycrystalline diamond compact (PDC) cutter and a roller cone cutter located on the bit in response to a processor programmed to analyze the indication.

13. The method as set forth in claim 12, wherein the triggering step comprises exchanging the PDC cutter and the roller cone cutter between a primary cutting position and a secondary cutting position.

14. The method as set forth in claim 12 or 13, wherein the triggering step comprises shifting the PDC cutter parallel to a longitudinal axis of the bit.

15. The method as set forth in claim 12 or 13, wherein the triggering step comprises shifting the roller cone cutter parallel to a longitudinal axis of the bit.

16. An earth boring drill bit assembly comprising:  
a bit body having a longitudinal axis along a path of the bit;  
at least one blade mounted to the body;  
a first plurality of cutters fixedly mounted to the blade;  
at least one leg mounted to the body;  
a second plurality of cutters rotatably mounted to the leg;  
a sensor providing an indication of a formation type adjacent the body;

and

a processor internal to the body and programmed to control a longitudinal axial relationship between the first plurality of cutters and the second plurality of cutters to exchange the first plurality of cutters and the secondary plurality of cutters between a primary cutting position and a secondary cutting position based on the indication.

17. The bit assembly as set forth in claim 16, further including at least one locking lug configured to prevent movement of the blade with respect to the

body and wherein the processor is further programmed to trigger a plurality of actuators to disengage the lugs and cause the first plurality of cutters to shift parallel to the longitudinal axis based on the indication.

18. The bit assembly as set forth in claim 16, further including at least one locking lug configured to prevent movement of the leg with respect to the body and wherein the processor is further programmed to trigger a plurality of actuators to disengage the lugs and cause the second plurality of cutters to shift parallel to the longitudinal axis based on the indication.

1/5

FIG. 1

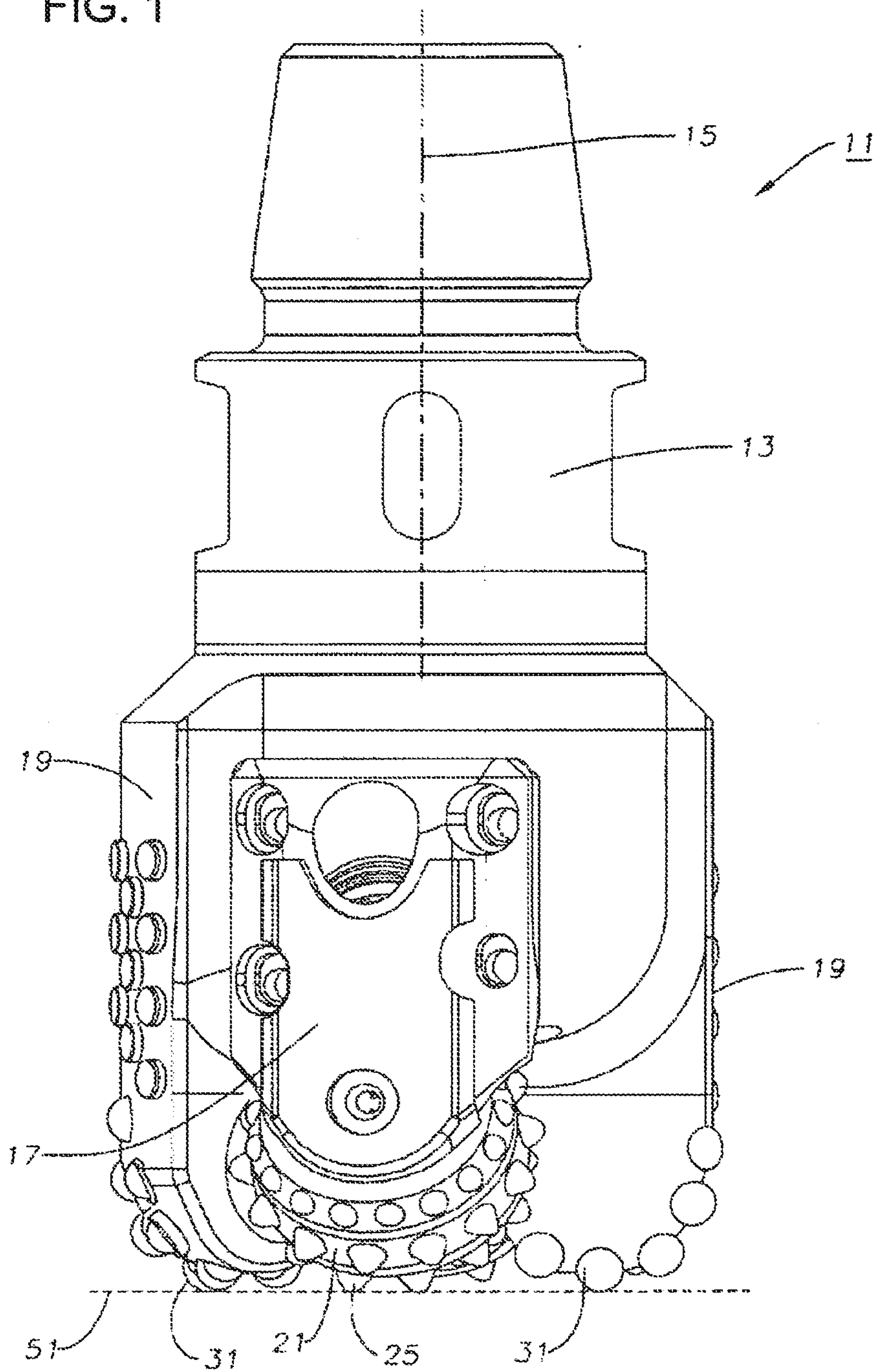

2/5

FIG. 2

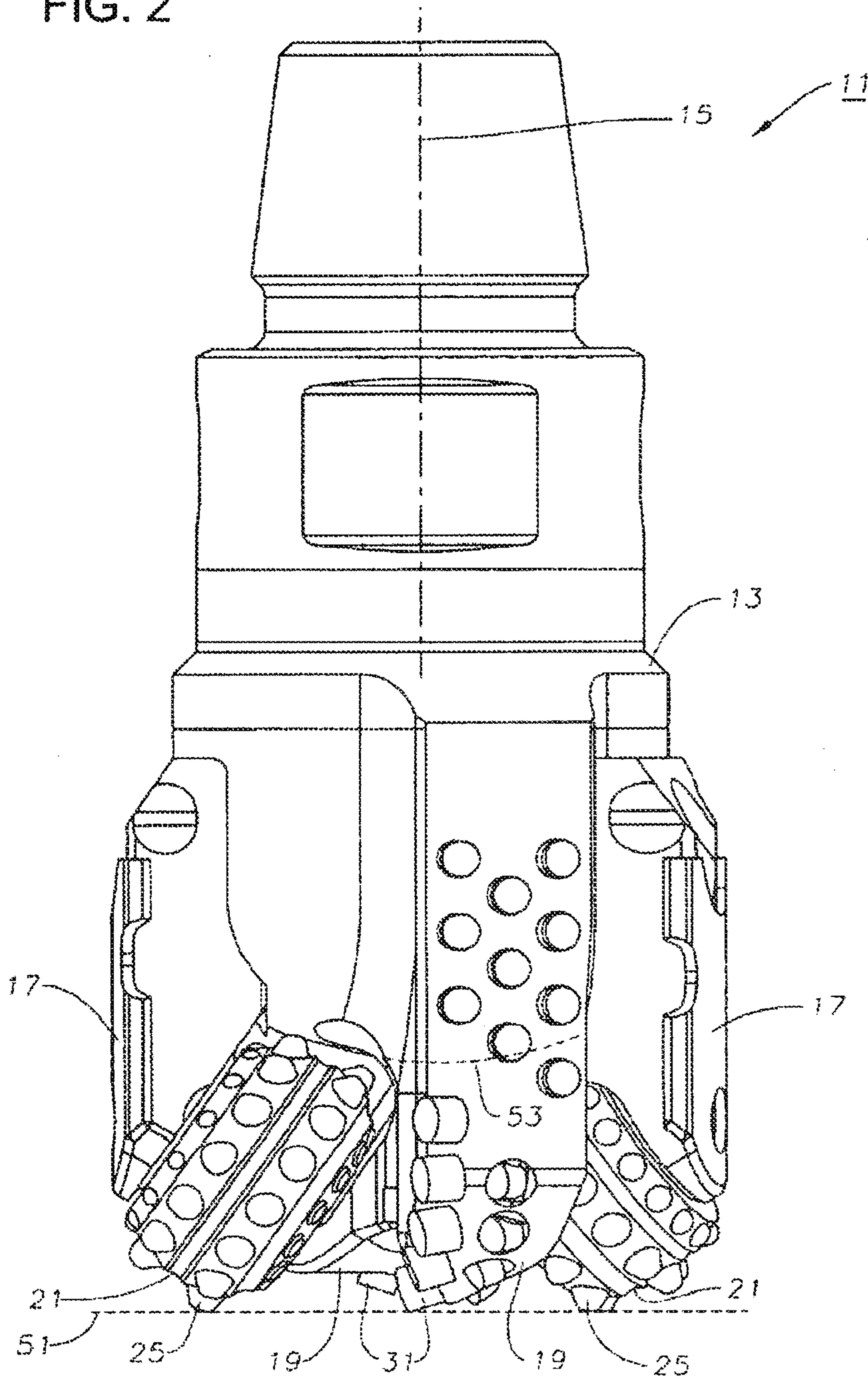

3/5

FIG. 3

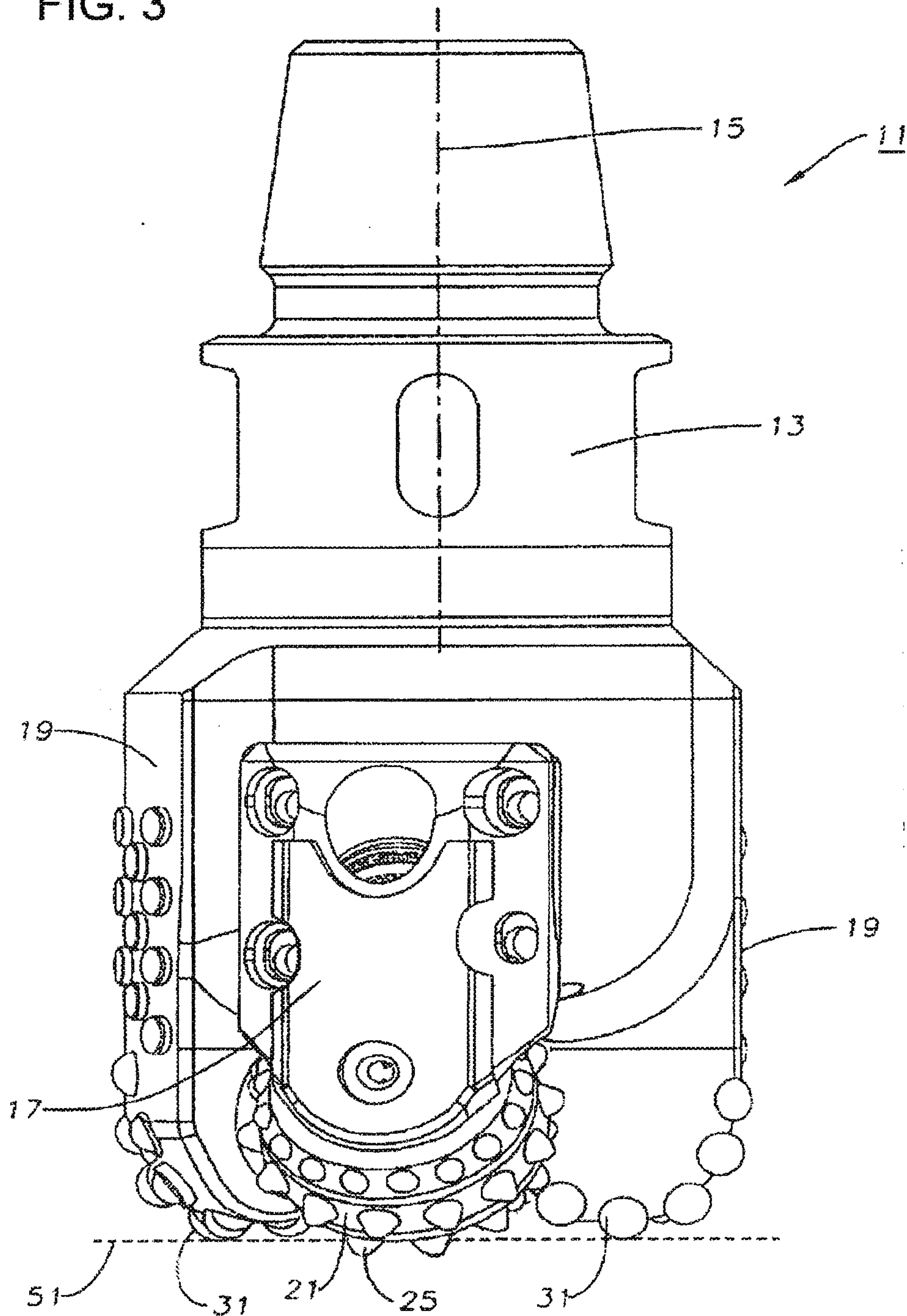

4/5

FIG. 4

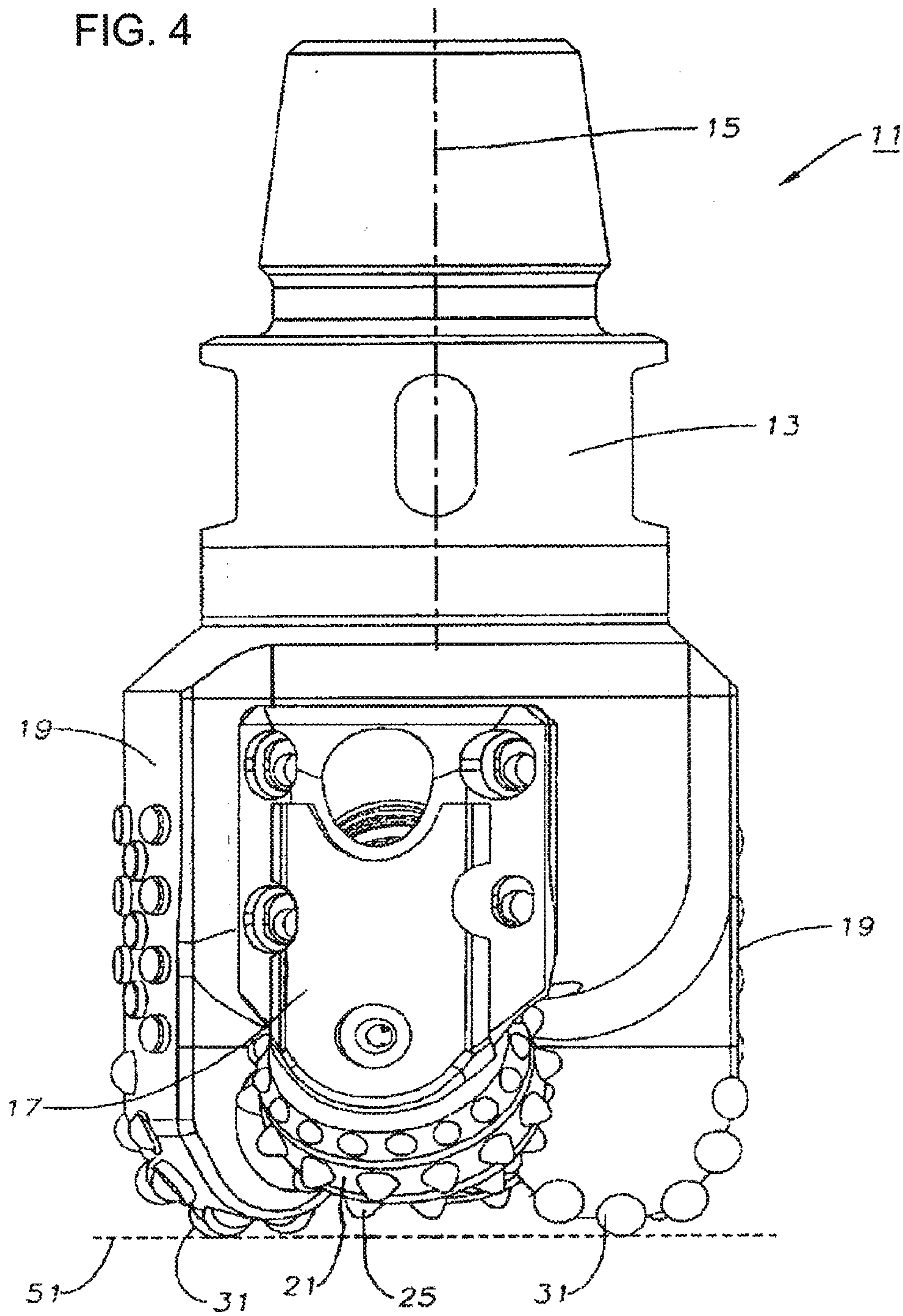

5/5

FIG. 5

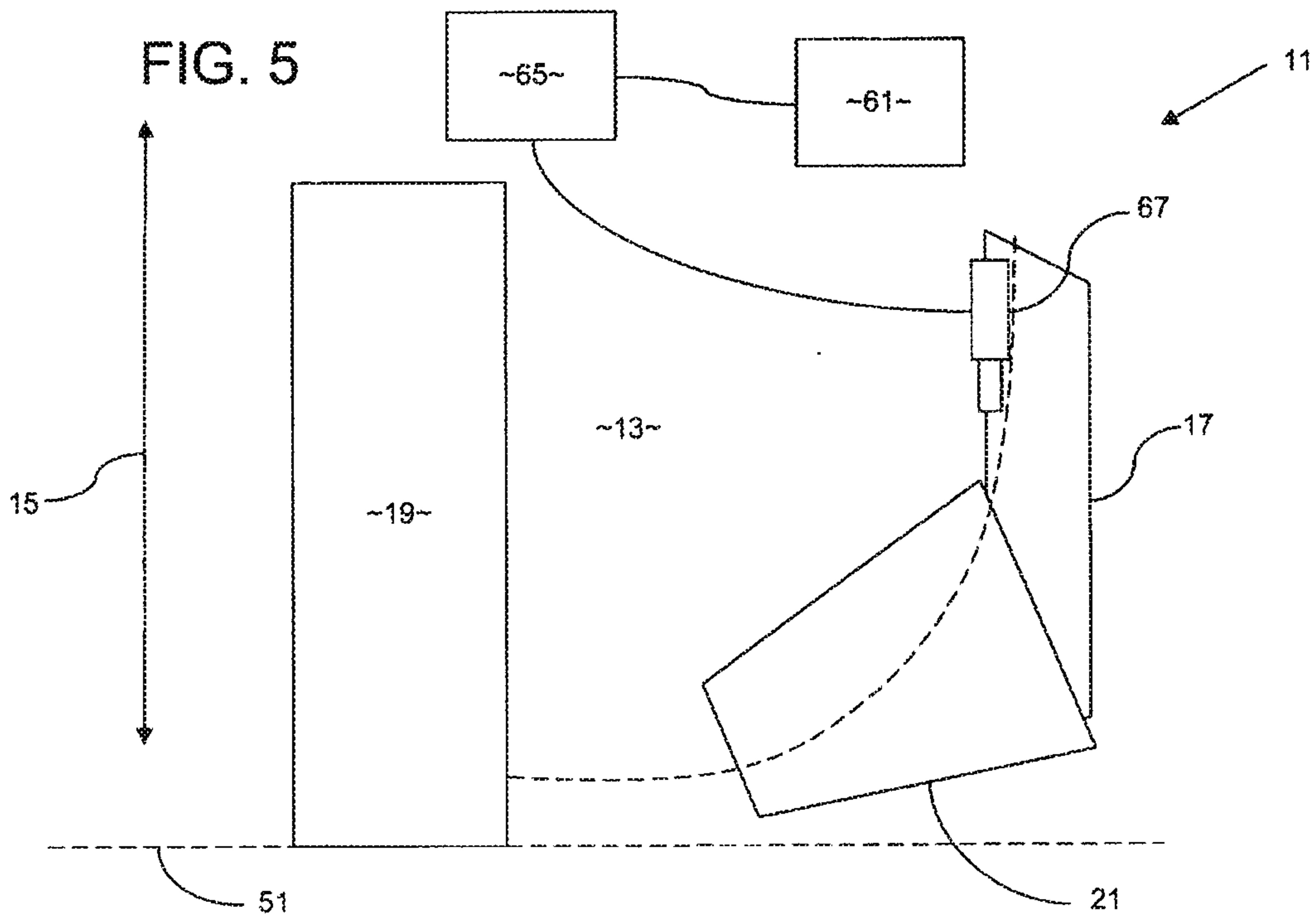

FIG. 6

