



(51) International Patent Classification:
H04L 5/00 (2006.01)

(21) International Application Number:
PCT/SE2016/051297

(22) International Filing Date:
20 December 2016 (20.12.2016)

(25) Filing Language: English

(26) Publication Language: English

(30) Priority Data:
62/435,125 16 December 2016 (16.12.2016) US

(71) Applicant: TELEFONAKTIEBOLAGET LM ERICSSON (PUBL) [SE/SE]; Torshamnsgatan 21-23, 164 83 Stockholm (SE).

(72) Inventors: WILLARS, Per; Stenvägen 6, SE-185 94 Vaxholm (SE). HEDBERG, Tomas; Frejgatan 45, SE-113 26 Stockholm (SE).

(74) Agent: SJÖBERG, Mats; Ericsson AB, Patent Unit Kista, RAN Implementation & Core (PU-KRIC), 164 80 Stockholm (SE).

(81) Designated States (unless otherwise indicated, for every kind of national protection available): AE, AG, AL, AM, AO, AT, AU, AZ, BA, BB, BG, BH, BN, BR, BW, BY, BZ, CA, CH, CL, CN, CO, CR, CU, CZ, DE, DJ, DK, DM, DO, DZ, EC, EE, EG, ES, FI, GB, GD, GE, GH, GM, GT, HN, HR, HU, ID, IL, IN, IR, IS, JP, KE, KG, KH, KN, KP, KR, KW, KZ, LA, LC, LK, LR, LS, LU, LY, MA, MD, ME, MG, MK, MN, MW, MX, MY, MZ, NA, NG, NI, NO, NZ, OM, PA, PE, PG, PH, PL, PT, QA, RO, RS, RU, RW, SA, SC,

(54) Title: ASSIGNING RADIO RESOURCES FOR COMMUNICATION BETWEEN A MULTI-OPERATOR RADIO NETWORK NODE AND A WIRELESS DEVICE

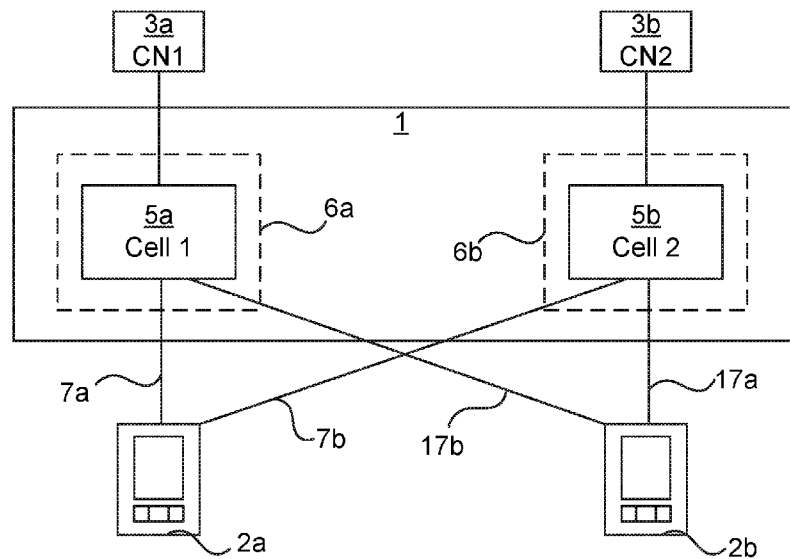

Fig. 5

(57) Abstract: It is presented a method for assigning radio resources for communication between a radio network node and a wireless device associated with a first cellular network, wherein the radio network node is configured to provide coverage using at least the first cellular network and a second cellular network. The method is performed in a radio resource allocation node and comprises the steps of: determining that radio resources on at least a first carrier, assigned to the first cellular network, are insufficient for data transmission between the radio network node and the wireless device; determining to use at least part of radio resources on a second carrier, originally assigned to the second cellular network, for a transmission associated with the first cellular network; and initiating transmission of a control signal to the wireless device over the first carrier, enabling the wireless device to use radio resources on the second carrier.



SD, SE, SG, SK, SL, SM, ST, SV, SY, TH, TJ, TM, TN, TR,
TT, TZ, UA, UG, US, UZ, VC, VN, ZA, ZM, ZW.

(84) Designated States (*unless otherwise indicated, for every kind of regional protection available*): ARIPO (BW, GH, GM, KE, LR, LS, MW, MZ, NA, RW, SD, SL, ST, SZ, TZ, UG, ZM, ZW), Eurasian (AM, AZ, BY, KG, KZ, RU, TJ, TM), European (AL, AT, BE, BG, CH, CY, CZ, DE, DK, EE, ES, FI, FR, GB, GR, HR, HU, IE, IS, IT, LT, LU, LV, MC, MK, MT, NL, NO, PL, PT, RO, RS, SE, SI, SK, SM, TR), OAPI (BF, BJ, CF, CG, CI, CM, GA, GN, GQ, GW, KM, ML, MR, NE, SN, TD, TG).

Published:

— *with international search report (Art. 21(3))*

ASSIGNING RADIO RESOURCES FOR COMMUNICATION BETWEEN A MULTI-OPERATOR
RADIO NETWORK NODE AND A WIRELESS DEVICE

TECHNICAL FIELD

The invention relates to a method, radio resource allocation nodes, a
5 computer program and a computer program product for assigning radio
resources for communication between a radio network node and a wireless
device.

BACKGROUND

Mobile broadband services are demanded in more and more locations, also
10 indoors. Enterprises are increasingly operating also out of the enterprise
premises, requiring the same connectivity and services inside and outside the
office.

There is a trend of Bring-your-own-device (BYOD), implying that enterprise
personnel (employees, consultants, etc.) bring their own devices, usually
15 associated with, or even locked to, a specific operator. The enterprise will
thus often need to support several operators. A trivial but expensive solution
to this is that all operators provide sufficient indoor coverage, which usually
implies separate indoor network equipment for each operator. However, this
option is not cost efficient, due to amount of radio equipment needed to cover
20 many frequency bands. From a cost perspective it is preferred to use a single
radio chain for all users, i.e. one spectrum band.

There is thus a cost reduction potential by designing shared networks
indoors. Current regulations and business logic implies that existing outdoor
networks typically remain separate. One possible scenario is that the shared
25 indoor system supports at least one cell (carrier) per outdoor network on a
frequency that is used by the outdoor network. This type of system allows for
sharing hardware for digital processing (given support in software), and for
radio processing (given that the instantaneous bandwidth covers spectrum
from multiple operators), while allowing separate configuration of cell
30 parameters for each operator (outdoor network). Enabling a cell on a

frequency band that is used in the outdoor network for a given operator also allows for simpler support of mobility from outdoor to indoor networks, as the mobile device is likely to already measure this frequency. This type of Radio Access Network (RAN) sharing is sometimes referred to as Multi-
5 Operator RAN (MORAN).

MORAN can also be applied in other indoor environments, e.g. in shopping centres and arenas and in outdoor environments, to increase coverage for a limited cost for operators.

SUMMARY

10 It is an object to improve throughput in MORAN implementations. Any increase in throughput is of great benefit for both operators and users.

According to a first aspect, it is presented a method for assigning radio resources for communication between a radio network node and a wireless device associated with a first cellular network, wherein the radio network
15 node is configured to provide coverage using at least the first cellular network and a second cellular network. The method is performed in a radio resource allocation node and comprises the steps of: determining that radio resources on at least a first carrier, assigned to the first cellular network, are insufficient for data transmission between the radio network node and the wireless
20 device; determining to use at least part of radio resources on a second carrier, originally assigned to the second cellular network, for a transmission associated with the first cellular network; and initiating transmission of a control signal to the wireless device over the first carrier, enabling the wireless device to use radio resources on the second carrier.

25 The step of transmitting a control signal may comprise transmitting a control signal to use carrier aggregation for the first carrier and the second carrier.

The step of transmitting a control signal may comprise transmitting a control signal to use dual connectivity for the first carrier and the second carrier.

The first cellular network and the second cellular network may be different Public Land Mobile Networks, PLMNs.

The step of determining to use at least part of radio resources on the second carrier may comprise determining to use only radio resources, for the
5 transmission associated with the first cellular network, which would be unused by the second cellular network.

The step of determining to use at least part of radio resources on the second carrier may comprise determining to use at least part of radio resources on
10 the second carrier for a transmission associated with the first cellular network only when data in a buffer for the wireless device is of a higher priority than data in a buffer for the second cellular network.

The method may further comprise the step of: triggering scheduling of data for the wireless device to be transmitted using the radio resources on the second carrier.

15 The method may further comprise the step of: recording the amount of data scheduled for the wireless device to be transmitted using the radio resources on the second carrier.

The method may be applied for downlink data.

The method may be applied for uplink data.

20 The step of determining to use at least part of radio resources on a second carrier may be performed only when a limit for resource usage for the first cellular network using the second carrier is not exceeded.

In one embodiment, the step of determining to use at least part of radio resources on a second carrier is only performed when a limit for resource
25 usage for cellular networks, other than the second cellular network, using the second carrier is not exceeded.

According to a second aspect, it is presented a radio resource allocation node for assigning radio resources for communication between a radio network node and a wireless device associated with a first cellular network, wherein the radio network node is configured to provide coverage using at least the
5 first cellular network and a second cellular network. The radio resource allocation node comprises: a processor; and a memory storing instructions that, when executed by the processor, cause the radio resource allocation node to: determine that radio resources on at least a first carrier, assigned to the first cellular network, are insufficient for data transmission between the
10 radio network node and the wireless device; determine to use at least part of radio resources on a second carrier, originally assigned to the second cellular network, for a transmission associated with the first cellular network; and initiate transmission of a control signal to the wireless device over the first carrier, enabling the wireless device to use radio resources on the second
15 carrier.

The instructions to transmit a control signal may comprise instructions that, when executed by the processor, cause the radio resource allocation node to transmit a control signal to use carrier aggregation for the first carrier and the second carrier.

20 The instructions to transmit a control signal may comprise instructions that, when executed by the processor, cause the radio resource allocation node to transmit a control signal to use dual connectivity for the first carrier and the second carrier.

The first cellular network and the second cellular network may be different
25 Public Land Mobile Networks, PLMNs.

The instructions to determine to use at least part of radio resources on the second carrier may comprise instructions that, when executed by the processor, cause the radio resource allocation node to determine to use only radio resources, for the transmission associated with the first cellular
30 network, which would be unused by the second cellular network.

The instructions to determine to use at least part of radio resources on the second carrier may comprise instructions that, when executed by the processor, cause the radio resource allocation node to determine to use at least part of radio resources on the second carrier for a transmission
5 associated with the first cellular network only when data in a buffer for the wireless device is of a higher priority than data in a buffer for the second cellular network.

The radio resource allocation node may further comprise instructions that, when executed by the processor, cause the radio resource allocation node to:
10 trigger scheduling of data for the wireless device to be transmitted using the radio resources on the second carrier.

The radio resource allocation node may further comprising instructions that, when executed by the processor, cause the radio resource allocation node to:
record the amount of data scheduled for the wireless device to be transmitted
15 using the radio resources on the second carrier.

The instructions may be applied for downlink data and/or the instructions may be applied for uplink data.

The radio resource allocation node may further comprise instructions that, when executed by the processor, cause the radio resource allocation node to
20 execute instructions to determine to use at least part of radio resources on a second carrier only when a limit for resource usage for the first cellular network using the second carrier is not exceeded.

The radio resource allocation node may further comprise instructions that, when executed by the processor, cause the radio resource allocation node to
25 execute the instructions to determine to use at least part of radio resources on a second carrier only when a limit for resource usage for cellular networks, other than the second cellular network, using the second carrier is not exceeded.

According to a third aspect, it is presented a radio resource allocation node comprising: means for determining that radio resources on at least a first carrier, assigned to a first cellular network, are insufficient for data transmission between a radio network node and the wireless device, wherein
5 the radio network node is configured to provide coverage using at least the first cellular network and a second cellular network; means for determining to use at least part of radio resources on a second carrier, originally assigned to the second cellular network, for a transmission associated with the first cellular network, thereby assigning radio resources for communication
10 between the radio network node and a wireless device associated with a first cellular network; and means for initiating transmission of a control signal to the wireless device over the first carrier, enabling the wireless device to use radio resources on the second carrier.

According to a fourth aspect, it is presented a radio network node comprising
15 the radio resource allocation node according to the second or third aspect.

According to a fifth aspect, it is presented a network node separate from any radio network node, the network node comprising the radio resource allocation node according to the second or third aspect.

According to a sixth aspect, it is presented a computer program for assigning
20 radio resources for communication between a radio network node and a wireless device associated with a first cellular network, wherein the radio network node is configured to provide coverage using at least the first cellular network and a second cellular network. The computer program comprises computer program code which, when run on a radio resource allocation node
25 causes the radio resource allocation node to: determine that radio resources on at least a first carrier, assigned to the first cellular network, are insufficient for data transmission between the radio network node and the wireless device; determine to use at least part of radio resources on a second carrier, originally assigned to the second cellular network, for a transmission
30 associated with the first cellular network; and initiate transmission of a

control signal to the wireless device over the first carrier, enabling the wireless device to use radio resources on the second carrier.

According to a seventh aspect, it is presented a computer program product comprising a computer program according to the sixth aspect and a computer
5 readable means on which the computer program is stored.

Generally, all terms used in the claims are to be interpreted according to their ordinary meaning in the technical field, unless explicitly defined otherwise herein. All references to "a/an/the element, apparatus, component, means,
step, etc." are to be interpreted openly as referring to at least one instance of
10 the element, apparatus, component, means, step, etc., unless explicitly stated otherwise. The steps of any method disclosed herein do not have to be performed in the exact order disclosed, unless explicitly stated.

BRIEF DESCRIPTION OF THE DRAWINGS

The invention is now described, by way of example, with reference to the
15 accompanying drawings, in which:

Fig 1 is a schematic diagram illustrating a cellular communication network where embodiments presented herein may be applied;

Figs 2A-B are schematic diagrams illustrating possible implementations of a radio resource allocation node;

20 Fig 3 is a schematic diagram illustrating frequency usage in the radio network node of Fig 1;

Fig 4 is a schematic diagram illustrating when separate radio network nodes are applied for different core networks;

25 Fig 5 is a schematic diagram illustrating when the common radio network node of Fig 1 is applied for different core networks;

Fig 6 is a schematic graph illustrating radio resource usage over time by two operators;

Figs 7A-7B are flow charts illustrating embodiments of method for assigning radio resources for communication between a radio network node and a wireless device associated with a first cellular network;

Fig 8 is a schematic diagram illustrating components of the radio resource allocation node of Figs 2A-B;

Fig 9 is a schematic diagram showing functional modules of the radio resource allocation node of Fig 8 according to one embodiment; and

Fig 10 shows one example of a computer program product comprising computer readable means.

10 DETAILED DESCRIPTION

The invention will now be described more fully hereinafter with reference to the accompanying drawings, in which certain embodiments of the invention are shown. This invention may, however, be embodied in many different forms and should not be construed as limited to the embodiments set forth herein; rather, these embodiments are provided by way of example so that this disclosure will be thorough and complete, and will fully convey the scope of the invention to those skilled in the art. Like numbers refer to like elements throughout the description.

Fig 1 is a schematic diagram illustrating a cellular communication network 9 where embodiments presented herein may be applied. The cellular communication network 9 comprises two separate core networks 3a-b and a radio network node 1, here in the form of a radio base station being an evolved Node B, also known as eNode B or eNB. The radio network node 1 could also be in the form of a Node B, BTS (Base Transceiver Station) and/or BSS (Base Station Subsystem), etc. It is to be noted that there may be more nodes in the network than what is shown in Fig 1. For instance, there may be intermediate nodes between the radio network node 1 and the core networks 3a-b, such as Radio Network Controllers or Base Station Controllers, or intermediate nodes for some 5G (5th Generation mobile networks) deployments.

Traditionally, each core network 3a-b is connected to its set of radio network nodes for providing radio connectivity for its wireless devices. Here, however, at least one radio network node 1 is used to provide radio connectivity for multiple core networks 3a-b. The reason for this can e.g. be to provide
5 enhanced access indoors, e.g. in a shopping centre or an arena. Another reason can be that the operators of the core networks share the cost of the radio network node 1.

Hence, the radio network node 1 is here a common radio network node which provides radio connectivity over a first wireless interface 4a-b to a first
10 wireless device 2a. Also, the radio network node 1 provides radio connectivity over a second wireless interface 14a-b to a second wireless device 2b.

The term wireless device is also known as mobile communication terminal, user equipment (UE), mobile terminal, user terminal, user agent, wireless terminal, machine-to-machine device etc., and can be, for example, what
15 today are commonly known as a mobile phone, smart phone or a tablet/laptop with wireless connectivity. The term wireless is here to be construed as having the ability to perform wireless communication. More specifically, the wireless device 2 can comprise a number of wires for internal and/or external purposes.

20 The first wireless device 2a and the first wireless interface 4a-b are associated with the first core network 3a. The second wireless device 2b and the second wireless interface 14a-b are associated with the second core network 3b. The first core network 3a is associated with a first PLMN (Public Land Mobile Network) operated by a first operator. The second core network 3b is
25 associated with a second PLMN operated by a second operator. It is to be noted that whenever the term PLMN is used herein, it can be replaced with network slice.

A network node 16 separate from the radio network node 1 is optionally provided. The network node 16 is in communication with the radio network
30 node 1 and can offload one or more tasks, such as resource allocation, from

the radio network node 1. The network node 16 can be provided locally by the radio network node 1 or remotely in a cloud installation.

The cellular communication network 9 may e.g. comply with any one or a combination of 5G NR (New Radio), LTE (Long Term Evolution), W-CDMA
5 (Wideband Code Division Multiplex), EDGE (Enhanced Data Rates for GSM (Global System for Mobile communication) Evolution), GPRS (General Packet Radio Service), CDMA2000 (Code Division Multiple Access 2000), or any other current or future wireless network, such as LTE-Advanced, as long as the principles described hereinafter are applicable.

10 Over the wireless interfaces, downlink (DL) communication 4a, 14a occurs from the radio network node 1 to the wireless devices 2a-b and uplink (UL) communication 4b, 14b occurs from the wireless devices 2a-b to the radio network node 1. The quality of the wireless radio interface to each wireless
15 device 2 can vary over time and depending on the position of the wireless device 2, due to effects such as fading, multipath propagation, interference, etc.

Being connected to two core networks 3a-b, the radio network node 1 is a radio network node 1 for multiple operators. In other words, the radio network node 1 implements a Multi-Operator RAN (MORAN). It is to be
20 noted that while Fig 1 shows two core networks 3a-b, the radio network node 1 can be connected to any suitable number of core networks and corresponding operators.

Figs 2A-B are schematic diagrams illustrating possible implementations of a radio resource allocation node 15.

25 In Fig 2A, the radio resource allocation node 15 is implemented as part of the radio network node 1 of Fig 1. In other words, the radio network node 1 is a host device of the radio resource allocation node 15.

In Fig 2B, the radio resource allocation node 15 is implemented as part of the network node 16 of Fig 1. In other words, the network node 16 is a host device of the radio resource allocation node 15.

Fig 3 is a schematic diagram illustrating frequency usage in the radio network node 1 of Fig 1, here provided for use with four operators. A first operator is assigned a first frequency band 11a. A second operator is assigned a second frequency band 11b. A third operator is assigned a third frequency band 11c. A fourth operator is assigned a fourth frequency band 11d. Compared to dedicated radio network nodes, the common radio network node may be limited in its frequency range. For instance, in this example, a frequency range 10 of the radio network node is not sufficient to cover all of the fourth frequency band. This may be deemed unfair treatment by the fourth operator, since the other frequency bands are completely covered by the MORAN, while only part of the fourth frequency band 11d is covered by the MORAN. Using embodiments presented herein, the fourth operator can utilise spare capacity allocated to other operators, thereby increasing fairness between operators in the MORAN.

Fig 4 is a schematic diagram illustrating when separate radio network nodes are applied for different core networks. Each wireless device 2a-b here connects using a primary cell and a secondary cell, e.g. using carrier aggregation (CA) and/or dual connectivity (DC).

The first core network 3a, of a first operator, here utilises a first radio network node 1a to provide radio connectivity for the first wireless device 2a. Specifically, the first radio network node 1a provides radio connectivity using its first cell 5a and second cell 5b. In this example, the cells 5a-b of the first radio network node 1a cooperate in the radio interface to the first wireless device. For instance, the two cells 5a-b can cooperate using carrier aggregation (CA) and/or dual connectivity (DC), as known in the art per se, to allow the network to communicate with the wireless device using a plurality of frequency bands. Here, the first cell 5a acts as a primary cell 7a for the first

wireless device 2a and the second cell 5b acts as a secondary cell 7b for the first wireless device 2a.

The second core network 3b, of a second operator, here utilises a second radio network node 1b to provide radio connectivity for the second wireless device 2b. Specifically, the second radio network node 1b provides radio connectivity using its first cell 5c and second cell 5d. In this example, the cells 5c-d of the second radio network node 1b cooperate in the radio interface to the second wireless device. For instance, the two cells 5c-d can cooperate using carrier aggregation (CA) and/or dual connectivity (DC) as known in the art per se. Here, the first cell 5c acts as a primary cell 17a for the second wireless device 2b and the second cell 5d acts as a secondary cell 17b for the second wireless device 2b.

The first radio network node 1a is responsible for proper coordination between its primary cell (i.e. the first cell 5a) and secondary cell (i.e. the second cell 5b) for communication with the first wireless device 2a. Analogously, the second radio network node 1b is responsible for proper coordination between its primary cell (i.e. the third cell 5c) and secondary cell (i.e. the fourth cell 5d) for communication with the second wireless device 2b.

Fig 5 is a schematic diagram illustrating when the common radio network node 1 of Fig 1 is applied for different core networks. Here, the common radio network node 1 is connected both to the first core network 3a and the second core network 3b. In this embodiment, the radio network node 1 can be operated by a neutral party in relation to the operators. The neutral party can be separate entity being responsible for MORAN deployments at various (e.g. indoor) locations. Alternatively, the operator of the radio network node 1 can be an office operator, a shopping centre owner, etc.

Within the radio network node 1, it is provided a first virtual radio network node 6a which is associated with the first core network 3a, and a second virtual radio network node 6b which is associated with the second core

network 3b. The first virtual radio network node 6a provides a first cell 5a and the second virtual radio network node 6b provides a second cell.

According to embodiments presented herein, radio resources of a cell of each operator can be utilised by another operator to improve overall utilisation
5 and throughput. For instance, the first cell 5a of the first operator is the primary cell 7a for the first wireless device 2a. However, the second cell 5b of the second operator can under some circumstances act as a secondary cell 7b for the first wireless device 2a. Analogously, the second cell 5b of the second operator is the primary cell 17a for the second wireless device 2a. However,
10 the first cell 5b of the first operator can under some circumstances act as a secondary cell 17b for the second wireless device 2b.

For the first wireless device 2a, the radio network node 1 is responsible for proper coordination between its primary cell 7a (i.e. the first cell 5a) and secondary cell 7b (i.e. the second cell 5b). Analogously, for the second
15 wireless device 2b, the radio network node 1 is responsible for proper coordination between its primary cell 17a (i.e. the second cell 5b) and secondary cell 17b (i.e. the first cell 5a).

This works especially well when radio resource utilisation is not completely used up by the two operators, as shown in more detail in Fig 6 and explained
20 below.

This cross assignment of resources works well since when the wireless device receives secondary cell data from a cell which is a primary cell for another operator, the wireless device disregards the primary cell signals of the other operator. Such primary cell signals can include PLMN identifier and/or
25 neighbouring cells list. The wireless device only obtains such information from its own primary cell. It is to be noted that only secondary cells are provided using radio resources normally allocated to other operators.

Fig 6 is a schematic graph illustrating radio resource usage over time by two operators. From a frequency perspective, there is a first frequency band 11a

which is primarily assigned to the first operator 20 and a second frequency band 11b which is assigned to the second operator 21.

At time T₁, there is no traffic for the second operator 21, hence, all radio resources can be assigned to the first operator 20. At time T₂, the second
5 operator 21 needs some radio resources, but the remaining radio resources in the second frequency band 11b can be utilised by the first operator 20. At time T₃, the radio resource requirements for the second operator 21 increases to eventually fill up all the resources of the second frequency band 11b. At time T₄, the first operator releases resources due to a decreasing buffer
10 (decreasing traffic demand), whereby the second operator 21 can now be allocated radio resources in the first frequency band 11a.

Fig 6 thus illustrates how demand for radio resources vary over time. By allocating radio resources in frequency bands primarily assigned for one operator also to another operator, the average throughput of both operators
15 can be increased.

Figs 7A-7B are flow charts illustrating embodiments of method for assigning radio resources for communication between a radio network node and a wireless device associated with a first cellular network. In accordance with what is described above, the radio network node is configured to provide
20 coverage using at least the first cellular network and a second cellular network. The method is performed in a radio resource allocation node and can be applied for downlink data and/or uplink data. As described above, the radio resource allocation node can be implemented in a radio network node 1 or a network node 16 separate from the radio network node 15. First, the
25 method of Fig 7A will be described.

In a *determine insufficient resources* step 40, the resource allocation node determines that radio resources on at least a first carrier, assigned to the first cellular network, are insufficient for data transmission between the radio network node and the wireless device. This determination can be based on a
30 data buffer.

In a *determine to use 2nd network* step 42, the resource allocation node determines to use at least part of radio resources on a second carrier, originally assigned to the second cellular network, for a transmission associated with the first cellular network. The radio resources on the second
5 carrier can e.g. be used as a secondary cell for the device.

The first cellular network and the second cellular network can be different Public Land Mobile Networks, PLMNs.

Optionally, this comprises determining to use only radio resources, for the transmission associated with the first cellular network, which would be
10 unused by the second cellular network. In other words, this embodiment prevents an operator's radio resources, when needed for the operator's own traffic, from being allocated to another operator.

Optionally, this comprises determining to use at least part of radio resources on the second carrier for a transmission associated with the first cellular
15 network only when data in a buffer for the wireless device is of a higher priority than data in a buffer for the second cellular network. In other words, this embodiment allows non-critical traffic of an operator's radio resources to be pre-empted by another operator's critical traffic. Non-critical traffic can e.g. be best effort traffic such as for web browsing, while critical traffic can
20 e.g. Guaranteed BitRate (GBR) services such as for a voice call. The determination of priority can be based on QCI (Quality of Service (QoS) Class Identifier). However, QCIs may differ across operators, in which case there can be a mapping of QCIs to allow cross operator comparisons.

Optionally, this step is only performed when a limit for resource usage for the
25 first cellular network using the second carrier is not exceeded. In other words, there can be limits configured for cross utilisation of radio resources for each pair of resources.

Optionally, this step is only performed when a limit for resource usage for cellular networks, other than the second cellular network, using the second
30 carrier is not exceeded. In other words, there can be limits configured for

cross utilisation of radio resources for each operator and all other operators as a group.

In a *transmit control signal to use 2nd network* step 44, transmission of a control signal to the wireless device over the first carrier is initiated. The
5 control signal enables the wireless device to use radio resources on the second carrier, e.g. as a secondary cell.

Optionally, this step comprises transmitting a control signal to use carrier aggregation for the first carrier and the second carrier.

Optionally, this step comprises transmitting a control signal to use dual
10 connectivity for the first carrier and the second carrier. The control signal can include information such as cell identifier, frequency, etc.

Embodiments of methods shown in Fig 7B will now be described. Only steps that are new or modified compared to what is described above with reference to Fig 7A, will be described here.

15 In a *trigger scheduling* step 46, scheduling of data for the wireless device to be transmitted using the radio resources on the second carrier is triggered. The scheduling can occur where traffic in the same spectrum is optimized differently. For instance, traffic for the first operator can be optimized differently than traffic for the second operator, even though all this traffic is
20 scheduled on the same carrier.

In a *record scheduled data amount* step 48, the amount of data scheduled for the wireless device to be transmitted using the radio resources on the second carrier is recorded. In this way, cross operator utilisation is recorded and can be analysed statistically. This allows an analysis to see how much of a first
25 operator's resources are utilised by a second operator and vice versa.

Using embodiments of the methods described, radio resources of a cell of each operator can be utilised by another operator to improve overall utilisation and throughput. Since utilisation of radio resources is rarely full, this provides a higher peak throughput for all operators.

Also, compared to shared cells for operators (MOCN, Multi-Operator Core Network) as described in 3GPP TS23.251, mobility parameters can be managed separately for the cell(s) of each operator. Furthermore, using the embodiments presented herein, the operators do not need to coordinate
5 common parameters, e.g. TAC (Tracking Area Code) values. In other words, this solution provides a much simpler implementation compared to MOCN. Moreover, when MORAN is deployed indoors, the indoor MORAN system uses frequency bands that are already in operation in the respective operator's outdoor network, which facilitates easier support for mobility
10 between outdoor and indoor network coverage.

Fig 8 is a schematic diagram illustrating components of the radio resource allocation node of Figs 2A-B. A processor 60 is provided using any combination of one or more of a suitable central processing unit (CPU), multiprocessor, microcontroller, digital signal processor (DSP), application
15 specific integrated circuit etc., capable of executing software instructions 67 stored in a memory 64, which can thus be a computer program product. The processor 60 can be configured to execute the method described with reference to Figs 7A-B above.

The memory 64 can be any combination of read and write memory (RAM)
20 and read only memory (ROM). The memory 64 also comprises persistent storage, which, for example, can be any single one or combination of magnetic memory, optical memory, solid state memory or even remotely mounted memory.

A data memory 66 is also provided for reading and/or storing data during
25 execution of software instructions in the processor 60. The data memory 66 can be any combination of read and write memory (RAM) and read only memory (ROM).

The radio resource allocation node further comprises an I/O interface 62 for communicating with other external entities.

Other components of the radio resource allocation node are omitted in order not to obscure the concepts presented herein.

It is to be noted that one or more of the components of Fig 8 may be shared with a hosting device, such as the radio network node 1 of Fig 2A or the
5 network node 16 of Fig 2B.

Fig 9 is a schematic diagram showing functional modules of the radio resource allocation node 15 of Fig 8 according to one embodiment. The modules are implemented using software instructions such as a computer program executing in the radio resource allocation node 15. Alternatively or
10 additionally, the modules are implemented using hardware, such as any one or more of an ASIC (Application Specific Integrated Circuit), an FPGA (Field Programmable Gate Array), or discrete logical circuits. The modules correspond to the steps in the methods illustrated in Figs 7A and 7B.

A determiner 70 corresponds to steps 40 and 42. A transmitter 72
15 corresponds to step 44. A scheduling trigger 74 corresponds to step 46. A recorder 76 corresponds to step 48.

Fig 10 shows one example of a computer program product comprising computer readable means. On this computer readable means a computer program 91 can be stored, which computer program can cause a processor to
20 execute a method according to embodiments described herein. In this example, the computer program product is an optical disc, such as a CD (compact disc) or a DVD (digital versatile disc) or a Blu-Ray disc. As explained above, the computer program product could also be embodied in a memory of a device, such as the computer program product 64 of Fig 8.

25 While the computer program 91 is here schematically shown as a track on the depicted optical disk, the computer program can be stored in any way which is suitable for the computer program product, such as a removable solid state memory, e.g. a Universal Serial Bus (USB) drive.

The invention has mainly been described above with reference to a few
30 embodiments. However, as is readily appreciated by a person skilled in the

art, other embodiments than the ones disclosed above are equally possible within the scope of the invention, as defined by the appended patent claims.

CLAIMS

1. A method for assigning radio resources for communication between a radio network node and a wireless device associated with a first cellular network, wherein the radio network node is configured to provide coverage
5 using at least the first cellular network and a second cellular network, the method being performed in a radio resource allocation node and comprising the steps of:
 - determining (40) that radio resources on at least a first carrier, assigned to the first cellular network, are insufficient for data transmission between
10 the radio network node and the wireless device;
 - determining (42) to use at least part of radio resources on a second carrier, originally assigned to the second cellular network, for a transmission associated with the first cellular network; and
 - initiating (44) transmission of a control signal to the wireless device
15 over the first carrier, enabling the wireless device to use radio resources on the second carrier.
2. The method according to claim 1, wherein the step of transmitting (44) a control signal comprises transmitting a control signal to use carrier aggregation for the first carrier and the second carrier.
- 20 3. The method according to claim 1, wherein the step of transmitting (44) a control signal comprises transmitting a control signal to use dual connectivity for the first carrier and the second carrier.
4. The method according to any one of the preceding claims, wherein the first cellular network and the second cellular network are different Public
25 Land Mobile Networks, PLMNs.
5. The method according to any one of the preceding claims, wherein the step of determining (42) to use at least part of radio resources on the second carrier comprises determining to use only radio resources, for the transmission associated with the first cellular network, which would be
30 unused by the second cellular network.

6. The method according to any one of the preceding claims, wherein the step of determining (42) to use at least part of radio resources on the second carrier comprises determining to use at least part of radio resources on the second carrier for a transmission associated with the first cellular network
5 only when data in a buffer for the wireless device is of a higher priority than data in a buffer for the second cellular network.
7. The method according to any one of the preceding claims, further comprising the step of:
triggering (46) scheduling of data for the wireless device to be
10 transmitted using the radio resources on the second carrier.
8. The method according to claim 7, further comprising the step of:
recording (48) the amount of data scheduled for the wireless device to
be transmitted using the radio resources on the second carrier.
9. The method according to any one of the preceding claims, wherein the
15 method is applied for downlink data.
10. The method according to any one of the preceding claims, wherein the method is applied for uplink data.
11. The method according to any one of the preceding claims, wherein the step of determining (42) to use at least part of radio resources on a second
20 carrier is only performed when a limit for resource usage for the first cellular network using the second carrier is not exceeded.
12. The method according to any one of the preceding claims, wherein the step of determining (42) to use at least part of radio resources on a second carrier is only performed when a limit for resource usage for cellular
25 networks, other than the second cellular network, using the second carrier is not exceeded.
13. A radio resource allocation node (15) for assigning radio resources for communication between a radio network node and a wireless device associated with a first cellular network, wherein the radio network node is

configured to provide coverage using at least the first cellular network and a second cellular network, the radio resource allocation node comprising:

a processor (60); and

a memory (64) storing instructions (67) that, when executed by the
5 processor, cause the radio resource allocation node to:

determine that radio resources on at least a first carrier, assigned to the first cellular network, are insufficient for data transmission between the radio network node and the wireless device;

determine to use at least part of radio resources on a second carrier,
10 originally assigned to the second cellular network, for a transmission associated with the first cellular network; and

initiate transmission of a control signal to the wireless device over the first carrier, enabling the wireless device to use radio resources on the second carrier.

15 14. The radio resource allocation node (15) according to claim 13, wherein the instructions to transmit a control signal comprise instructions (67) that, when executed by the processor, cause the radio resource allocation node to transmit a control signal to use carrier aggregation for the first carrier and the second carrier.

20 15. The radio resource allocation node (15) according to claim 13, wherein the instructions to transmit a control signal comprise instructions (67) that, when executed by the processor, cause the radio resource allocation node to transmit a control signal to use dual connectivity for the first carrier and the second carrier.

25 16. The radio resource allocation node (15) according to any one of claims 13 to 15, wherein the first cellular network and the second cellular network are different Public Land Mobile Networks, PLMNs.

17. The radio resource allocation node (15) according to any one of claims
30 13 to 16, wherein the instructions to determine to use at least part of radio resources on the second carrier comprise instructions (67) that, when

executed by the processor, cause the radio resource allocation node to determine to use only radio resources, for the transmission associated with the first cellular network, which would be unused by the second cellular network.

5 18. The radio resource allocation node (15) according to any one of claims 13 to 17, wherein the instructions to determine to use at least part of radio resources on the second carrier comprise instructions (67) that, when executed by the processor, cause the radio resource allocation node to determine to use at least part of radio resources on the second carrier for a
10 transmission associated with the first cellular network only when data in a buffer for the wireless device is of a higher priority than data in a buffer for the second cellular network.

19. The radio resource allocation node (15) according to any one of claims 13 to 18, further comprising instructions (67) that, when executed by the
15 processor, cause the radio resource allocation node to:
trigger scheduling of data for the wireless device to be transmitted using the radio resources on the second carrier.

20. The radio resource allocation node (15) according to claim 19, further comprising instructions (67) that, when executed by the processor, cause the
20 radio resource allocation node to:
record the amount of data scheduled for the wireless device to be transmitted using the radio resources on the second carrier.

21. The radio resource allocation node (15) according to any one of claims 13 to 20, wherein the instructions are applied for downlink data.

25 22. The radio resource allocation node (15) according to any one of claims 13 to 21, wherein the instructions are applied for uplink data.

23. The radio resource allocation node (15) according to any one of claims 13 to 22, further comprising instructions (67) that, when executed by the processor, cause the radio resource allocation node to execute instructions to

determine to use at least part of radio resources on a second carrier only when a limit for resource usage for the first cellular network using the second carrier is not exceeded.

24. The radio resource allocation node (15) according to any one of claims
5 13 to 23, further comprising instructions (67) that, when executed by the processor, cause the radio resource allocation node to execute the instructions to determine to use at least part of radio resources on a second carrier only when a limit for resource usage for cellular networks, other than the second cellular network, using the second carrier is not exceeded.
- 10 25. A radio resource allocation node (15) comprising:
means for determining (40) that radio resources on at least a first carrier, assigned to a first cellular network, are insufficient for data transmission between a radio network node and the wireless device, wherein the radio network node is configured to provide coverage using at least the
15 first cellular network and a second cellular network;
means for determining (42) to use at least part of radio resources on a second carrier, originally assigned to the second cellular network, for a transmission associated with the first cellular network, thereby assigning radio resources for communication between the radio network node and a
20 wireless device associated with a first cellular network; and
means for initiating (44) transmission of a control signal to the wireless device over the first carrier, enabling the wireless device to use radio resources on the second carrier.
26. A radio network node (1) comprising the radio resource allocation node
25 (15) according to any one of claims 13 to 25.
27. A network node (16) separate from any radio network node (1), the network node (16) comprising the radio resource allocation node (15) according to any one of claims 13 to 25.
28. A computer program (67, 91) for assigning radio resources for
30 communication between a radio network node and a wireless device

- associated with a first cellular network, wherein the radio network node is configured to provide coverage using at least the first cellular network and a second cellular network, the computer program comprising computer program code which, when run on a radio resource allocation node (15)
- 5 causes the radio resource allocation node (15) to:
- determine that radio resources on at least a first carrier, assigned to the first cellular network, are insufficient for data transmission between the radio network node and the wireless device;
 - determine to use at least part of radio resources on a second carrier,
 - 10 originally assigned to the second cellular network, for a transmission associated with the first cellular network; and
 - initiate transmission of a control signal to the wireless device over the first carrier, enabling the wireless device to use radio resources on the second carrier.
- 15 29. A computer program product (64, 90) comprising a computer program according to claim 28 and a computer readable means on which the computer program is stored.

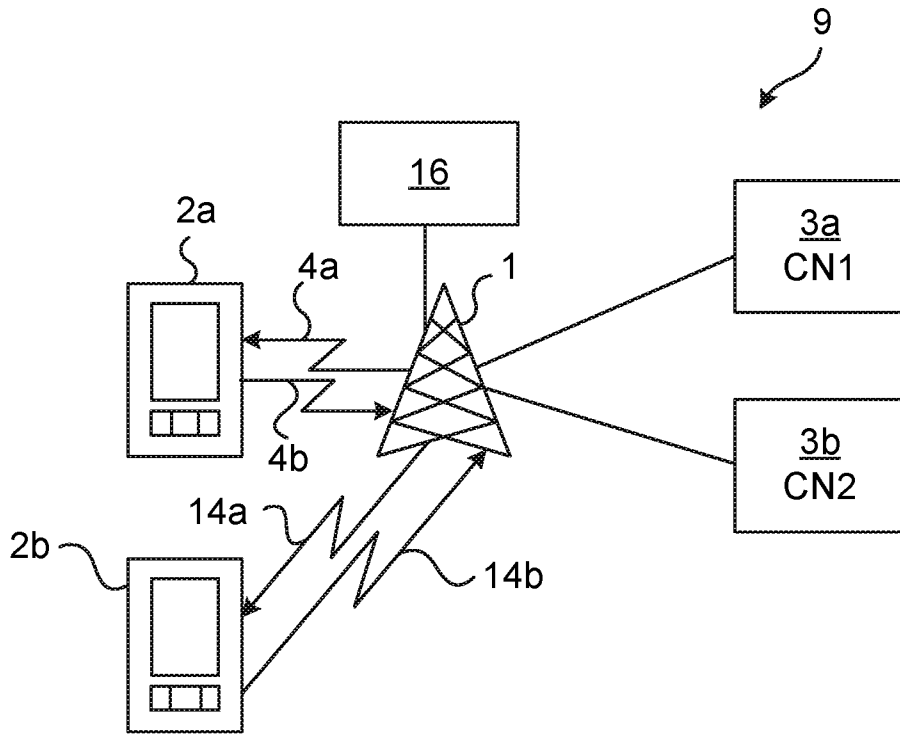

Fig. 1

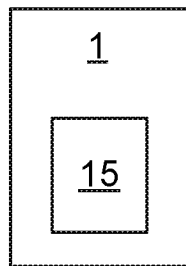

Fig. 2A

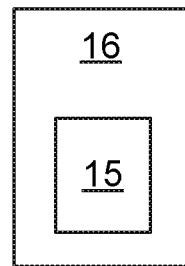

Fig. 2B

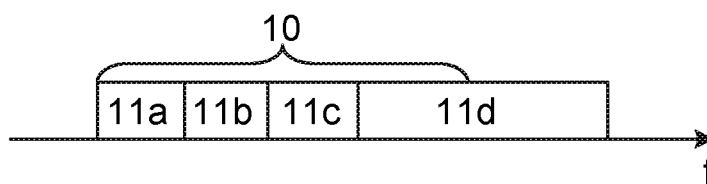

Fig. 3

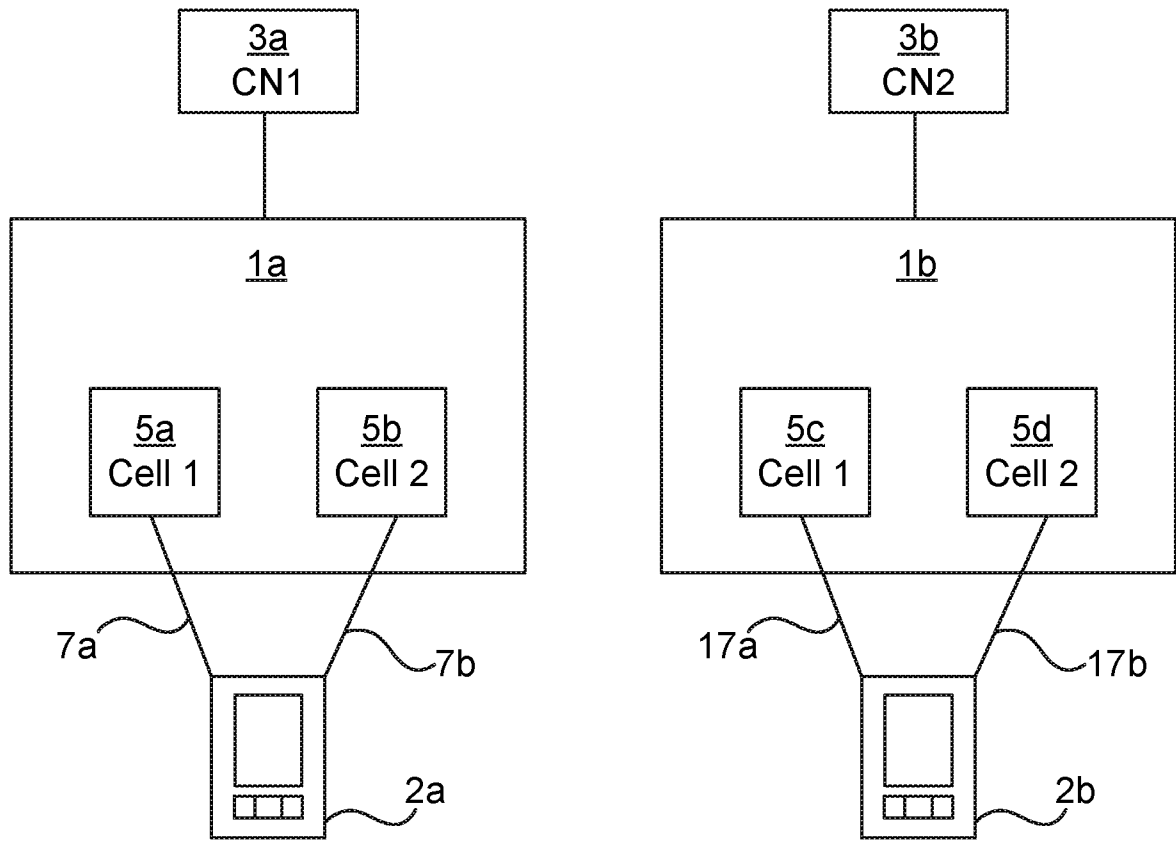

Fig. 4

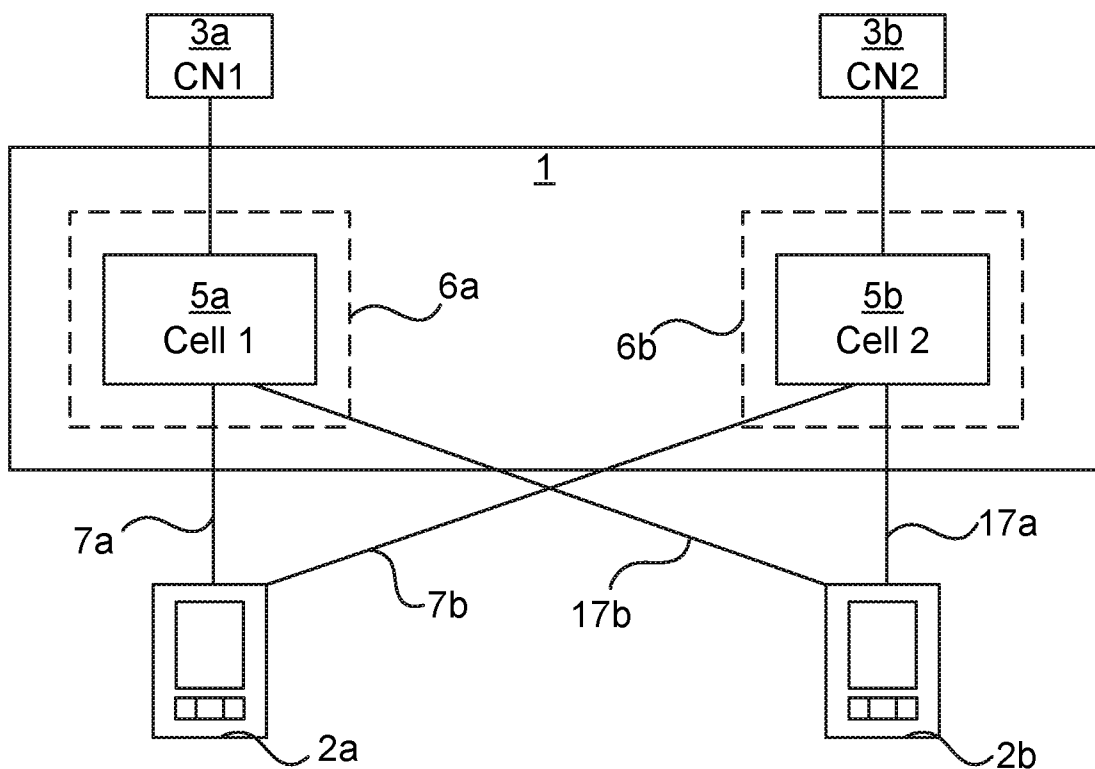

Fig. 5

3/4

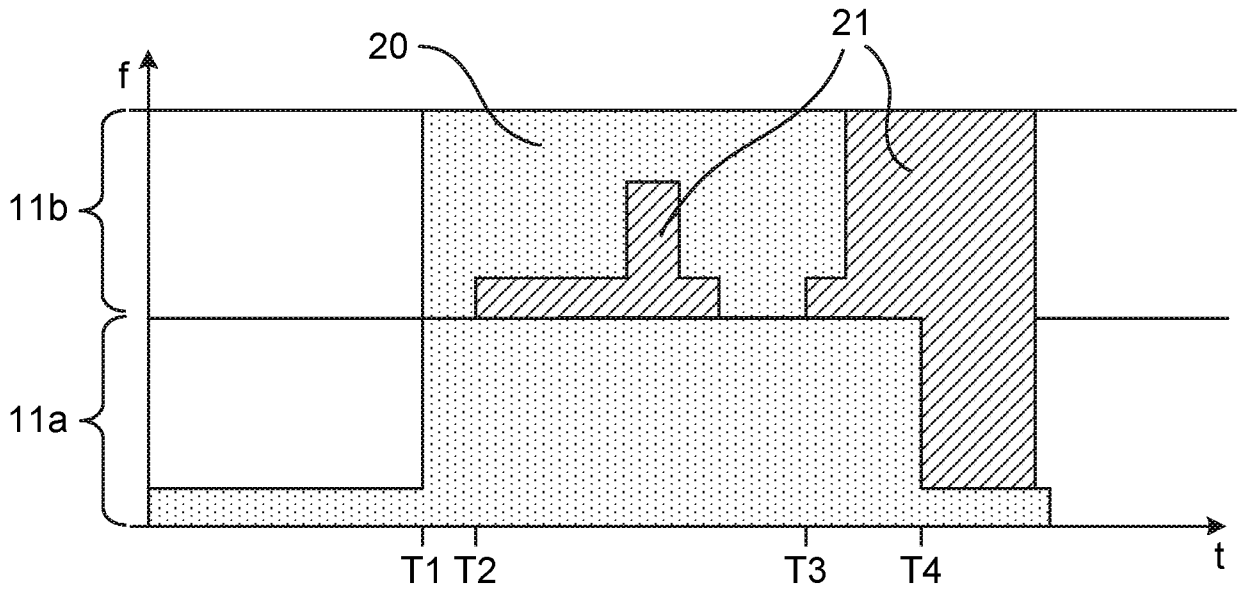

Fig. 6

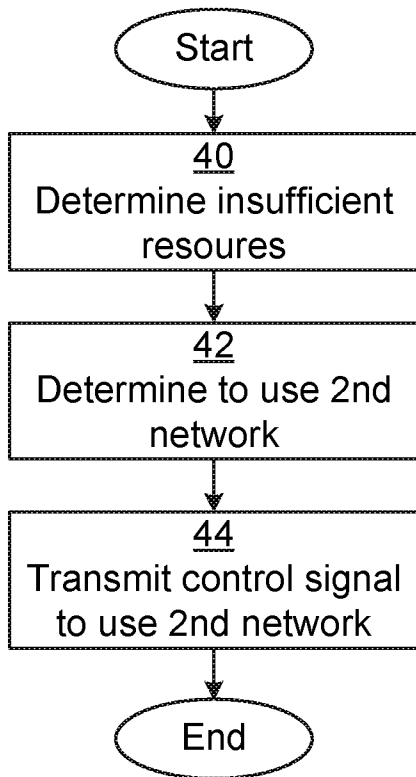

Fig. 7A

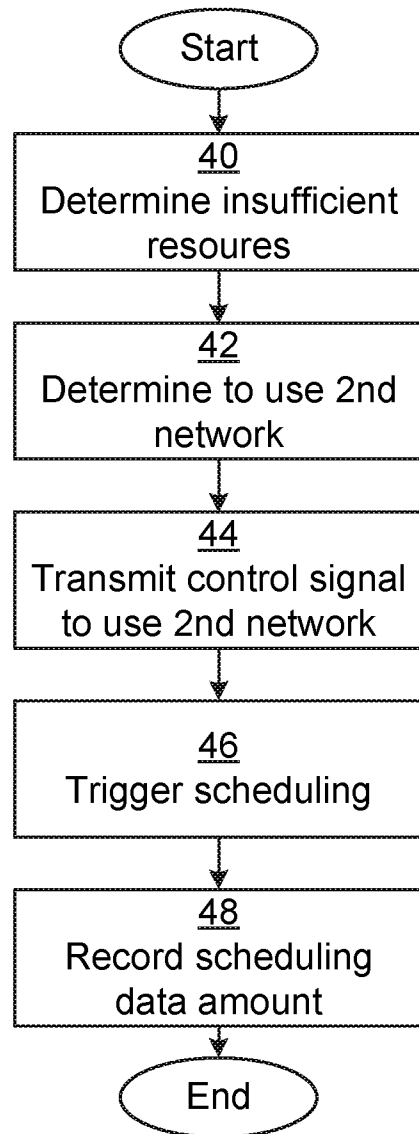

Fig. 7B

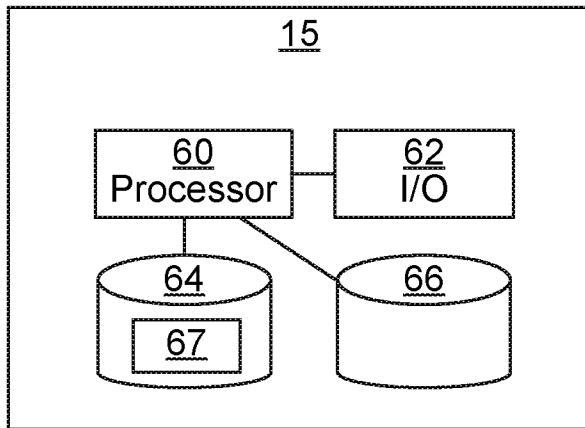

Fig. 8

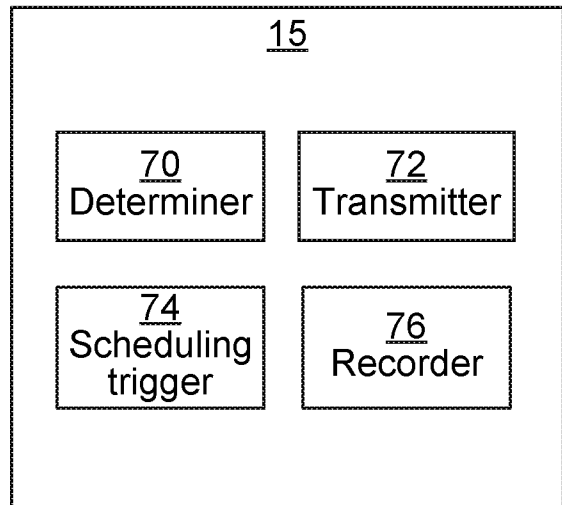

Fig. 9

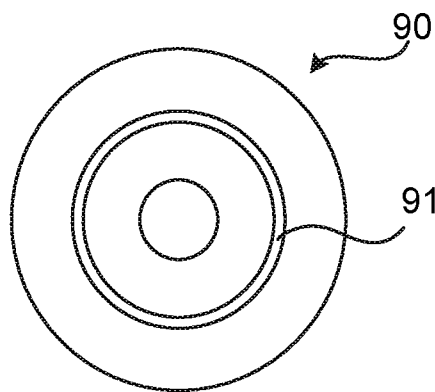

Fig. 10

INTERNATIONAL SEARCH REPORT

International application No
PCT/SE2016/051297

A. CLASSIFICATION OF SUBJECT MATTER
INV. H04L5/00
ADD.
According to International Patent Classification (IPC) or to both national classification and IPC

B. FIELDS SEARCHED
Minimum documentation searched (classification system followed by classification symbols)
H04L
Documentation searched other than minimum documentation to the extent that such documents are included in the fields searched

Electronic data base consulted during the international search (name of data base and, where practicable, search terms used)
EPO-Internal, WPI Data

C. DOCUMENTS CONSIDERED TO BE RELEVANT		
Category*	Citation of document, with indication, where appropriate, of the relevant passages	Relevant to claim No.
X	US 2014/023016 A1 (MILDH GUNNAR [SE] ET AL) 23 January 2014 (2014-01-23) paragraph [0003] - paragraph [0008]; figure 1 paragraph [0013] paragraph [0046] - paragraph [0069]; figures 2A, 2B, 3 paragraph [0099] - paragraph [0101] -----	1-29
A	EP 2 858 400 A1 (SONY CORP [JP]) 8 April 2015 (2015-04-08) paragraph [0034] - paragraph [0035]; figure 5 paragraph [0069] - paragraph [0090] ----- -/--	1-29

Further documents are listed in the continuation of Box C.

See patent family annex.

* Special categories of cited documents :

- "A" document defining the general state of the art which is not considered to be of particular relevance
- "E" earlier application or patent but published on or after the international filing date
- "L" document which may throw doubts on priority claim(s) or which is cited to establish the publication date of another citation or other special reason (as specified)
- "O" document referring to an oral disclosure, use, exhibition or other means
- "P" document published prior to the international filing date but later than the priority date claimed

"T" later document published after the international filing date or priority date and not in conflict with the application but cited to understand the principle or theory underlying the invention

"X" document of particular relevance; the claimed invention cannot be considered novel or cannot be considered to involve an inventive step when the document is taken alone

"Y" document of particular relevance; the claimed invention cannot be considered to involve an inventive step when the document is combined with one or more other such documents, such combination being obvious to a person skilled in the art

"&" document member of the same patent family

Date of the actual completion of the international search 8 August 2017	Date of mailing of the international search report 16/08/2017
Name and mailing address of the ISA/ European Patent Office, P.B. 5818 Patentlaan 2 NL - 2280 HV Rijswijk Tel. (+31-70) 340-2040, Fax: (+31-70) 340-3016	Authorized officer Devillers, Bertrand

INTERNATIONAL SEARCH REPORT

International application No
PCT/SE2016/051297

C(Continuation). DOCUMENTS CONSIDERED TO BE RELEVANT		
Category*	Citation of document, with indication, where appropriate, of the relevant passages	Relevant to claim No.
A	US 2014/106764 A1 (HUANG ANPENG [CN]) 17 April 2014 (2014-04-17) paragraph [0025] paragraph [0035] paragraph [0041] -----	1-29

INTERNATIONAL SEARCH REPORT

Information on patent family members

International application No PCT/SE2016/051297

Patent document cited in search report	Publication date	Patent family member(s)	Publication date	
US 2014023016	A1	23-01-2014	CN 103460772 A	18-12-2013
			EP 2698017 A1	19-02-2014
			US 2014023016 A1	23-01-2014
			WO 2012141628 A1	18-10-2012

EP 2858400	A1	08-04-2015	CN 104380779 A	25-02-2015
			EP 2858400 A1	08-04-2015
			JP 6065005 B2	25-01-2017
			JP WO2013183331 A1	28-01-2016
			RU 2014148135 A	20-06-2016
			US 2015119064 A1	30-04-2015
			WO 2013183331 A1	12-12-2013

US 2014106764	A1	17-04-2014	CN 104782211 A	15-07-2015
			US 2014106764 A1	17-04-2014
			US 2016192384 A1	30-06-2016
			WO 2014056187 A1	17-04-2014
