



(51) International Patent Classification:

G08G 1/16 (2006.01) A63K 3/00 (2006.01)
G08G 1/123 (2006.01)

(21) International Application Number:

PCT/NZ2019/050131

(22) International Filing Date:

07 October 2019 (07.10.2019)

(25) Filing Language:

English

(26) Publication Language:

English

(71) Applicant: **PRECISION TRIATHLON SYSTEMS LIMITED** [NZ/NZ]; 335 Estuary Road, South New Brighton, Christchurch, 8062 (NZ).

(72) Inventors: **CLYNE, Marcus Neary**; 53 Glovers Road, Halswell, Christchurch, 8025 (NZ). **ELVERY, James Colin**; 11 Skinner Road, Mount Wellington, Auckland, 1060

(NZ). **MCNEICE, Dylan Charles**; 335 Estuary Road, South New Brighton, Christchurch, 8062 (NZ).

(74) Agent: **ELLIS TERRY** et al.; PO Box 10932, The Terrace, Wellington, 6143 (NZ).

(81) Designated States (unless otherwise indicated, for every kind of national protection available): AE, AG, AL, AM, AO, AT, AU, AZ, BA, BB, BG, BH, BN, BR, BW, BY, BZ, CA, CH, CL, CN, CO, CR, CU, CZ, DE, DJ, DK, DM, DO, DZ, EC, EE, EG, ES, FI, GB, GD, GE, GH, GM, GT, HN, HR, HU, ID, IL, IN, IR, IS, JO, JP, KE, KG, KH, KN, KP, KR, KW, KZ, LA, LC, LK, LR, LS, LU, LY, MA, MD, ME, MG, MK, MN, MW, MX, MY, MZ, NA, NG, NI, NO, NZ, OM, PA, PE, PG, PH, PL, PT, QA, RO, RS, RU, RW, SA, SC, SD, SE, SG, SK, SL, SM, ST, SV, SY, TH, TJ, TM, TN, TR, TT, TZ, UA, UG, US, UZ, VC, VN, ZA, ZM, ZW.

(84) Designated States (unless otherwise indicated, for every kind of regional protection available): ARIPO (BW, GH,

(54) Title: A POSITION DETECTOR AND SYSTEM

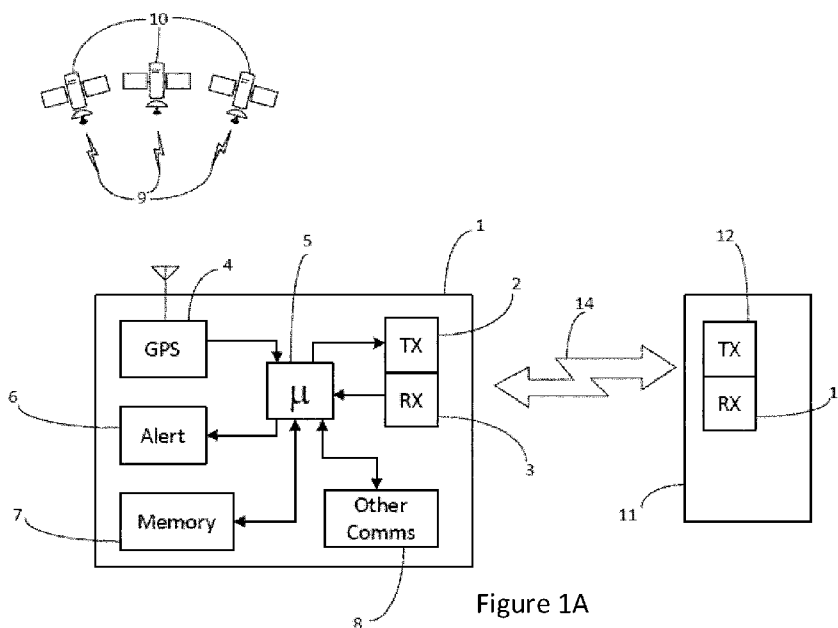

Figure 1A

(57) Abstract: A proximity monitor for monitoring a zone associated with a vehicle, such as during a race. In a race each vehicle may have a proximity monitor to enable monitoring of distances between proximate vehicles. Each proximity monitor may include an RF transmitter and an RF receiver to communicate with proximate monitors and use signal timing information to determine spacing between monitors. The monitor may use Ultra Wide Band (UWB) signals to determine spacing and other protocols for communication. The monitor may also detect whether another monitor passes. An alert signal may be generated if the spacing information, and optionally other information, satisfies an alert criterion. A system including such monitors may enable race officials to monitor infringement of rules and enforce penalties in real time on a race course.



GM, KE, LR, LS, MW, MZ, NA, RW, SD, SL, ST, SZ, TZ, UG, ZM, ZW), Eurasian (AM, AZ, BY, KG, KZ, RU, TJ, TM), European (AL, AT, BE, BG, CH, CY, CZ, DE, DK, EE, ES, FI, FR, GB, GR, HR, HU, IE, IS, IT, LT, LU, LV, MC, MK, MT, NL, NO, PL, PT, RO, RS, SE, SI, SK, SM, TR), OAPI (BF, BJ, CF, CG, CI, CM, GA, GN, GQ, GW, KM, ML, MR, NE, SN, TD, TG).

Published:

- *with international search report (Art. 21(3))*
- *in black and white; the international application as filed contained color or greyscale and is available for download from PATENTSCOPE*

A POSITION DETECTOR AND SYSTEM

TECHNICAL FIELD

5 The present subject matter relates generally to position monitoring and analysis and more specifically, although not exclusively, to drafting detection devices and penalty notification systems used in cycle races and triathlons.

BACKGROUND

10 In triathlon or similar multisport races, the cycling stage is treated as an individual time-trial. Riders are not permitted to gain an advantage by slipstreaming or drafting behind other riders. An exception to this is during overtaking; during such overtaking events, both riders will at some point be in a recognised 'drafting zone' in relation to the other rider. There is therefore a time and distance-based rule for overtaking, such that a rider must spend no more than a certain period of time within a certain distance behind another rider. Once overtaken, the now trailing rider must drop back to at least a minimum distance behind the lead rider in a rule specified time period.

15 If a rider violates such a rule, they accrue a time penalty which must be applied at some point during or after the race. Such rules are difficult to determine visually by race competitors and race referees and are difficult to enforce by race officials because they rely on the naked-eye judgements of competitors and referees in dynamic and often complex situations.

20 One solution is to use only GPS (or DGPS) to track competitors in real time and apply any penalties at the end of the cycling stage. GPS devices, even DGPS, have accuracy limitations and can lose the satellite signal if not in line of sight. Similarly, communicating GPS positions back to race officials, in order for a central system to detect drafting events, can be affected by loss of cell phone coverage.

2

Consequently, there may be large sections of the race course in which it is difficult to detect drafting accurately, or even impossible to determine if drafting has occurred at all. Using a cell phone for such applications is power-hungry and requires the addition of an external battery to enable tracking during long races.

5 Another solution uses a bicycle-mounted sonar-based distance sensor to determine the distance to a leading rider, to apply the appropriate rules to any sensed distance, and to warn or inform the trailing rider of any potential or actual violation of those rules. Sonar-based systems may detect unintended objects such as trees and road signs, causing “false positive” rule violation determinations. This
10 system will also struggle if multiple competitors or other moving objects are present within the range of the distance sensor. It is possible that rider #3 is drafting off two riders ahead (#1,#2), while rider #2 is also drafting off rider #1. Rider #3’s device needs to also be aware of rider #1’s position. If communicating with race officials with a cell phone, loss of signal may cause interruptions in
15 tracking or penalty processing.

None of these solutions are able to accurately determine the moment of pass and are subject to environmental conditions. Some solutions are also open to user tampering to defeat the system.

Some races include referees who are required to apply penalties and cautions and
20 may also be required to ensure that a competitor properly serves the penalty. These may require referees to quickly go to a penalty enforcement area after applying a penalty to ensure it is served, which can be inconvenient and may distract from the task of applying rules. They may also be open to circumvention or otherwise unreliable because a rider may go out of sight of a referee who had
25 been previously monitoring their behavior and may have issued a caution or penalty. Other referees may then be unaware of the rider’s past behavior and any cautions or penalties applied to them.

With systems such as these, and others of a similar nature, penalties must be applied at the end of a race stage when the riders are under the control of race officials. This deviates from normal competition and detracts from the spectator experience, in that the competitor order cannot be determined based solely on when they cross the finish line of the cycling stage. Applying penalties at the end of a race stage also detracts from the spectator experience because when a competitor is serving a drafting penalty there is often a lot of negative emotion and this can cause a negative spectacle. This can draw negative attention and detract from the positive image and nature of the event.

It is an object of the invention to provide a drafting detection, monitoring and penalty enforcement system or to at least provide the public with a useful choice.

SUMMARY

According to one example embodiment there is provided a proximity monitor for monitoring a zone associated with a vehicle, the proximity monitor comprising:

a first radiofrequency (RF) transmitter configured to communicate data with one or more proximate RF receivers of a proximate vehicle in the monitored zone;

a first RF receiver configured to acquire signal timing information from signals transmitted by one or more proximate RF transmitters of the proximate vehicle;

a processor configured to:

generate spacing information as to the spacing between the vehicle and the proximate vehicle;

generate an alert signal if the spacing information satisfies an alert criterion.

4

According to another exemplary embodiment there is provided a race communication system comprising:

a plurality of vehicles, each vehicle including a proximity monitor as set out in the preceding paragraph and a user indicator; and

5 one or more remote devices, each including an RF transceiver and a user interface;

wherein the proximity monitor of each vehicle is configured to:

transmit a signal to the remote device based on the spacing between the vehicle and a proximate vehicle;

10 and wherein the remote device is configured to:

receive the signal from the vehicle using the RF transceiver,

present information based on the spacing between the vehicle and the proximate vehicle to a user via the user interface;

receive an input from the user via the user interface;

15 generate a penalty signal based on the input from the user; and

wherein the penalty signal indicates that a penalty is to be applied to the proximate vehicle or a user thereof.

According to another example embodiment there is provided a proximity monitor comprising:

20 a. a RF transmitter configured to periodically communicate data with proximate RF receivers;

b. a RF receiver configured to acquire signal timing information from signals transmitted by proximate RF transmitters to develop spacing information as to the spacing between proximate transmitter and

25 receiver pairs;

5

- c. a GPS receiver for obtaining GPS position information;
- d. a processor configured to:
 - i. receive the GPS position information and spacing information,
 - ii. provide this information to the transmitter to communicate with proximate receivers,
 - iii. receive GPS position information and spacing information received by the receiver from proximate transmitters; and
 - iv. develop an alert signal if position and spacing information satisfies an alert criterion.

5

10

According to another example embodiment there is provided a proximity monitor comprising:

- a. a RF transmitter configured to periodically communicate with proximate receivers;
- b. a RF receiver configured to acquire signal timing information from signals transmitted by proximate transmitters to develop spacing information as to the spacing between proximate transmitter and receiver pairs;
- c. a processor configured to:
 - i. receive the spacing information, and
 - ii. develop an alert signal if the spacing information satisfies an alert criterion.

15

20

25

According to another example embodiment there is provided a proximity monitor having a front and rear to be aligned with the front and rear of a vehicle in use, comprising:

- a. a proximity detector for detecting the proximity of a second proximity monitor; and

6

- b. a processor for generating an alert signal when a proximity based criteria is satisfied; and
- c. a light driven when the alert signal is generated oriented to project light from the rear of the detector.

5

According to another example embodiment there is provided a passing detector comprising:

- a. a housing for mounting to a vehicle;
- b. a GPS receiver for obtaining GPS position information;
- 10 c. one or more lights generating lateral beams from the sides;
- d. one or more detector which detect the presence of light incident on the sides and generate a detection signal when specified characteristics of incident light are detected;
- e. a processor configured to:
 - 15 i. receive the GPS position information;
 - ii. receive the detection signal; and
 - iii. generate an alert signal.

According to another example embodiment there is provided a method of
20 determining the relative positions of a first and second vehicle, each having a RF transceiver and a GPS receiver comprising:

- a. determining the positions of vehicles based on GPS signals received by each GPS receiver;
- b. determining the spacing between vehicles based on the timing of
25 signals between transceivers; and
- c. developing an alert signal if position and spacing information satisfies an alert criterion.

According to another example embodiment there is provided a vehicle ordering method to be use between two race vehicles wherein each vehicle includes:

- a. front-mounted optical detector; and
- b. a rear-mounted and rear-facing optical transmitter,

5 whereby the rear-facing optical transmitter transmits a beam that identifies the race vehicle associated with the optical transmitter, and whereby the leading race vehicle transmits its identifying code to the detector of the trailing race vehicle, which the front-mounted detector detects when it is within a beam transmitted rearwardly by the rear-facing optical transmitter.

10

According to another example embodiment there is provided a race communication system comprising:

- a. a plurality of race vehicles, each including an RF transceiver;
- b. at least one fixed RF transceiver, located at a known location
15 around the race course;
- c. a central computing device; and
- d. a display device.

wherein each RF transceiver is configured to:

- a. communicate with other RF transceivers;
- 20 b. communicate location information between other RF transceivers;
- c. communicate with the central computing device either directly or via at least one other RF transceiver; and
- d. communicate penalty information between other RF transceivers.

25

According to another example embodiment there is provided a pass detecting system comprising:

- a. A plurality of position detectors, each including:
 - i. a housing for mounting to a vehicle;
 - ii. a GPS receiver for obtaining GPS position information;

8

iii. one or more light generating lateral beams from the sides;
and

iv. one or more detector which detect the presence of light incident on the sides and generates a detection signal when specified characteristics of incident light are detected; and

5

b. a central computer in communication with the position detectors which receives the GPS position information and detection signals from at least some of the position detectors and develops an alert signal if GPS position information and detection signal timing satisfies alert criteria.

10

According to another example embodiment there is provided an on-course penalty enforcement system, comprising:

- a. a race communication system;
- b. a penalty alerting device; and
- c. a plurality of penalty detection devices,

15

wherein the plurality of penalty detection devices are configured to detect a rule infraction and communicate via the race communication system to the penalty alerting device, and wherein the penalty alerting device displays a penalty alert to a user.

20

According to another example embodiment there is provided a method of enforcing an on-course penalty via a penalty alerting device comprising:

- a. detecting a rules infraction;
- b. indicating the rules infraction to a user by notification via the penalty alerting device;
- c. monitoring the position of the user;
- d. determining when the user has satisfied a penalty condition; and
- e. indicating the termination of the penalty to a user.

25

It is acknowledged that the terms “comprise”, “comprises” and “comprising” may, under varying jurisdictions, be attributed with either an exclusive or an inclusive meaning. For the purpose of this specification, and unless otherwise noted, these terms are intended to have an inclusive meaning – i.e., they will be taken to mean an inclusion of the listed components which the use directly references, and possibly also of other non-specified components or elements.

Reference to any document in this specification does not constitute an admission that it is prior art, validly combinable with other documents or that it forms part of the common general knowledge.

BRIEF DESCRIPTION OF THE DRAWINGS

The accompanying drawings which are incorporated in and constitute part of the specification, illustrate embodiments of the invention and, together with the general description of the invention given above, and the detailed description of embodiments given below, serve to explain the principles of the invention, in which:

Figure 1A is a block diagram of a distance measuring device;

Figure 1B is a block diagram of a further embodiment of a distance measuring device;

Figure 2 is a timing diagram showing the distance measurement process;

Figure 3A is a diagram showing a triangulated distance measurement;

Figure 3B is a block diagram of a distance measuring device that uses triangulation;

10

- 5 **Figure 4** is a diagram showing warning and drafting zones behind a cyclist;
- Figure 5** is a flow chart showing a drafting detection and penalty application process;
- Figure 6** is a diagram showing possible communication paths between devices;
- Figure 7** is a diagram showing how a rider may be informed of their proximity to another rider;
- Figure 8** is a block diagram of a further embodiment of a user device that detects passing events;
- 10 **Figure 9** is a diagram showing communication paths between passing event detectors;
- Figure 10A** is a diagram showing a penalty enforcement system;
- Figure 10B** is a diagram showing an alternative penalty enforcement system;
- Figure 11** is a flowchart showing the penalty enforcement process;
- 15 **Figure 12** is a diagram showing the use of communication beacons around a race course;
- Figure 13** is a block diagram of a further embodiment of a distance detection system; and
- Figure 14** is a diagram showing how the system of figure 13 may be used.
- 20 **Figure 15** is a block diagram of an example remote device that may be used by a referee.

DETAILED DESCRIPTION

Figure 1A illustrates a proximity monitor or distance measuring device according to an example embodiment. The proximity monitor 1 includes an RF transmitter 2, an RF receiver 3, a global positioning system (GPS) receiver 4, a microprocessor 5, an alert generator 6, memory 7 and communications module 8. The GPS receiver 4 receives GPS signals 9 from a plurality of GPS satellites 10 and sends the resulting position information to the microprocessor 5. The RF transmitter 2 and receiver 3 can exchange data 14 with a second proximity monitor 11, which includes its own transmitter 12 and receiver 13.

The proximity monitor 1 may be configured to monitor the presence of other devices in a monitored zone. The monitored zone is a zone around the proximity monitor or a vehicle bearing the proximity monitor. In some examples the monitored zone may be towards the rear of the vehicle. In some examples the monitored zone may be defined by a spacing/distance from the vehicle. In some examples, the monitored zone may be defined by an angle to the front-rear axis of the vehicle.

In one typical use the data sent by the proximity monitor 1 includes a unique identification code and the GPS position information determined by the GPS receiver 4. This data is sent to the second device 11 which then sends back its own set of data, and the timing information associated with this data exchange can be used to determine the spacing between the proximity monitor 1 and the other device 11.

If the combination of spacing information (space between monitor 1 and monitor 11 calculated from timing information contained in communications between monitors) and GPS position information satisfies some pre-determined condition or set of conditions, the microprocessor 5 activates the alert module 6. The microprocessor may also store this alert event in memory 7. The alert module can

12

then generate an alert signal. The alert signal can be used to activate an indicator coupled to the proximity monitor or forming part of the proximity monitor. This could, for example, be a visual or audible indicator to indicate an alert to another vehicle or user of another device.

5 Figure 1B illustrates a proximity monitor or distance measuring device according to a further example embodiment. The proximity monitor 15 is the same as the proximity monitor 1 except that it does not include the GPS module. However, a
10 GPS module 18 may be provided in a separate unit 17, which includes its own memory 19. Data 16 communicated to the second device 11 now does not include
15 GPS information. The microprocessor 5 now activates the alert module 6 if the spacing between the proximity monitor 15 and the second device 11 satisfies some pre-determined condition or set of conditions.

Any alert events can be stored in memory 7 along with time stamps, and compared at some later time with the GPS record stored in the GPS memory 19, which may
15 be for the purposes of determining event locations, discounting events based on their location, or some other event analysis.

In another example, information such as one or more of the spacing, GPS position and alert status is transmitted to a remote device (discussed later with respect to
20 Figures 12A and 12B). The proximity monitor could include a camera and the output of the camera could be transmitted to the remote device. The proximity monitor 1 or 15 can also receive information, such as alert information, from the remote device. This information can be transmitted between the proximity monitor 1 or 15 and the remote device using the RF transmitter and receiver 2, 3
25 or using one or more other communication modules 8. The information can be transmitted to the remote device continuously, periodically or upon satisfaction of a predetermined condition or set of conditions.

13

In this example, the remote device or a user thereof can assess the spacing and/or GPS position information. As a result of this assessment, the remote device can transmit a message to the proximity monitor 1 or 15. In response to this message, the proximity monitor 1 or 15 may activate its alert module 6. Alternatively or
5 additionally, the remote device can transmit a message to the second device 11 and in response to this message the second device 11 may activate an associated alert module.

The other communications modules 8 can include a Bluetooth module, a LoRa module, LoRaWAN module, a cellular communication module and/or a Sigfox
10 module. In one example, a Bluetooth module is provided for communicating with similar modules of other cycles via ad hoc mesh networking. The Bluetooth module may be used to transmit information such as GPS location information. In one example, a LoRa module is provided for longer range communications with the remote devices discussed above.

Figure 2 illustrates how the device separation may be determined from the data exchange timing. In the sequence on the left, TX1 and RX1 are the RF transmitter 2 and receiver 3 (respectively) of the proximity monitor 1 or 15; TX2 and RX2 are the corresponding elements of the second device 11. The second device has its own microprocessor 202. The microprocessor 5 starts an internal timer at time 21 and sends data to the transmitter 2 which broadcasts the data as a packet 20. This
20 is received by the receiver 13 at time 25 and passed to microprocessor 202. Once microprocessor 202 receives the data, it waits for a fixed time 26 and then issues its own data to its transmitter 12 at time 27. This return data packet 24 is received by the first receiver 3 at time 28 and is passed to the microprocessor 5, which then
25 stops its internal timer. The time recorded by this timer 29 is the sum of the known delay time 26 and twice the device separation divided by the speed of light. The delay time 26 is typically made sufficiently long to overcome any internal microprocessor delays or triggering times, so that the two transit delays may be

accurately recorded. Figure 2 illustrates this process with the leading edge of the data packets 20 and 24 defining the time measurement points, but it will be understood by those skilled in the art that any defined point in the data packets will serve equally well.

5 In one example, ultrawideband (UWB) technology is used for the RF transmitters and receivers and the associated antennas can be made omni-directional with separation resolution better than 0.5m. UWB signals can not only communicate data packets effectively over a variety of network configurations but can also, using the method illustrated in figure 2, effectively act as low-powered RADAR
10 systems. In some cases in which the UWB antennas are omni-directional, the relative orientation of the communicating devices may be unknown (i.e. the other device could be anywhere on the perimeter of a sphere having the known device spacing). The omni-directional UWB antennas can be replaced with directional versions, however in some situations such as cycle races omnidirectional antennas
15 may be preferable due to the increased flexibility with regard to antenna orientation.

Adding GPS position information to the UWB separation information may provide information as to the order, locations, speeds and/or directions of travel of riders (or of their monitoring devices, at least). When a number of monitoring devices
20 share their GPS and spacing information accuracy may be enhanced. Further, as rider order changes relatively slowly, and consistent with changes in spacing information, a historic record of both GPS positions and UWB separation information can be used to interpolate any gaps in the GPS data, such as would be obtained if riders pass through a short tunnel or forested area or nearby
25 mountains or tall buildings.

The GPS signal can often have a limited resolution, especially if few GPS satellites are in line of sight. It can therefore be advantageous to combine the proximity

15

monitors 1 or 15 with a second RF receiver, separated from the first receiver 3 by a fixed distance, and then use signal triangulation to determine both the separation and the bearing of the second device 11 (i.e. the direction to the second device). This arrangement is illustrated in Figures 3A and 3B, where receivers 3 and 30 are separated by a fixed distance 33. The microprocessor 5 associated with receivers 3 and 30 uses the timing information from the two receivers to determine the distances 31 and 32 between the receivers and the transmitter 12. Knowing the three distances, the angle 34 to the transmitter 12 can be determined using the formula 35. In this arrangement there are two transmitters 2 and 36 co-located at the receiver positions 3 and 30. An alternative embodiment uses two transmitters at known locations, with a single receiver and a microprocessor performing the triangulation calculations. The two receivers 3 and 30 and/or the two transmitters 2 and 36 can be spaced apart along the longitudinal axis of the cycle (i.e. the general direction of travel of the cycle) in use. This is to enable the proximity monitor 1 or 15 or a remote device to distinguish between transmitter locations in front of and behind the cycle bearing the proximity monitor 1 or 15.

In the example of Figures 3A and 3B, the two transmitters 2 and 36 and two receivers 3 and 30 are part of the same proximity monitor, however two separate proximity monitors 1 or 15 may be provided on each cycle with each proximity monitor 1 or 15 having a single RF transmitter and a single RF receiver.

Knowing the separation and direction information accurately is critical for identifying drafting events in a cycle race. Figure 4 illustrates the separations and directions that can be used to determine whether a drafting event is occurring and to generate the appropriate alert in the alert module 6. In one example the microprocessor 5 of the proximity monitors 1 or 15 determines whether a drafting event is occurring. In another example, the microprocessor 5 may determine a potential drafting event and, in response, transmit a message to a remote device, in which case the remote device or a user thereof may determine whether a

drafting event is occurring or has occurred. In another example, the proximity monitor 1 or 15 may continuously transmit information to the remote device without the need to make a determination of a drafting event or potential drafting event.

5 Immediately behind a cyclist 40 there is a rule based drafting zone 41, symmetrical on the longitudinal or front-rear axis 42 of the cycle and defined by a fixed radius 43 and segment angle 44. Any cyclist detected in this zone must be in the process of passing the lead cyclist 40 or falling back behind the lead cyclist 40, and so must not be in this zone for more than a certain length of time and must not enter the zone from behind then exit from behind. A pass manoeuvre, once initiated by entering the lead cyclist's drafting zone 41, must be completed by overtaking that lead rider within the specified length of time. There can also be a warning zone 45 behind the drafting zone 41 and this is defined by the same segment angle 44 and a second distance 46. The microprocessor may trigger the alert module 6 to generate a warning signal if a trailing rider enters this warning zone. The exact definition of a drafting zone is rule and condition dependent – gradient, speed, wind, and the course can all affect what criteria are applied to determine the relevant drafting and warning zone parameters. There may also be places in the race course where drafting detection and proximity monitoring is disabled, for example at the start of the race or in steep sections of the course where speeds fall below a certain level (causing following distances to decrease) and are so low that drafting gives trailing riders very little real or measurable advantage. Drafting may also be disabled for slow competitors falling below a given metric (speed, position etc.). GPS position information can be used to determine when to enable or disable drafting detection for these and other reasons (e.g. non-drafting zones). Such non-drafting zones may be mass pre-loaded to memory 7 of a monitoring device 1 of each competitor prior to a race. The batteries of monitoring units may also be mass charged, preferably via wireless charging. GPS information can also

be used to record the cyclist's speed and heading, and whether they have entered certain areas for specific purposes, such as waiting out any allotted penalty time.

Figure 5 shows a flow chart for identifying warning and drafting events according to one embodiment. The proximity monitor will (at step 50) first detect an approaching rider further away than the warning zone. The proximity monitor periodically checks whether the rider has entered the warning zone (at step 51) and, if so, trigger a warning event (step 52) which may take the form of a solid or flashing coloured or white light, an audible alarm or some other suitable indication. As long as the trailing rider stays in the warning zone, the warning event will continue. If it is determined that the trailing rider moves into the drafting zone (step 53) then a timer is started (step 54) and a drafting event is indicated (step 55). This may take the form of a flashing or non-flashing light or a constant tone or some other suitable indication. The proximity monitor periodically checks whether the trailing rider is still in the drafting zone (at step 56) and, if not, stops the timer and indicator (at step 57). If the trailing rider remains in the drafting zone for more than a specific length of time (at step 58) then a penalty may be applied to the trailing rider. If the trailing rider enters the drafting zone, and then drops backwards from the leading rider, this is recorded as a drafting event, and the time spent in the drafting zone for the duration of this drafting event is recorded and a penalty may be applied to the trailing rider. If the leading rider is passed by another rider and does not drop back in a suitable amount of time, this may be recorded as a drafting event and a penalty may be applied to the passed rider. This penalty is typically stored in the memory of the trailing rider's own proximity monitor but a record may also be kept in the memory of the proximity monitor of the leading rider, may be shared with all devices in range, out may be output to a referee presently within range or when they subsequently come within range.

In another embodiment of this invention, the proximity monitor of the rider being passed includes speed or acceleration sensors, and can determine if the lead rider significantly increases their speed when a trailing rider is in the lead rider's warning or drafting zones, as would be the case if the lead rider was trying to prevent the trailing rider from passing them. In a further embodiment of this invention, GPS
5 position data is exchanged at a variable rate between two proximity monitors. This exchange rate is typically increased during passing events.

This method illustrates also why it is advantageous to use either GPS or dual RF receivers (or transceivers) and triangulation to determine which rider is leading
10 and which rider is trailing. In certain circumstances, multiple warning or drafting events may be occurring simultaneously, as shown in Figure 6. Rider 61 is passing rider 60. Rider 65 is in the warning zone 66 of rider 62. Rider 62 is in the warning zone 63 of rider 60 and is also in the drafting zone 64 of rider 61. In situations like this, the UWB and/or Bluetooth transceivers of the various proximity monitors can
15 form an ad-hoc mesh network, record all of these events and save real-time position and event information from all the riders.

In another embodiment, the order of riders can be determined optically if each bicycle is fitted with a forward-mounted optical detector and a rear-facing optical emitter. The emitter emits a broad beam of light that substantially covers the
20 angle 44 of the warning and drafting zones, and repeatedly transmits a code which is unique to the bicycle. Any detector within range of a leading emitter will receive the code, so any associated processor will record which rider is ahead.

In another embodiment, some or all of steps 50, 51, 53, 54 and 56-59 can be performed by a remote device or a user thereof. For example, the method may
25 proceed as discussed above up to step 58. Once the time to pass is exceeded in step 58, a potential drafting event may be determined, which prompts a remote device or user thereof to determine whether a penalty should be applied. In a

preferred example, a human referee is provided with information that enables them to determine whether a penalty should be applied and to cause the penalty to be applied to the trailing rider.

In one embodiment one or both of, steps 52 and 54 are performed by a
5 corresponding proximity monitor associated with the trailing rider.

As mentioned in the method shown in Figure 5, it is advantageous to let the trailing rider know if they have entered the warning or drafting zones of a lead rider. It is difficult to judge precise distances and angles while riding. One example is shown in Figure 7, whereby a rear-facing visual indicator is included in the proximity
10 monitor of each rider. This can indicate to a trailing rider when they have entered another rider's drafting or warning zones. The trailing rider 73 has moved to within a certain distance 74 of the lead rider 72, causing the proximity monitor of the lead rider 71 to generate a warning and activate the visual indicator 70. As previously mentioned, this may take the form of a solid or flashing lamp if the
15 trailing rider is in the warning zone, or a continuous light if the trailing rider is in the drafting zone. Different colours or spatial or temporal patterns may also be used to indicate different alerts in other embodiments of the invention. For example, an accrued penalty may be indicated with a flashing red/blue light.

A visual signal may be presented at the front of the trailing rider's bicycle, so that
20 it may be seen if the rider is looking at, for example, their handlebar-mounted cycle computer. An audio signal may be presented to trailing rider. The audio signal may be presented by the trailing rider's cycle or proximity monitor or by the other rider's cycle or proximity monitor. In one example, a speaker is mounted to the forks of each cycle. In one example, a light is mounted at the front of each
25 cycle and configured to direct light upwards to the rider's face. In a preferred embodiment, the trailing rider is presented with an audio signal from a device on their own cycle and subsequently presented with a light signal directed upwards

at their face from a light source near the front of their cycle. Presenting the alert on a trailing rider's cycle may be advantageous in cases where applying a penalty takes a significant amount of time, for example when a referee makes a determination to apply a penalty. In these cases, the leading rider's cycle may not
5 be easily viewable by the time the penalty is applied.

In other embodiments of the invention, proximity and passing detection can be performed optically, as illustrated in Figure 8 which is the block diagram of a passing detector. The passing detector 80 includes a GPS unit 81, an alert module 82, a microprocessor 83, a memory module 84 and a means of data
10 communication 85. It also includes two optical modules 86, pointed in different directions. In each of these modules, a light source 87 (which could be a laser or LED) emits light in a fan 89 through a lens 88. Any light 90 received from a light source of a detector on another bike will be captured by lens 91 and focused onto a detector 92. The light fan 89 can be positioned, shaped and oriented so that it
15 is directed across a desired passing zone. The light from one or more of these modules may be modulated with a code that identifies the passing detector that these modules are attached to. Microprocessor 83 may use detection information from detector 92 to determine the moment of pass. A code modulated onto light 90 may also be used to identify the detector of the other bike. Such a unit provides
20 precise determination of a pass so that a lead rider may be informed that a pass has occurred and that they must drop back. Events and GPS positions can be stored in memory 84 and this data 93 can be communicated to another device 94 using the communication means 85 and 95.

Figure 9 illustrates how these passing detectors can be used in a race. The passing
25 detectors 96, 98, 99 and 100 are attached to bicycles (not shown) and are receiving GPS signals 9 from GPS satellites 10 so that each passing detector knows its own position. Detector 98 is in the process of passing detector 96. In this example all passing detectors are in communication 102 with a central computer 101. The

central computer 101 has received the position and passing event information from detector 96, has determined that detectors 96 and 98 are in a zone where drafting is not permitted, so has activated the event module of detector 96, causing it (in this illustration) to flash a warning light 97.

5 In another example, each cycle includes two RF transmitters 2, 36 and two RF receivers 3, 30 and performs triangulation to determine the angle to other cycles as discussed with respect to Figures 3A and 3B. The determined angle can be used to detect when one cycle has passed the other.

10 In other embodiments of the invention, if a rider accrues any penalties, a penalty enforcement system can then be used. In its simplest form, this penalty enforcement system includes a plurality of penalty detectors or one or more referees, a means of communicating any accrued penalties and some indicator that indicates a penalty to a rider. In other embodiments, the penalty enforcement system also includes monitoring the position of a penalty notification
15 device and/or a rider, and a means of informing the rider when their accrued penalty has been served.

The penalty may be served by a rider in several possible ways, including:

- Geo-fence (GPS based) – rider must go to a demarcated zone and stop until penalty period completed (light turns off or different light turns on).
- 20 • Beacon proximity – rider must go to a demarcated zone and remain in required proximity to a beacon until penalty observed.
- Any location – rider simply has to stop somewhere for a period of time. This is simple but less safe.
- End zone – rider must complete penalty time in a zone at the end of a race.
- 25 • Post race – all information and penalties applied based on post race calculations.

- Drop back – require rider to drop a prescribed distance behind another rider.
- Speed – the rider is required to keep their speed below a low maximum speed for a certain time.

5 Figure 10A illustrates the geo-fence embodiment of the penalty enforcement system. A course beacon 105 communicates with a rider's proximity monitor 107 and determines that the rider 107 has accrued a penalty. The beacon 105 then communicates 129 with an illuminated sign 108, which directs the rider to stop within a certain area 111. The sign 108 may also indicate that the rider 107 has
10 accrued a caution. The beacon also communicates to an audible alarm to attract the rider's attention. The rider's name and competitor ID can be displayed on the illuminated sign 108. This may have the effect of discouraging future drafting by the penalised rider or other riders.

The beacon 105 communicates 110 with the penalty monitor 112 and checks that
15 the rider is within the zone. Once a certain time has elapsed, the beacon 105 communicates 129 with the sign 108 (or communicates 109 with another screen or sign 114), which then informs the rider that they can leave the zone 113. In other embodiments of this invention, the beacon 105 may be included in the signs 108 and/or 114, or the signs 108 and/or 114 may communicate directly with the
20 proximity monitor 107, 112 without an additional beacon 105. The signs may also take the form of an indicator (Figure 13, 158) mounted in sight of the rider. In another embodiment of this invention, multiple penalties may be served all at once or in a series of penalty events; for this to happen, the penalty system can either erase all of a rider's accrued penalties, or erase some smaller subset of the
25 accrued penalties and force the rider to serve out the remaining penalties at some other time or place.

Figure 10B shows an alternative penalty enforcement system. In this case, a referee 170 receives communications from the proximity monitors 107. These may be long-range communications transmitted and received using long-range communication modules of the proximity monitors 107 and of a remote device 180 (detailed in Figure 15) carried by the referee 170. In one example, the communications are LoRa or LoRaWAN communications transmitted and received using LoRa or LoRaWAN modules. The proximity monitors may communicate 171 with each other to transfer information between each other but also to propagate information to the referee 170 or a beacon (shown as 105 in Figure 10A). The communication 171 between proximity units can be relatively short-range communication. In one example, the communications are via Bluetooth. In this example, the proximity monitor 107 of one rider may communicate to the referee's monitoring device 180 information regarding a proximate rider. If the referee 170 applies a penalty or a caution, a message can be transmitted to the proximate rider's monitor 107, the penalty monitor 112, and/or to the sign(s) 108, 114.

Figure 11 shows a flowchart of the penalty enforcement system according to one embodiment. A rider's proximity monitor communicates with the penalty enforcement system at 115. The penalty system checks whether a rule infraction has occurred (116); if not (117), no penalty is applied. If there has been a rule infraction, the rider is notified (118) of a penalty. The system may, if desired, check the rider location (119) and determine (120) whether the rider has entered a penalty waiting zone within an allotted time. If the rider has not entered the zone within this time, the penalty is retained (121). This check can also be whether the rider has moved past the penalty zone. If the rider has entered the zone, then a timer is started (122). The system then waits until the penalty time has elapsed (123) and then checks whether the rider is still within the penalty zone (124). If the rider has left early, then the penalty is not removed (125). Otherwise the penalty is cleared (126) and the rider is notified that they can proceed (127). In

another example, one or more of the steps of 116-127 is performed by, or with the input of, a user of a remote device. This user may be a race referee.

In cycle races, it is desirable to be able to communicate with all riders and to monitor things like their vital signs, their race position and speed and any penalties accrued or being served. For this all to happen, some sort of race communication system must be implemented. Figure 12 shows an embodiment of such a race communication system. The race course 134 starts and stops within a certain area 133, at which is commonly located a central processor 130 that may include a penalty enforcement or monitor module 131, and a display unit 132 that lets spectators see the race in progress. Spectators may follow riders' online viewing race metrics as well as penalty information for each rider. In other embodiments of the invention, the race course may have different starting and finishing locations.

In an embodiment of the invention, several beacons 136 are placed at fixed positions along the course 134. The central processor 130 can communicate 138 with these beacons and the beacons can communicate 139 between each other to form an ad-hoc mesh network, ring network or other suitable network architecture. Individual riders also have proximity monitors 135 and these monitors can communicate 140 with each other. The proximity monitors 135 can also communicate 139 with course beacons 136. The proximity monitors 135 can also communicate 141 with the central processor 130. These multiple communication pathways also form an ad-hoc network that can be dynamically configured or re-configured in use as its topology changes. Communication 139 between a single proximity monitor and two course beacons can be used to triangulate the position of the proximity monitor. In this and other similar embodiments, penalty information can be passed back to the penalty enforcement module 131 or retained and adjudicated within the proximity monitors 135 themselves. The beacons 136 may include illuminated signs 108

(Figures 10A, 10B). GPS position, biometric information, penalty data or other race history data can be stored within individual proximity monitors 135 for downloading into the central processor 130 at the end of the race. Centralised monitoring of GPS positions can also be used to check whether riders have gone off-course or have stopped unexpectedly, which may be due to a crash.

In one embodiment, one or more referees 170 may carry monitoring devices 180. The monitoring devices 180 may be configured to communicate 173 with the proximity monitors 135 directly or communicate 172 via beacons 136. The proximity monitors 135 may transmit information to the referees' monitoring devices 180 such that referee 170 can assess the data to determine, for example, whether a penalty should be applied or whether a penalty has been served. The monitoring devices 180 may also be configured to communicate with a wide area network 187 such as the internet. To this end, one or more radio transceivers 186 may be employed to communicate 188 with the monitoring devices 180. The transceivers 186 may be, for example, cellular communication towers. The transceivers 186 may in turn communicate 189 with the wide area network 187. In one example, each monitoring device 180 has installed thereon an application which can be used to monitor competitor's locations, separations and other data, assess potential offences and issue penalties or cautions, and/or view penalties or cautions applied by other referees. The application may be a client-side application in communication with a remote server over the network 187, such as a cloud-based server. When referees issue penalties and cautions, this information may be uploaded to the remote server over the network 187. The referees may also view the information uploaded by other referees over the network 187. This may allow referees to have complete knowledge of penalties and cautions applied to all competitors without the need to be in line of sight or proximity of them and may allow referees to concentrate on rule application rather than on-course policing of penalties. It also may allow referees who are outside the immediate vicinity of the riders who are committing offences to apply

penalties and cautions to those riders. This may improve competitor behavior and reduce rule circumvention.

In one embodiment, the proximity monitors 135 communicate with each other using Bluetooth communications. In one example, the proximity monitors
5 communicate 173 with beacons 136 and/or referees' monitoring devices 171 using LoRa or LoRaWAN communications. The various embodiments of the proximity monitors or passing detectors can also be augmented by the addition of other functions or modules. One such embodiment of an augmented proximity monitor is shown in figure 13. This proximity monitor 145 includes a
10 microprocessor 153, an RF transmitter 147, an RF receiver 148, a Bluetooth link 149, a memory module 152, a GPS receiver 146 and some other means of communications 156, which is required to access the microprocessor 153 or the memory module 152. This monitor is similar to that described in Figure 1.

The monitors can perform Bluetooth beaconing for advertising their presence to
15 other monitors within range. Based on Bluetooth beacon signals, the monitor may determine which other monitors to determine the distance to using the RF transmitter 147 and receiver 148. For example, the monitor could measure the distance to the nearest N other monitors or measure the distance to all other monitors within X metres. In one example, N is approximately 5. In one example,
20 X is approximately 30. This may reduce the bandwidth used by the RF transmitters and receivers for ranging. It may also reduce power consumption because Bluetooth beaconing is relatively low-power but long range. In order to determine which other monitors are nearest, a proximity monitor could use an indication of the signal strength of received messages. For example, the 4 or 5 monitors with
25 the highest received signal strengths could be selected for the distance measurement. Alternatively, all monitors with a signal strength above a threshold could be selected. In this scenario, the Bluetooth mesh can still be used to communicate information between the monitoring devices of the competitors.

This monitor also includes:

- a rear alert module and indicator 151;
- a rear-facing camera 185 for recording the image of any trailing riders;
- BLE 154 and ANT+ 155 modules for communicating with cycling computers, watches or other biometric or other telemetry devices;
- an accelerometer 157 which can detect any impacts or falls, permitting the processor 153 to communicate this sort of event to other riders or race officials; and
- a front-mounted module 150 that includes:
 - a user alert module 158 that gives the rider a visual or audible indication of proximity or penalty information; and
 - a front-mounted camera that can record images of any rider being approached or road situation.

The rear alert indicator 151 could produce a flashing light signal that flashes once a rider enters a drafting zone and that flashes with an intensity or colour pattern that helps a trailing rider keep track of time spent in the drafting zone. For example, it could flash with a different colour or intensity every 5 seconds.

In another embodiment of this invention, the accelerometer may be supplemented with a rider-activated push-button, used as a means to summon help or indicate that help is not required.

In another embodiment of this invention, the user alert module 158 of the front mounted module 150 includes a numeric display that can show the user:

- the decreasing distance in meters as the user gets closer to a leading rider;
- a timer that provides an indication of the time that the user has spent in the lead rider's drafting zone, which can take the form of an elapsed time or a time remaining to pass; and

- other race-dependent data.

Figure 14 illustrates how some of these additional features may be used in a race. A rider 160 has entered the drafting zone of a leading rider 161. The proximity monitor 164 of the leading rider 161 has determined that the trailing rider 160 is within the drafting zone and has activated its illuminated rear-facing indicator 165. It has also activated its rear-facing camera 163 to record an image of the trailing rider 160. The proximity monitor 164 also communicates the spacing information to the trailing rider's proximity monitor 168. This in turn activates an audio alarm 175 and/or an illuminated front-mounted indicator 166 in case the trailing rider 160 has not seen the rear-facing indicator 165. The proximity monitor 168 also activates the front-mounted camera 167, which records images of the leading rider 161, including their race ID number 162 and the surrounding road situation. These images may be accessed after the race as evidence should a protest be raised. The images may also be offered for sale to competitors or supporters during or after the race.

The referee may also issue a caution to the trailing rider 160. A caution may be issued due to the trailing rider being in the warning zone discussed with respect to Figure 4, i.e. could be equivalent to the warning discussed previously, or could be issued for other reasons.

Once issued, a penalty or caution can be transmitted to a penalty enforcement system. For example, the penalty or caution can be transmitted to the penalty monitor 112, and/or to the sign(s) 108, 114 of the penalty enforcement system of Figure 10A or 10B.

In one variation on this embodiment, the proximity monitor 164 of the leading rider determines a potential drafting event when the trailing rider 160 enters their drafting zone. The proximity monitor 164 then transmits spacing and/or GPS position information to a remote device to determine whether a penalty should

be applied. A referee operating the remote device determines to apply a penalty or a caution and the remote device transmits a message to the proximity monitor 168 of the trailing rider 160. The audio alarm 175 and/or illuminated front-mounted indicator 166 are then activated. Any of the data accumulated during the race, including positions, images, passing events or other telemetry data may be used to identify areas of the course associated with a high number of penalties, so that non-penalty zones may be applied to these areas in future races, or so that the course may be redesigned for future races.

While penalties and cautions have been discussed in the context of drafting, they may also be issued for other offences such as littering, outside assistance, and crossing a center line.

In a further embodiment of the invention, the rider may also wear a wrist-mounted tracking device 169 that includes a GPS receiver and an indicator, and that can communicate with a proximity monitor or proximity detector using an RF transceiver. This RF transceiver may be a Bluetooth transceiver or a UWB transceiver which will enable the tracking device to also communicate with other fixed or mobile UWB transceivers, so that if the race involves stages such as running or swimming, the wearer of the device 169 can still be tracked by a race communication system. The tracking device 169 may also incorporate a cellphone data transceiver so that it can communicate with the race communication system if the tracking device 169 is in range of a mobile phone network. The indicator on the tracking device 169 may be an audio indicator, a visual indicator, may generate some detectable haptic vibration or may provide any combination of these indication signals. The indicator can indicate information to a wearer such as cautions, penalty information, or any other race-based information.

Figure 15 shows one example of a monitoring device 180 that could be carried by a referee. The monitoring device 180 includes a communications modules 182

and 190 and a user interface 181. The communications module 182 may be configured for long range communications with proximity monitors, beacons, penalty systems and other devices. In one example, the communications module 182 is a LoRa or LoRaWAN module. The communications module 190 may be configured for communications with a wide area network. In one example, the communications module 190 is a cellular communications module. The user interface is configured to present information to, and receive inputs from, a user such as a referee. The user interface 181 could include one or more of a display screen, a speaker, or another visual display such as one or more indicator lights for presenting information to a user. The user interface 181 could include one or more of a touch screen, a mouse or trackpad, a keyboard or one or more other buttons for receiving user inputs. In one example, the monitoring device is a general-purpose computing device. In one example, the monitoring device is a tablet computer.

In conclusion, the advantages of these devices, systems and methods are:

- UWB is less subject to interference than GPS only or line of sight based solutions;
- UWB allows accurate non-line of sight measurement;
- A combination of GPS and UWB provides accurate spacing and ordering information to both competitors and referees;
- Communication between devices allows operation even if GPS or communication to the cloud is lost;
- UWB communication rather than a traditional 'sensor' ensures that what is detected is actually another competitor;
- The methods do not significantly deviate from how drafting is measured and enforced currently. In other words, riders receive, and are informed of, a penalty and they may serve it on the side of the course.

- A rear facing indicator light allows rider to keep eyes forward rather than continuously looking down to check their onboard indicator light.
- On course referees may not be required in some applications or may remain, supplemented by the automated system, to retain a human element in drafting determination.
- Images allow real-time or post-race scrutiny of the situation.
- UWB triangulation (or other pass detection) allows the determination of the moment in time at which a pass is completed, allowing accurate measurement of drafting events.
- Bluetooth mesh technology allows for a large ad-hoc network to form amongst nearby riders.
- LoRa or similar output to a referee means the referee can 'watch' and scrutinise riders from afar, which may reduce drafting or other rule infringements.

15

While the present invention has been illustrated by the description of the embodiments thereof, and while the embodiments have been described in detail, it is not the intention of the Applicant to restrict or in any way limit the scope of the appended claims to such detail. Additional advantages and modifications will readily appear to those skilled in the art. Therefore, the invention in its broader aspects is not limited to the specific details, representative apparatus and method, and illustrative examples shown and described. Accordingly, departures may be made from such details without departure from the spirit or scope of the Applicant's general inventive concept.

25

CLAIMS:

1. A proximity monitor for monitoring a zone associated with a vehicle, the proximity monitor comprising:
 - 5 a first radiofrequency (RF) transmitter configured to communicate data with one or more proximate RF receivers of a proximate vehicle in the monitored zone;
 - a first RF receiver configured to acquire signal timing information from signals transmitted by one or more proximate RF transmitters of the proximate vehicle;
 - 10 a processor configured to:
 - generate spacing information as to the spacing between the vehicle and the proximate vehicle;
 - generate an alert signal if the spacing information satisfies an alert criterion.
- 15 2. A proximity monitor as claimed in claim 1, further comprising a pass detection device configured to detect one of the vehicle and the proximate vehicle passing the other, and wherein generating an alert signal comprises generating the alert signal if a passing detection or non-detection and the spacing information satisfy the alert criterion.
- 20 3. A proximity monitor as claimed in claim 1, further comprising a second RF receiver spaced apart from the first RF receiver, wherein the processor is configured to determine the bearing of the one or more proximate transmitters using triangulation.
- 25 4. A proximity monitor as claimed in claim 3, wherein generating an alert signal comprises generating the alert signal if the spacing information and the bearing information satisfy the alert criterion.

5. A proximity monitor as claimed in claim 1, further comprising a GPS receiver to determine position information,
wherein the processor is configured to compare the position information determined using the GPS receiver to position information associated with the proximate vehicle, and
5 wherein generating an alert signal comprises generating the alert signal if the spacing information and the position information satisfy the alert criterion.
6. A proximity monitor as claimed in claim 1, wherein the processor is
10 configured to compare the location of the proximity monitor to a location-based rule and generate the alert signal based on the comparison.
7. A proximity monitor as claimed in claim 1, further comprising a Bluetooth communications module for transmitting and receiving position information.
8. A proximity monitor as claimed in claim 1, wherein the alert criterion
15 comprises whether the proximate vehicle has been in the monitored zone for greater than a defined amount of time.
9. A proximity monitor as claimed in claim 1 wherein the first RF transmitter is, or each of the first and second RF transmitters is, an ultrawideband (UWB) transmitter, and wherein the first RF receiver is a UWB receiver.
- 20 10. A proximity monitor as claimed in claim 1, comprising a long-range communication module configured to communicate the alert signal to a remote device and receive a penalty signal from the remote device.
11. A proximity monitor as claimed in claim 1, further comprising a user
25 indicator configured to indicate when a penalty signal is received at the proximity monitor.

12. A proximity monitor as claimed in claim 11, wherein the user indicator is configured to generate an audible signal or a visual signal.
13. A proximity monitor as claimed in claim 1, further comprising a visual or audible indicator to indicate to a user of the proximate vehicle when the alert signal has been generated.
14. A proximity monitor as claimed in claim 1, further comprising a camera, and wherein the proximity monitor is configured to transmit an output of the camera to a remote device upon determination of an alert condition.
15. A proximity monitor as claimed in claim 1, wherein the processor is further configured to determine information indicative of an amount of time spent by the proximate vehicle in the monitored zone.
16. A race communication system comprising:
- a plurality of vehicles, each vehicle including a proximity monitor as claimed in claim 1 and a user indicator; and
 - one or more remote devices, each including an RF transceiver and a user interface;
- wherein the proximity monitor of each vehicle is configured to:
- transmit a signal to the remote device based on the spacing between the vehicle and a proximate vehicle;
- and wherein the remote device is configured to:
- receive the signal from the vehicle using the RF transceiver,
 - present information based on the spacing between the vehicle and the proximate vehicle to a user via the user interface;
 - receive an input from the user via the user interface;

generate a penalty signal based on the input from the user; and
wherein the penalty signal indicates that a penalty is to be applied to
the proximate vehicle or a user thereof.

- 5 17. A race communication system as claimed in claim 16, wherein each of the
vehicles is provided with a camera, and wherein each of the vehicles is
configured to transmit visual images recorded by the camera to the remote
device.
- 10 18. A race communication system as claimed in claim 16, further comprising a
user indicator configured to present a visible or audible signal to the
proximate vehicle or a user thereof.
19. A race communication system as claimed in claim 16, wherein the remote
computer is configured to record an amount of time spent by a vehicle in the
monitored zone associated with another vehicle.
- 15 20. A race communication system as claimed in claim 16, further comprising a
penalty enforcement system, wherein the penalty enforcement system
comprises: a communications interface configured to receive the penalty
signal from the remote device;
a processor configured to determine whether the proximate vehicle of user
thereof has fulfilled requirements of the penalty.
- 20 21. A proximity monitor comprising:
- a. a RF transmitter configured to periodically communicate data with
proximate RF receivers;
 - b. a RF receiver configured to acquire signal timing information from
signals transmitted by proximate RF transmitters to develop spacing
25 information as to the spacing between proximate transmitter and
receiver pairs;

36

- c. a GPS receiver for obtaining GPS position information;
 - d. a processor configured to:
 - i. receive the GPS position information and spacing information,
 - ii. provide this information to the transmitter to communicate with proximate receivers,
 - iii. receive GPS position information and spacing information received by the receiver from proximate transmitters; and
 - iv. develop an alert signal if position and spacing information satisfies an alert criterion.
- 5
- 10 22. A proximity monitor as claimed in claim 21 wherein the RF transmitters and receivers are UWB transmitters and receivers.
23. A proximity monitor as claimed in claims 21 or 22, including a rearwardly facing visual indicator which is activated when a proximity monitor of a following vehicle satisfies an alert condition.
- 15 24. A proximity monitor as claimed in any one of claims 21 to 23 including a user indicator to indicate that the alert signal has been generated.
25. A proximity monitor as claimed in any one of claims 21 to 24 wherein the GPS position information is used to generate information about the ordering of proximity monitor devices along a race course.
- 20 26. A proximity monitor as claimed in claim 25 wherein the GPS position information is used to determine whether the proximity monitor is travelling at a speed at which the processor should develop the alert signal.
- 25 27. A proximity monitor as claimed in any one of claims 21 to 26 wherein the GPS position information is used to determine whether the proximity

monitor is in a zone in which the processor should develop the alert signal.

- 5 28. A proximity monitor as claimed in any one of claims 21 to 27 wherein the period of time that the spacing between proximity monitors has remained within a defined range is also used by the processor to develop the alert signal.
29. A proximity monitor as claimed in any one of claims 21 to 28 wherein the GPS position information is used to determine whether the proximity monitor device has entered a defined penalty serving area.
- 10 30. A proximity monitor as claimed in claim 29 wherein, when the processor determines that the proximity monitor has incurred a penalty, the user indicator indicates that the penalty is active until the penalty has been completed.
- 15 31. A proximity monitor as claimed in any one of claims 21 to 30 including a pair of RF receivers spaced apart from one another wherein the processor determines the orientation of a transmitter with respect to the proximity monitor using triangulation.
- 20 32. A proximity monitor comprising:
- a. a RF transmitter configured to periodically communicate with proximate receivers;
 - b. a RF receiver configured to acquire signal timing information from signals transmitted by proximate transmitters to develop spacing information as to the spacing between proximate transmitter and receiver pairs;
 - 25 c. a processor configured to:
 - i. receive the spacing information, and

- ii. develop an alert signal if the spacing information satisfies an alert criterion.

33. A proximity monitor as claimed in claim 32 wherein the RF transmitters and receivers are UWB transmitters and receivers.

5 34. A proximity monitor as claimed in claims 32 or 33, including a rearwardly facing visual indicator which is activated when a proximity monitor of a following vehicle satisfies an alert condition.

10 35. A proximity monitor as claimed in claims 32 to 34 wherein the alert condition is based on a period of time that the spacing between proximity monitors has remained within a defined range.

36. A proximity monitor as claimed in claims 32 to 35 including a pair of RF receivers spaced apart from one another wherein the processor determines the orientation of the monitor with respect to a proximate transmitter using triangulation.

15 37. A proximity monitor as claimed in claims 32 to 35, wherein the signal timing information from three or more proximate transmitters is used to develop information as to the spacing between the receiver and the three or more transmitters.

20 38. A proximity monitor having a front and rear to be aligned with the front and rear of a vehicle in use, comprising:

- a. a proximity detector for detecting the proximity of a second proximity monitor; and
- b. a processor for generating an alert signal when a proximity based criteria is satisfied; and
- 25 c. a light driven when the alert signal is generated oriented to project light from the rear of the detector.

39. A proximity monitor as claimed in claim 38 wherein the alert signal is generated based on the proximity of a following proximity monitor.

40. A proximity monitor as claimed in claims 38 to 39 wherein the proximity
5 detector is a proximity monitor as claimed in any one of claims 21 to 37.

41. A passing detector comprising:

- a. a housing for mounting to a vehicle;
- b. a GPS receiver for obtaining GPS position information;
- c. one or more lights generating lateral beams from the sides;
- 10 d. one or more detectors which detect the presence of light incident on the sides and generate a detection signal when specified characteristics of incident light are detected; and
- e. a processor configured to:
 - i. receive the GPS position information;
 - 15 ii. receive the detection signal; and
 - iii. generate an alert signal.

42. A passing detector as claimed in claim 41 wherein the passing alert signal is generated if the GPS position information and the detection signal timing satisfies alert criteria.

20 43. A passing detector as claimed in claims 41 or 42 wherein the processor is also configured to provide GPS, detection and alert information to a transceiver to transmit to proximate receivers.

44. A passing detector as claimed in claims 41 to 43 wherein the processor is also configured to receive GPS position information and spacing information received by the transceiver from proximate transmitters.
- 5 45. A passing detector as claimed in claims 41 to 44 wherein the GPS position information is used to generate information about the ordering of passing detector devices along a race course.
46. A passing detector as claimed in claims 41 to 45 wherein the GPS position information is used to determine whether the detector function of the passing detector device is enabled or disabled.
- 10 47. A passing detector as claimed in claim 46 wherein the GPS position information is used to determine whether the proximity monitor is travelling at a speed at which whether the detector function of the passing detector device is enabled or disabled.
48. A passing detector as claimed in claim 46 wherein the GPS position information is used to determine whether the passing detector device has entered a pre-defined penalty zone.
- 15 49. A passing detector as claimed in claims 41 to 48 including:
- a. a housing having a front and rear to be aligned with the front and rear of a vehicle in use; and
 - 20 b. a light driven when an alert signal is generated directed to project light from the rear of the detector.
50. A proximity monitor or passing detector as claimed in any previous claim wherein the alert signal also generates an audio signal.
- 25 51. A proximity monitor or passing detector as claimed in any one of claims 20 to 50 which also includes a front-facing camera.

41

52. A proximity monitor or passing detector as claimed in any one of claims 20 to 51 which also includes a rear-facing camera.
53. A proximity monitor or passing detector as claimed in any one of claims 20 to 52 which also includes an impact detector and a means of communicating impact events.
54. A proximity monitor or passing detector as claimed in any one of claims 20 to 53 which also includes a wireless charging system.
55. A proximity monitor or passing detector as claimed in any one of claims 20 to 54 which also includes a means of communicating with biometric or other telemetry devices.
56. A method of determining the relative positions of a first and second vehicle, each having a RF transceiver and a GPS receiver comprising:
- a. determining the positions of vehicles based on GPS signals received by each GPS receiver;
 - b. determining the spacing between vehicles based on the timing of signals between transceivers; and
 - c. developing an alert signal if position and spacing information satisfies an alert criterion.
57. A method of determining the relative positions of a first and second vehicle as claimed in claim 56, wherein the spacing between vehicles is determined based on the timing of signals between 3 or more transceivers.
58. A method of determining the relative positions of a first and second vehicle as claimed in claim 56 or 57, wherein historical spacing data and historical GPS data is used to determine the relative positions of the first and second vehicle.

59. A method of determining the relative positions of a first and second vehicle as claimed in claims 56 to 58, wherein the RF transceiver and the GPS receiver are included in a proximity monitor as claimed in claims 21 to 31.
- 5 60. A vehicle ordering method to be used between two race vehicles wherein each vehicle includes:
- a. front-mounted forward facing optical detector; and
 - b. a rear-mounted and rear-facing optical transmitter,
- 10 whereby the rear-facing optical transmitter transmits a beam that identifies the race vehicle associated with the optical transmitter, and whereby the leading race vehicle transmits its identifying code to the detector of the trailing race vehicle, which the front-mounted detector detects when it is within a beam transmitted rearwardly by the rear-facing optical transmitter.
- 15 61. A vehicle ordering method as claimed in claim 60 wherein the rear-facing optical transmitter transmits light which is spectrally and/or spatially and/or temporally modulated.
- 20 62. A vehicle ordering method as claimed in claim 60 or 61, wherein each race vehicle includes a proximity monitor as claimed in claims 21 to 40 or claims 50 to 55, or a passing detector as claimed in claims 61 to 65.
63. A method of indicating a rules infraction between two vehicles by producing a visual signal from the rear of a leading vehicle when a rules infraction between the two vehicles is detected.
- 25 64. A method of indicating a rules infraction between two vehicles as claimed in claim 44 using a proximity monitor as claimed in claims 21 to 31 or claims 50 to 55, or a passing detector as claimed in claims 41 to 55.

65. A race communication system comprising:

- a. a plurality of race vehicles, each including an RF transceiver;
- b. at least one fixed RF transceiver, located at a known location around the race course;
- 5 c. a central computing device; and
- d. a display device.

wherein each RF transceiver is configured to:

- i. communicate with other RF transceivers;
- ii. communicate location information between other RF transceivers;
- 10 iii. communicate with the central computing device either directly or via at least one other RF transceiver; and
- iv. communicate penalty information between other RF transceivers.

66. A race communication system as claimed in claim 65 wherein the at least one fixed RF transceivers is also configured to determine race vehicle locations using triangulation between two fixed RF transceivers and one race vehicle-mounted RF transceiver.

67. A race communication system as claimed in claim 65 or 66 wherein the central computing device monitors information from the plurality of race vehicles and checks this information against race-based rules.

20 68. A race communication system as claimed in claim 65 to 67 wherein the computing device provides information from the plurality of vehicles and other race-based information to the display device.

69. A race communication system as claimed in claims 65 to 68 wherein the race vehicle RF transceivers are included in proximity monitors as claimed in claims 21 to 40 or claims 50 to 55.

70. A pass detecting system comprising:

- a. a plurality of position detectors, each including:
 - i. a housing for mounting to a vehicle;
 - ii. a GPS receiver for obtaining GPS position information;
 - 5 iii. one or more light generating lateral beams from the sides;
 and
 - iv. one or more detectors which detect the presence of light
 incident on the sides and generates a detection signal when
 specified characteristics of incident light are detected; and
- 10 b. a central computer in communication with the position detectors
 which receives the GPS position information and detection
 signals from at least some of the position detectors and develops
 an alert signal if GPS position information and detection signal
 timing satisfies alert criteria.

15 71. A pass detection system as claimed in claim 70, wherein the plurality of
 position detectors are passing detectors as claimed in claims 41 to 55.

72. An on-course penalty enforcement system, comprising:

- a. a race communication system;
- b. a penalty alerting device; and
- 20 c. a plurality of penalty detection devices,

wherein the plurality of penalty detection devices are configured to detect
a rule infraction and communicate via the race communication system to
the penalty alerting device, and wherein the penalty alerting device
displays a penalty alert to a user.

45

73. A system for enforcing an on-course penalty as claimed in claim 72 wherein the race communication system is a race communication system as claimed in claim 65.

5 74. A system for enforcing an on-course penalty as claimed in claim 72 or 73 wherein the plurality of penalty detection devices are proximity monitors as claimed in claims 21 to 40 or claim 45 to 49, or passing detectors as claimed in claims 41 to 49.

10 75. A system for enforcing an on-course penalty as claimed in claim 72 to 74 wherein the penalty alerting device is a proximity monitor as claimed in claims 21 to 40 or claim 45 to 49, or a passing detector as claimed in claims 41 to 49.

15 76. A system for enforcing an on-course penalty as claimed in claim 72 to 74 wherein the penalty alerting device is a visual display device that is configured to output to or communicate with the race communication system.

77. A method of enforcing an on-course penalty via a penalty alerting device comprising:

- 20
- a. detecting a rules infraction;
 - b. indicating the rules infraction to a user by notification via the penalty alerting device;
 - c. monitoring the position of the user;
 - d. determining when the user has satisfied a penalty condition; and
 - e. indicating the termination of the penalty to a user.

78. A method of enforcing an on-course penalty as claimed in claim 72 wherein indicating the termination of the penalty to a user consists of maintaining the notification until a prescribed penalty has been performed.
- 5 79. A method of enforcing an on-course penalty as claimed in claims 72 or 73 wherein indicating the termination of the penalty to a user consists of providing a second notification, different to the first, after a prescribed penalty has been performed.
- 10 80. A method of enforcing an on-course penalty as claimed in claims 72 to 74 wherein the penalty requires that the user remain within a geographical area for a prescribed time.
81. A method of enforcing an on-course penalty as claimed in claims 72 to 74 wherein the penalty requires that the user reduce their speed below a prescribed limit for a prescribed time.
- 15 82. A method of enforcing an on-course penalty as claimed in claims 72 to 74 wherein the penalty requires that the user remains stationary for a prescribed time.
83. A method of enforcing an on-course penalty as claimed in claims 72 to 74 wherein the penalty requires that the user maintains a prescribed separation from a leading vehicle for a
- 20 84. A method of enforcing an on-course penalty as claimed in claims 72 to 83 used with an on-course penalty enforcement system as claimed in claims 72 to 76.
85. A tracking device, configured to be temporarily attached to a wrist of a user, including:
- 25 an RF transceiver;
- an indicator; and

a GPS receiver module generating a GPS position signal,
wherein the RF transceiver is configured to communicate with a proximity
monitor as claimed in claims 21 to 37, claims 40 to 51, and claim 55.

- 5 86. A tracking device as claimed in claim 85 wherein the RF transceiver is a
Bluetooth transceiver.
87. A tracking device as claimed in claim 85 wherein the RF transceiver is also
configured to communicate with other fixed or mobile RF transceivers.
88. A tracking device as claimed in claim 87 wherein the RF transceiver is a
10 UWB transceiver.
89. A tracking device as claimed in claims 85 to 88, also including a cellphone
data transceiver, configured to communicate with a mobile phone
network.
90. A tracking device as claimed in claims 87 to 89 wherein the tracking device
15 can transmit the GPS position signal to other RF transceivers.
91. A tracking device as claimed in claims 85 to 90 wherein the indicator can
indicate warnings, penalties, or other race-based information to the user.
92. A tracking device as claimed in claim 91 wherein the indicator is configured
to generate vibrations that can be felt by the user.
- 20 93. A tracking device as claimed in claims 91 and 92 wherein the indicator is
configured to generate a visual indication to the user.
94. A tracking device as claimed in claims 91 to 93 wherein the indicator is
configured to generate an audio signal that can be heard by the user.

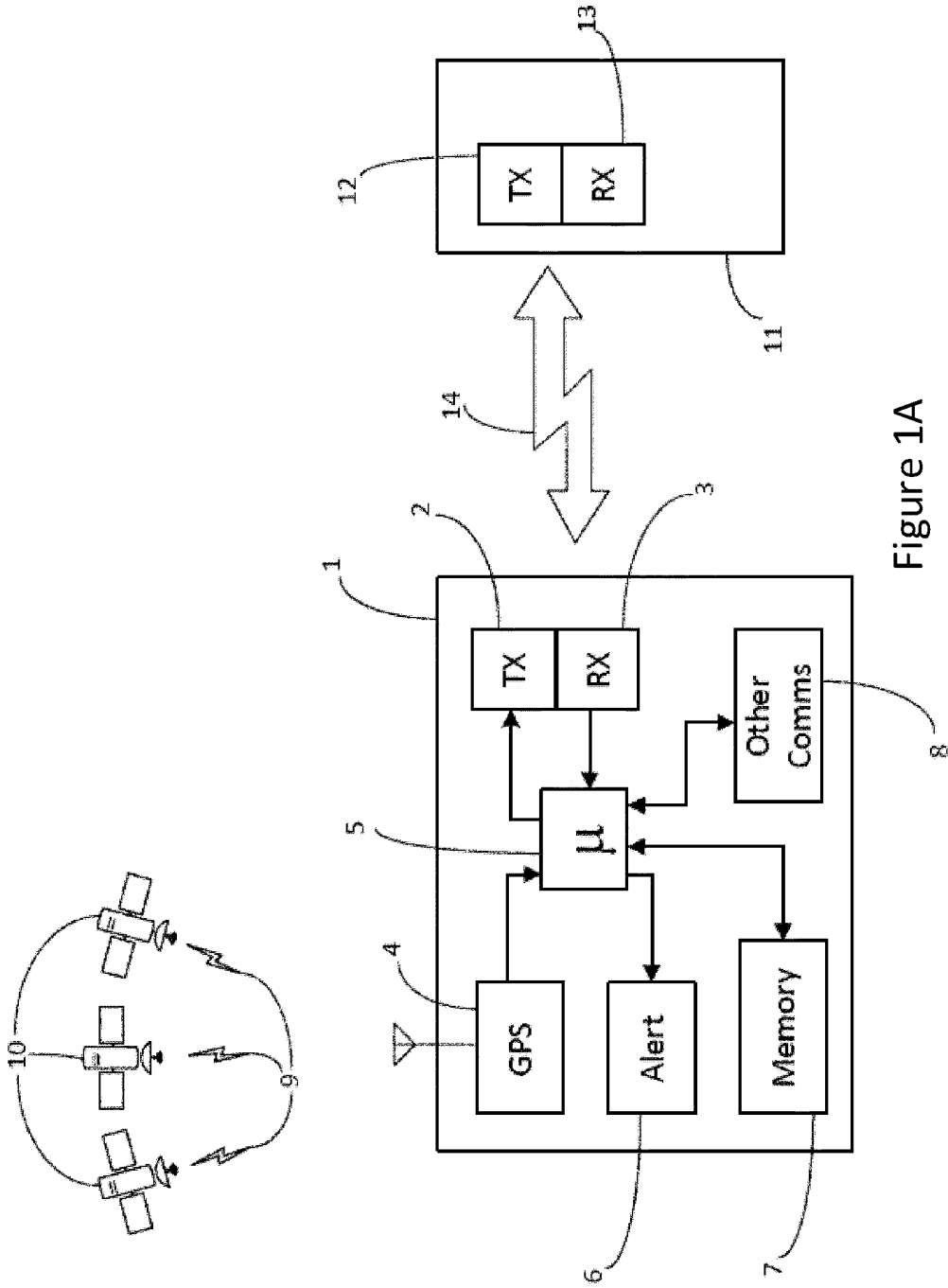

Figure 1A

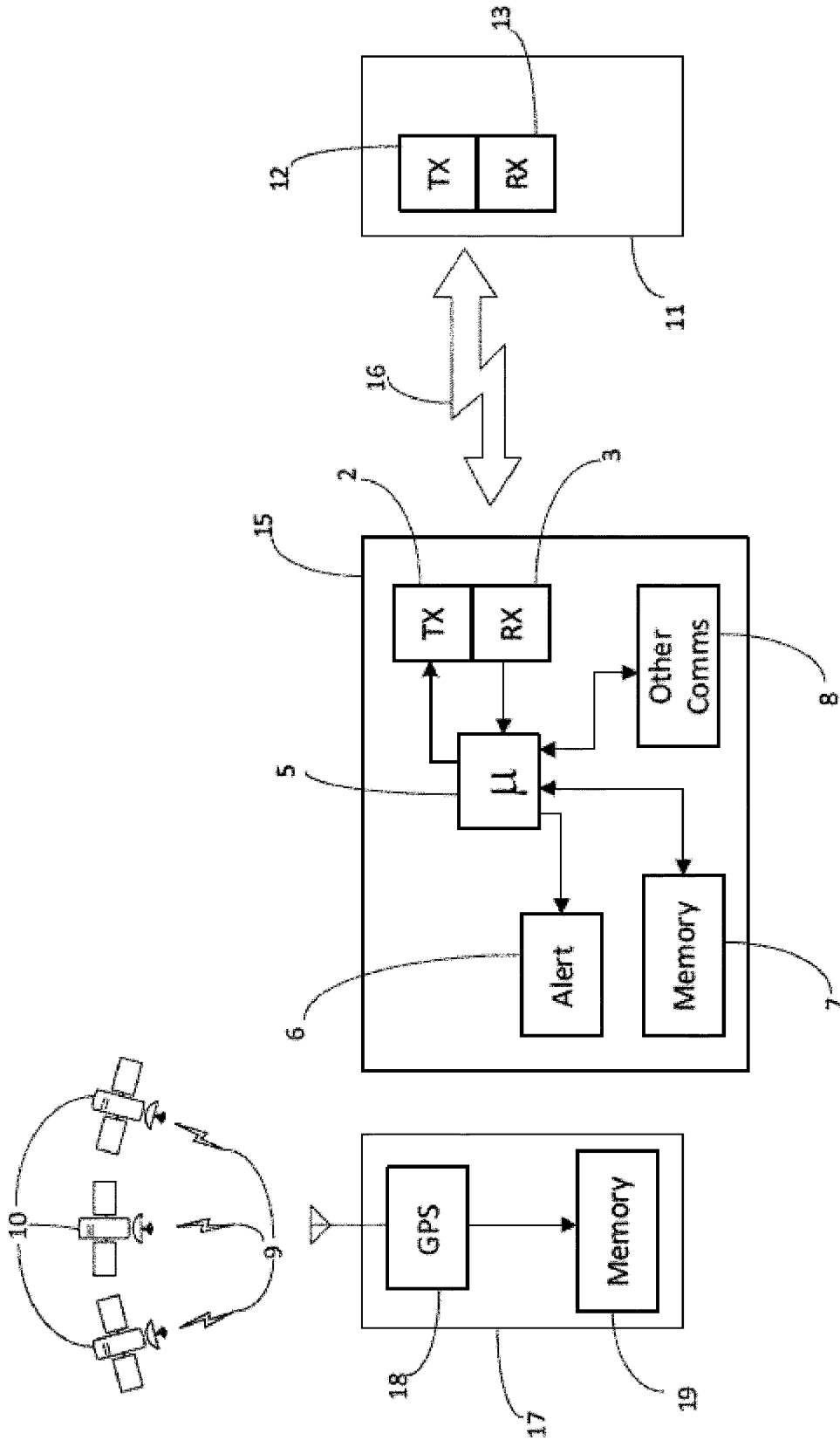

Figure 1B

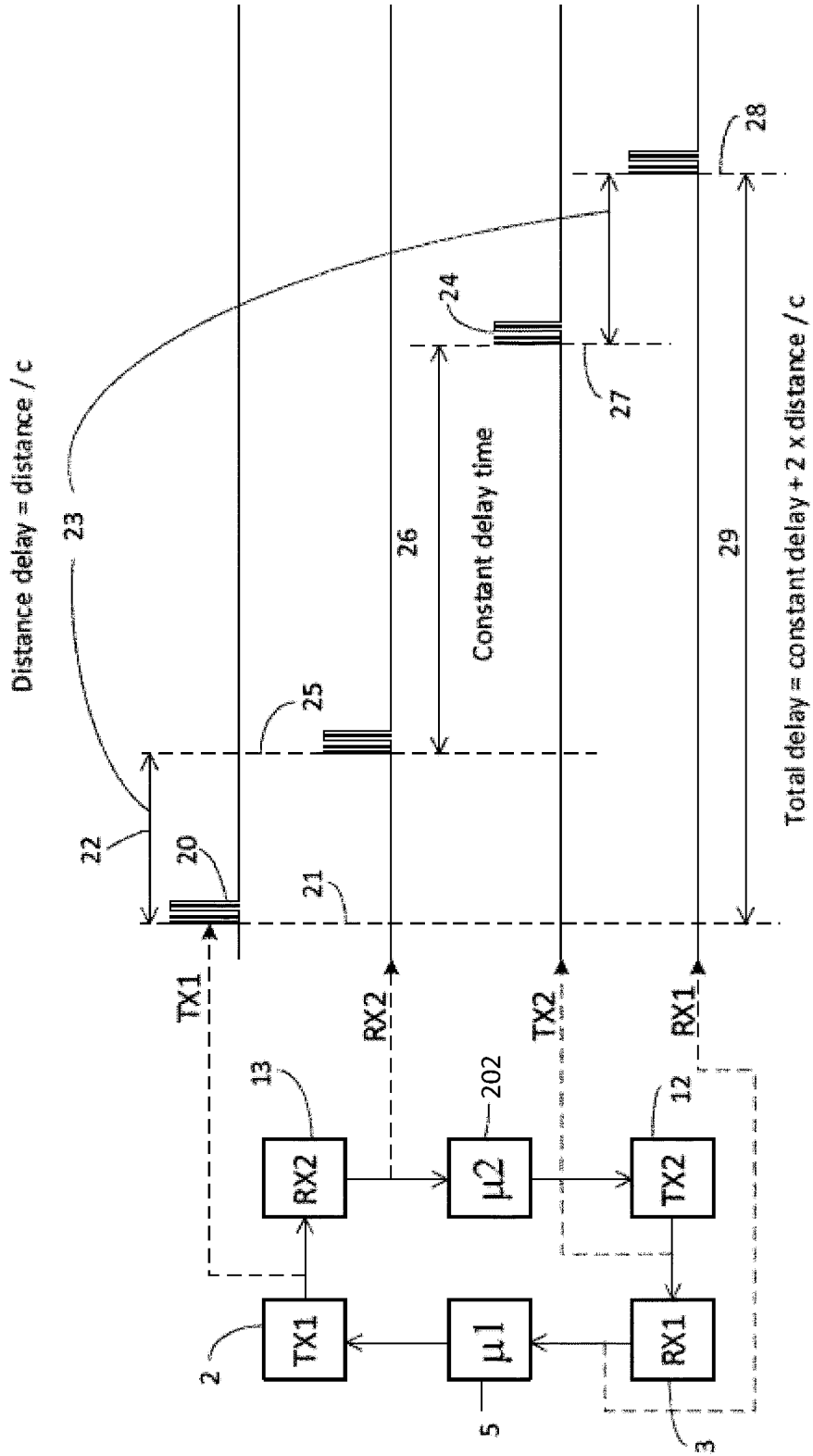

Figure 2

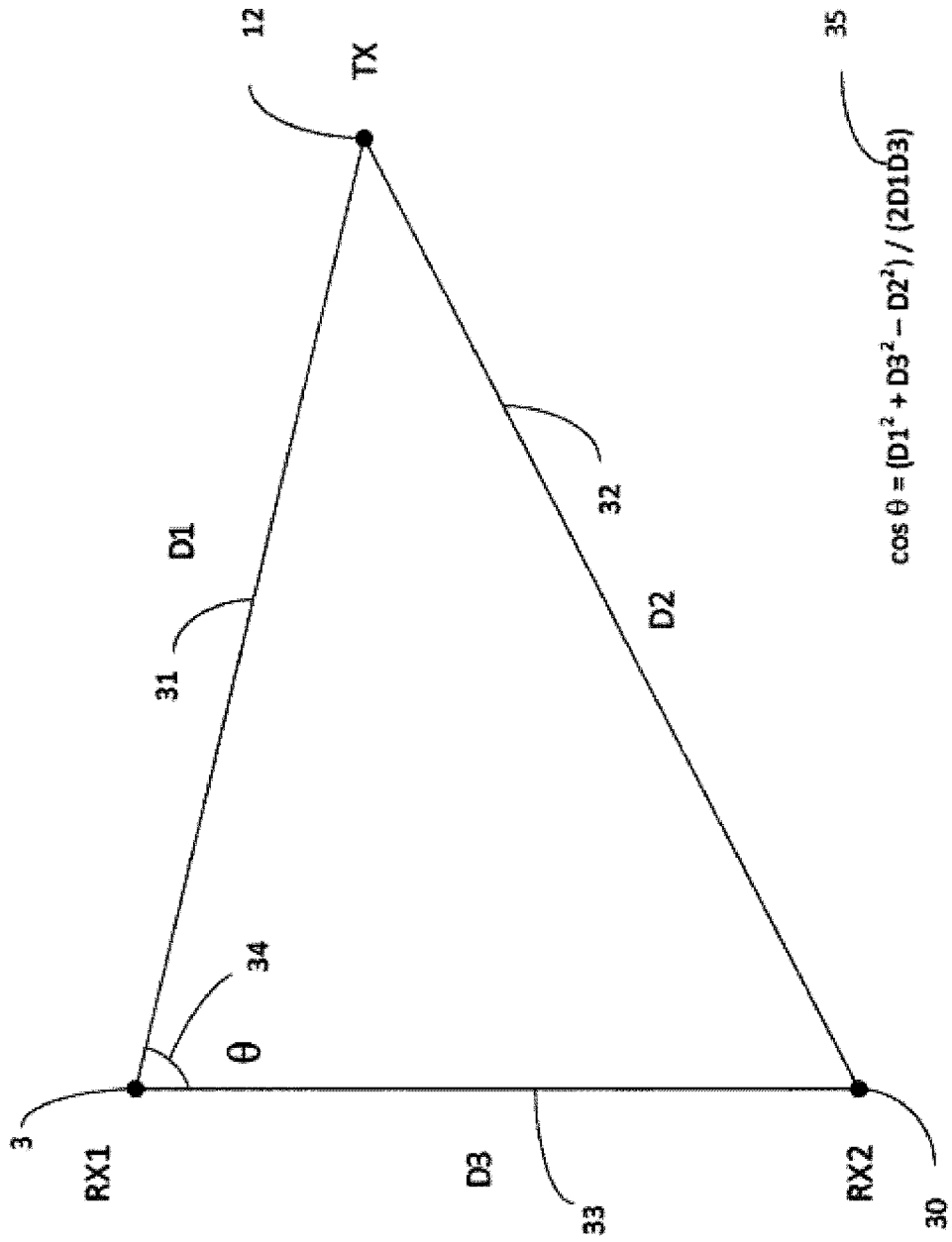

Figure 3A

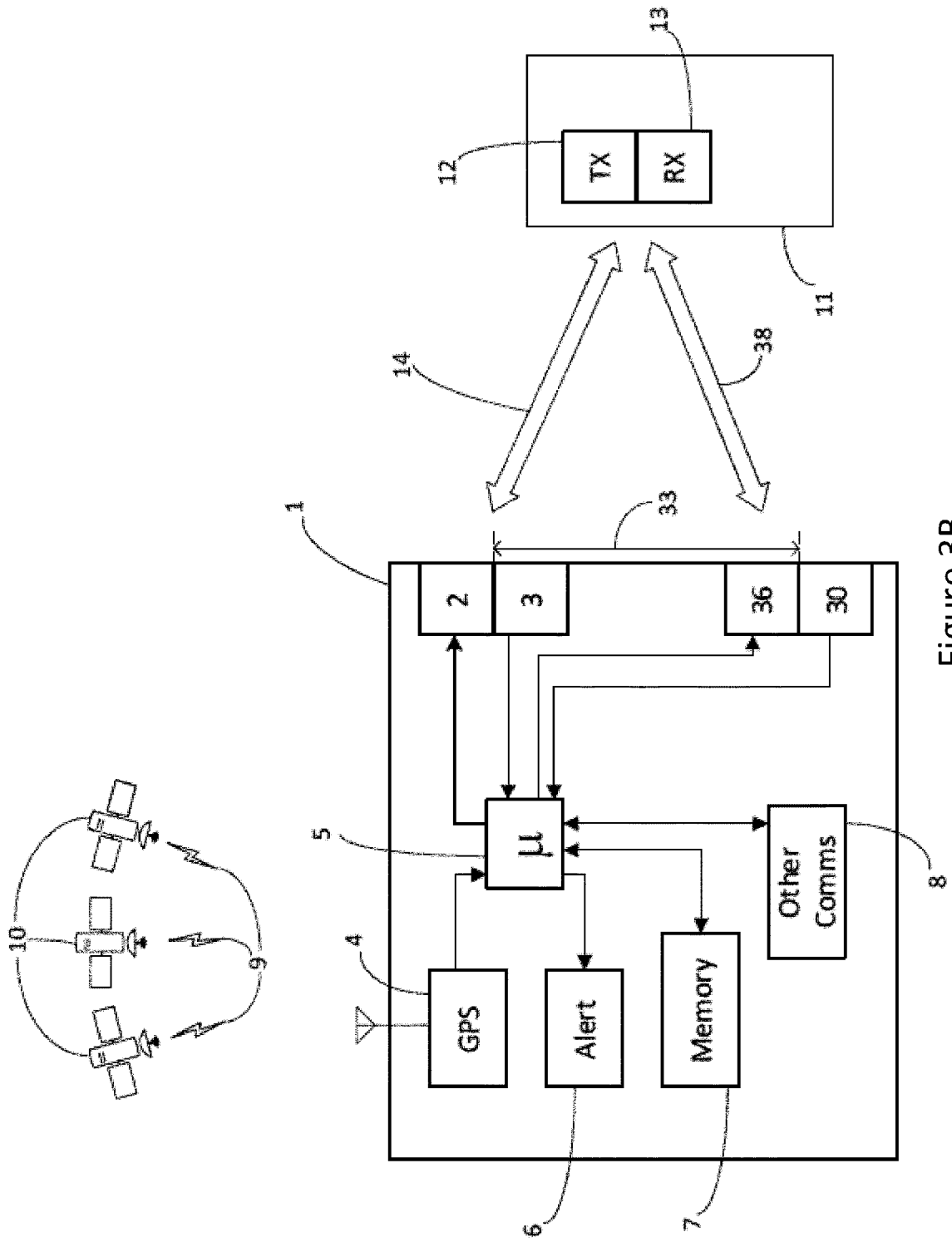

Figure 3B

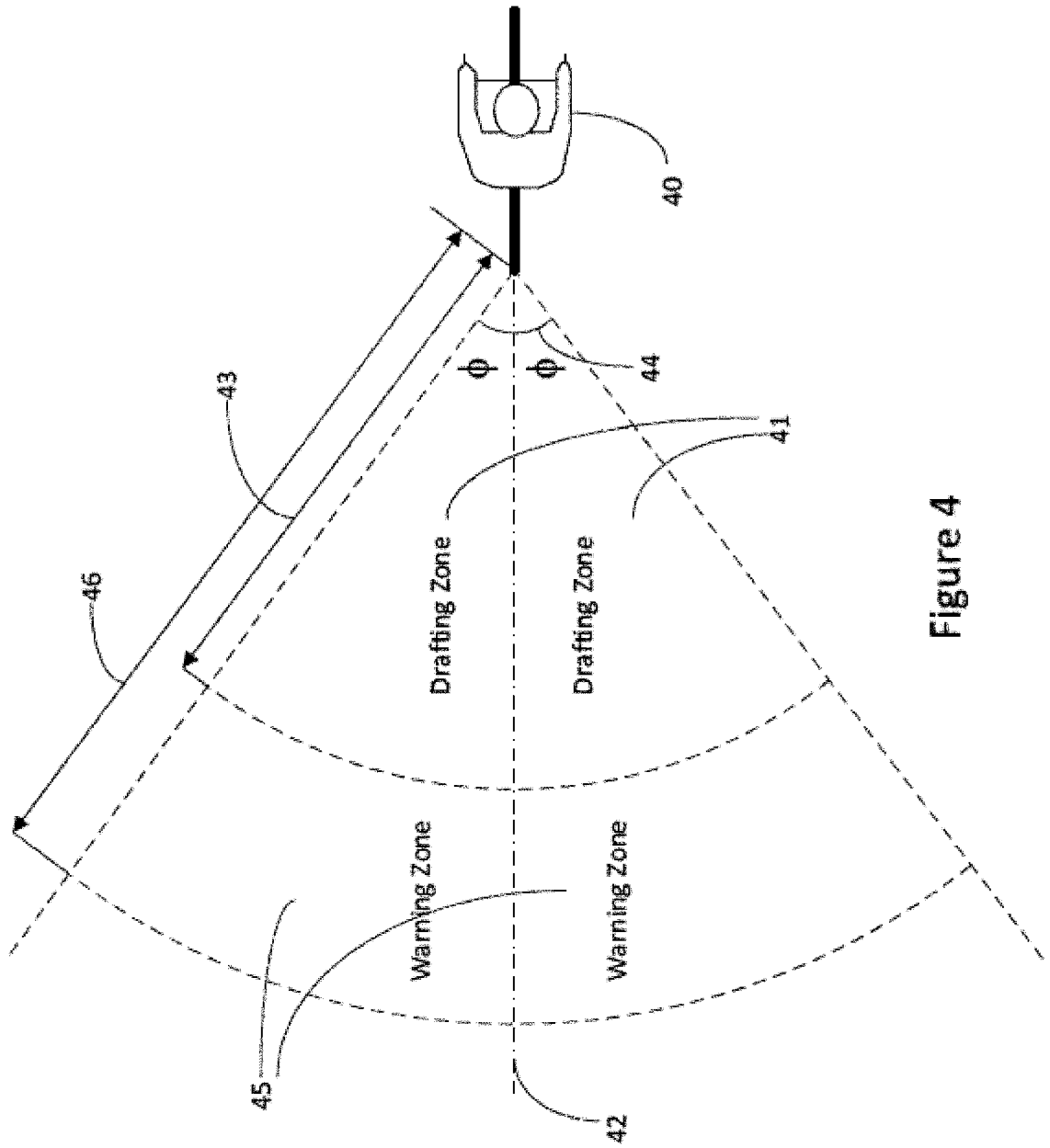

Figure 4

7 / 18

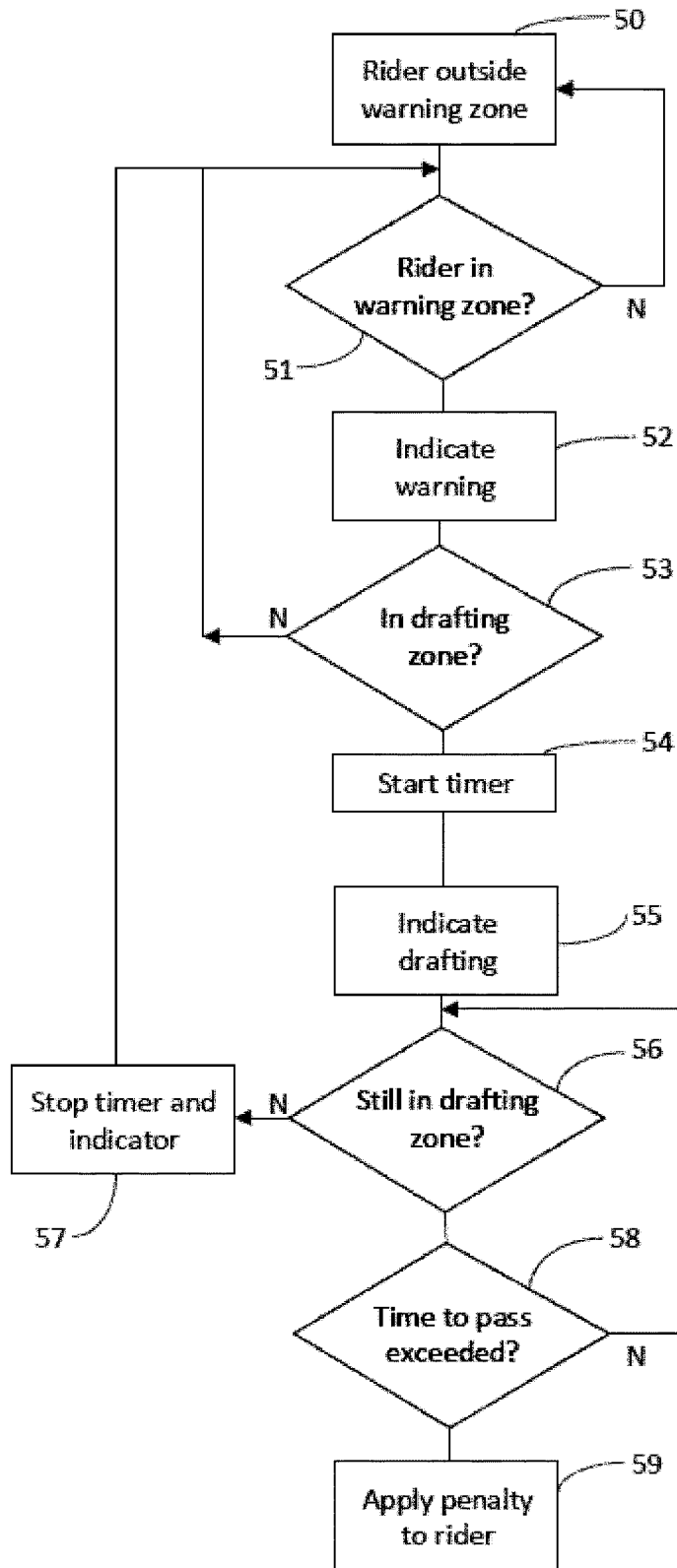

Figure 5

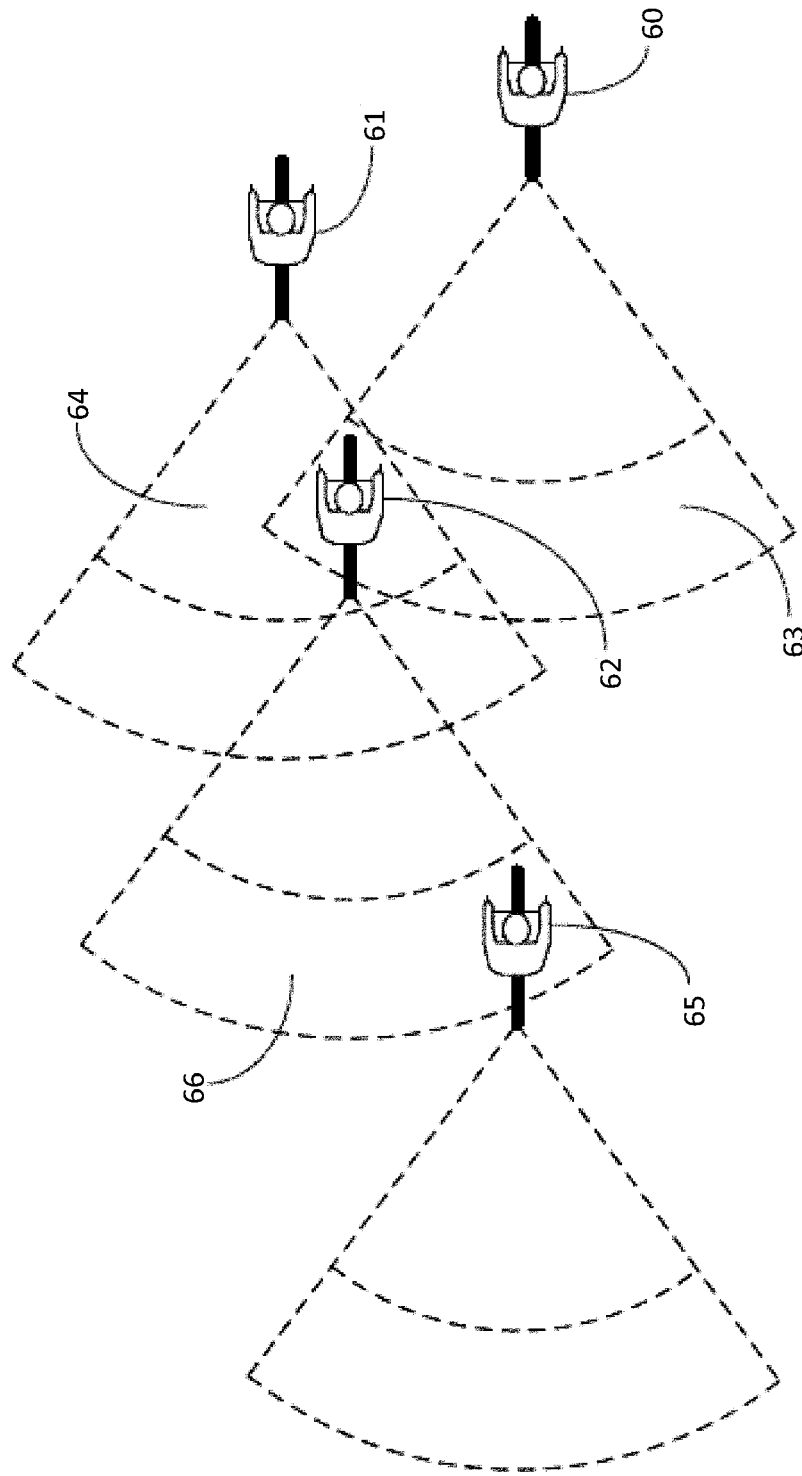

Figure 6

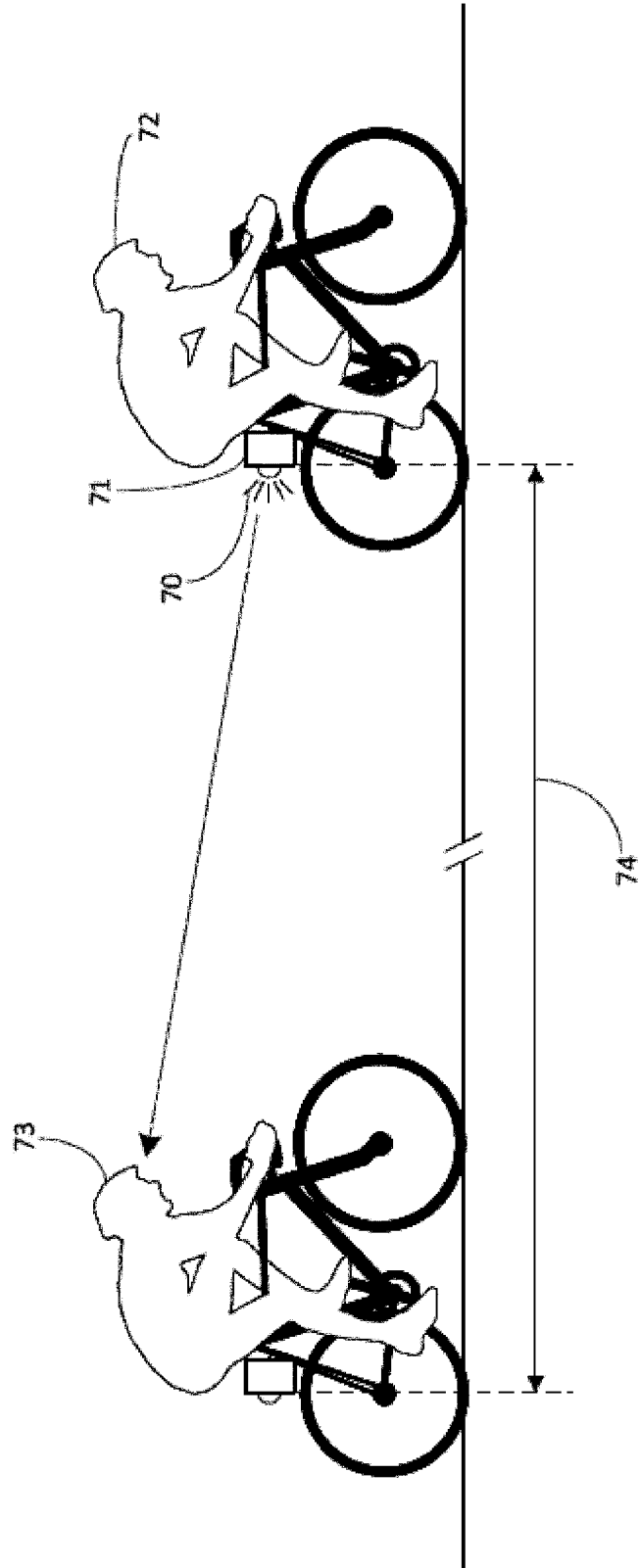

Figure 7

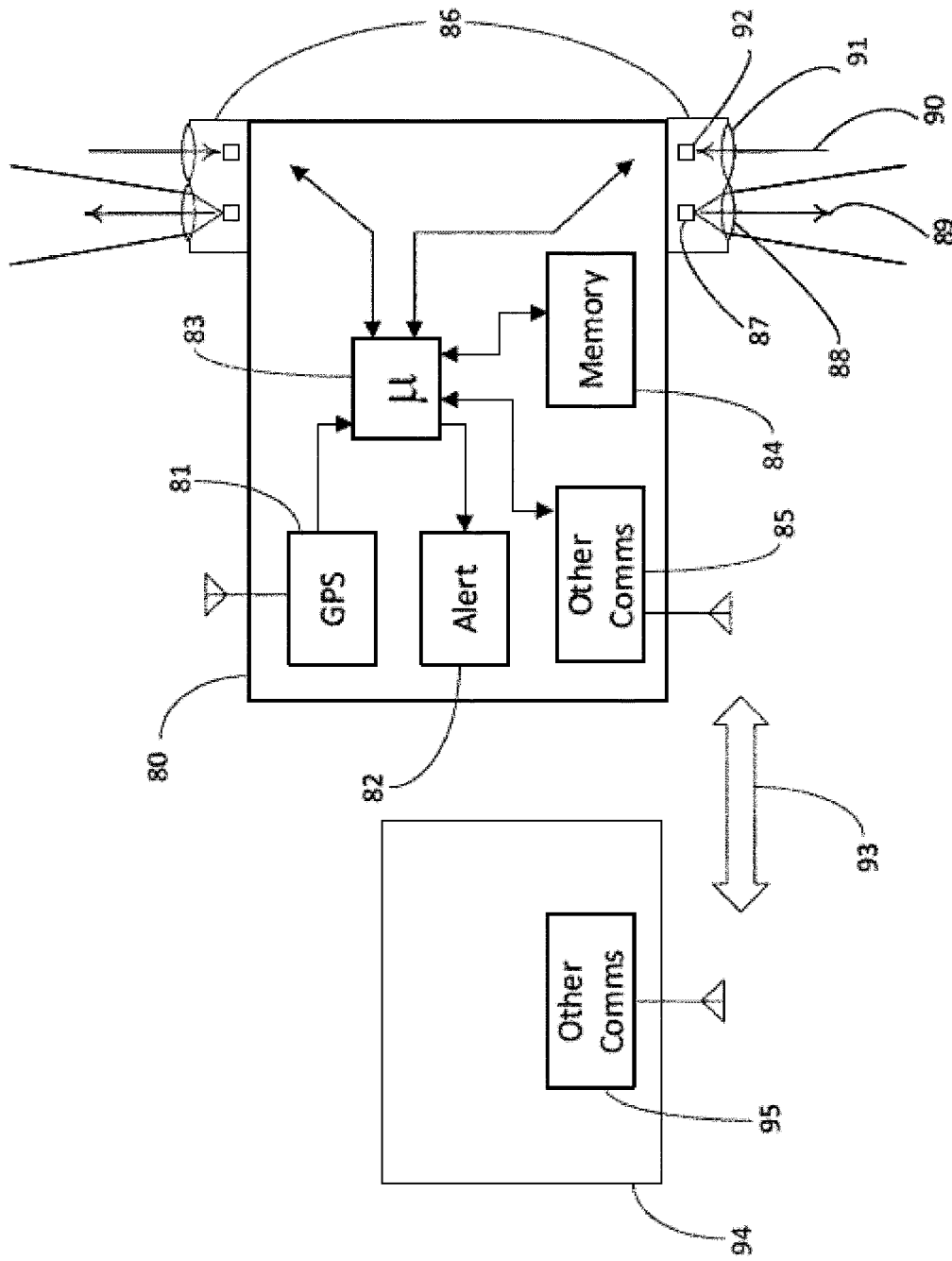

Figure 8

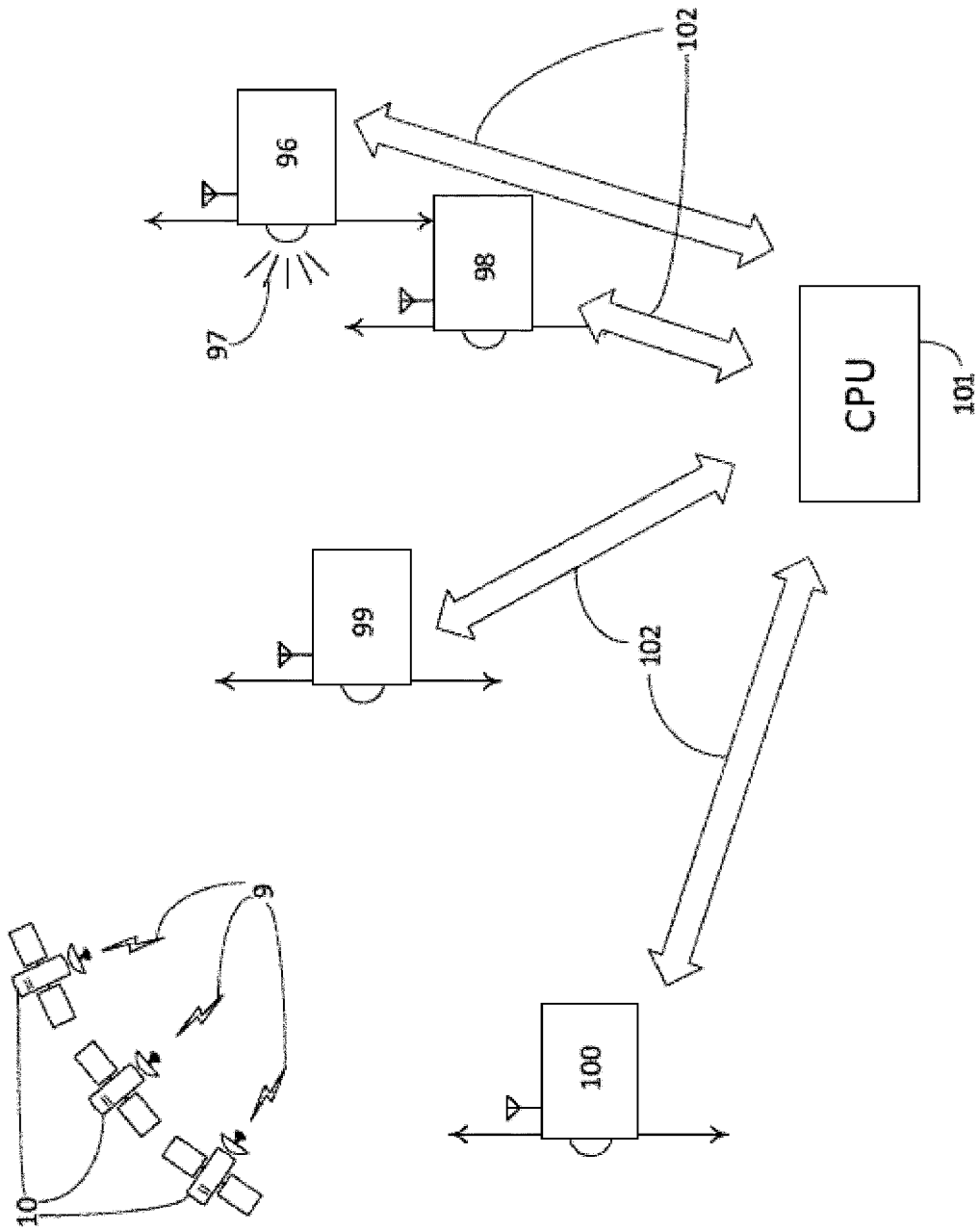

Figure 9

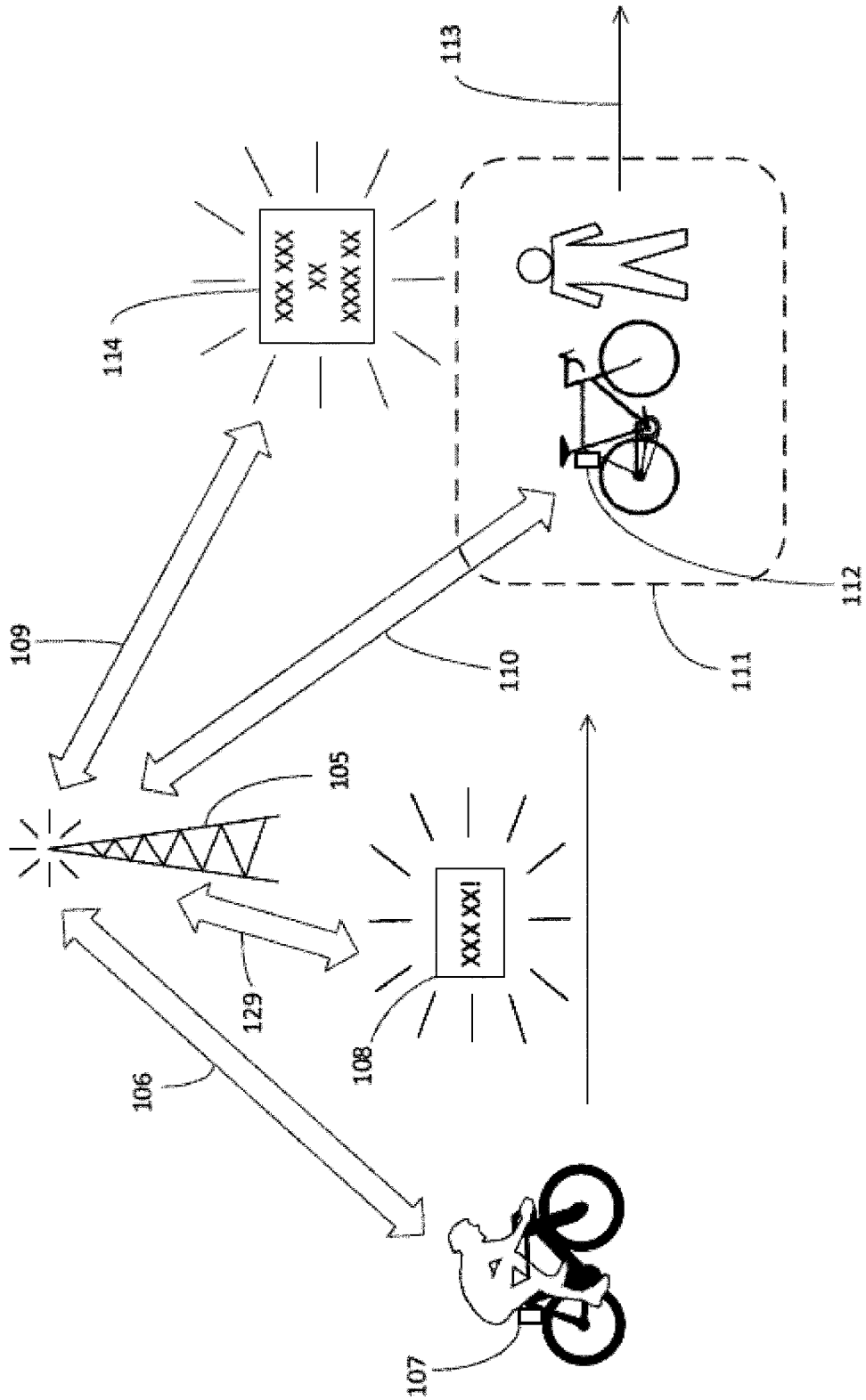

Figure 10A

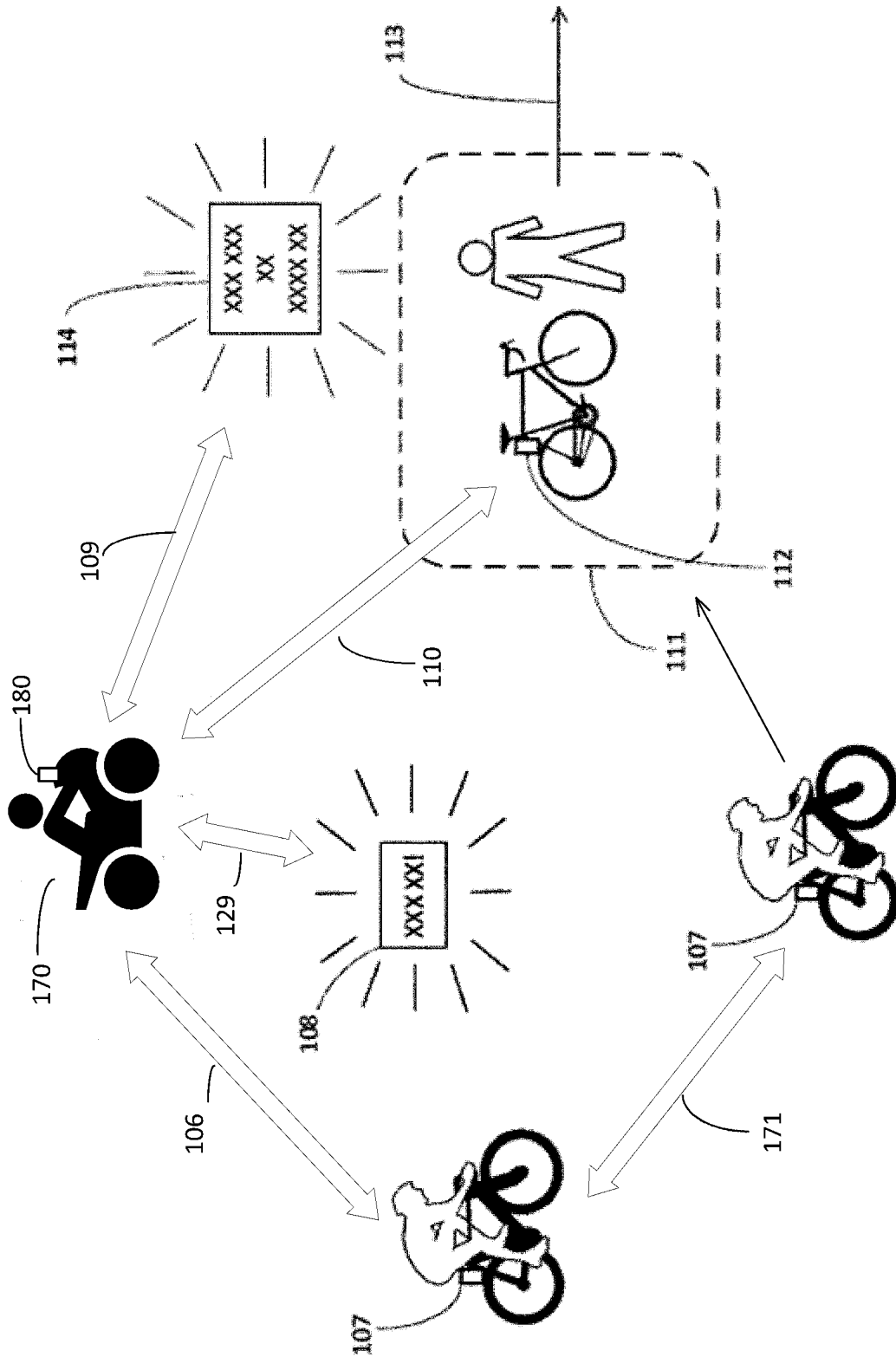

Figure 10B

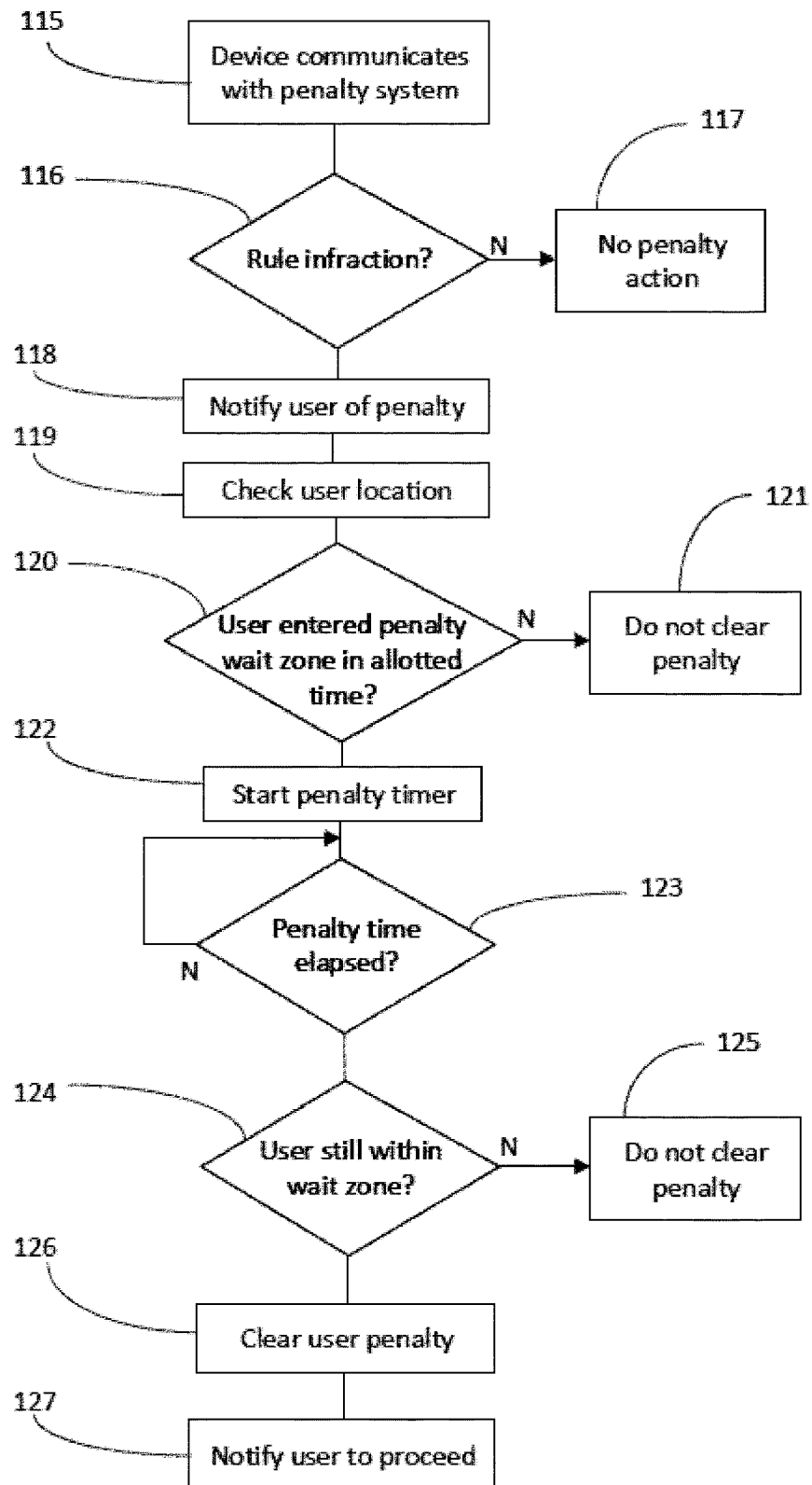

Figure 11

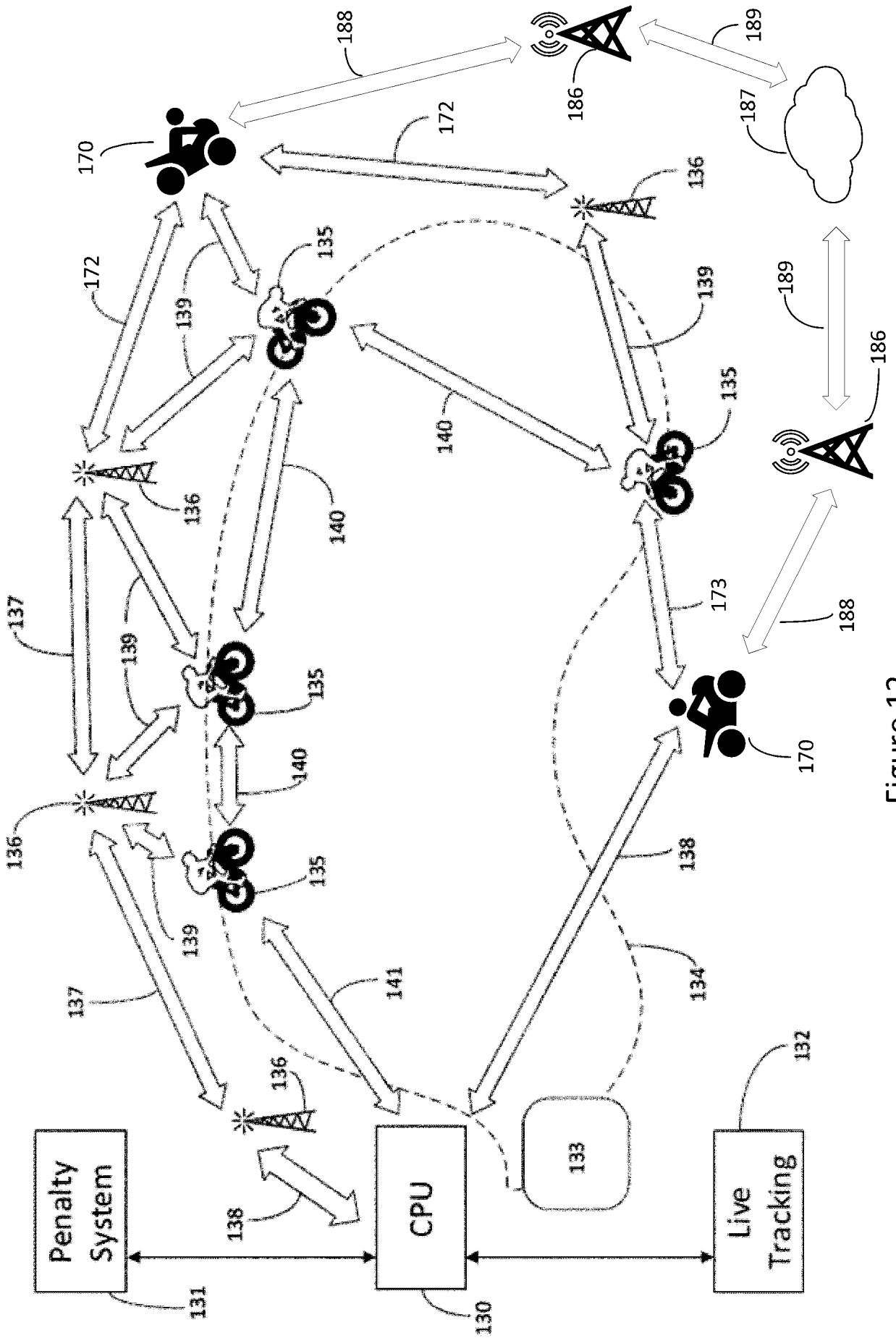

Figure 12

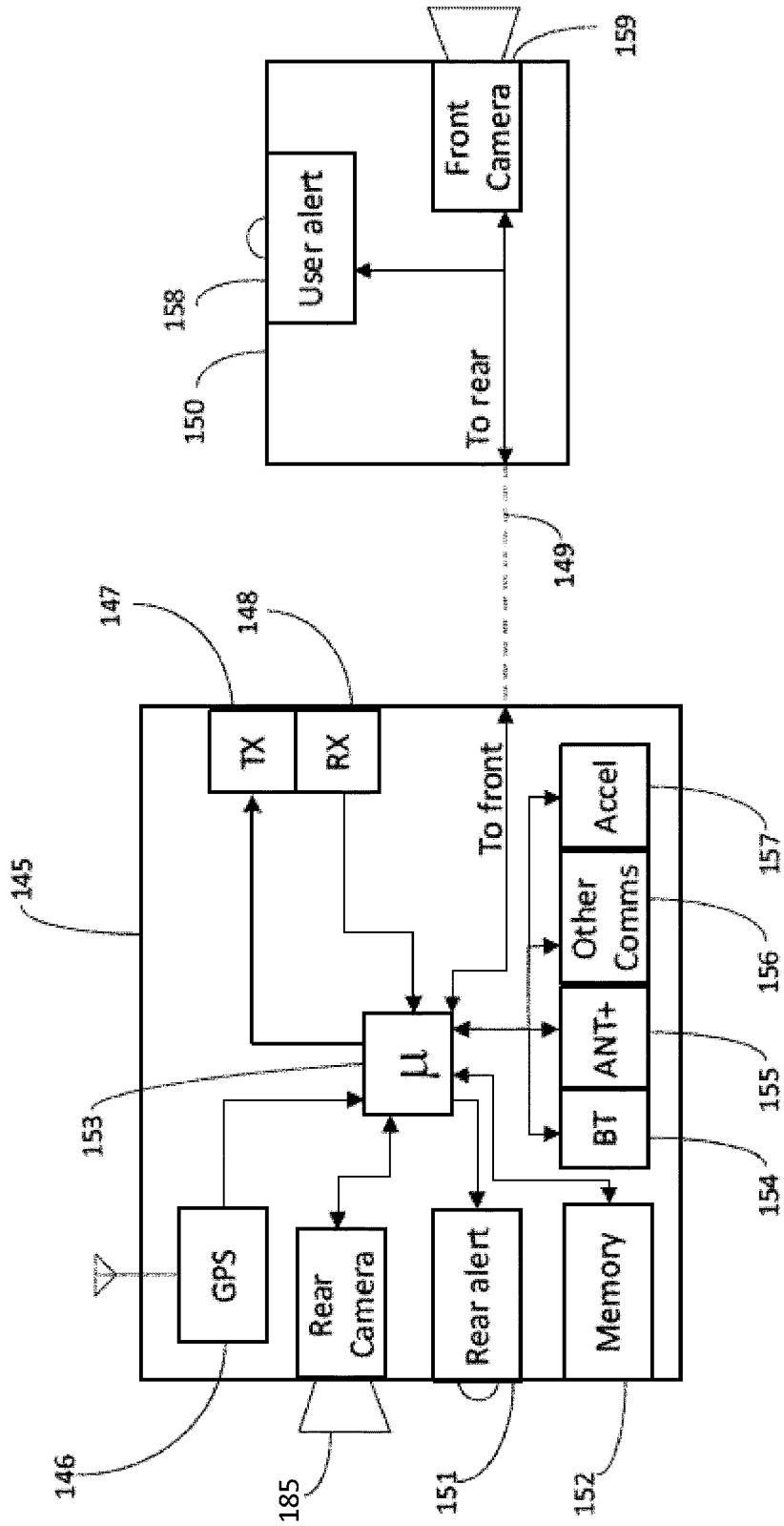

Figure 13

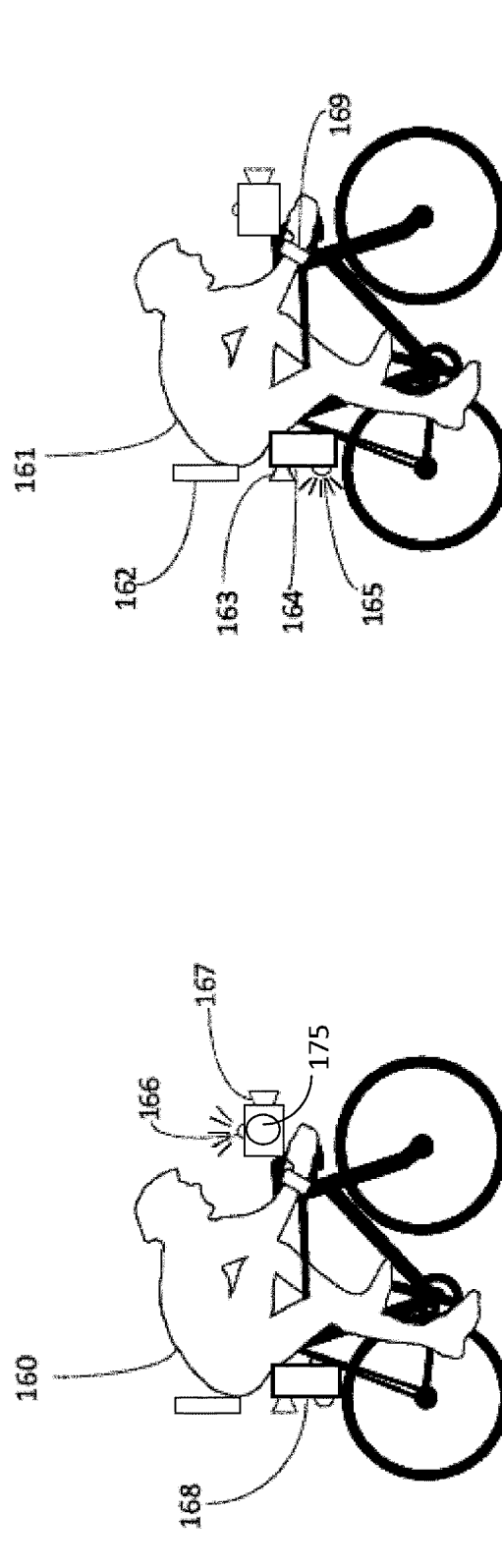

Figure 14

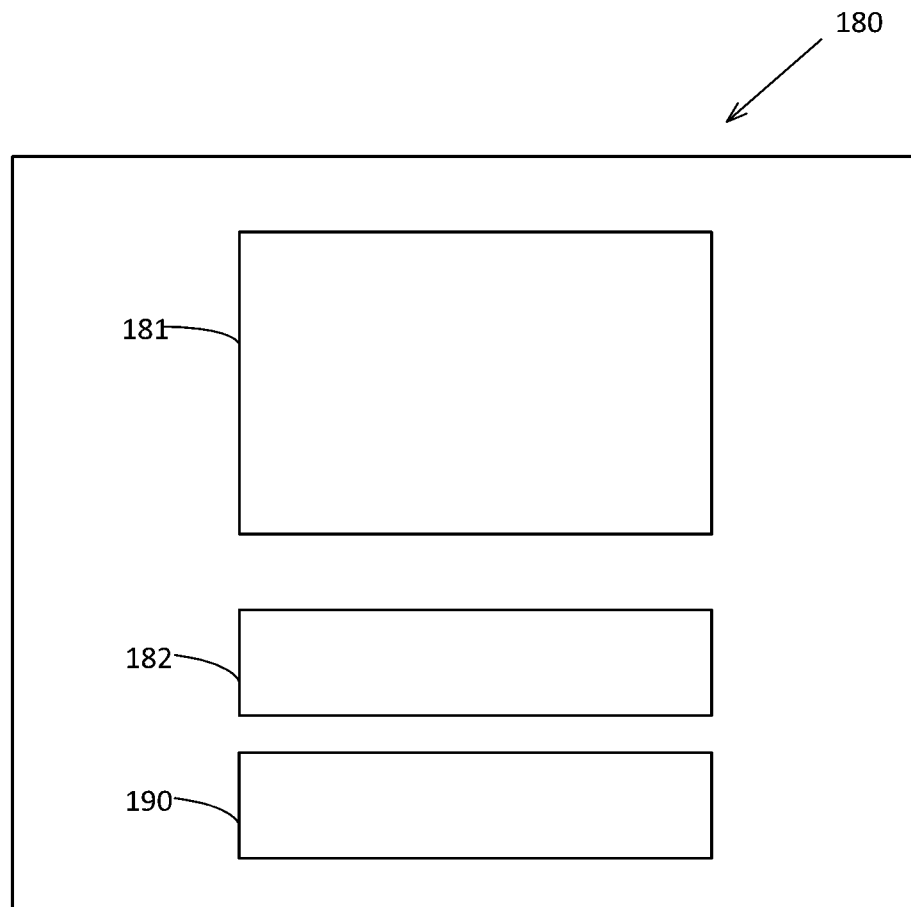

Figure 15

INTERNATIONAL SEARCH REPORT

International application No.

PCT/NZ19/50131

A. CLASSIFICATION OF SUBJECT MATTER

IPC - G08G 1/16, 1/123; A63K 3/00 (2020.01)

CPC - G08G 1/161, 1/22, 1/123; A63K 3/00

According to International Patent Classification (IPC) or to both national classification and IPC

B. FIELDS SEARCHED

Minimum documentation searched (classification system followed by classification symbols)

See Search History document

Documentation searched other than minimum documentation to the extent that such documents are included in the fields searched

See Search History document

Electronic data base consulted during the international search (name of data base and, where practicable, search terms used)

See Search History document

C. DOCUMENTS CONSIDERED TO BE RELEVANT

Category*	Citation of document, with indication, where appropriate, of the relevant passages	Relevant to claim No.
X -- Y --- A	WO 2006/079165 A1 (ALERT SYSTEMS PTY LTD) 03 August 2006, abstract, page 1 lines 4-7, page 3 lines 15-37, page 4 lines 34-37, page 5 lines 5-10, page 6 lines 20-30, page 7 lines 30-35, page 8 lines 9-15	1, 5-7, 9, 13 ----- 2-4, 8, 10-12, 14-15 ----- 16-20
Y	US 2014/0002658 A1 (LG INNOTEK CO., LTD.) 02 January 2014, abstract, paragraph [0056]	2
Y	EP 0236614 A2 (SI HANDLING SYSTEMS, INC.) 16 September 1987, page 4 lines 20-57, page 5 lines 1-42	3-4
Y -- A	US 2014/0277637 A1 (ZEBRA INNOVATIONS, LLC) 18 September 2014, paragraph [0028]	8, 10-12, 15 ----- 16-20
Y	KR 101915456 B1 (CHOI BYEONG-JU) 06 November 2018, see machine translation	14
A	US 2011/0029182 A1 (HYDE, R et al.) 03 February 2011, entire document	16-20

Further documents are listed in the continuation of Box C.

See patent family annex.

* Special categories of cited documents:	"T" later document published after the international filing date or priority date and not in conflict with the application but cited to understand the principle or theory underlying the invention
"A" document defining the general state of the art which is not considered to be of particular relevance	
"D" document cited by the applicant in the international application	"X" document of particular relevance; the claimed invention cannot be considered novel or cannot be considered to involve an inventive step when the document is taken alone
"E" earlier application or patent but published on or after the international filing date	
"L" document which may throw doubts on priority claim(s) or which is cited to establish the publication date of another citation or other special reason (as specified)	"Y" document of particular relevance; the claimed invention cannot be considered to involve an inventive step when the document is combined with one or more other such documents, such combination being obvious to a person skilled in the art
"O" document referring to an oral disclosure, use, exhibition or other means	
"P" document published prior to the international filing date but later than the priority date claimed	"&" document member of the same patent family

Date of the actual completion of the international search
07 May 2020 (07.05.2020)

Date of mailing of the international search report
27 JUL 2020

Name and mailing address of the ISA/US
Mall Stop PCT, Attn: ISA/US, Commissioner for Patents
P.O. Box 1450, Alexandria, Virginia 22313-1450
Facsimile No. 571-273-8300

Authorized officer
Shane Thomas
Telephone No. PCT Helpdesk: 571-272-4300

INTERNATIONAL SEARCH REPORT

International application No.

PCT/NZ19/50131

Box No. II Observations where certain claims were found unsearchable (Continuation of item 2 of first sheet)

This international search report has not been established in respect of certain claims under Article 17(2)(a) for the following reasons:

- 1. Claims Nos.:
because they relate to subject matter not required to be searched by this Authority, namely:

- 2. Claims Nos.:
because they relate to parts of the international application that do not comply with the prescribed requirements to such an extent that no meaningful international search can be carried out, specifically:

- 3. Claims Nos.: 24-31, 35-37, 40, 44-55, 59, 62, 64, 68-69, 71, 73-76, 80-94
because they are dependent claims and are not drafted in accordance with the second and third sentences of Rule 6.4(a).

Box No. III Observations where unity of invention is lacking (Continuation of item 3 of first sheet)

This International Searching Authority found multiple inventions in this international application, as follows:

*** Continued in Extra Sheet ***

- 1. As all required additional search fees were timely paid by the applicant, this international search report covers all searchable claims.
- 2. As all searchable claims could be searched without effort justifying additional fees, this Authority did not invite payment of additional fees.
- 3. As only some of the required additional search fees were timely paid by the applicant, this international search report covers only those claims for which fees were paid, specifically claims Nos.:

- 4. No required additional search fees were timely paid by the applicant. Consequently, this international search report is restricted to the invention first mentioned in the claims; it is covered by claims Nos.:
Group I: Claims 1-20

Remark on Protest

- The additional search fees were accompanied by the applicant's protest and, where applicable, the payment of a protest fee.
- The additional search fees were accompanied by the applicant's protest but the applicable protest fee was not paid within the time limit specified in the invitation.
- No protest accompanied the payment of additional search fees.

-***-Continued from Box III -***-

This application contains the following inventions or groups of inventions which are not so linked as to form a single general inventive concept under PCT Rule 13.1. In order for all inventions to be examined, the appropriate additional examination fee must be paid.

Group I: Claims 1-20 are directed towards a proximity monitor for monitoring a zone associated with a vehicle using RF receivers of proximate vehicles.

Group II: Claims 21-23, 32-34, and 56-58 are directed towards a proximity monitor utilizing a GPS and RF receiver with proximate transmitter and receiver pairs.

Group III: Claims 38-39 are directed towards a proximity monitor having a front and rear to be aligned with the front and rear of a vehicle in use.

Group IV: Claims 41-43 and 70 are directed towards a passing detector using a GPS receiver and lateral light beams.

Group V: Claims 60-61 and 63 are directed towards a vehicle ordering method to be used between two race vehicles.

Group VI: Claims 65-67, 72 and 77-79 are directed towards systems and methods of determining and communicating penalties.

The inventions listed as Groups I-VI do not relate to a single general inventive concept under PCT Rule 13.1 because, under PCT Rule 13.2, they lack the same or corresponding special technical features for the following reasons:

The special technical features of Group I include at least a proximity monitor for monitoring a zone associated with a vehicle, the proximity monitor comprising: a first radiofrequency "RF" transmitter configured to communicate data with one or more proximate RF receivers of a proximate vehicle in the monitored zone; a first RF receiver configured to acquire signal timing information from signals transmitted by one or more proximate RF transmitters of the proximate vehicle; a processor configured to: generate spacing information as to the spacing between the vehicle and the proximate vehicle; generate an alert signal if the spacing information satisfies an alert criterion, which are not present in Groups II-VI.

The special technical features of Group II include at least a proximity monitor comprising an RF transmitter configured to periodically communicate data with proximate RF receivers; an RF receiver configured to acquire signal timing information from signals transmitted by proximate RF transmitters to develop spacing information as to the spacing between proximate transmitter and receiver pairs; a GPS receiver for obtaining GPS position information; a processor configured to: receive the GPS position information and spacing information, provide this information to the transmitter to communicate with proximate receivers, receive GPS position information and spacing information received by the receiver from proximate transmitters; develop an alert signal if position and spacing information satisfies an alert criterion; determining the positions of vehicles based on GPS signals received by each GPS receiver; determining the spacing between vehicles based on the timing of signals between transceivers; and developing an alert signal if position and spacing information satisfies an alert criterion, which are not present in Groups I and III-VI.

The special technical features of Group III include at least a proximity monitor having a front and rear to be aligned with the front and rear of a vehicle in use, comprising: a proximity detector for detecting the proximity of a second proximity monitor; and a processor for generating an alert signal when a proximity based criteria is satisfied; and a light driven when the alert signal is generated oriented to project light from the rear of the detector, which are not present in Groups I-II and IV-VI.

The special technical features of Group IV include at least a passing detector comprising: a. a housing for mounting to a vehicle; a GPS receiver for obtaining GPS position information; one or more lights generating lateral beams from the sides; one or more detectors which detect the presence of light incident on the sides and generate a detection signal when specified characteristics of incident light are detected; and a processor configured to: i. receive the GPS position information; ii. receive the detection signal; and iii. generate an alert signal, which are not present in Groups I-III and VI.

The special technical features of Group V include at least a vehicle ordering method to be used between two race vehicles wherein each vehicle includes: front-mounted forward facing optical detector; and a rear-mounted and rear-facing optical transmitter, whereby the rear-facing optical transmitter transmits a beam that identifies the race vehicle associated with the optical transmitter, and whereby the leading race vehicle transmits its identifying code to the detector of the trailing race vehicle, which the front-mounted detector detects when it is within a beam transmitted rearwardly by the rear-facing optical transmitter, which are not present in Groups I-IV and VI.

The special technical features of Group VI include at least a race communication system comprising: a plurality of race vehicles, each including an RF transceiver; at least one fixed RF transceiver, located at a known location around the race course; a central computing device; a display device, wherein each RF transceiver is configured to: communicate with other RF transceivers; communicate location information between other RF transceivers; communicate with the central computing device either directly or via at least one other RF transceiver; communicate penalty information between other RF transceivers; a race communication system; a penalty alerting device; and a plurality of penalty detection devices, wherein the plurality of penalty detection devices are configured to detect a rule infraction and communicate via the race communication system to the penalty alerting device, and wherein the penalty alerting device displays a penalty alert to a user; method of enforcing an on-course penalty via a penalty alerting device comprising: detecting a rules infraction; indicating the rules infraction to a user by notification via the penalty alerting device; monitoring the position of the user; determining when the user has satisfied a penalty condition; and indicating the termination of the penalty to a user, which are not present in Groups I-V.

The common technical features shared by Groups I-VI are an RF receiver configured to acquire signal timing information from signals transmitted by proximate RF transmitters to develop spacing information; a GPS receiver for obtaining GPS information; a processor configured to: generate an alert signal if the spacing information satisfies an alert criterion.

-***-Continued Within the Next Supplemental Box-***-

INTERNATIONAL SEARCH REPORT

International application No.

PCT/NZ19/50131

***-Continued from Previous Supplemental Box ***-

However, these common features are previously disclosed by WO 2006/079165 A1 to ALERT SYSTEMS PTY LTD (hereinafter "Alert"). Alert discloses an RF receiver configured to acquire signal timing information from signals transmitted by proximate RF transmitters to develop spacing information (receiving and processing speed data transmitted by radio from other vehicle objects in the vehicles range at the CPU, page 1 lines 4-7, page 3 lines 15-20, page 5 lines 5-10, page 7 lines 30-35, page 8 lines 9-15); a GPS receiver for obtaining GPS information (receiving GPS information, abstract); a processor configured to: generate an alert signal if the spacing information satisfies an alert criterion (the CPU alerting the first vehicle objects are located in its zone, page 3 lines 15-20, page 5 lines 15-25, 6 lines 20-26). While Alert does not specifically disclose an RF receiver which is configured to acquire timing information from signals, it would have been obvious to one of ordinary skill in the art at the time of the invention that the time aspect needed for the speed calculation could be derived from the received signal and that any a receiver common in the art could be configured to acquire said timing.

Since the common technical features are previously disclosed by Alert, these common features are not special and so Groups I-VI lack unity