

A. B. DICK.
 PRINTING MACHINE.
 APPLICATION FILED APR. 12, 1909.

997,245.

Patented July 4, 1911.

2 SHEETS—SHEET 1.

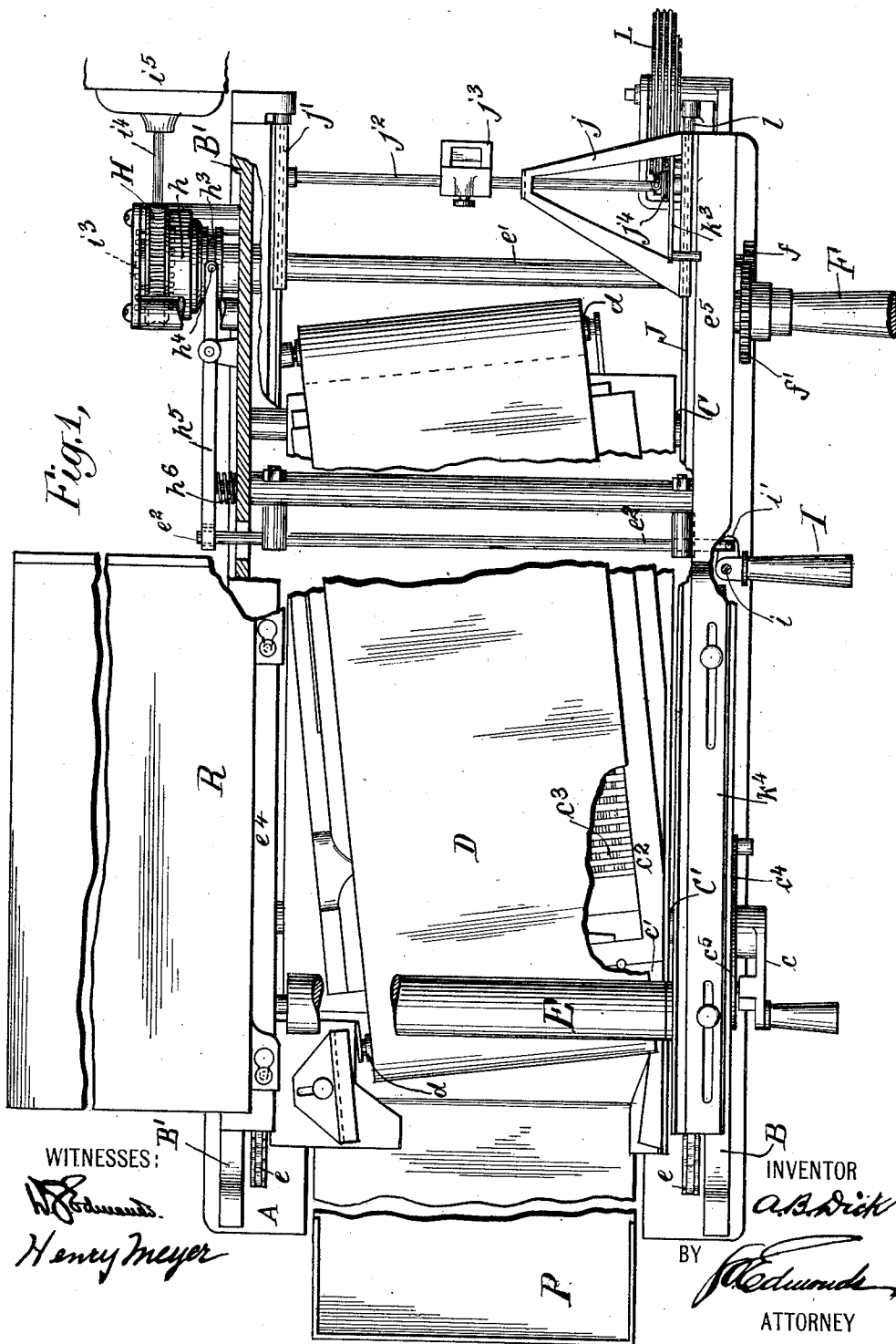

997,245.

Patented July 4, 1911.

2 SHEETS-SHEET 2.

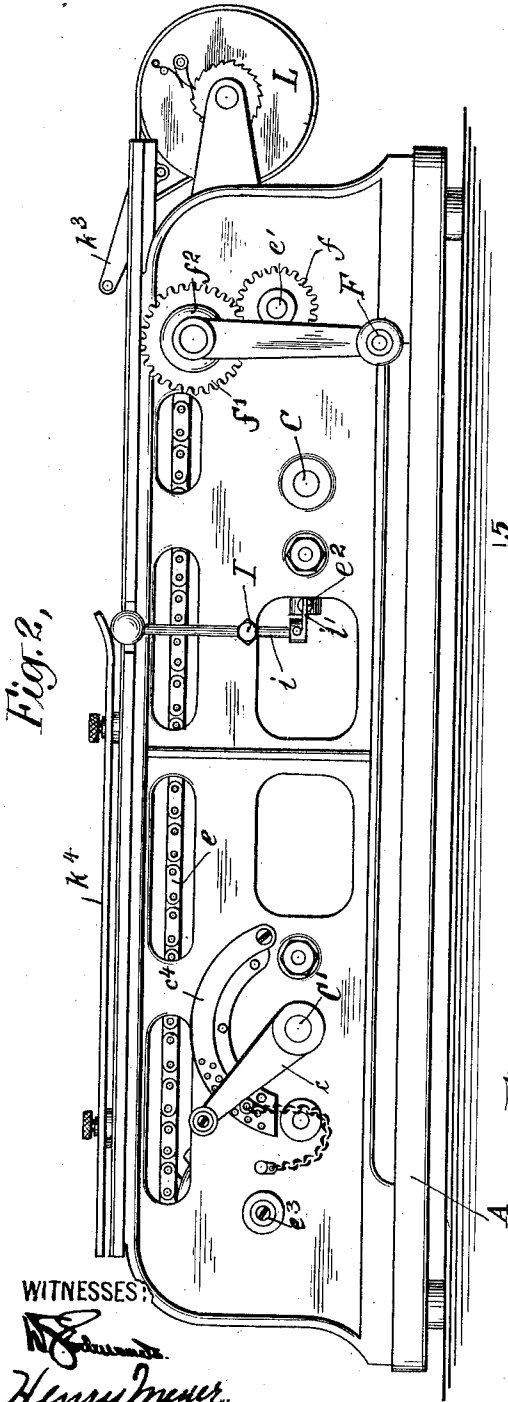

Fig. 2,

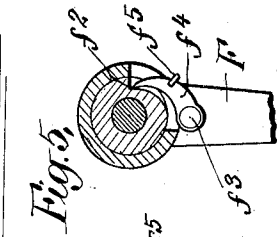

Fig. 5,

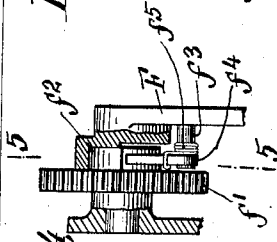

Fig. 4,

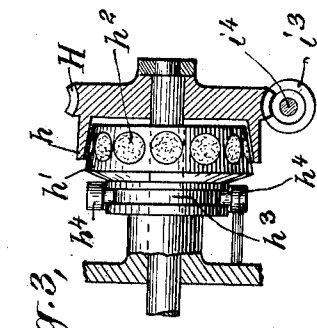

Fig. 3,

WITNESSES:
[Signature]
 Henry Meyer.

INVENTOR
 Albert B. Dick
 BY *[Signature]*
 ATTORNEY

UNITED STATES PATENT OFFICE.

ALBERT B. DICK, OF LAKE FOREST, ILLINOIS, ASSIGNOR TO A. B. DICK COMPANY, OF CHICAGO, ILLINOIS, A CORPORATION OF ILLINOIS.

PRINTING-MACHINE.

997,245.

Specification of Letters Patent.

Patented July 4, 1911.

Original application filed February 9, 1909, Serial No. 476,965. Divided and this application filed April 12, 1909. Serial No. 489,297.

To all whom it may concern:

Be it known that I, ALBERT B. DICK, a citizen of the United States, residing at Lake Forest, in the county of Lake and State of Illinois, have invented certain new and useful Improvements in Printing-Machines, of which the following is a specification.

This invention relates to bed-and-cylinder printing machines of the type in which a platen-roller is mounted upon flexible carriers, arranged for movement so as to carry the platen-roller in one direction over the type and in coaction with the printing faces thereof to effect the printing and then to move the roller in the opposite direction below the type and the support therefor in order to return the roller to its initial position.

The invention is directed particularly to improving the construction of a machine of this type in respects which will adapt the machine for use in offices for making multiple copies of circulars and letters, for which use the machine must be arranged to be run by an unskilled operator at comparatively high speed and preferably to produce copies in imitation of type-written work. For this use the machine is provided with an ink-ribbon extending over the printing faces of the type to supply the ink for printing, instead of using an inking roller of the type commonly employed in printing machines for this purpose.

The improvements to which my invention is particularly directed concern the mechanism by which the machine is operated, this mechanism being such that the machine may be operated manually or by means of power-driven devices and being so arranged that its operation can be conveniently controlled by the operator. To these ends, I provide a suitable motor for driving the machine and also a handle by which the machine may be operated manually and both of these two devices are connected to the parts which they are adapted to actuate by a clutch so that when one of the two actuating devices is in use, the other will remain idle.

In using a machine of this type the operator must stand in a position where he can conveniently perform one or both of the operations of positioning the sheets to be printed upon and removing the printed

55 sheets. It is, therefore, important that the handle for operating the machine be so arranged that it can be conveniently manipulated by the operator while standing in this position. The devices for actuating the machine by power and the clutch therefor, occupy a substantial amount of space and these parts are, therefore, more conveniently disposed upon the side of the machine opposite that at which the operator stands. It is important, however, that the operator be able to control the operation of these devices without difficulty and therefore I arrange, in a position convenient for the operator, a handle or other suitable device by which the operator can control the actuation of the machine by the power-driven devices. 60 65 70

The preferred embodiment of my invention is illustrated in the accompanying drawings in which—

Figure 1 is a plan view of the machine broken away and sectioned in part, Fig. 2 is an elevation of the same, Fig. 3 is a sectional elevation of the clutch for the motor, Fig. 4 is a sectional elevation of a portion of the manual operating device and Fig. 5 is a transverse section on line 5—5 of Fig. 4. 75 80

Referring to these drawings, the machine consists of a base A, on which are mounted side-frames B, B', disposed parallel to each other. Extending between the side-frames and mounted for rotation in bearings therein, are two shafts C, C', connected together, so as to operate in unison, and one provided with a handle *c* for turning the two shafts. These shafts carry eccentrics, upon which is mounted the bed *c'* for supporting the chase *c''* in which the type-form *c'''* is locked in the ordinary manner. An arc-shaped member *c''''* is mounted upon the side-frame B and provided with a number of holes into any one of which a pin *c'''''* may be inserted to facilitate positioning the handle *c*. The mechanism above described permits of raising or lowering the bed *c'* and the form of type thereon, so as to accurately position the same, but it will be understood that any other suitable mechanism for accomplishing this purpose may be provided. An ink-ribbon D overlies the printing faces of the type *c''''*, its ends being wound on spools *d* mounted for rotation in bearings carried by the side-frames of the machine. A pressure-roller E is adapted to coact with the page- 85 90 95 100 105

form of type to effect the printing. This roller E is mounted for rotation in bearings formed in links of two endless carriers *e* here shown as chains, each chain lying adjacent to one of the side-frames. A shaft *e'* is mounted for rotation in bearings formed in the side-frames and carries two sprocket-wheels on which the chains *e* run. At the other end of the machine are two stub-shafts *e''*, upon each of which is rotatably mounted a similar sprocket-wheel for one of the chains *e*. The side-frames B and B' may each be provided with inwardly extending flanges *e⁴* and *e⁵*, and the roller E may have disks upon the ends thereof adapted to travel between these flanges so as to cause the roller E to move in a horizontal plane while passing over the type-form. On one end of the shaft *e'* is a pinion *f* meshing with a gear *f'* adapted to be rotated by a manually operated handle F. Between the handle F and the gear *f'* is a clutch which permits the gear *f'* to rotate independently of handle F when the machine is being driven by power.

Referring to Figs. 4 and 5, it will be seen that the gear *f'* has a hub *f²* on the side thereof adapted to be received within a similarly shaped recess formed in the end of the handle F. On the side of handle F is a pin *f³* forming a pivot for a pawl *f⁴*, the end of which is pressed by a spring *f⁵* in a direction to carry it through a cut-away portion in the handle F and into a notch in the hub *f²*, as shown in Fig. 5. It will be seen that handle F, when rotated in a counter-clockwise direction as seen in Fig. 5, will cause rotation of hub *f²* and gear *f'*, thereby operating the shafts *e'* and carriers *e*, but that gear *f'* and hub *f²* may be rotated in this direction without causing rotation of handle F.

On the other side of the machine, the shaft *e'* is extended through its bearing in the side-frame B' and a worm-gear H is loosely mounted on this end of shaft *e'*. Gear H has a flange *h* on the side thereof, the inner surface of which is conical-shaped. Splined on shaft *e'* between the gear H and the side-frame B' is a clutch-member *h'* having a conical-shaped surface corresponding to the interior surface of flange *h* and provided with pads *h²* of such material as will give a good frictional engagement between the clutch-member *h'* and the flange *h*. The clutch-member *h'* has a circumferential groove *h³* adapted to receive pins on the ends of bifurcated arms *h⁴* of a lever *h⁵* pivotally mounted upon the side-frame B'. The clutch-member *h'* is normally held away from the gear H in the position shown in Fig. 3, by a spring *h⁶* arranged between the side-frame B' and the lever *h⁵*; but the clutch-member may be moved into engagement with the gear H by means of a handle

I pivotally mounted upon the side-frame B at the other side of the machine, in a position convenient for the operator. The shaft *i* upon which handle I is mounted has a crank *i'* to which is pivotally connected one end of a connecting rod *e²*, the other end of which is pivotally connected to the lever *h⁵*. The gear H meshes with a worm *i³* on the shaft *i⁴* of an electric motor *i⁵*. It will be seen that when the motor *i⁵* is in operation, it may be caused to actuate the machine by merely turning handle I in a direction to move the clutch-member *h'* against the tension of spring *h⁶* into engagement with the gear H. Thus by manipulating the handle I, the machine may be operated by the motor continuously or intermittently, and in the latter case by movements of any extent desired, and by releasing the handle I the motor is thrown out of driving relation and the machine may be operated as is desired by the handle F.

The machine as thus constructed may be provided with means for delivering the printed sheets, if desired. A convenient form of such delivery device consists of a hook-shaped member *j³* mounted upon shaft *j²* extending between the side-frames of the machine. As the machine is operated this hook-shaped member moves over the page-form of type, engages the rear edge of a printed sheet lying thereon and pushes this sheet ahead of it into a delivery-tray P. Preferably, mechanism is provided for rocking the shaft *j²* in suitable bearings immediately after the end of hook *j³* engages a sheet so as to raise the end of the hook above the plane of the printing-faces of the type. For this purpose I have shown an arm *k³* on shaft *j²* adapted to engage a cam *k⁴* adjustable lengthwise upon the upper edge of the side-frame B. Until the end of arm *k³* is engaged and depressed by cam *k⁴*, it is held in a raised position by a spring *j⁴* acting upon the shaft *j²*. The ends of the shaft *j²* are received in bearings formed in guides *j*, *j'* which are arranged to slide back and forth on ways J formed on the upper edges of the side-frames B, B' of the machine. These guides and the rod and hook carried thereby are moved to deliver a sheet, that is to the left in Fig. 1, by means of a projection on one of the chains *e*, and as that projection is carried downwardly around one of the sprockets at the left of the machine, it releases the guide *j*. While this pin on the chain and the pressure-roller E are returning to initial positions beneath the page-form of type, the delivery device is retracted to its initial position. For this purpose I have provided a cord, attached to the guide *j* at one end and having its other end wound upon a drum L within which is a spiral spring such that as soon as the delivery device is released by the pin on the chain,

the spring will turn the drum L in a direction to retract the delivery device to its initial position where its movement is arrested by a buffer l.

5 With a machine constructed in this manner the operator stands at the side of the machine close to the side-frame B and with his left hand takes sheets successively from a feed-table R and places them in printing
10 position. If he desires to operate the machine manually he can, while standing in this position, operate the handle F with his right hand quite conveniently. During such operation the motor \mathcal{M}^5 is disconnected from
15 the machine by the clutch \mathcal{H}' . If now it is desired to operate the machine from power, the operator releases the handle F, closes the circuit of the motor \mathcal{M}^5 and then with his right hand manipulates the handle I for
20 controlling the clutch \mathcal{H}' , as may be necessary. By turning the handle I, the machine may be operated to any desired extent, and the operator can stop the movement of the machine instantly whenever such stopping
25 becomes desirable. Thus the operator may turn the handle I sufficiently to cause the pressure-roller E to make one complete forward and return movement each time and in the intervals of rest the operator may
30 place sheets in printing position, but if the operator is more expert in positioning the sheets, the movement of the roller E may be continuous, until such time when a sheet does not fall readily into printing position,

at which time the operator may, by turning 35 handle I, bring the machine to rest very quickly.

Having now described my invention, what I claim as new therein and desire to secure by Letters Patent of the United States, is 40 as follows:

A printing-machine having a bed, a form of type thereon, an ink-ribbon coacting with the printing faces of the type, a rotatable 45 pressure-roller, means for moving the pressure-roller in one direction in coaction with the type to effect the printing of an impression and in the other direction on the other side of the bed and type-form to return it to initial position, a motor on one side of 50 the machine adapted to move said roller, a clutch for connecting the motor in driving relation to the roller or disconnecting it therefrom, an operating device on the other side of the machine for controlling said 55 clutch, a manually operated handle on the same side of the machine as said operating device and adjacent to said device, and a clutch between said handle and the roller for connecting the handle in driving rela- 60 tion to the roller or disconnecting it therefrom, substantially as set forth.

This specification signed and witnessed this 8th day of April, 1909.

ALBERT B. DICK.

Witnesses:

D. S. EDMONDS,
HENRY MEYER.