

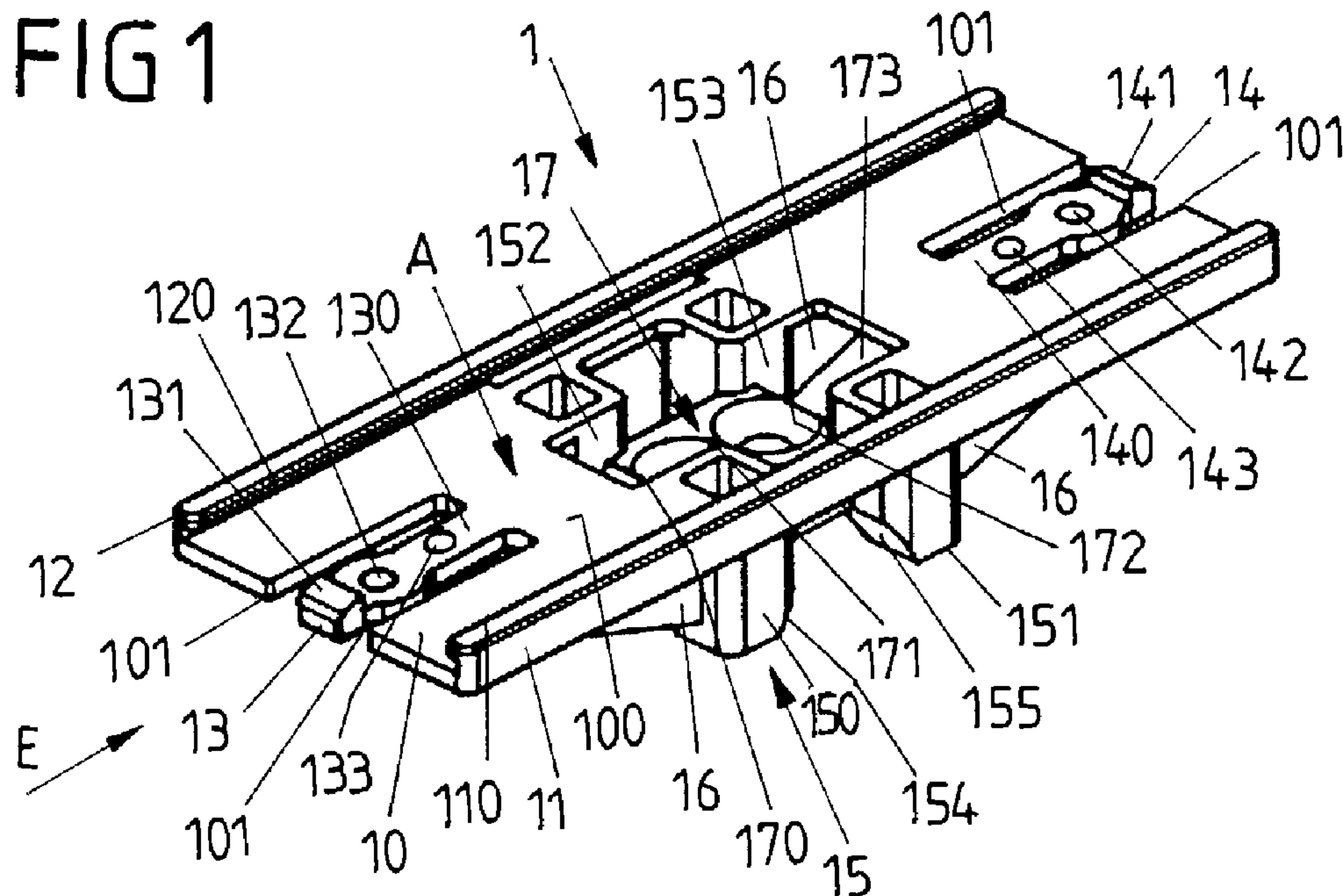

(86) Date de dépôt PCT/PCT Filing Date: 2016/02/19  
 (87) Date publication PCT/PCT Publication Date: 2016/09/15  
 (85) Entrée phase nationale/National Entry: 2017/08/30  
 (86) N° demande PCT/PCT Application No.: EP 2016/053524  
 (87) N° publication PCT/PCT Publication No.: 2016/142149  
 (30) Priorité/Priority: 2015/03/06 (DE10 2015 103 292.9)

(51) Cl.Int./Int.Cl. *G09F 7/18* (2006.01)  
 (71) Demandeur/Applicant:  
 PHOENIX CONTACT GMBH & CO. KG, DE  
 (72) Inventeurs/Inventors:  
 PROBACH, NICOLE, DE;  
 POLKER, THOMAS, DE;  
 OSTER, PATRICK, DE;  
 KLAGES, KILIAN, DE  
 (74) Agent: BORDEN LADNER GERVAIS LLP

(54) Titre : PORTE-PLAQUE DESTINE A MAINTENIR UNE PLAQUE D'IDENTIFICATION  
 (54) Title: PLATE HOLDER FOR HOLDING A LICENSE PLATE



(57) **Abrégé/Abstract:**

A plate holder (1) for holding a license plate (2) comprises a holder base (10) and two guide rails (11, 12), arranged on the holder base (10) and extending in parallel to each other, a license plate (2) being slidable between said rails along an insertion direction (E) to arrange the plate on the plate holder (1). The license plate (2) is held between the guide rails (11, 12) in a position arranged on the plate holder (1). In addition, at least one resilient snap-in element (13, 14) is provided and is arranged on the holder base (10). Said snap-in element can be elastically deformed when the license plate (2) is arranged on the plate holder (1) and locks the license plate (2) in position on the holder base (10) against the movement along the insertion direction (E) when it is in the position arranged on the plate holder (1). The invention provides a plate holder which allows a simple placement of a registration plate on the plate holder and also a simple, possibly tool-free removal of the registration plate from the plate holder.

**ABSTRACT**

A plate holder (1) for holding a license plate (2) comprises a holder base (10) and two guide rails (11, 12), arranged on the holder base (10) and extending in parallel to each other, a license plate (2) being slidable between said rails along an insertion direction (E) to arrange the plate on the plate holder (1). The license plate (2) is held between the guide rails (11, 12) in a position arranged on the plate holder (1). In addition, at least one resilient snap-in element (13, 14) is provided and is arranged on the holder base (10). Said snap-in element can be elastically deformed when the license plate (2) is arranged on the plate holder (1) and locks the license plate (2) in position on the holder base (10) against the movement along the insertion direction (E) when it is in the position arranged on the plate holder (1). The invention provides a plate holder which allows a simple placement of a registration plate on the plate holder and also a simple, possibly tool-free removal of the registration plate from the plate holder.

## PLATE HOLDER FOR HOLDING A LICENSE PLATE

[0001] The invention relates to a plate carrier for carrying a license plate according to the preamble of claim 1.

[0002] A plate carrier of this kind comprises a carrier body and two guide rails that are arranged on the carrier body and extend so as to be mutually parallel, and between which a license plate can be pushed in an insertion direction in order to be arranged on the plate carrier. The guide rails extend in parallel with the insertion direction and are designed to receive the license plate therebetween such that the license plate is held between the guide rails when arranged on the plate carrier.

[0003] A plate carrier of this kind is used for example for identifying leads such as tubes, cables, pipes or the like. A license plate may in this case have lettering or another marking so that, by means of the license plate, a lead can be identified for example, or other information that is important for the operation of the lead or of an installation connected to the lead, for example, can be displayed on the lead.

[0004] In principle, a plate carrier can also be attached to other objects, for example in the industrial field.

[0005] In the case of plate carriers of this kind, there is a need for the license plate to be able to be attached to the plate carrier as simply as possible and to be held in a secure and reliable manner in a position arranged on the plate carrier. It is also desirable, in this case, for a license plate to be able to be released from the plate carrier again, as far as possible without using tools.

[0006] In the case of a plate carrier known from DE 197 43 405 A1, a license plate can be inserted between rails and is held between the rails when in position. By raising the license plate, the license plate can be released from the plate carrier, over a stop elevation.

[0007] In the case of a plate carrier known from DE 20 2011 000 569 U1, a plate is fastened to a carrier body by means of rivets.

[0008] The object of the present invention is that of providing a plate carrier that allows simple placement of a license plate in position on the plate carrier, and also allows simple release of the license plate from the plate carrier, as far as possible without using tools.

[0009] This object is achieved by subject matter having the features of claim 1.

[0010] According thereto, the plate carrier comprises at least one resilient latching element that is arranged on the carrier body and that can be deformed elastically when the license plate is being arranged on the plate carrier, and that secures the license plate on the carrier body against movement in the insertion direction when said license plate is arranged on the plate carrier.

[0011] Providing the resilient latching element makes it possible for a license plate, which may optionally be inherently rigid, to be placed in position on the plate carrier in a simple manner, and also for the license plate to be released from the plate carrier without using tools. In order to place a license plate in position on the plate carrier, the license plate is pushed between the guide rails. In this case, the license plate strikes the at least one latching element and forces said element aside in a resilient manner so that the license plate can be pushed over the latching element and into the plate carrier. When the license plate has achieved its specified fit on the carrier body, the latching element snaps back into the initial position thereof and comes into latching engagement for example with an edge of the license plate, so that the latching element secures the license plate on the carrier body against movement in the insertion direction.

[0012] A license plate can thus be placed in position on the plate carrier in a simple manner, by forcing aside the latching element, without the license plate needing to be deformed for this purpose. The fact that the latching element snaps into latching engagement with the license plate and thus captively secures said license plate on the plate carrier when the license plate has reached its specified position on the plate carrier, provides for a reliable hold of the license plate on the plate carrier.

[0013] In order to release the license plate from the plate carrier, the at least one latching element can be deformed such that the license plate is released so as to move in the insertion direction and can thus be pushed out of the plate carrier. The resilient deformation of the latching element can be carried out without using tools, by a user grasping the latching

element by hand for example and pressing said element out of engagement with the license plate. It is thus not necessary to deform the license plate in order to release said plate from the plate carrier, and therefore rigid license plates that cannot easily be deformed can also be arranged on the plate carrier and released from the plate carrier again in a simple manner.

[0014] In an advantageous embodiment, the plate carrier comprises two latching elements that are arranged on the carrier body so as to be offset from one another in the insertion direction. In the position arranged on the plate carrier, the latching elements receive the license plate therebetween for example, in that a first latching element comes to rest against a first edge of the license plate that extends transversely to the guide rails, and a second latching element comes to rest against a second edge of the license plate that extends transversely to the guide rails, and the license plate is thus secured on the carrier body in a form-fitting manner in the insertion direction.

[0015] The carrier body comprises a support surface for example, which surface extends in a support plane and is used as a support for the license plate. By being pushed into the guide rails, the license plate is pushed onto the support surface such that the license plate rests in a planar manner on the support surface when arranged on the plate carrier.

[0016] In a specific embodiment, the at least one latching element is formed by a resilient web that is connected to the support surface. The web can be cut out of the support surface by means of slit-shaped openings for example, so as to result in a latching element in the manner of a snap-in tongue that can be moved towards the support surface in a resilient manner. A latching projection is preferably arranged on the at least one latching element, which projection rises above the support surface and thus provides a stop for the license plate. When the license plate is placed in position on the plate carrier, the license plate strikes the latching projection of the latching element and thus forces the latching element aside. When the license plate has reached its specified position on the plate carrier, the latching projection snaps into engagement with an edge of the license plate for example, such that the edge comes into contact with the latching projection and thus secures the license plate on the plate carrier against movement in the insertion direction.

[0017] The license plate is secured in a latching manner on the plate carrier by means of the latching projection, such that the license plate is prevented from being pushed out of its fit between the guide rails. In addition, the at least one latching element can comprise an elevation that projects from the support surface and that is designed to come into contact, when the license plate is arranged on the plate carrier, with an underside of the license plate that faces the support surface. The elevation can be rounded in a lenticular manner for example, so that the license plate can strike the elevation in a simple manner when being pushed into the plate carrier. When the license plate has been placed in position on the plate carrier, the elevation presses against the license plate from below and thus presses said license plate into contact with the guide rails, perpendicularly to the support surface, such that the license plate is held on the guide rails so as not to clatter and so as to have zero clearance.

[0018] Furthermore, a fastening point for fastening the license plate to the carrier body can be arranged on the at least one latching element. The fastening point can be designed for attaching a rivet or screw joint for example, so that, by means of the fastening point, the license plate can be additionally fastened to the plate carrier, by the latching connection provided by the at least one latching element, when said license plate has been placed in position on the plate carrier.

[0019] The plate carrier is used to arrange a license plate on a lead or on another object. For this purpose, the plate carrier can comprise a positioning apparatus for example, by means of which the plate carrier can be advantageously placed in position on a lead. A lead of this kind can be designed for example as a pipeline, as an electrical, pneumatic, hydraulic or another cable, or as another elongate lead. In this context, a lead is to be understood as any elongate element. For example, it can also be possible to place the plate carrier in position on a railing or on another elongate carrier by means of the positioning apparatus.

[0020] In one embodiment, the positioning apparatus comprises at least two positioning elements that project from the carrier body and the ends of which remote from the carrier body can be placed in position on the lead. The positioning elements can be peg-shaped for example, and are spaced apart from one another such that the lead comes to rest between the positioning elements when the plate carrier is placed in position.

[0021] In order to provide a precise hold together with favorable contact on the lead in this case, the positioning elements can for example each comprise a chamfer at the ends thereof remote from the carrier body, which chamfer comes into contact with the lead during positioning. The positioning elements are thus beveled on at least one edge in the region of the ends, such that each positioning element can come into contact with the lead by means of the chamfer, and a precise fit of the plate carrier on the lead is thus provided.

[0022] In a specific embodiment, the positioning apparatus can comprise four peg-shaped positioning elements for example, which elements extend so as to be mutually parallel and project from the carrier body. By means of the four peg-shaped positioning elements, the plate carrier can be placed in position on the lead for example in two different positions that are rotated by 90° with respect to one another, such that an elongate license plate can be arranged on the lead for example in parallel with an extension direction of the lead or transversely to the extension direction of the lead.

[0023] For this purpose, the positioning elements are preferably arranged relative to one another such that they together span a rectangle, preferably a square, when viewed in a cutting plane in parallel with the support surface. The positioning elements are thus arranged at corners of an, imaginary, rectangle. In this way, a lead can be received between the positioning elements in two different positions, in each case two positioning elements coming to rest on one side of the lead and the two other positioning elements coming to rest opposite, on the other side of the lead (reference is made to a center plane that is spanned by the longitudinal extension direction of the lead and a positioning direction in which the plate carrier is to be placed in position on the lead by means of the positioning apparatus).

[0024] If the positioning apparatus comprises four positioning elements that allow positioning on a lead in two different positions that are rotated by 90° with respect to one another, the positioning elements preferably each comprise two chamfers that are offset from one another such that a first chamfer comes into contact with the lead in a first position of the lead and, in contrast, a second chamfer comes into contact with the lead in a second position of the lead that is rotated by 90°. For this purpose, the chamfers are arranged at different edges, angled by 90° relative to one another, in the region of the end of each positioning element, such that the positioning element is beveled at two edges that extend at right angles to one another.

[0025] In order to secure the plate carrier on a lead, a fastening apparatus can be provided, which apparatus for example allows attachment of a fastening element in the form of a cable tie or the like. The fastening apparatus comprises at least one web, around which the fastening element, for example a cable tie, can be laid, in order to connect the plate carrier to the lead. In this case, the at least one web preferably comprises a chamfer and is thus beveled on at least one edge. The chamfer forms a contact surface for the fastening element so that the fastening element, for example a cable tie, can be laid around the web in a favorable manner and so as to be in low-wear contact with the chamfer.

[0026] The concept on which the invention is based will be described in greater detail in the following, with reference to the embodiments shown in the drawings, in which:

[0027] Fig. 1 is a perspective view of a plate carrier;

[0028] Fig. 2 is a perspective view of the plate carrier comprising a license plate arranged thereon;

[0029] Fig. 3 is a perspective view of the plate carrier comprising a license plate arranged thereon, the license plate being additionally connected to the plate carrier by means of rivets;

[0030] Fig. 4A is a cross section along the line A-A according to Fig. 2;

[0031] Fig. 4B is a cross section along the line B-B according to Fig. 2;

[0032] Fig. 5A is a perspective view of the plate carrier when the license plate is being placed in position;

[0033] Fig. 5B is a cross section along the line B-B according to Fig. 5A;

[0034] Fig. 6A is a side view of the plate carrier on a lead; and

[0035] Fig. 6B is a cross section of the arrangement according to Fig. 6A, in accordance with the cutting line B-B according to Fig. 2.

[0036] Fig. 1 is a perspective view of a plate carrier 1 that is used for receiving a license plate 2 (see Fig. 2 and 3). The plate carrier 1 can be arranged on a lead 3 (see Fig. 6A and

6B) in order to thus attach the license plate 2 to the lead 3, for example in order to label the lead 3 or to mark the lead 3 with information that is important for the lead 3 or for an installation connected to the lead 3.

[0037] It should be noted at this point that a plate carrier 1 of the type described here can in principle also be attached to other objects, for example installation housings or the like. In this respect, the plate carrier 1 is not limited to fastening a license plate 2 to a lead 3.

[0038] The plate carrier 1 comprises a carrier body 10, on the sides of which guide rails 11, 12 are arranged. The carrier body 10 comprises a support surface 100 on which a license plate 2 rests in a planar manner when said plate is placed in position on the plate carrier 1, such that the support surface 100 provides defined contact for the license plate 2.

[0039] The support surface 100 extends in a support plane A. The guide rails 11, 12 project from the support surface 100 perpendicularly to the support plane A and extend so as to be mutually parallel such that the support surface 100 is laterally delimited by the guide rails 11, 12.

[0040] The guide rails 11, 12 each comprise a guide bar 110, 120 on an edge remote from the support surface 100, which guide bars define a form-fitting engagement for a license plate 2. A license plate 2 can be pushed in between the guide rails 11, 12 in an insertion direction E such that, in a position in which the license plate 2 is arranged on the plate carrier 1, the license plate 2 comes to rest between the guide rails 11, 12 and is held on the plate carrier 1, perpendicularly to the support surface 100, by means of the guide bars 110, 120 (see Fig. 2 and 3).

[0041] Two latching elements 13, 14 are arranged on the support surface 100, which elements are cut out from the support surface 100 in the manner of snap-in tongues by means of slit-shaped openings 101. The latching elements 13, 14 are each connected to the support surface 100 by means of a web 130, 140, and extend in the insertion direction E in the manner of tongues. In this case, the latching elements 13, 14 are resilient perpendicularly to the support surface 100 on account of the webs 130, 140 thereof.

[0042] Each latching element 13, 14 has a latching projection 131, 141. In the position arranged on the plate carrier 1, the latching projections 131, 141 receive the license plate 2

therebetween such that the license plate 2 is secured on the plate carrier 1 against movement in the insertion direction E (see Fig. 2). In this case, each latching projection 131, 141 comes into contact with an edge 23, 24 of the license plate 2 that extends transversely to the guide rails 11, 12, such that the license plate 2 is thereby held between the latching projections 131, 141 in a form-fitting manner.

[0043] In addition to the latching projection 131, 141, a fastening position 132, 142 is arranged on the latching elements 13, 14 in each case which makes it possible for a rivet joint 18 to be attached, as shown in Fig. 3. The license plate 2 can be additionally secured to the carrier body 10 by means of a rivet joint 18 of this kind.

[0044] Furthermore, as shown schematically in Fig. 1, an elevation 133, 143 is arranged on each latching element 13, 14, which elevation projects from the support plane A provided by the support surface 100. When the license plate 2 is placed in position on the plate carrier 1, the elevations 133, 143 of the latching elements 13, 14 are in contact with the underside 25 (see Fig. 5A) of the license plate 2 from below, such that the license plate 2 presses against the guide bars 110, 120 of the guide rails 11, 12 perpendicularly from below by means of the elevations 133, 143, and in this way an initial stress is applied to the license plate 2 which secures the license plate 2 on the plate carrier 1 so as not to clatter and so as to have zero clearance.

[0045] For the purpose of positioning, the license plate 2 is placed in position on the plate carrier 1, as shown in Fig. 5A and 5B, and the lateral edges 21, 22 thereof are pushed between the guide rails 11, 12 from one side in the insertion direction E. The front transverse edge 24 of the license plate 2 thus comes into contact with the latching projection 31 of the latching element 13 on the side of the plate carrier 1 from which the license plate 2 is pushed into the plate carrier 1. As a result, the license plate 2 strikes the latching projection 131 and forces the latching element 13 aside such that the license plate 2 can be pushed between the guide rails 11, 12, over the latching projection 131.

[0046] When the license plate 2 has been completely pushed into the plate carrier 1, the latching projection 131 of the latching element 13 comes into contact, in a latching manner, with the rear transverse edge 23, such that the transverse edges 23, 24 of the license plate 2 are received between the latching projections 131, 141 of the latching elements 13, 14, and

the lateral edges 21, 22 of said license plate are additionally held between the lateral guide rails 11, 12.

[0047] In order to release the license plate 2 from the plate carrier 1, one of the latching elements 13, 14 can be resiliently bent so as to disengage from the associated transverse edge 23, 24 of the license plate 2, such that the license plate 2 can be pushed out of engagement with the guide rails 11, 12, over the relevant latching element 13, 14. This is possible without using tools and in particular without deforming the license plate 2.

[0048] The plate carrier 1 comprises a positioning apparatus 15 that is formed by four peg-shaped positioning elements 150-153. The positioning elements 150-153 project on a side of the carrier body 10 remote from the support surface 100 and form a seat for a lead 3 on the plate carrier 1.

[0049] The positioning apparatus 15 comprises four positioning elements 150-153 in total, which elements extend so as to be mutually parallel and are arranged at corners of an (imaginary) square when viewed in a cross-sectional plane in parallel with the support plane A.

[0050] The positioning elements 150-153 make it possible for the plate carrier 1 to be placed in position on a lead 3 in two different positions that are rotated by 90° with respect to one another. The support surface 100 of the plate carrier 1 can thus be placed in position transversely on a lead 3, as shown in Fig. 6A and 6B. In this case, the positioning elements 150, 152 come to rest on one side of the lead 3 and the positioning elements 151, 153 come to rest on the other side of the lead 3, such that the lead is received between two pairs of positioning elements, 150, 152 and 151, 153.

[0051] Alternatively, the support surface 100 of the plate carrier 1 can be arranged in the longitudinal extension direction of the lead 3. In this case, the plate carrier is thus rotated by 90° with respect to the position according to Fig. 6A and 6B, such that the positioning elements 150, 151 come to rest on one side of the lead 3 and the positioning elements 152, 153 come to rest on the other side of the lead 3.

[0052] In order to achieve a favorable fit of the lead 3 on the positioning elements 150-153, each positioning element 150-153 comprises two chamfers 154-157 in the form of bevels.

The inside edges of the end of each positioning element 150-153 are beveled, such that a chamfer 154-157 of each positioning element 150-153 is in contact with the lead 3 when the plate carrier 1 is placed in position on a lead 3 (see Fig. 6A and 6B).

[0053] Each positioning element 150-153 is supported on the carrier body 10 by means of a rib 16, so as to form a dimensionally stable unit. The plate carrier 1 additionally comprises a fastening apparatus 17 that is formed by webs 170-172 that extend between the positioning elements 150-153. There are openings 175 between the webs 170-172. In addition, openings 173, 174 are formed between the positioning elements 150-153 and the carrier body 10.

[0054] A fastening element 4, for example in the form of a cable tie, can be laid around the webs 170-172, as shown in Fig. 6A and 6B. The webs 170-172 each have chamfers on the edges thereof, so as to provide favorable contact of the fastening element 4 on in particular the outer webs 170, 172. The beveled design of the webs 170-172 results in low-wear contact of the fastening element 4 on the webs 170-172.

[0055] When fastened, the fastening element 4 extends around the lead 3 and one or more of the webs 170-172, as shown in Fig. 6A and 6B. The plate carrier 1 is thus secured on the lead 3 by means of the fastening element 4.

[0056] The carrier body 10 is advantageously produced as a plastics molded part, for example by means of plastics injection molding.

[0057] The concept on which the invention is based is not limited to the embodiments described above, but instead can in principle also be implemented in entirely different manners.

[0058] In principle, it is sufficient to provide just one latching element on the plate carrier, such that a license plate can be pushed into the plate carrier just from one side.

**List of reference signs**

1	plate carrier
10	carrier body
100	support surface
101	slits
11, 12	guide rail
110, 120	guide bar
13, 14	latching element
130, 140	web
131, 141	detent
132, 142	fastening point
133, 143	elevation
15	positioning apparatus
150-153	positioning element (peg)
154-157	chamfer
16	rib
17	fastening apparatus
170-172	web
173-175	opening
176	chamfer
18	rivet joint
2	license plate
21-24	edge
25	underside
3	lead
4	fastening element
A	support plane
E	insertion direction

**CLAIMS:**

1. Plate carrier (1) for carrying a license plate (2), comprising
  - a carrier body (10) and
  - two guide rails (11, 12) that are arranged on the carrier body (10) and extend so as to be mutually parallel, and between which a license plate (2) can be pushed in an insertion direction (E) in order to be arranged on the plate carrier (1), the license plate (2) being held between the guide rails (11, 12) when arranged on the plate carrier (1),  
characterized by  
at least one resilient latching element (13, 14) that is arranged on the carrier body (10) and that can be deformed elastically when the license plate (2) is being arranged on the plate carrier (1), and that secures the license plate (2) on the carrier body (10) against movement in the insertion direction (E) when said license plate is arranged on the plate carrier (1).
2. Plate carrier (1) according to claim 1, characterized by two latching elements (13, 14) that are arranged on the carrier body (10) so as to be offset from one another in the insertion direction (E).
3. Plate carrier (1) according to claim 2, characterized in that the two latching elements (13, 14) receive the license plate (2) therebetween when said license plate is arranged on the plate carrier (1).
4. Plate carrier (1) according to any of claims 1 to 3, characterized in that the carrier body (10) comprises a support surface (100) that extends in a support plane (A) and on which the license plate (2) rests when arranged on the plate carrier (1).
5. Plate carrier (1) according to claim 4, characterized in that the at least one latching element (13, 14) is connected to the support surface (100) of the carrier body (10) by means of a web (130).
6. Plate carrier (1) according to either claim 4 or claim 5, characterized in that the at least one latching element (13, 14) comprises a latching projection (131, 141) that projects

from the support surface (100) transversely to the support plane (A) and is designed such that an edge (23, 24) thereof comes into contact with the license plate (2) when the license plate (2) is arranged on the plate carrier (1).

7. Plate carrier (1) according to any of claims 4 to 6, characterized in that the at least one latching element (13, 14) comprises an elevation (133, 143) that projects from the support surface (100) and that is designed to come into contact, when the license plate (2) is arranged on the plate carrier (1), with an underside (25) of the license plate (2) that faces the support surface (100).

8. Plate carrier (1) according to any of the preceding claims, characterized in that the at least one latching element (13, 14) comprises a fastening point (132, 142) for fastening the license plate (2) to the carrier body (10).

9. Plate carrier (1) according to any of the preceding claims, characterized by a positioning apparatus (15), by means of which the plate carrier (1) can be placed in position on a lead (3), the positioning apparatus (15) comprising at least two positioning elements (150-153) that project from the carrier body (10) and the ends of which remote from the carrier body (10) can be placed in position on the lead (3).

10. Plate carrier (1) according to claim 9, characterized in that the positioning elements (150-153) each comprise a chamfer (154-157) at the ends thereof remote from the carrier body (10), which chamfer can be brought into contact with the lead (3) during positioning on the lead (3).

11. Plate carrier (1) according to either claim 9 or claim 10, characterized in that the positioning apparatus (15) comprises four peg-shaped positioning elements (150-153) that extend so as to be mutually parallel and that project from the carrier body (10).

12. Plate carrier (1) according to claim 11, characterized in that the positioning elements (150-153) define two positions, rotated by 90° with respect to one another, in which the plate carrier (1) can be placed in position on the lead (3).

13. Plate carrier (1) according to either claim 11 or claim 12, characterized in that the positioning elements (150-153) are arranged relative to one another on the carrier body (10) such that the positioning elements (150-153) span a rectangle, preferably a square.

14. Plate carrier (1) according to any of claims 11 to 13, characterized in that the positioning elements (150-153) each comprise two mutually offset chamfers (154-157) at the ends thereof remote from the carrier body (10) for placing the plate carrier (1) in position on the lead (3) in different positions.

15. Plate carrier (1) according to any of the preceding claims, characterized by a fastening apparatus (17) comprising at least one web (170-172), around which a fastening element (4) for fastening the plate carrier (1) to a lead (2) can be laid, the at least one web (170-172) comprising at least one chamfer (176) as a contact surface for the fastening element (4).

FIG 1

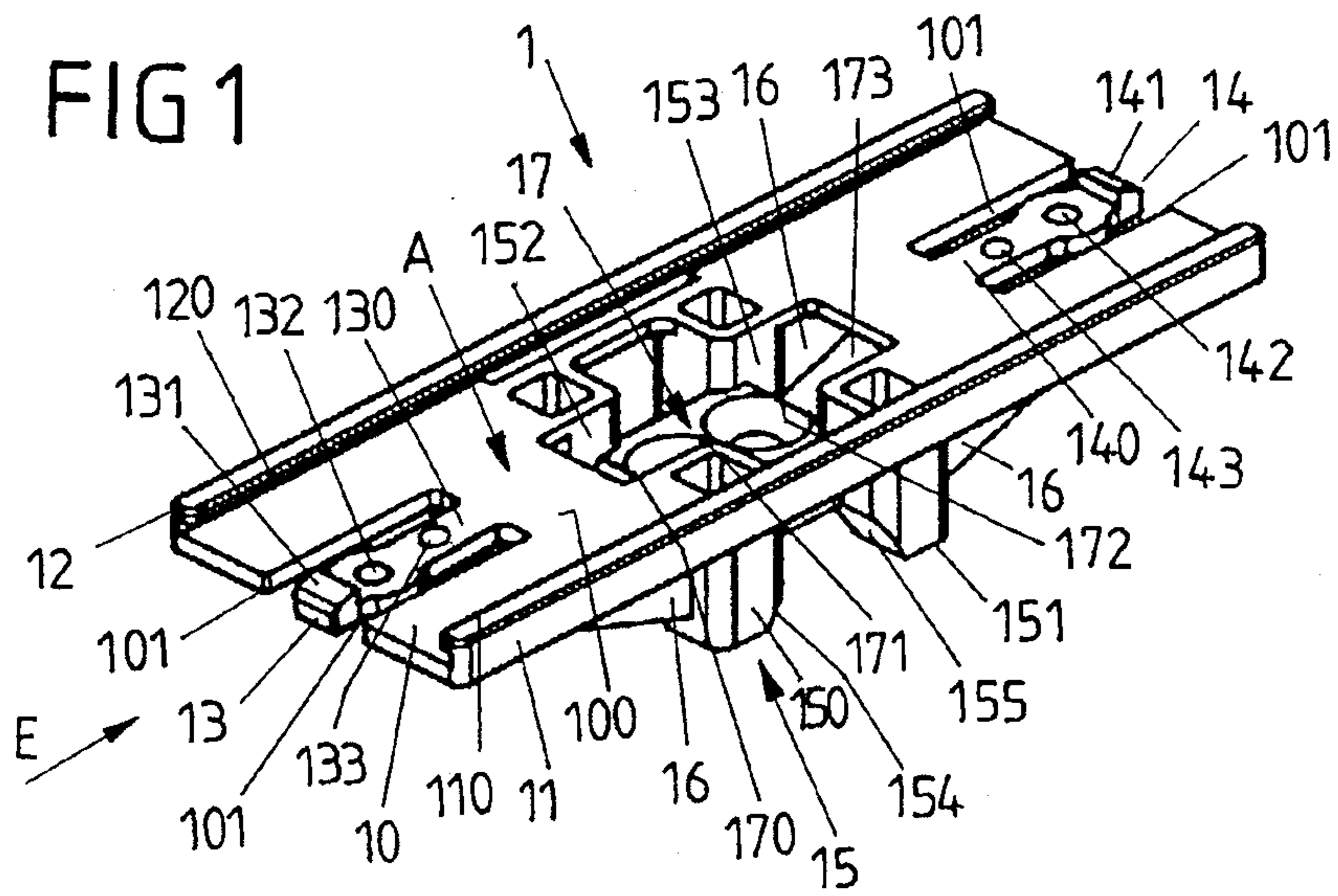

FIG 2

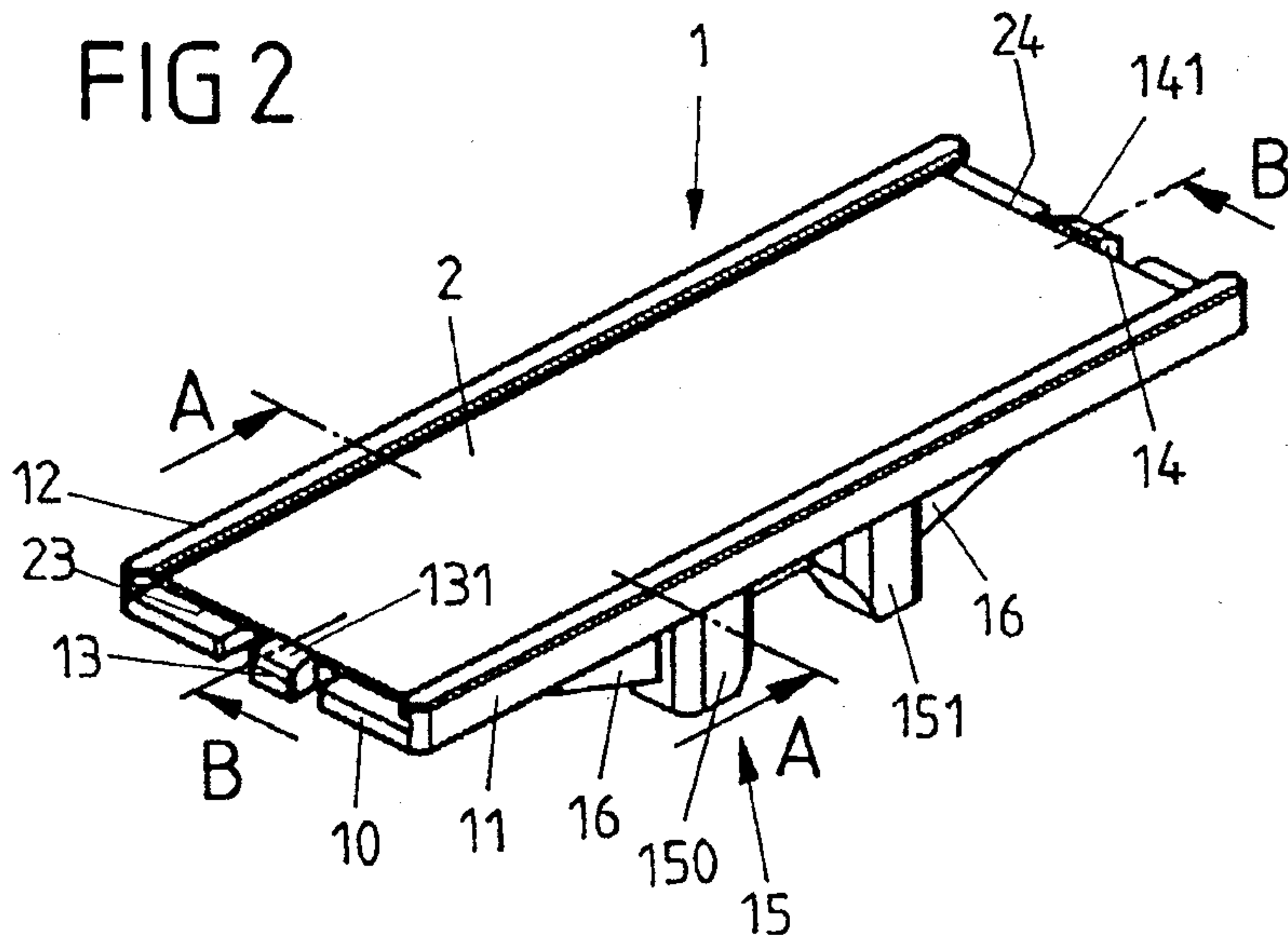

FIG 3

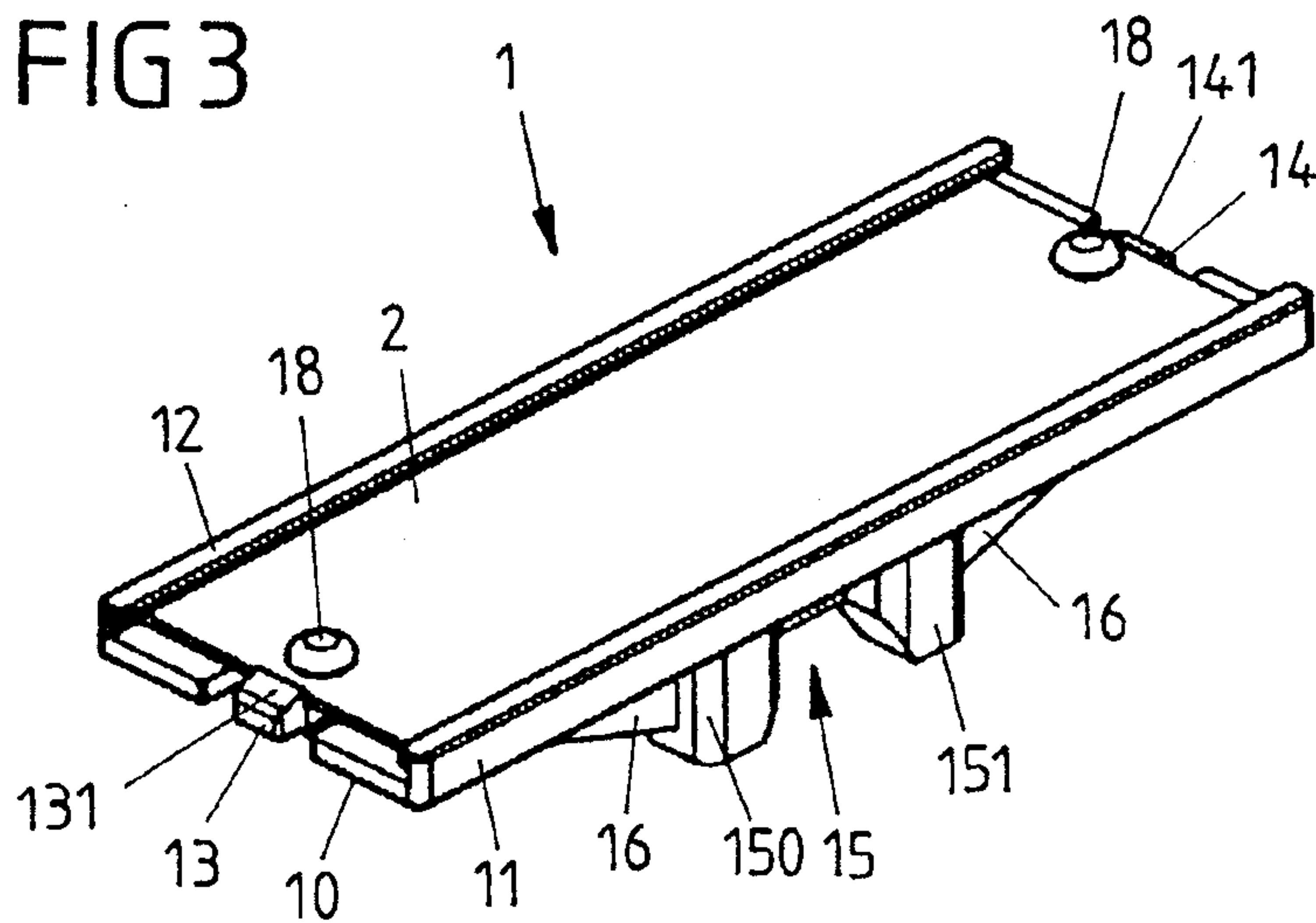

FIG 4B  
(B-B)

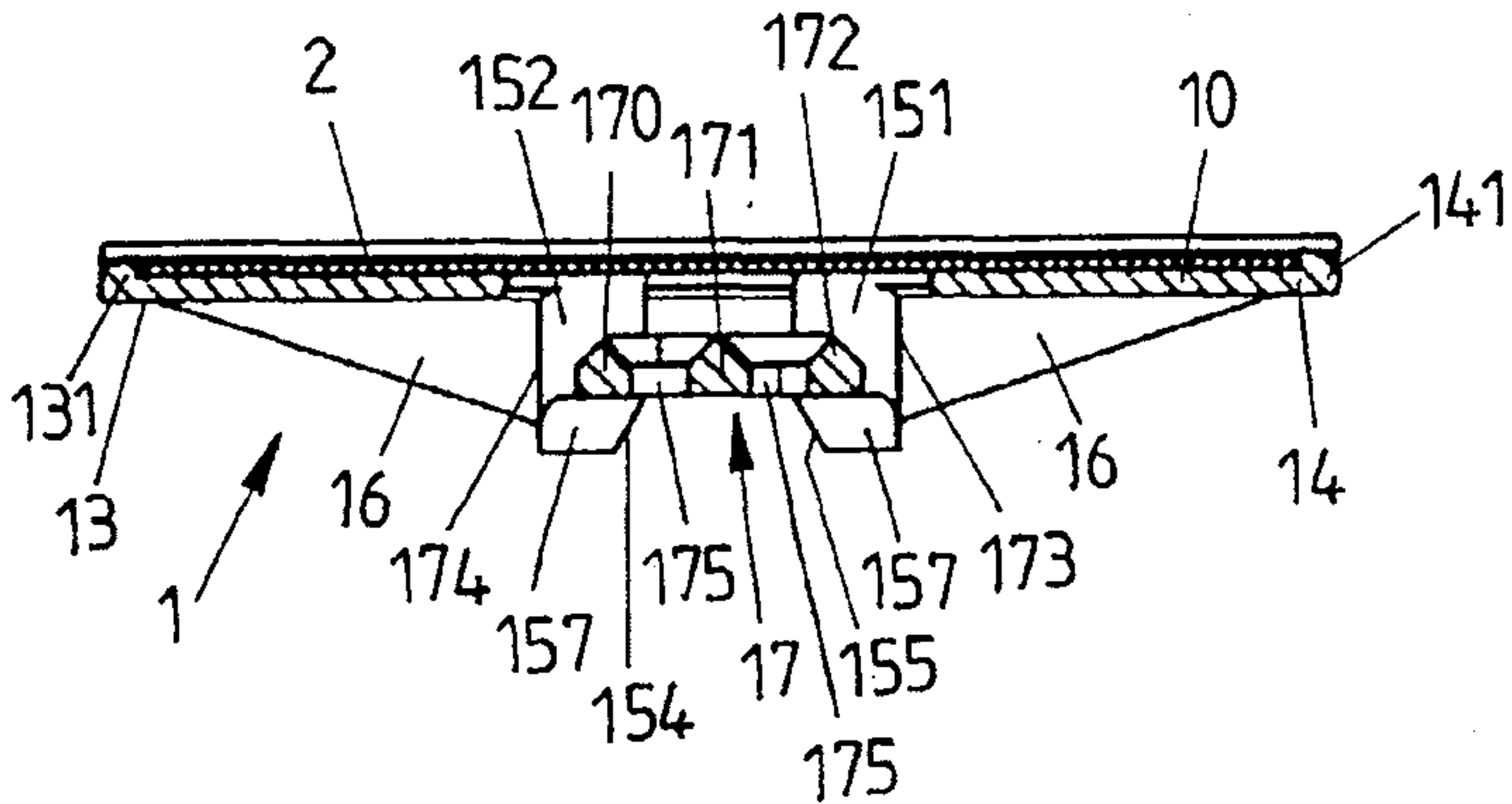

FIG 4A  
(A-A)

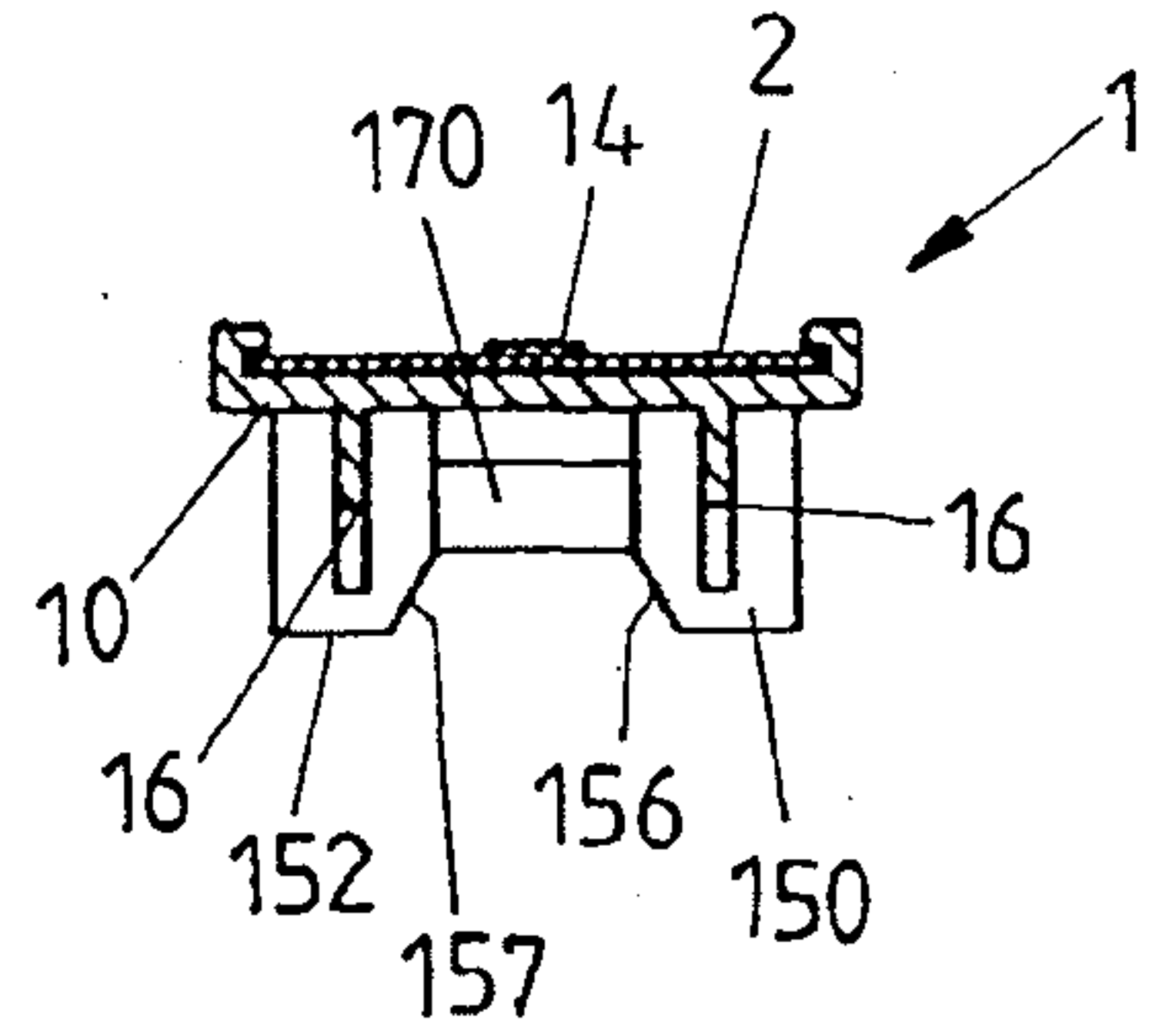

FIG 5A

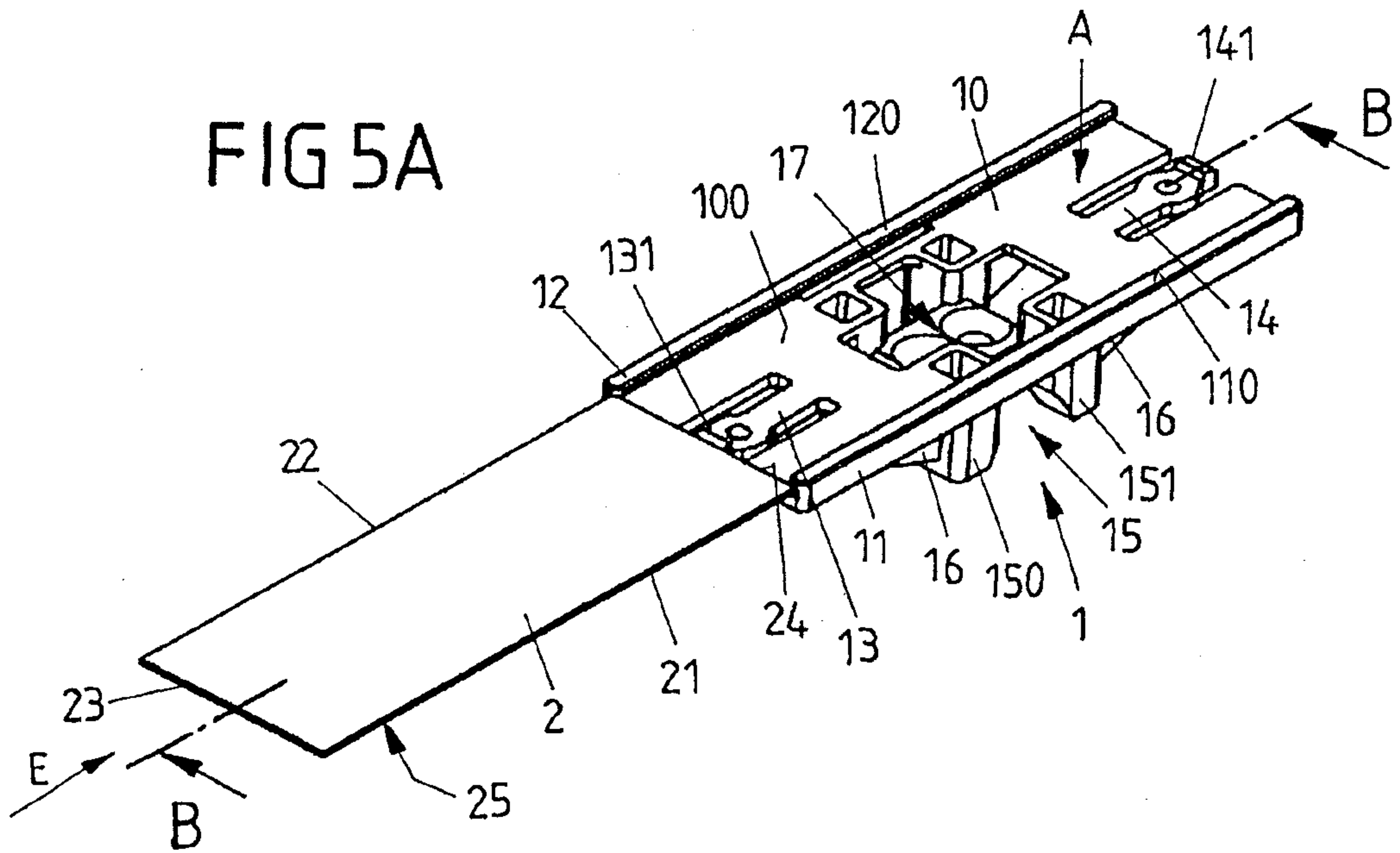

FIG 5B  
(B-B)

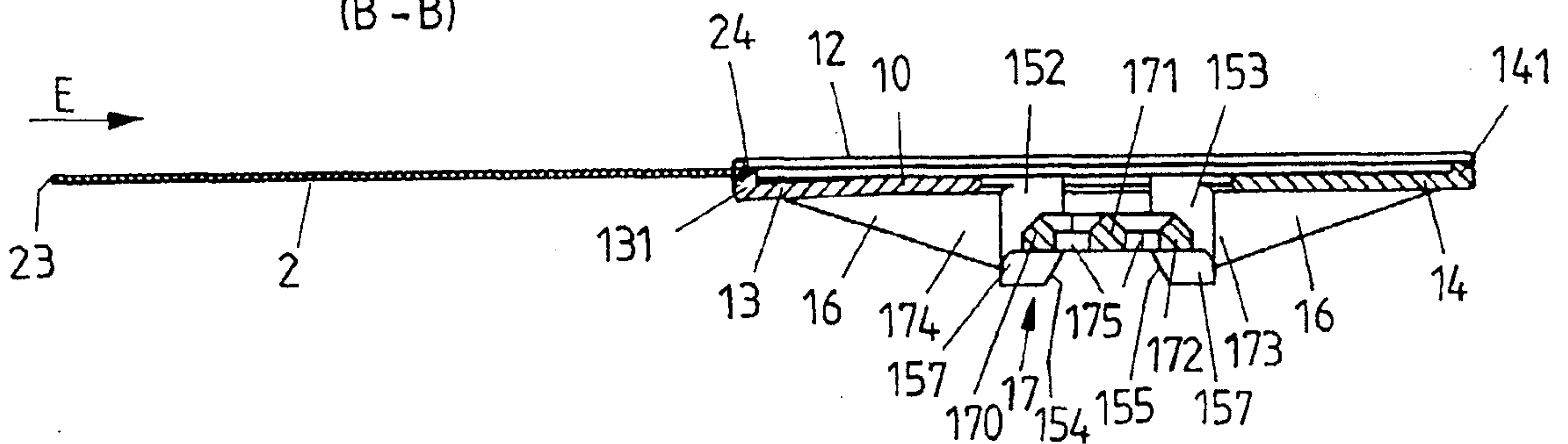

FIG 6A

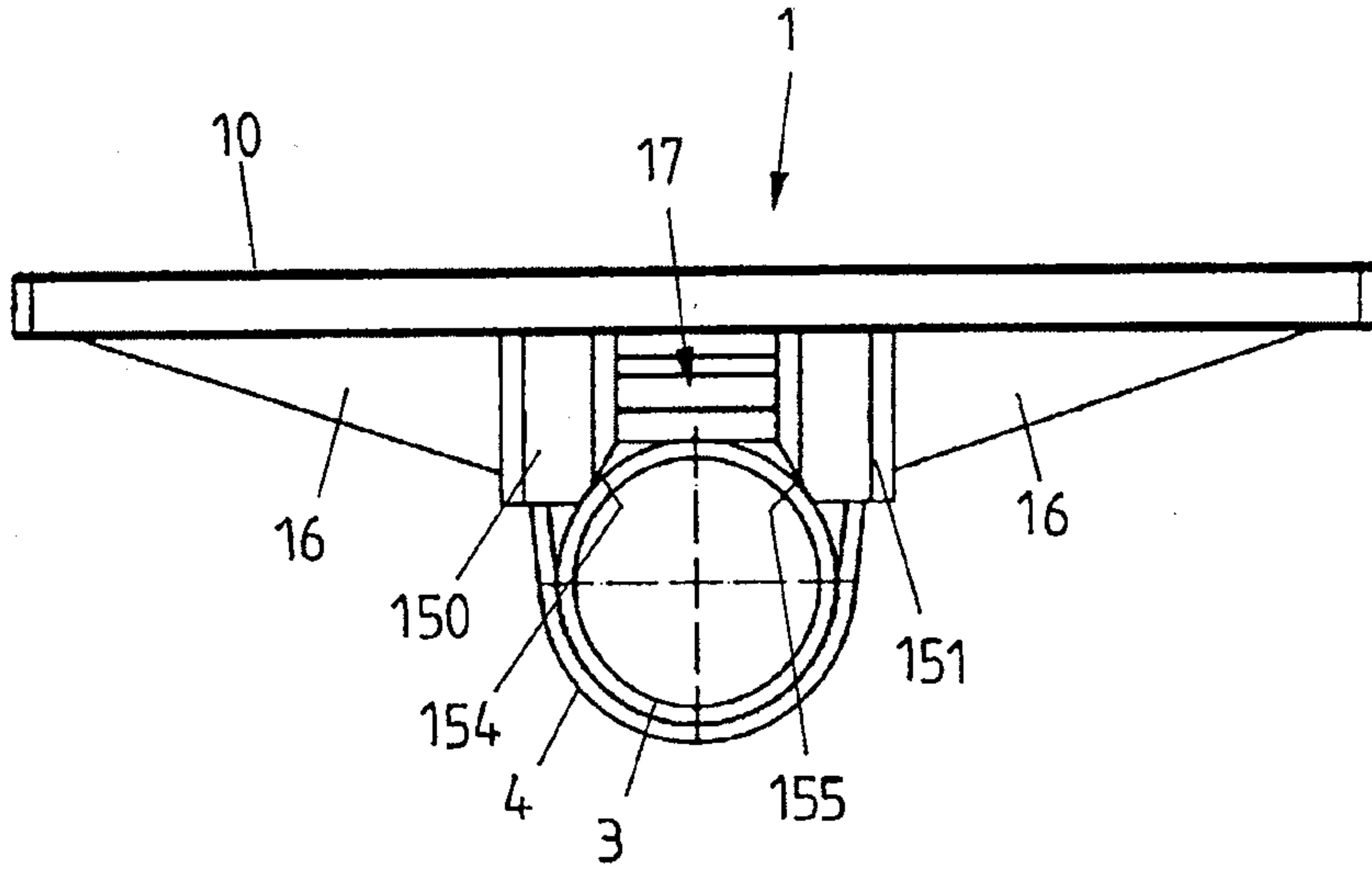
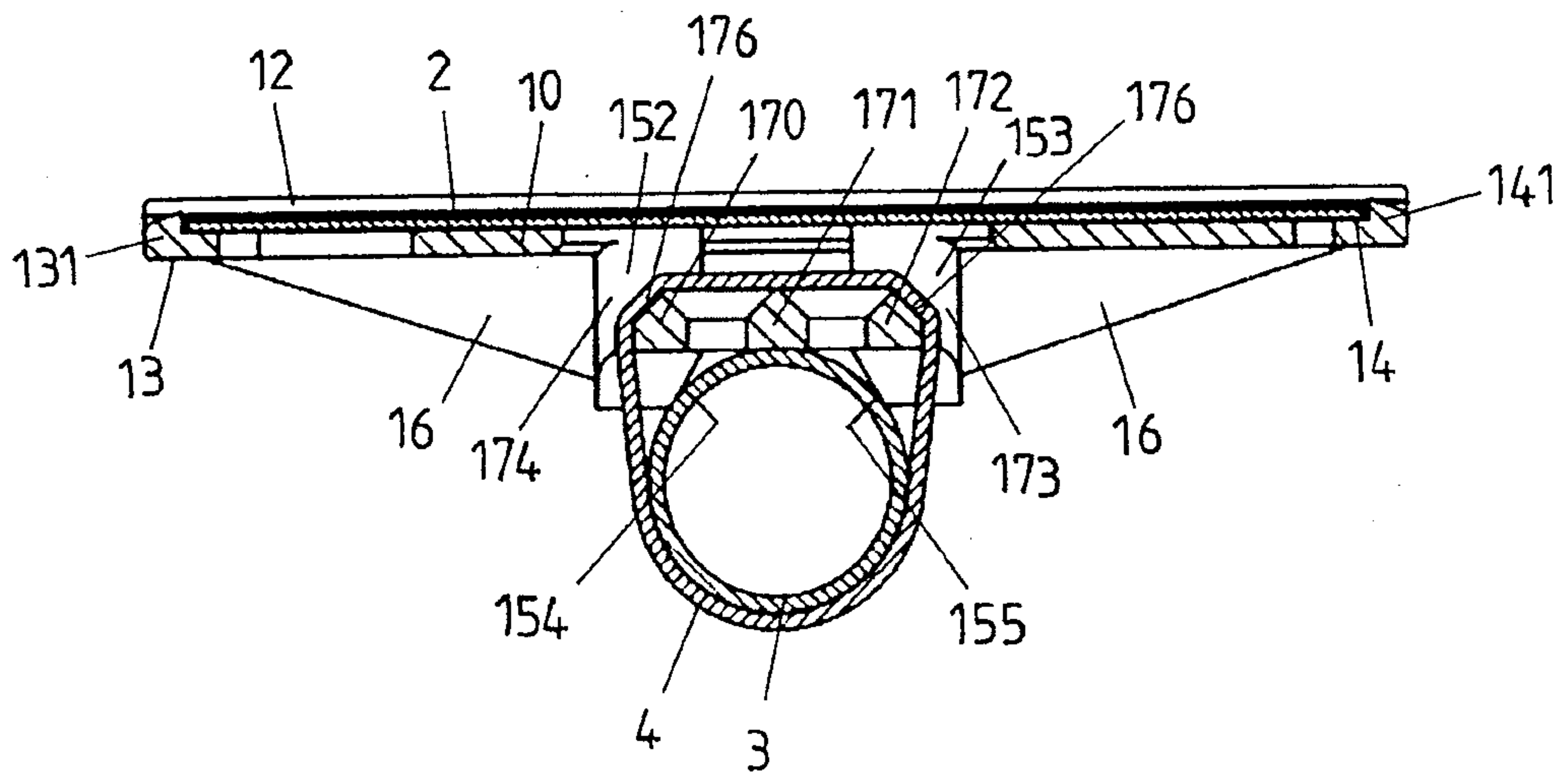

FIG 6B



# FIG 1

