

[72] Inventor **Troy Scarborough**
 201 South May Ave., Brooksville, Fla.
 33512

[21] Appl. No. **785,537**

[22] Filed **Dec. 20, 1968**

[45] Patented **Oct. 5, 1971**

3,037,470 6/1962 Watson et al. 111/52

3,202,119 8/1965 Loomans 111/85

3,333,645 8/1967 Gustafson 172/413 X

Primary Examiner—Robert E. Pulfrey
Assistant Examiner—Stephen C. Pellegrino
Attorneys—Clarence A. O'Brien and Harvey B. Jacobson

[54] **PLANTING MACHINE**
 13 Claims, 10 Drawing Figs.

[52] U.S. Cl. 111/61,
 111/85, 172/458, 172/322, 172/554

[51] Int. Cl. **A01c 5/06,**
 A01b 63/00

[50] Field of Search 111/52, 53,
 54, 55, 56, 57, 58, 59, 60, 61, 62, 63, 64, 65, 85,
 10; 172/413, 776, 452, 322, 554, 71, 244, 397

[56] **References Cited**
UNITED STATES PATENTS

2,921,640	1/1960	Roppel	172/452 X
3,090,447	5/1963	Hotchkiss	172/458 X
Re.3,464	5/1869	Randall	111/10
1,425,867	8/1922	Kubicek	111/61
2,579,988	12/1951	Walburn	111/85 X

ABSTRACT: A planting machine or seeder including three pivotally interconnected frames, a main frame supporting a power driven coultter, a level control frame supporting ground-engaging traveling wheels, and a trailing frame supporting a ground-driven cover roller. Power means are engaged between the main frame and the level control frame for varying the angular relationship therebetween and hence the effective depth to which the coultter disks on the main frame plow, the trailing frame automatically angling relative to the level control frame so as to maintain a constant ground-engaging orientation of the cover roller. A seed-dispensing unit is mounted on the main frame and driven directly from the plow or coultter roller, and lock means is provided between the level control frame and the trailing frame for selectively locking the cover roller in an elevated position relative to the ground-engaging wheels, the plow roller also being positionable in an elevated position whereby only the traveling wheels contact the ground for highway travel of the machine.

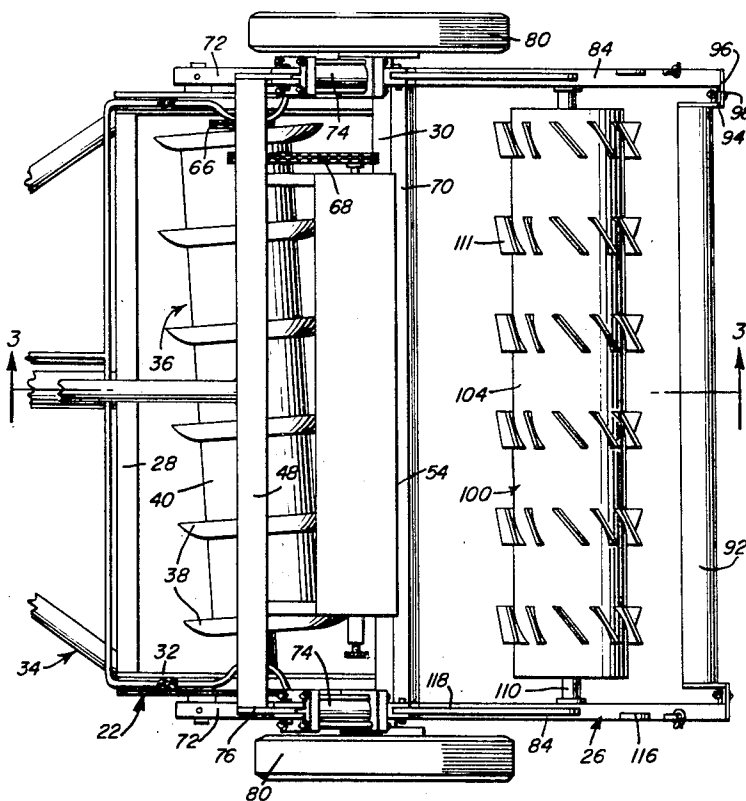
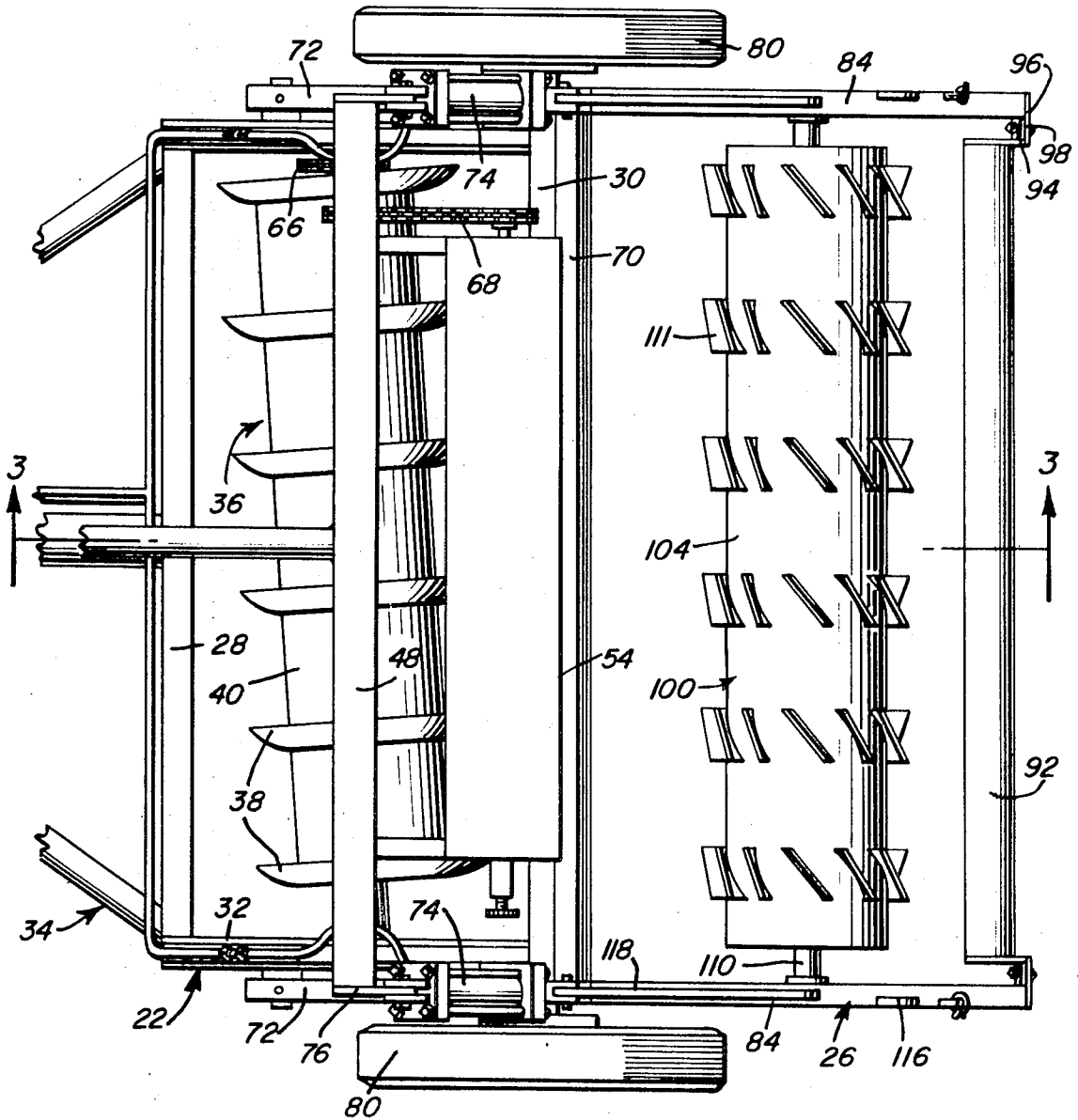

Fig. 1



Troy Scarborough

INVENTOR.

BY *Abner A. O'Brien*
and Harvey E. Jacobson
Attorneys

Fig. 2

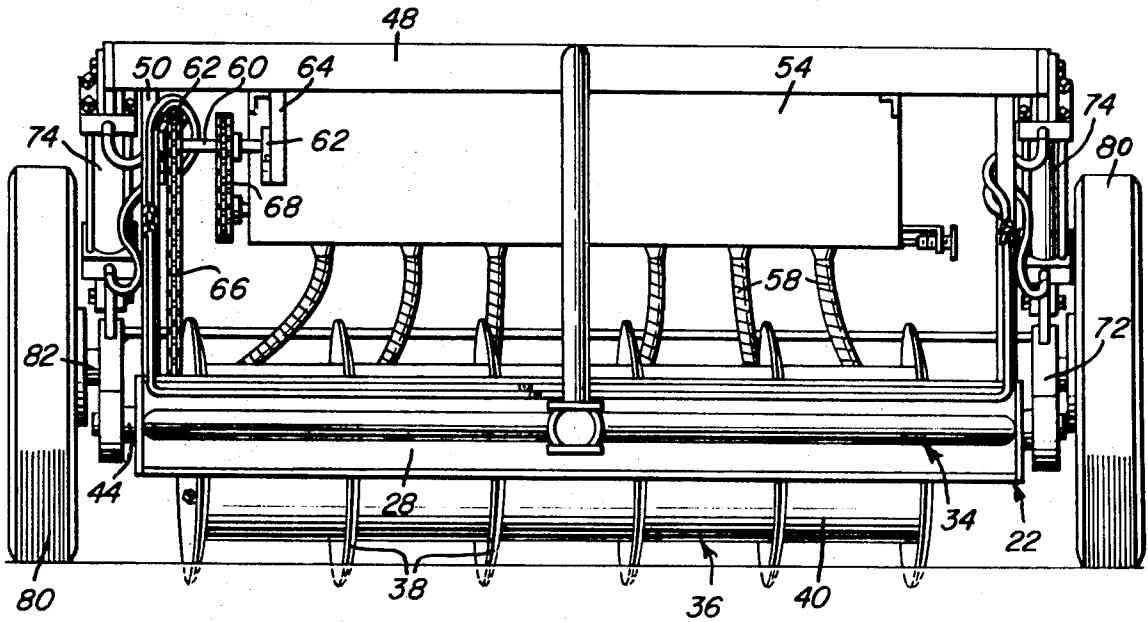
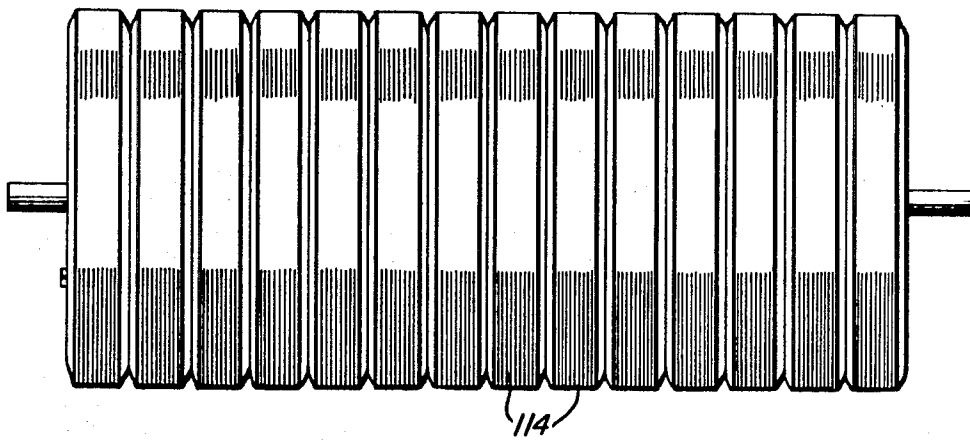

Fig. 5



Troy Scarborough

INVENTOR.

BY *Abunce A. O'Brien*
and Harvey B. Jacobson
Attorneys

Fig. 3

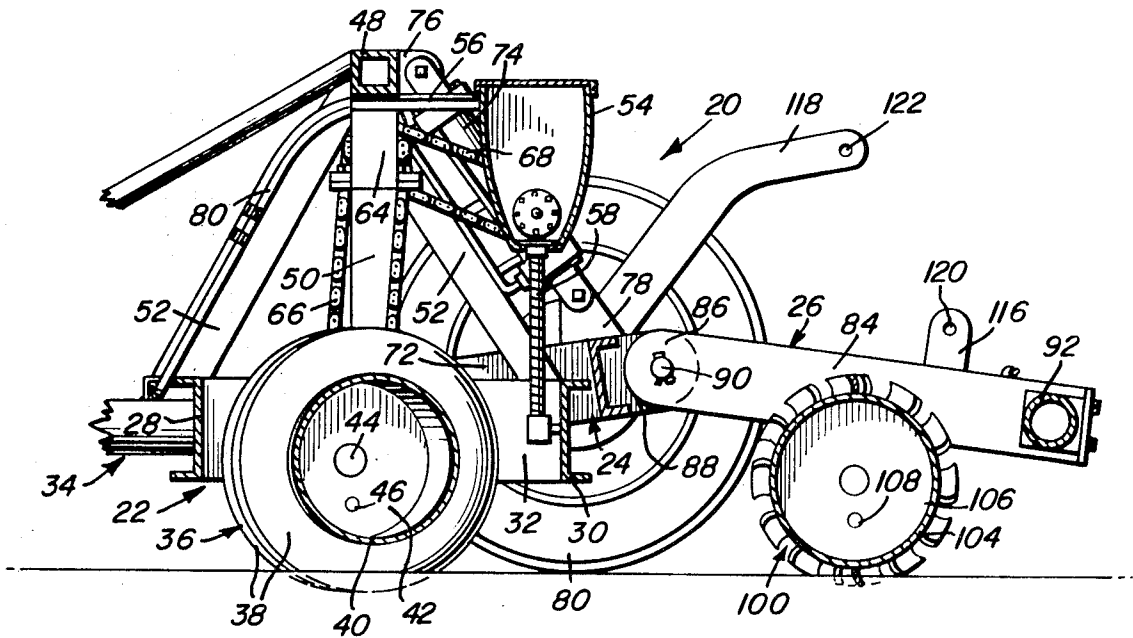

Fig. 4

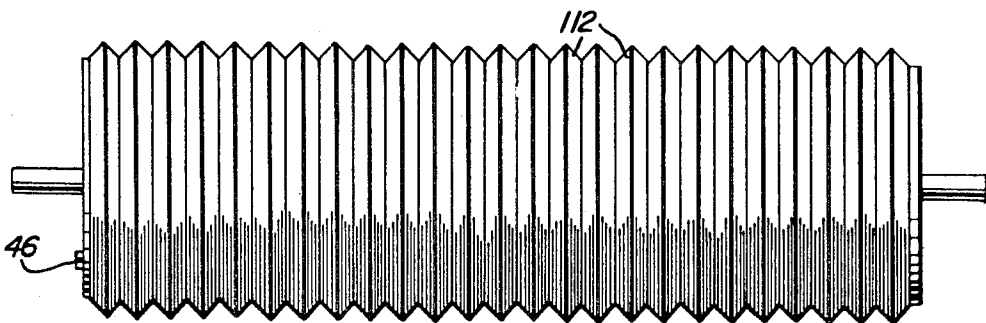
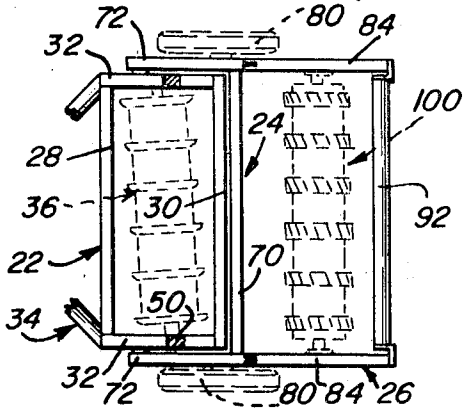

Fig. 10



Troy Scarborough
INVENTOR.

BY *Alvanice A. O'Brien*
and Harvey B. Jacobson
Attorneys

Fig. 6

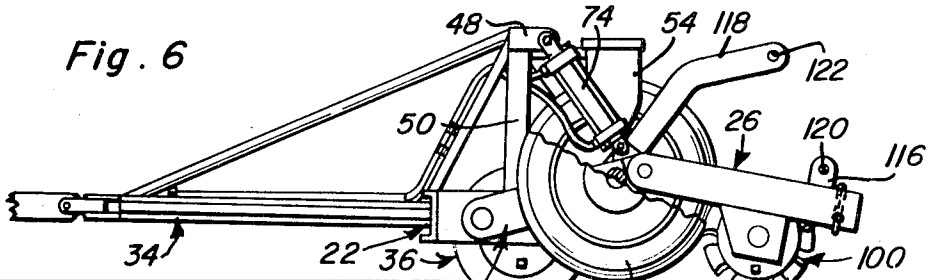

Fig. 7

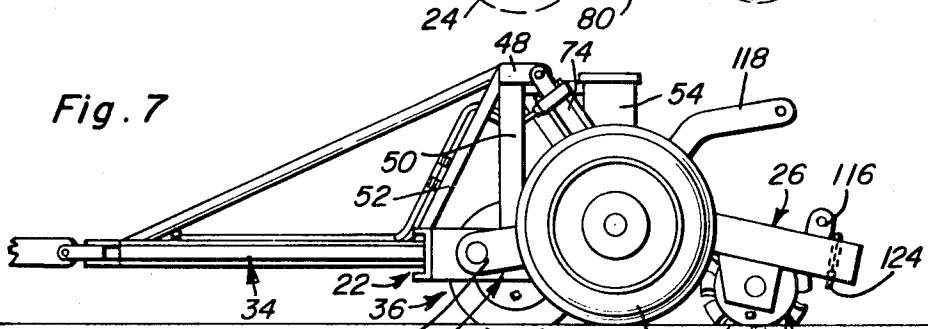

Fig. 8

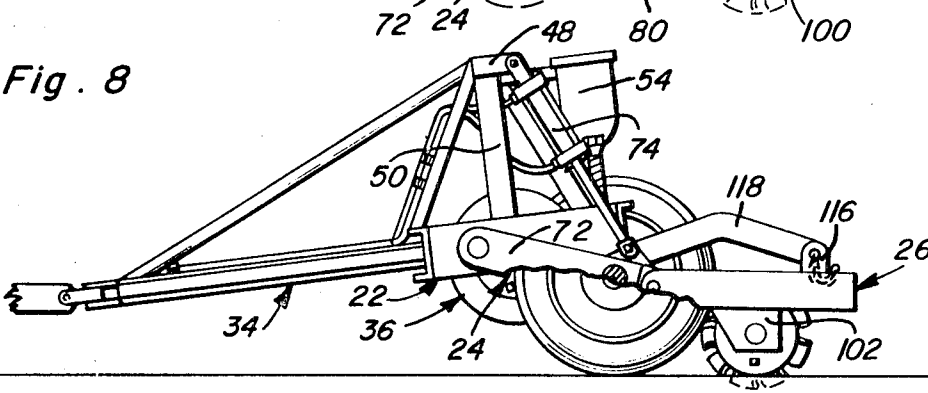
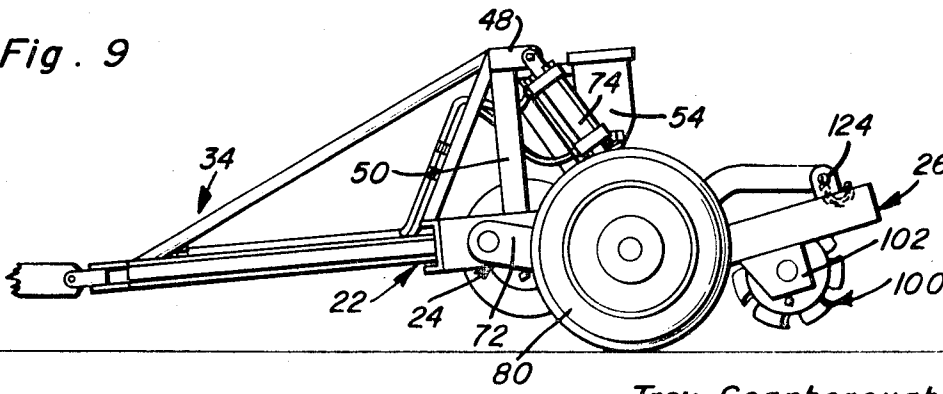

Fig. 9



Troy Scarborough
INVENTOR.

BY *Alfonse A. O'Brien*
and Harvey B. Jacobson
Attorneys

PLANTING MACHINE

The instant invention is generally concerned with field planting, and more particularly relates to a unique planting machine which plows seed-receiving furrows in the ground, deposits seed within the furrows, and subsequently covers the seed.

It is a primary object of the invention to provide a machine which performs the plowing, seeding and covering operations with a single pass of the machine, the individual operating components being power adjusted so as to effectively place the seed at any desired depth, within specific limits.

Another object of the instant invention is to provide a machine wherein the plow roller and the cover roller can be selectively maintained in an elevated position relative to the ground whereby only the ground-engaging traveling wheels support the machine, thereby preparing the machine for highway travel.

Basically, the sought for objects in the instant invention are achieved through the provision of three pivotally interconnected sections including a main plow-supporting section, a ground wheel supporting level control section, and a cover roller supporting trailing section. Power means are engaged between the main frame and the level control frame for varying the angular relation therebetween and hence the degree of support provided by the plow roller and the wheels, the trailing section pivoting in response to an adjustment of the level control frame relative to the main frame so as to maintain a constant engagement of the cover roller with the ground regardless of the particular depth at which the plow roller is forming the seed receiving furrows. Lock means is provided between the level control frame and the trailing frame whereby an interlocking of these frames against pivotal movement relative to each other can be effected, this in turn enabling an elevation of the trailing section and the cover thereon in conjunction with the retention of the plow roller in an elevated position whereby only the traveling wheels are ground engaged. A suitable seedbox is mounted on the main frame and driven from the plow roller itself.

These together with other objects and advantages which will become subsequently apparent reside in the details of construction and operation as more fully hereinafter described and claimed, reference being had to the accompanying drawings forming a part hereof, wherein like numerals refer to like parts throughout, and in which:

FIG. 1 is a top plan view of the planting machine of the instant invention;

FIG. 2 is a front elevational view of the machine;

FIG. 3 is a cross-sectional view of the machine taken substantially on a plane passing along line 3—3 in FIG. 1;

FIGS. 4 and 5 illustrate modified forms of cover rollers;

FIG. 6 is a reduced side elevational view of the machine illustrating the coulters disks engaging the ground at the maximum depth;

FIG. 7 is a view similar to FIG. 6 illustrating the coulters disks at an intermediate depth;

FIG. 8 is a similar view with the level control frame at its maximum pivoted position whereby an engagement of the lock means between the level control frame and the trailing frame can be effected;

FIG. 9 is a similar view illustrating both the main frame and the trailing frame adjusted, relative to the level control frame, so as to raise the plow roller and covering roller for road travel; and

FIG. 10 is a reduced schematic top plan view of the three frames.

Referring now more specifically to the drawings, reference numeral 20 is used to generally designate the planting machine comprising the instant invention. This machine 20 consists basically of a self-supporting unit including three pivotally interconnected frames, a forward main frame 22, a level control frame 24 rearward of the main frame 22, and a trailing frame 26 rearward of the level control frame 24.

The main frame 22 is of a relatively wide rectangular configuration, including forward and rear beams 28 and 30, and opposed side beams 32 rigidly interconnecting the forward and rear beams 28 and 30. A tongue and trailer hitch assembly 34 projects forwardly from the forward beam 28 of the main frame 22 for engagement with an appropriate towing vehicle, such as a conventional tractor, having a hydraulic system provided thereon. An enlarged coulters or plow roller 36 extends transversely across the main frame 22 between the side beam 32, orientated at an angle other than 90° relative to the path of travel of the planting machine 20 so as to enhance the furrow forming action thereof. This coulters roller is formed by the provision of a plurality of coulters disks 38 about an elongated hollow drum 40 which in turn includes end plates 42 from which mounting stub shafts 44 axially project for rotational reception within the opposed side beams 32 whereby a free rolling of the coulters roller 36 will be effected through the engagement of the coulters disks 38 with the ground. The use of a hollow drum 40 as the means for mounting the coulters disks 38 is deemed particularly significant in that ballast, such as water or the like, can be selectively introduced into the interior thereof so as to increase the weight of the coulters roller 36 and increase its ground-penetrating ability. The introduction and removal of the ballast can be effected through a suitable aperture in one of the end walls 42 selectively closed by appropriate plug means 46.

A transversely extending elevated crossbeam 48 extends centrally across the main frame 22 and is supported at the opposed ends thereof by vertical columns 50 secured to and rising from the opposed side beams 32. The crossbeam 48 is also suitably braced by appropriate diagonal bracing beams 52 extending between the columns 50 and the horizontal beams which define the rectangular main frame 22.

An elongated seedbox 54, of conventional construction, is positioned rearward of and parallel to the crossbeam 48, being supported therefrom by suitable rearwardly directed support arms 56. A plurality of seed tubes 58 depend from the seedbox 54 to a point at approximately midheight just forward of the rear main frame beam 30, one seed tube 58 being aligned with each coulters disk 38 for a depositing of the seed within the furrow formed thereby. The operation of the seedbox 54 is to be effected directly from and in response to rotation of the coulters roller 36. As such, a jack shaft 60 is mounted directly below the crossbeam 48, adjacent one end thereof, with the opposite ends of the shaft 60 being rotatably supported within bearings 62, one affixed to the adjacent vertical column 50 and the other affixed to a rigid member 64 affixed to and depending from the crossbeam 48 itself in inwardly spaced relation to the shaft mounting column 50. An endless drive chain 66 extends from and about a first pulley mounted on the adjoining shaft end 44 of the coulters roller 36 and a second pulley keyed to the jack shaft 60 whereby a driving of the jackshaft 60 is effected. This driving of the shaft 60 is in turn translated into a driving of the dispensing apparatus associated with the seedbox 54 by means of a second endless chain 68 engaged about a second pulley on the shaft 60 and an appropriate power-receiving pulley on the seedbox 54. In this manner, as the coulters roller 36 rotates through an engagement with the ground so as to define the seed-receiving furrows, the seedbox 54, or at least the dispensing mechanism therein, is activated so as to discharge the seed through the plurality of seed tubes 58. Once forward movement of the planting machine 20 ceases, a dispensing of the seed also of course ceases. Further, upon a raising of the coulters roller 36 out of operative engagement with the ground, no rolling of the roller 36 will be effected upon a movement of the planting machine 20, and accordingly, there will also be no dispensing of the seed under these circumstances.

The level control frame 24 consists of a transverse crossbeam 70 paralleling the rear beam 30 of the main frame 22 immediately to the rear thereof, and a pair of forwardly extending side beams 72 rigid with the opposed ends of the transverse beam 70 and lying immediately outward of and parallel

to the side beams 32 of the main frame 22. These side beams 72 extend forward along a major portion of the side beams 32 and are pinned at the forward ends thereof to the side beams 32 for a vertical swinging of the level control frame 24 relative to the main frame 22. This actual vertical swinging movement is effected by means of a pair of double-acting hydraulic rams 74, each being pivotally engaged at one end thereof to a rearwardly projecting ear 76 on the crossbeam 48 rigid with the main frame 22, and at the other end thereof to a vertically projecting ear 78 rigidly affixed to the level control frame 24 at the opposed ends of the transverse beam 70. The rams 74 of course are supplied and controlled from the hydraulic system on the towing vehicle through appropriate hydraulic lines 80. With reference to the sequential steps of FIGS. 6, 7 and 8, it will be noted that upon an extension of the hydraulic rams 74, the coultter roller 36, which is rotatably mounted within the main frame 22 between the axis on which the side beams 72 are pivoted to the side beams 32 and the rear beam 30 of the main frame 22, will progressively raise relative to the ground. By the same token, upon a contraction of the same hydraulic rams 74, a progressive lowering of the coultter roller 36 will be effected with the weight of the level control frame 24 being to some extent transferred thereto subsequent to an engagement of the coultter roller 36 with the ground. Incidentally, it will be noted that the pivotal axis of the side beams 72 of the level control frame 24 is also forward of the point at which the columns 50 rise from the main frame 22, the columns 50 being in general alignment with the axis of rotation of the coultter roller 36. Furthermore, as will be readily apparent from the drawings, the two ground-engaging support wheels 80 are mounted on the level control frame 24 at the rearward ends of the two side beams 72 by appropriate stub axles or shafts 82.

Referring now to the trailing frame 26, this frame 26 includes a pair of laterally spaced side beams 84 constituting in effect rearwardly extending pivotally connected continuations of the level control frame side beams 72. The trailing frame side beams 84 are connected to the side beams 72 through a clevis-type forward end 86 on each side beam 84 which receives a rearwardly directed ear 88 rigidly affixed to and extending from the level control frame 24 for the reception of appropriate pivot pin means 90 therethrough, the trailing frame 26 being thereby free to pivotally adjust relative to the level control frame 24. The trailing frame 26 is completed by a removable stabilizer beam 92 extending transversely between the rear ends of the side beams 84, this stabilizer beam 92 including a platelike bracket 94 on each end which is releasably bolted to a similar platelike bracket 96 by appropriate bolt means 98. In this manner, the transverse beam 92 can be easily removed should such be desirable when mounting or replacing the cover roller 100. This cover roller 100, as will be appreciated from the drawings, is rotatably mounted between a pair of depending mounting plates 102 projecting vertically downward from the trailing frame side beams 84. The cover roller 100 itself includes a hollow drumlike body 104 with sealing end walls 106, one of which includes a plug sealed opening 108 through which additional ballast can be introduced and removed. The drum 104 is mounted rotatably on the opposed plates 102, and more particularly on bearing units provided thereon, by means of axially projecting shaft ends 110 whereby the cover roller 100 is free to roll along the ground in conjunction with a forward movement of the planting machine 20.

Various types of earth returning elements can be provided about the central hollow drum 104 of the covering roller 100. For example, the preferred form of roller 100 will incorporate several sets of laterally spaced annularly arranged short angular blades 111 rigidly affixed, as by welding, to the drum 104 and projecting radially outward therefrom. Each of the sets of blades 111 is aligned with a furrow-forming coultter disk 38 so as to close the corresponding furrow subsequent to a deposit of the seed therein. FIG. 4 illustrates another form of covering construction wherein the central drum is surrounded by a series of adjacent angular bars 112 provided annularly about

and directly secured to the drum. FIG. 5 illustrates yet another form of cover roller wherein adjacent rubber earth compacting tires 114 are mounted on the roller drum.

With reference to FIG. 9, it will be noted that the trailing frame 26 with the covering roller 100 thereon is to be fixed in an upwardly pivoted position for road travel. In order to effect this, the trailing frame 26, and more particularly the side beams 84 thereon, are provided with a pair of rigid upstanding ears 116. Likewise, the level control frame 24 is provided with a pair of upwardly and rearwardly arching rigid arms 118, the ears 116 and arms 118 being provided with pin-receiving apertures 120 and 122 therein which align with each other upon an upward pivoting of the trailing frame 26 relative to the level control frame 24 for the reception of a chain mounted pin 124 therethrough whereby a positive locking of the trailing frame 26 to the level control frame 24 is effected.

In operation, the planting machine 20 is engaged to the hitch of a towing vehicle and the orientation of the frames adjusted, through the hydraulic rams 74, to accommodate the particular soil being worked. For example, FIG. 6 illustrates the rams 74 fully retracted, this in turn pivoting the forward main frame 22 to its lowermost position whereby a maximum weight is introduced in the coultter or plow roller 36. FIG. 7 illustrates the machine in a position with the rams 74 slightly extended, thereby swinging the main frame 22, and hence the coultter roller 36, slightly upward between the tractor hitch and the level control frame 26 which is in turn ground supported through the ground-engaging wheels or tires 80. FIG. 8 illustrates the fully extended position of the power rams 74 wherein the main frame, supported at the extreme forward end of the tongue structure 34 on the tractor hitch, is swung upwardly, pivoting about the engagement between the tongue unit and tractor hitch, so as to substantially elevate the plow roller 36. In this position, the lock arms 118 are aligned with the lock ears 116 on the trailing frame 26 for the reception of the lock pins 124 therethrough. The final step in converting the machine 24 for road travel is a retraction of the hydraulic rams 74 a sufficient distance so as to elevate the cover roller 100 above the ground without reengaging the coultter roller 36. This result is achieved in that the contraction of the rams 74 results in a downward swinging of the main frame and a corresponding upward swinging of the level control frame, both frames moving to a generally horizontal position with the upward swinging of the main frame in turn resulting in an upward swinging of the trailing frame locked thereto. The planting machine or seeder 20 is thus oriented for road travel on the two wheels 80. This particular sequence of operational steps will be reversed when it becomes desired to again position the machine 20 in inoperative condition with the specific operational orientation of the main frame relative to the level control frame being determined by the condition of the soil encountered. As previously indicated, additional weight can be added to both rollers through the introduction of ballast inferiorly therein.

From the foregoing it will be appreciated that a unique planting machine has been defined, this machine incorporating furrow-forming means, material-dispensing means for a deposit of the material, normally seed, within the formed furrows, and furrow-covering means for closing the furrows subsequent to the deposit of the material therein. All of this is accomplished with a single pass of the machine with the machine itself being hydraulically adjusted, even during operation, so as to vary the depth of furrow formed and likewise accommodate itself to varying soil conditions. By the same token, the machine is easily adjusted so as to elevate the ground working rollers and lock such in elevated positions so as to enable highway travel on a pair of traveling wheels or tires.

The foregoing is considered as illustrative only of the principles of the invention. Further, since numerous modifications and changes will readily occur to those skilled in the art, it is not desired to limit the invention to the exact construction and operation shown and described, and accordingly all suitable modifications and equivalents may be resorted to, falling within the scope of the invention.

What is claimed as new is as follows:

1. A soil-working machine comprising a substantially horizontal main frame, said frame including forward, rear and opposed side portions, ground engageable plow means mounted on said main frame and extending transversely thereacross between the opposed side portions thereof, a level control frame generally paralleling said main frame toward the rear thereof, means pivotally engaging said level control frame with scope main frame for vertical pivoting of the level control frame relative to said main frame, ground support wheels mounted on said level control frame for pivotal movement therewith, a trailing frame generally paralleling said level control frame toward the rear thereof, means pivotally engaging said trailing frame with said level control frame for free vertical pivoting of the trailing frame relative to said level control frame, ground engageable cover means mounted on said trailing frame for pivotal movement therewith, power means engaged between said main frame and said level control frame for effecting a pivotal variation therebetween, the pivotal angle of the trailing frame relative to the level control frame freely and automatically varying in response to vertical movements of the level control frame because of ground surface variations whereby a generally constant orientation of the cover means relative to the ground is maintained, material-dispensing means mounted on said machine and selectively discharging between the plow means and the cover means, lock means for selectively locking said trailing frame to said level control frame whereby free pivotal movement therebetween is precluded and an elevation of the cover means above the ground can be effected through a pivotal adjustment of the level control frame by said power means, said lock means comprising at least one rigid upwardly projecting ear on said trailing frame, and a corresponding rearwardly directed lock arm on said level control frame, said lock arm and said ear being alignable upon a pivotal adjustment of said level control frame to a predetermined point, and lock pin means engageable between said lock arm and said ear for a locking of said ear, and hence the trailing frame, to said arm.

2. The machine of claim 1 wherein said material-dispensing means is mounted on said main frame in vertically spaced relation above said plow means, and drive means engaged between said plow means and said dispensing means for an activation of said dispensing means in response to a movement of said plow means induced by an engagement of the plow means with the ground during the travel of the machine.

3. The machine of claim 2 wherein said main frame includes a pair of laterally spaced side beams defining said side portions, and means rigidly interconnecting said side beams, said level control frame including a pair of laterally spaced parallel side beams, each of said level control frame side beams overlying and having the forward end portions thereof pivoted to the main frame side beams toward the forward end portions of the main frame side beams, said level control frame side beams projecting rearwardly of the main frame and each mounting a ground support wheel approximately at the rear of the main frame, said trailing frame including a pair of laterally spaced parallel side beams extending generally longitudinally rearward of the level control frame side beams, said means pivotally engaging said trailing frame with said level control frame constituting a pivotal connection between the forward end of each trailing frame beam and the rear end of the corresponding level control frame side beam, said ground engageable cover means extending between and being mounted on said trailing frame side beams.

4. The machine of claim 3 including a rigid forwardly projecting tractor engageable tongue unit rigidly secured to the forward portion of said main frame.

5. The machine of claim 4 including an elongated transversely extending crossbeam spanning said main frame in spaced relation over said main frame, column means extending between the main frame side beams and said transversely extending beam, said power means being pivotally engaged with said transversely extending beam and extending rearwardly and downwardly therefrom for pivotal engagement with said

level control frame whereby an extension of said power means will effect a corresponding raising of the rear portion of the main frame and forward portion of the level control frame, the rear portion of the level control frame lowering and causing a corresponding upward pivoting of the trailing frame.

6. The machine of claim 5 wherein said plow means comprises an elongated hollow cylindrical ballast-receiving drum having a plurality of coulter disks affixed thereto in laterally spaced relation to each other along the length of said drum.

7. The machine of claim 6 wherein said cover means comprises an elongated hollow ballast-receiving drum and earth moving means provided thereabout along the length thereof and in general alignment with the coulter disks on said plow means.

8. A soil-working machine comprising a substantially horizontal main frame, said frame including forward, rear and opposed side portions, ground engageable plow means mounted on said main frame and extending transversely thereacross between the opposed side portions thereof, a level control frame generally paralleling said main frame toward the rear thereof, means pivotally engaging said level control frame with said main frame for vertical pivoting of the level control frame relative to said main frame, ground support wheels mounted on said level control frame for pivotal movement therewith, a trailing frame generally paralleling said level control frame toward the rear thereof, means pivotally engaging said trailing frame with said level control frame for free vertical pivoting of the trailing frame relative to said level control frame, ground engageable cover means mounted on said trailing frame for pivotal movement therewith, power means engaged between said main frame and said level control frame for effecting a pivotal variation therebetween, the pivotal angle of the trailing frame relative to the level control frame freely and automatically varying in response to vertical movements of the level control frame because of ground surface variations whereby a generally constant orientation of the cover means relative to the ground is maintained, material-dispensing means mounted on said machine and selectively discharging between the plow means and the cover means, said main frame including a pair of laterally spaced side beams defining said side portions, and means rigidly interconnecting said side beams, said level control frame including a pair of laterally spaced parallel side beams, each of said level control frame side beams overlying and having the forward end portions thereof pivoted to the main frame side beams toward the forward end portions of the main frame side beams, said level control frame side beams projecting rearwardly of the main frame and each mounting a ground support wheel approximately at the rear of the main frame, said trailing frame including a pair of laterally spaced parallel side beams extending generally longitudinally rearward of the level control frame side beams, said means pivotally engaging said trailing frame with said level control frame constituting a pivotal connection between the forward end of each trailing frame beam and the rear end of the corresponding level control frame side beam, said ground engageable cover means extending between and being mounted on said trailing frame side beams.

9. The machine of claim 8 including a rigid forwardly projecting tractor engageable tongue unit rigidly secured to the forward portion of said main frame.

10. The machine of claim 9 including an elongated transversely extending crossbeam spanning said main frame in spaced relation over said main frame, column means extending between the main frame side beams and said transversely extending beam, said power means being pivotally engaged with said transversely extending beam and extending rearwardly and downwardly therefrom for pivotal engagement with said level control frame whereby an extension of said power means will effect a corresponding raising of the rear portion of the main frame and forward portion of the level control frame, the rear portion of the level control frame lowering and causing a corresponding upward pivoting of the trailing frame.

7

8

11. The machine of claim 10 wherein said material-dispensing means is mounted on said transversely extending beam rearwardly thereof, and drive means engaged between said plow means and said dispensing means for a selective activation of said dispensing means in response to a ground-motivated movement of said plow means.

12. An articulated framework for a planting machine or the like comprising a main frame including laterally spaced parallel side beams and at least one transversely extending beam rigidly interconnecting said side beams, a forwardly projecting tractor engageable tongue unit rigidly engaged with said main frame and projecting forward therefrom, a level control frame projecting generally rearward of the main frame, said level control frame including a pair of laterally spaced parallel side beams paralleling the main frame side beams and overlapping these beams, pivot means engaging the forward ends of the level control frame beams with said main frame side beams, power means engaged between said main frame and said level control frame for effecting a pivotal adjustment therebetween and a corresponding raising and lowering thereof, a trailing

5 frame, said trailing frame including a pair of laterally spaced parallel side beams, means pivotally connecting the forward end of each trailing frame side beam with the rear end portion of the adjacent level control frame side beams for a free pivotal movement of the trailing frame relative to the level control frame, and means selectively engageable between the trailing frame and level control frame for locking the trailing frame to the level control frame whereby the free pivotal movement therebetween can be selectively precluded and an adjustment of the trailing frame with the level control frame can be effected to elevate the trailing frame away from the ground.

13. The framework of claim 12 including plow means mounted on and depending from said main frame, a cover roller mounted on and depending from said trailing frame and seed-dispensing means mounted rearward of said plow means and operative in response to ground induced movement of said plow means, said level control frame incorporating ground-engaging traveling wheels.

25

30

35

40

45

50

55

60

65

70

75