

(19) World Intellectual Property Organization
International Bureau



(43) International Publication Date
7 October 2010 (07.10.2010)

(10) International Publication Number
WO 2010/112603 A1

- (51) **International Patent Classification:**
B63B 21/50 (2006.01) *B63B 22/04* (2006.01)
- (21) **International Application Number:**
PCT/EP2010/054461
- (22) **International Filing Date:**
2 April 2010 (02.04.2010)
- (25) **Filing Language:** English
- (26) **Publication Language:** English
- (30) **Priority Data:**
09157218.0 2 April 2009 (02.04.2009) EP
- (71) **Applicant (for all designated States except US):** **SINGLE BUOY MOORINGS INC.** [CH/CH]; Route de Fri-
bourg 5, CH-1723 Marly (CH).
- (72) **Inventors; and**
- (75) **Inventors/Applicants (for US only):** **BAUDIN, Chris-
tian** [FR/FR]; Villa Miradou 2, escalier du Chateau d'eau,
FR-06360 Eze (FR). **BRAUD, Jean** [FR/FR]; 3 Chemin
des Oliviers, FR-06320 La Turbie (FR).
- (74) **Agent:** **KETELAARS, Maarten;** J.W. Frisolaan 13,
NL-2517 JS The Hague (NL).
- (81) **Designated States (unless otherwise indicated, for every
kind of national protection available):** AE, AG, AL, AM,

AO, AT, AU, AZ, BA, BB, BG, BH, BR, BW, BY, BZ, CA, CH, CL, CN, CO, CR, CU, CZ, DE, DK, DM, DO, DZ, EC, EE, EG, ES, FI, GB, GD, GE, GH, GM, GT, HN, HR, HU, ID, IL, IN, IS, JP, KE, KG, KM, KN, KP, KR, KZ, LA, LC, LK, LR, LS, LT, LU, LY, MA, MD, ME, MG, MK, MN, MW, MX, MY, MZ, NA, NG, NI, NO, NZ, OM, PE, PG, PH, PL, PT, RO, RS, RU, SC, SD, SE, SG, SK, SL, SM, ST, SV, SY, TH, TJ, TM, TN, TR, TT, TZ, UA, UG, US, UZ, VC, VN, ZA, ZM, ZW.

(84) **Designated States (unless otherwise indicated, for every kind of regional protection available):** ARIPO (BW, GH, GM, KE, LR, LS, MW, MZ, NA, SD, SL, SZ, TZ, UG, ZM, ZW), Eurasian (AM, AZ, BY, KG, KZ, MD, RU, TJ, TM), European (AT, BE, BG, CH, CY, CZ, DE, DK, EE, ES, FI, FR, GB, GR, HR, HU, IE, IS, IT, LT, LU, LV, MC, MK, MT, NL, NO, PL, PT, RO, SE, SI, SK, SM, TR), OAPI (BF, BJ, CF, CG, CI, CM, GA, GN, GQ, GW, ML, MR, NE, SN, TD, TG).

Published:

- with international search report (Art. 21(3))
- before the expiration of the time limit for amending the claims and to be republished in the event of receipt of amendments (Rule 48.2(h))

(54) **Title:** DISCONNECTABLE CHAIN CONNECTOR

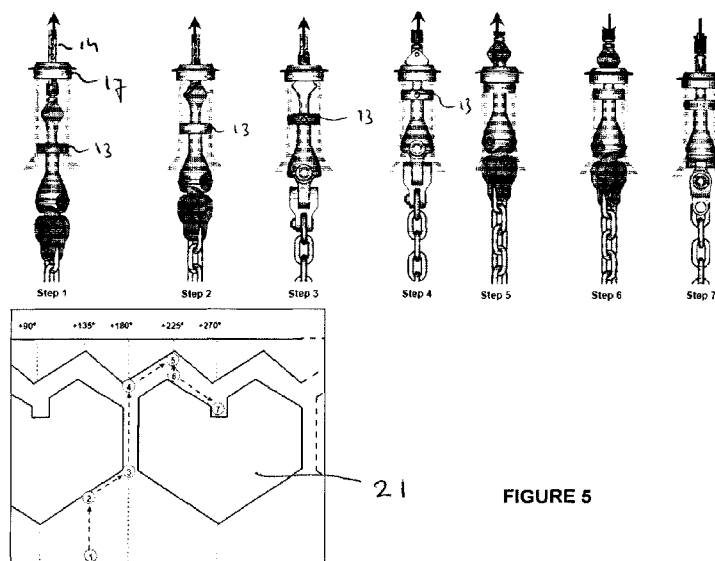

FIGURE 5

(57) **Abstract:** This invention relates to a mooring leg connector for use with a mooring leg extending up from the sea floor to connect a floating structure to be moored to the seabed wherein disconnection and connection of the mooring leg is done by pulling in and out a connector elongated body extending in the mooring leg direction, said connector having a latch mechanism for fixation of the mooring leg to the floating structure to be moored and preventing movement in the direction of the seabed, and a flexible part with a double articulation axis located at the bottom of the connector body above the attachment member, the connector body being received in a housing which is fixed to a part of the structure to be moored, wherein the latch mechanism comprises guiding means and followers or orientation pins between the body of the connector and the housing.

WO 2010/112603 A1

DISCONNECTABLE CHAIN CONNECTOR

FIELD OF THE INVENTION

5 The present invention relates to a mooring leg connector for use with a mooring leg extending up from the sea floor to connect a floating structure to be moored to the seabed wherein disconnection and connection of the mooring leg is done by pulling in and out the connector elongated body extending in the mooring leg direction, the connector having a latch mechanism for fixation of the mooring leg to the floating structure to be
10 moored and preventing movement in the direction of the seabed, and a flexible part with a double articulation axis located at the bottom of the connector body above the attachment member, the connector being received in a housing which is fixed to a part of the structure to be moored.

The present invention also relates to methods for locking and unlocking a mooring leg
15 connector to a floating structure to be moored to the seabed, said connector having an elongated body extending in the mooring leg direction and a latch mechanism for fixation of the mooring leg to the floating structure to be moored and preventing movement in the direction of the seabed.

20

BACKGROUND OF THE INVENTION

In US patent US6663320 (filed by the applicant), there is disclosed a anchor line connector to connect an anchor line to a floating body, the connector comprising a housing having two mutually perpendicular pivot axis , a flexible top part and a latch
25 mechanism for allowing movement of the anchor line towards the floating body.

The solution described in this patent concerns a pivoting connector that can pivot around an axis such that the mooring lines can move in radial plane but that can also pivot around another axis perpendicular to the first one. Hence the bending fatigue in the chain part is limited and fatigue failure in transversely oriented links is prevented.

30 However the fatigue failure and wear can further be optimized by having the tubular member fixed and the connection means decoupled from the pivoting means.

US4943188 discloses a tether connector that includes a first member secured to the sea floor and a second member secured to the lower end of the tether. A ring having a central vertical axis and with horizontal lugs is provided. A cylindrical receptacle also having a central vertical axis and including a primary guide, a vertical slot, a secondary guide and a notch is provided. The ring and receptacle are mounted on the members to permit relative rotation between the ring and receptacle about the central axis of the tendon. The solution proposed aims at securing tethers to a sea floor receptacle mechanism, these solutions are not ideal as inspection of the articulation in dry environment are not possible without disconnecting, further maintenance operation are not eased.

The present invention proposes a solution which would enable to have a chain connector that can accommodate any type of mooring leg. The main advantages of the system according to the present invention are the ability to be operated without the need for divers, both during connection and disconnection. This chain connector can be easily disconnected with a simple pulling operation, and can be brought on the deck of a supply vessel. This feature allows an easy inspection of the articulation in dry condition without the need to disconnect. The chain can be retensioned, by cutting off excess chain links. Furthermore, on the supply vessel deck the parts that may have been affected by wear can be eventually replaced. The overall size and weight are reduced with respect to standard connectors allowing therefore reduction of the buoyancy requirements of the moored floating structure

SUMMARY OF THE INVENTION

The invention provides a mooring leg connector for use with a mooring leg extending up from the sea floor to connect a floating structure to be moored to the seabed wherein disconnection and connection of the mooring leg is done by pulling in and out the connector elongated body extending in the mooring leg direction, the connector having a latch mechanism for fixation of the mooring leg to the floating structure to be moored and preventing movement in the direction of the seabed, and a flexible part with a double

articulation axis located at the bottom of the connector body above the attachment member, the connector being received in a housing which is fixed to a part of the structure to be moored, the latch mechanism comprising a system of cam or guiding means and followers or orientation pins between the rod of the connector and the housing. Another object of the invention is to provide a mooring leg connector for use with a mooring leg that has an upper portion with an axis, where the chain extends up from the sea floor, to connect the bottom of a turret integrated into or attached to the hull of a floating structure to be moored to the seabed, said connector having an elongated body extending in the mooring leg direction and a latch mechanism for fixation of the mooring leg to the floating structure to be moored and preventing movement in the direction of the seabed, the connector being received in a housing which is integral (or at least rigidly connected) to a part of the structure to be moored, wherein the connector comprises a flexible part with a double articulation axis located at the bottom of the connector body above the attachment member and wherein the latch mechanism is a system made by cam (or guiding member) and followers (or orientation pins) between the rod of the connector and the housing.

According to the present invention the connector comprises a rod provided with at least one pin that will enter a guiding member integrated inside the housing to rotate the rod inside the housing into a proper alignment and lock the connector.

The present invention also provides a method for locking a mooring leg connector to a floating structure to be moored to the seabed, said connector having an elongated body extending in the mooring leg direction and a latch mechanism for fixation of the mooring leg to the floating structure to be moored and preventing movement in the direction of the seabed, the method comprising the following steps:

- Bring the floating structure to be moored at the right location
- Collect the pull-in chain attached at the upper part of the elongated body of the connector
- Pull on the pull-in chain passing through the housing which is rigidly fixed to a part of the floating structure to be moored so that

- the elongated body of the connector is also pulled through the housing

- the rod of the connector body is pulled through the housing, the orientation pins provided on the rod automatically enters the guiding means integrated inside the housing

- the rod translates and rotates following the guiding means

- the orientation pins enter a non return location within the guiding means

- Once the pins are blocked in the guiding means, the connector body is locked and the pulling is stopped.

An embodiment of the present invention provides a method for disconnecting a mooring leg connector of a structure moored to the seabed, said connector having an elongated body extending in the mooring leg direction and a latch mechanism for fixation of the mooring leg to the structure moored and preventing movement in the direction of the seabed, the method comprising the following steps:

- Pull on the pull-in chain attached at the upper part of the elongated body up so that the orientation pins can enter the guiding means via a determined slot that will force the rod of the connector body to rotate

- By rotating and translating the rod, the orientation pins are following the cam system of the housing, until it exits the housing

- Lowering the pull-in chain to complete the disconnection and the pulling is stopped.

BRIEF DESCRIPTION OF THE DRAWINGS

The invention will be further described below in connection with exemplary embodiments with reference to the accompanying drawings, wherein:

FIG.1 shows a perspective view of the chain connector according to the present invention,

FIG.2 shows a cross-sectional view of the connector according to the present invention,

FIG.3 shows the load cells located in the chain connector body interface,
FIG.4 shows the positions of the chain connector according to the present invention before and after connection and the development of the chain connector housing,
FIG.5 shows the different steps of the connection of the chain connector by means of a system of cam and cam followers according to the present invention and the positions of the chain connector (orientation pins) with regards to the development of the receptacle (cam) during these different steps, and
FIG.6 shows the different steps of the disconnection of the chain connector by means of a system of cam and cam followers according to the present invention and the positions of the chain connector (orientation pins) with regards to the development of the receptacle (cam) during these different steps.

DESCRIPTION OF THE PREFERRED EMBODIMENTS

FIG.1 shows a perspective view of the chain connector according to the present invention and FIG.2 shows cross-sectional view of the chain connector according to the present invention. In these figures, it appears clearly that the connector has an elongated body 1, received in a housing 9, with a broad head part 3 for attaching the pull-in chain 14, a tubular shaped middle part or rod 2 getting larger towards the bottom part 4, said bottom part comprising an enlargement 5 for engaging the flexible lower part 6 with a double articulation. The double articulation allows pivoting of the upper link of the mooring leg as would a unijoint. According to the present invention, the articulated part is located at the bottom of the connector body above the attachment member 7, where the mooring leg 8 is attached. The part 15 (or roll body) of the flexible lower part 6 'rolls' with regard to part 16 (or pitch body) which 'pitches' with respect to the rod 2; the latter is supported by the retaining ring 17 on the top of the housing 9 which is integrated into the chaintable of the structure to be moored.

The pitch articulation is mounted on the dedicated skirt support structure and the roll articulation is integrated in the pitch body 16 which makes the system compact. The role of the pitch body 16 is to permit the chain 8 to align with the tension in the pitch direction

and then to prevent fatigue in chain. The pitch body 16 is therefore rotating relatively to the pitch axis of the chain connector.

Shafts are linked to the pitch and roll articulation (roll for lower shaft, pitch for upper shaft) through locking pins (not shown) that are at the interface between articulations and
5 low friction items.

The rod 2 allows to get the required lever arm and to fix the upper chain segment 8 to the connector. The rod 2 is the center piece of the chain connector. Its role is to transfer the mooring load and to provide a system for the connection / disconnection of the chain connector. It is locked to the chain table by the retaining ring 17. As clearly shown in
10 FIG.1, the rod 2 is provided with a guiding ring 18. The guiding ring 18 ensures the centering of the rod 2 in the structure housing 9 during installation (through its diameter and its shape). The guiding ring is provided with orientation pins 13 that have the role of cam followers during the connection and the disconnection of the chain connector. They drive the rod in rotation during the connection and disconnection phases. In addition, the
15 rod 2 is maintained in the chain guide with a tight fit at the bottom as clearly shown in FIG.2.

The connector elongated body 1 is received in the through bone 20 of the housing 9. In a preferred embodiment, the housing 9 is integral or at least rigidly linked to a part of the structure to be moored. By having the housing 9 rigidly linked to the structure, as well as
20 the pivoting axis at the bottom of the connector body 1, the fatigue failure and wear are very limited. In fact, the housing limits the movements of the rod 2 in the tangential direction and transfers the axial tension (coming from the retaining ring 17). It provides also the cam 21 to drive in rotation the rod 2 during connection and disconnection of the chain connector and the conical shape eases the entry of the rod 2 during installation.

25 The retaining ring 17 is an annular piece which locks the rod 2 in the vertical direction and transfers the load to load cells for monitoring the anchor line tension.

The structure to be moored, according to one embodiment of the present invention, can comprise a floating platform unit provided with a mooring buoy and a mooring system
30 having in total four bundles of five mooring lines 8 per bundle, which means that twenty chain connectors are mounted in the chain table at the bottom of the mooring buoy (i.e. in

a permanently submerged position). Each of these chain connectors will be equipped with load cells as shown in FIG. 3. The anchor line tension for each of the twenty lines is monitored by incorporating four redundant load cells located in the chain connector body interface, so eighty load cells in total. Each load cell has an internal redundancy and is equipped with two connectors. The system is fully redundant meaning that the loss of one sensor does not impair the line tension measurement accuracy. The eighty load cells are connected to the floating platform unit through four stab plates (not shown). Each load cell is connected by two individual cables, routed through a pipe into the mooring buoy to the lower stab plate half. The cables are connected to the stab plate buoy side by mean of connectors. Each stab plate is equipped with ten connectors suitable for twenty wires each. Two connectors are dedicated by chain tension measurement; one connector for the four duty load cells and one connector for the four internal redundancies. The load values are transmitted as digital signals. These signals are wired to the anchor leg load monitoring system.

All cabling must have an outer sheath highly resistant to mechanical damage, and be suitable for use in hazardous areas. The length of the cable shall permit the connection between the load cell in the chain connector and the lower stab plate on the buoy.

FIG.4 shows the positions of the chain connector according to the present invention before and after connection and the development of the chain connector housing 9. It shows clearly the cam 21 integrated in the inside of the housing 9. The cam is driving the orientation pins 13 (or followers) provided on the guiding ring 18 of the rod 2. By pulling on the rod 2 (via pulling on the pull-in chain with a winch installed on the structure to be moored), the cam 21 causes the rod 2 rotate until the pins 13 go in position. There the pulling force is released and the mooring leg 8 is connected, the broad head part 3 resting on the retaining ring 17.

For disconnection, the connector's rod 2 is pulled again, and after another rotation of the rod 2, forced by the cam 21, the elongated body 1 of the connector is released.

The cam or guiding means 21, representing a helicoidal ramp inside the housing 9, has a shape designed to guide the pins 13 of the rod 2 and hence rotate the rod 2 so as to be properly aligned.

5 FIG.5 shows the different steps of the connection of the chain connector by means of a system of cam 21 and cam followers 13 according to the present invention and the positions of the chain connector (orientation pins) with regards to the development of the receptacle (cam) during these different steps. The chain connector is connected only by pulling in (from step 1 to 5) and pulling out (in step 6 and 7) the pull-in chain 14.

10 In position 1, the chain 14 pulls the connector which is disconnected. In position 2 the orientation pins (followers) 13 come in contact with the housing 9 and the system of the cams 21 integrated on the inside of the housing 9. The orientation pins 13 follow the cam and the system (chain connector and mooring chain 8) translates upwards and rotates until the position 3. Between the positions 3 and 4, the system translates upwards without rotation, passing through the opening of the retaining ring 17. From the position 4 to the
15 position 5 the system translates and rotates by 45°. In position 5 the pull-in chain 14 pull-out starts and the system translates downwards without rotation until the position 6. Between the position 6 and the last position 7 the system translates downwards and rotates by 45°. In the position 7 the connector is connected. During connection, the
20 maximum rotation is equal to 180°.

FIG.6 shows the different steps of the diverless disconnection of the chain connector by means of a system of cam and followers according to the present invention and the positions of the chain connector (orientation pins) with regards to the development of the
25 receptacle (cam) during these different steps. The chain connector is disconnected only by pulling in (from step 1 to 3) and paying out (from step 4 to step 6) the pull-in chain 14. In position 1 the pull-in chain 14 pulls the chain connector which is connected. In position 2 the orientation pins 13 come in contact with the housing 9 and the system of cam 21 integrated on the inside of the housing 9. The system (chain connector and
30 mooring chain 8) translates upwards and rotates by 45° until the position 3. In position 3, the pull-in chain 14 pull-out starts and the system translates downwards without rotation

until the position 6. Between the positions 3 and 4, the system translates downwards without rotation. From position 4 to position 5, the system translates downwards and rotates by 45°. In position 5, the chain connector is orientated and can pass through the opening of the retaining ring 17. From position 5 to position 6 the system translates downwards without rotation and the mooring chain connector is disconnected. During disconnection, the maximum rotation is equal to 90°.

As will be apparent to those skilled in the art in the light of the foregoing disclosure, many alterations and modifications are possible in the practice of this invention without departing from the spirit or scope thereof. Accordingly, the scope of the invention is to be construed in accordance with the substance defined by the following claims.

CLAIMS

1. A mooring leg connector for use with a mooring leg (8) extending up from the sea floor to connect a floating structure to be moored to the seabed wherein disconnection and connection of the mooring leg (8) is done by pulling in and out
5 a connector elongated body (1) extending in the mooring leg direction, said connector having a latch mechanism for fixation of the mooring leg (8) to the floating structure to be moored and preventing movement in the direction of the seabed, and a flexible part with a double articulation axis located at the bottom of
10 the connector body (1) above the attachment member (7), the connector body (1) being received in a housing (9) which is fixed to a part of the structure to be moored, wherein the latch mechanism comprises guiding means (21) and followers or orientation pins (13) between the body (1) of the connector and the housing (9).
- 15
2. A mooring leg connector as claimed in claim 1, wherein the connector comprises a rod (2) provided with orientation pins (13) that will engage with a guiding member (21), integrated inside the housing (9), forcing the rod (2) to rotate inside the housing (9) into a proper alignment and lock the connector body (1).
- 20
3. A mooring leg connector according to any preceding claims wherein the elongated body (1) is fixed relative to the moored structure.
4. A mooring leg connector according to any preceding claims wherein the housing
25 (9) has a through bone (20) through which the elongated body (1) can extend, the elongated body (1) having an upper part (3) that extends upward beyond said housing (9).
5. A mooring leg connector according to any preceding claims wherein a pull-in line
30 (14) is provided at the upper part (3) of the elongated body (1) to position the body (1) in the housing (9) and act on the body (1) for locking and unlocking.

6. A mooring leg connector according to any preceding claims wherein the locking and unlocking of the connector is achieved by pulling in and out the pull-in line (14) attached to the top part (3) of the rod (2).
- 5
7. A mooring leg connector according to any of the preceding claims wherein the connector is adapted for the retensioning of the mooring leg (8).
8. A mooring leg connector according to any of the preceding claims wherein the connector is provided with a load monitoring device.
- 10
9. A mooring leg connector according to claim 8 wherein the connector is equipped with at least one load cell.
- 15
10. A mooring leg connector according to any preceding claims wherein the elongated body (1) of the connector has a broad head part (3) for attaching the pull-in line (14), a cylindrically shaped middle part (2) with a broodend bottom part (4), said bottom part (4) comprising an enlargement (5) for engaging a flexible lower part (6) provided with a double articulation.
- 20
11. Floating platform unit provided with a mooring buoy and a mooring system comprising at least one bundle of mooring lines (8) wherein for each mooring line (8) there is mounted in the chain table at the bottom of the mooring buoy, a mooring leg connector according to any of the preceding claims.
- 25
12. A method for locking a mooring leg connector to a floating structure to be moored to the seabed, said connector having an elongated body (1) extending in the mooring leg direction and a latch mechanism for fixation of the mooring leg (8) to the structure to be moored and preventing movement in the direction of the seabed, the method comprising the steps of:
- 30
- Bringing the floating structure to be moored at the right location

- Collecting the pull-in line (14) attached at an upper part (3) of the elongated body (1) of the connector
- Pulling the pull-in line (14) passing through the housing (9) which is fixed to a part of the floating structure to be moored so that
 - 5 - the elongated body (1) of the connector is pulled into the housing (9)
 - the rod (2) of the connector body (1) is pulled into the housing (9), orientation pins (13) provided on the rod (2) engaging with the guiding means (11) integrated inside the housing (9)
 - 10 - the rod (2) translating and rotates following the guiding means (21)
 - the orientation pins (13) entering a non-return location within the guiding means (21), and
 - 15 - Blocking the orientation pins (13) in the guiding means (21), and locking of the connector body (1) followed by stopping of pulling on the pull-in line (14).

13. Method according to claim 12 wherein the pull-in line (14) is pulled via a winch installed on the structure to be moored.

20

14. A method for disconnecting a mooring leg connector of a structure moored to the seabed, said connector having an elongated body (1) extending in the mooring leg direction and a latch mechanism for fixation of the mooring leg (8) to the structure and preventing movement in the direction of the seabed, the method comprising the following steps:

25

- Pulling on the pull-in line (14) attached at the upper part (3) of the elongated body (1), so that orientation pins (13) can engage with the guiding means (21) via a determined slot that forces a rod (2) of the connector body (1) to rotate,

- Rotating and translating the rod (2), wherein the orientation pins (13) are following the cam system (21) of the housing (9), until the rod (2) exits the housing (9), and
- Lowering the pull-in line (14) to complete the disconnection and the pulling is stopped.

5

15. Method according to claim 14 wherein the pull-in line (14) is lowered via a winch installed on the moored structure.

10 16. A cam follower system for actuating the connection and/or disconnection of a mooring leg connector, comprising:
a cam or guiding means (21) integrated on the inside of a housing (9),
followers or orientation pins (13) provided on a guiding ring (18) of the connector elongated body (1) which is received in the housing (9).

15

17. A cam follower system as claimed in claim 16 wherein the cam system is fixed and the follower is forced to move in a particular way by following the profile of the cam only by pulling in or paying out the pull-in line (14) attached to the top part (3) of the rod (2) of the connector body (1).

20

25

30



FIGURE 1

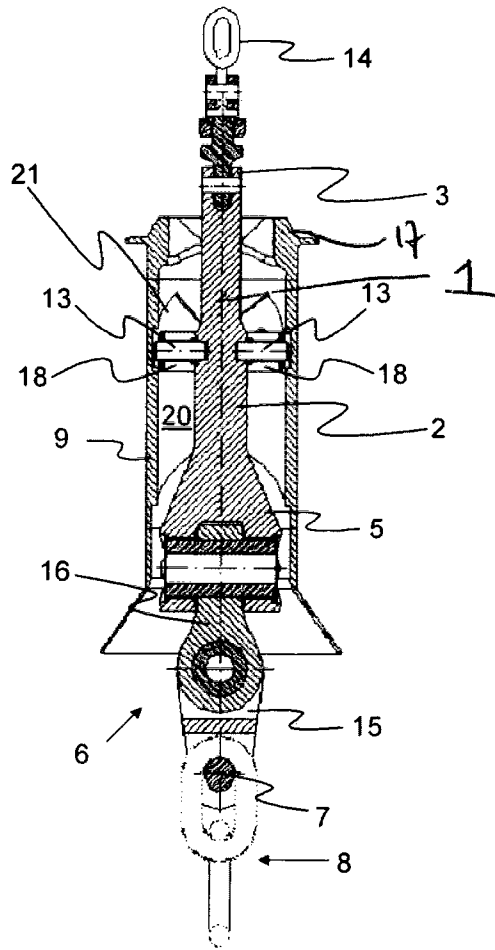

FIGURE 2

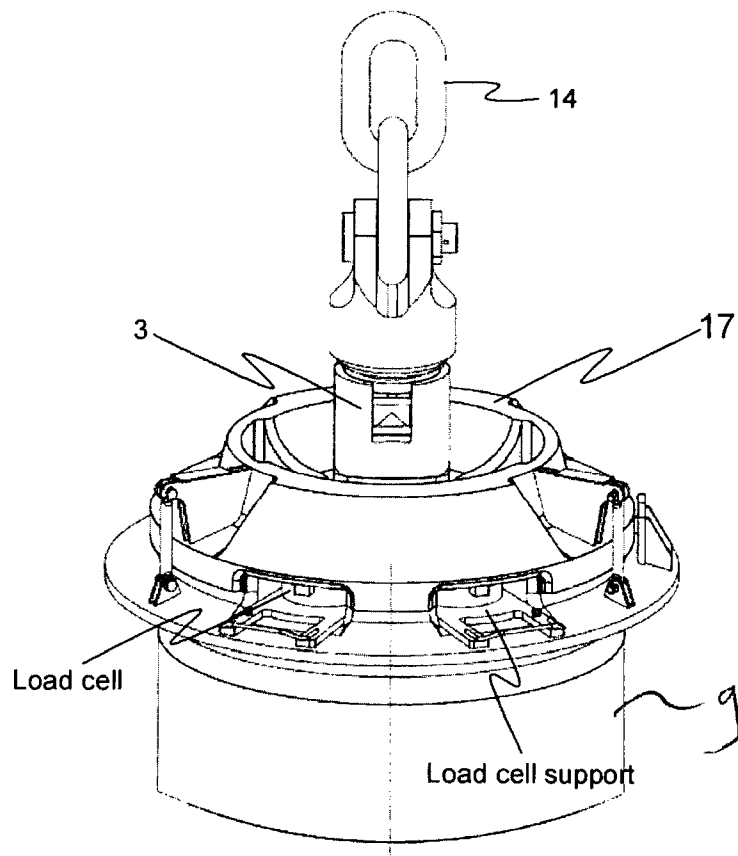

FIGURE 3

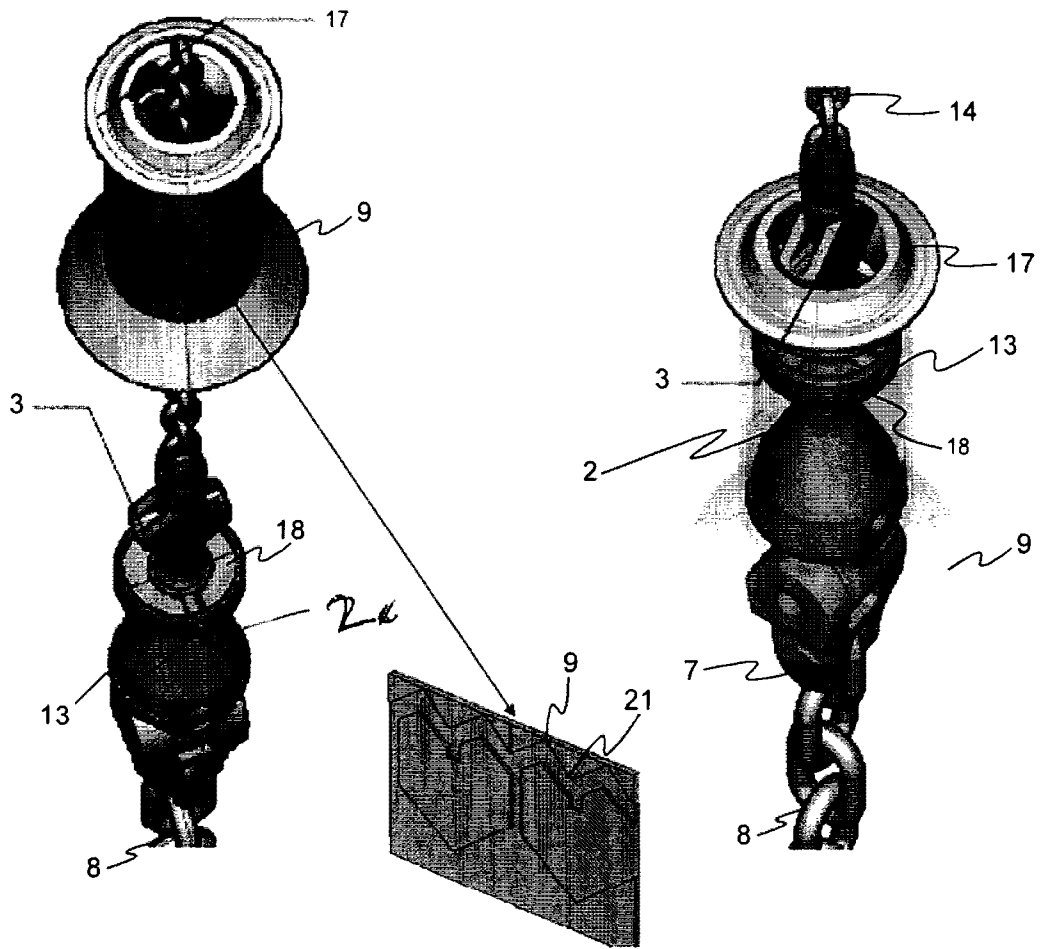

FIGURE 4

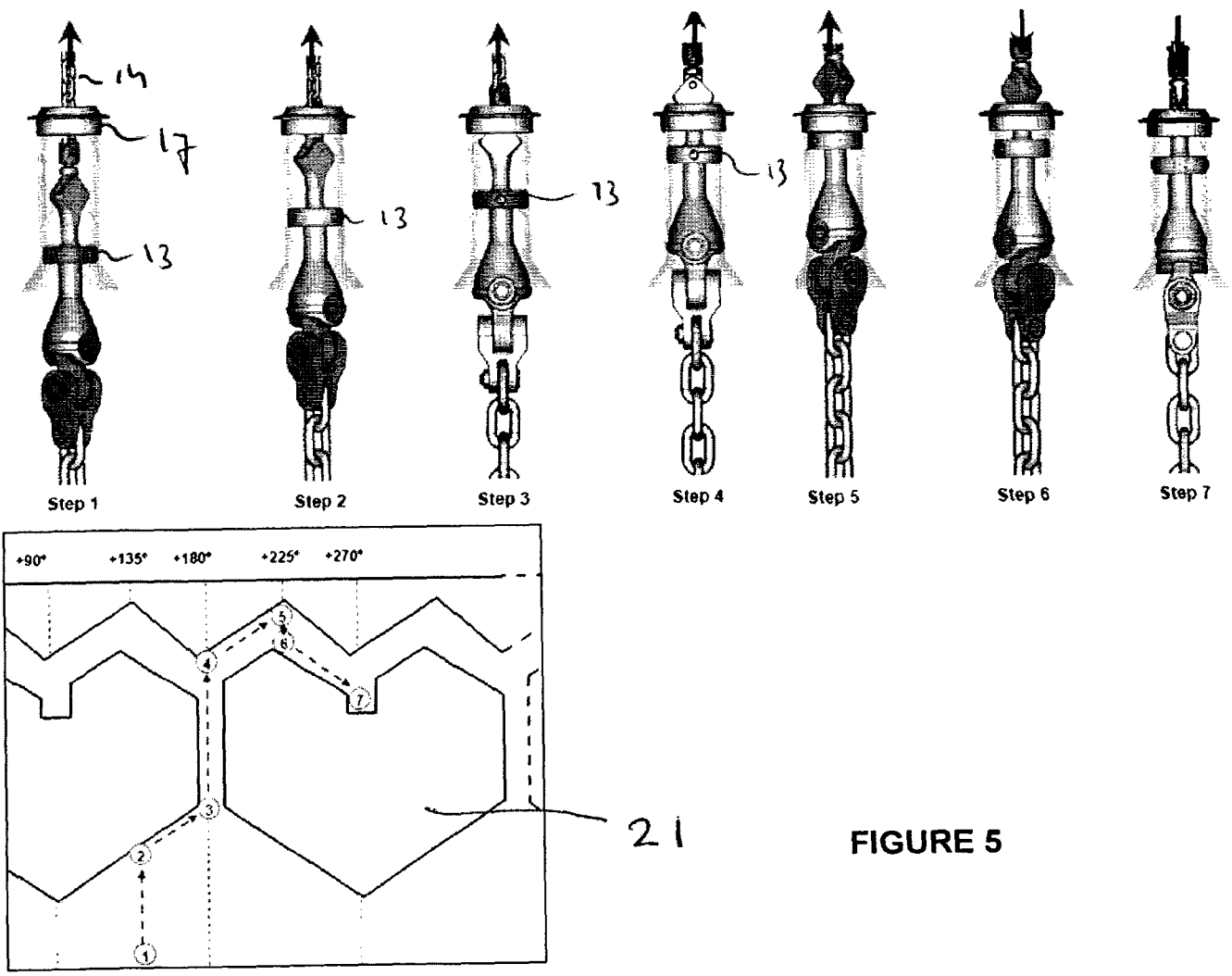

FIGURE 5

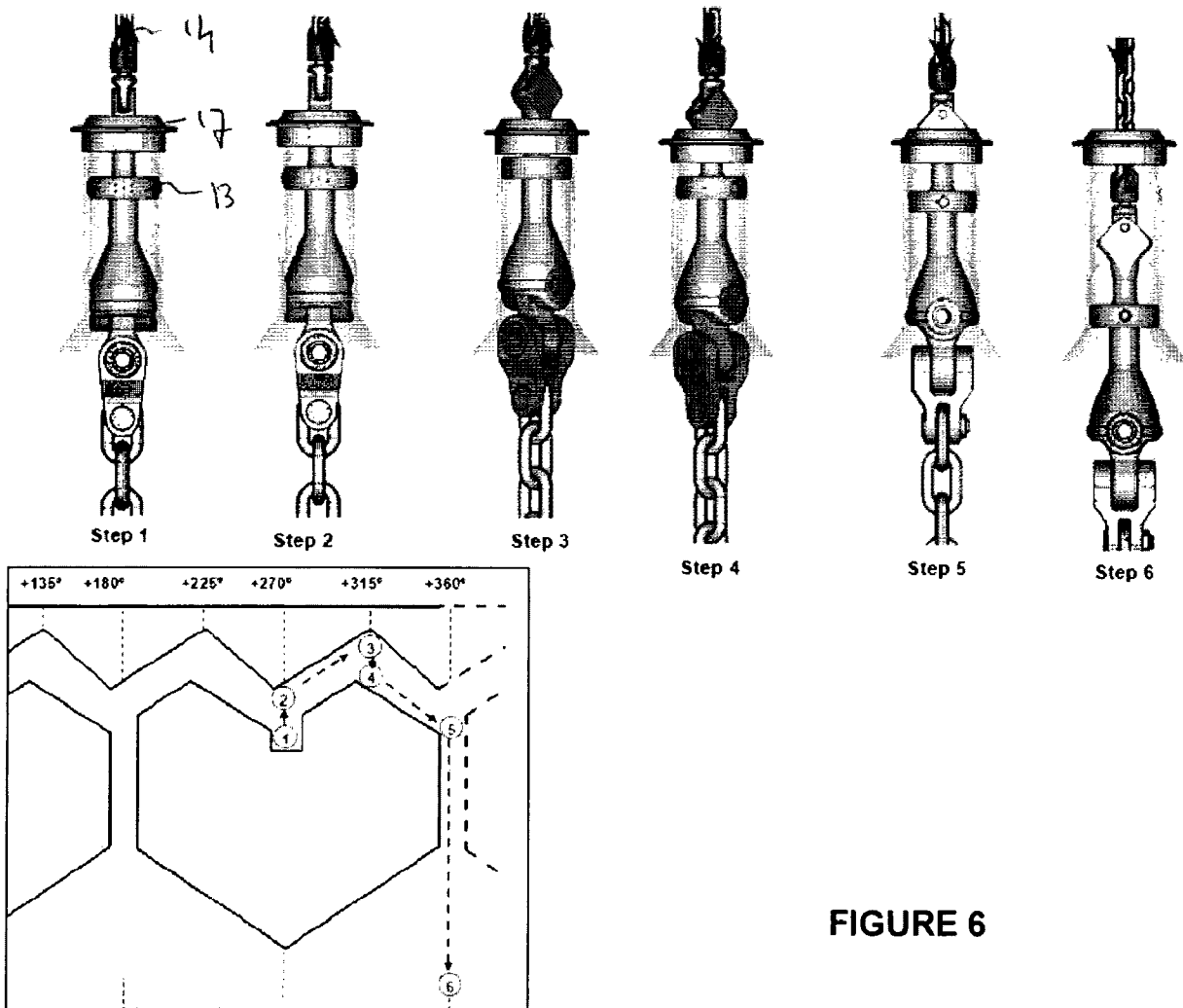

FIGURE 6

INTERNATIONAL SEARCH REPORT

International application No
PCT/EP2010/054461

A. CLASSIFICATION OF SUBJECT MATTER INV. B63B21/50 B63B22/04 ADD.		
According to International Patent Classification (IPC) or to both national classification and IPC		
B. FIELDS SEARCHED		
Minimum documentation searched (classification system followed by classification symbols) B63B B63H		
Documentation searched other than minimum documentation to the extent that such documents are included in the fields searched		
Electronic data base consulted during the international search (name of data base and, where practical, search terms used) EPO-Internal		
C. DOCUMENTS CONSIDERED TO BE RELEVANT		
Category*	Citation of document, with indication, where appropriate, of the relevant passages	Relevant to claim No.
X	US 2006/070741 A1 (POLLACK JACK [US] ET AL) 6 April 2006 (2006-04-06) figures 1-6	1-17
X	-----	
X	GB 2 178 101 A (HUNTING OILFIELD SERVICES LTD) 4 February 1987 (1987-02-04) figures 1-4	1-17
X,P	-----	
X	WO 2009/156639 A1 (TECHNIP FRANCE [FR]; ROUTEAU SYLVAIN [FR]; DE KERDANET TEGWEN [FR]) 30 December 2009 (2009-12-30) figures 1-5	1-17
X	-----	
A	US 4 943 188 A (PEPPEL GEORGE W [US]) 24 July 1990 (1990-07-24) figures 1-7	16,17 1,11,12, 14

	-/--	
<input checked="" type="checkbox"/> Further documents are listed in the continuation of Box C.		
<input checked="" type="checkbox"/> See patent family annex.		
* Special categories of cited documents :		
A document defining the general state of the art which is not considered to be of particular relevance *E* earlier document but published on or after the international filing date *L* document which may throw doubts on priority claim(s) or which is cited to establish the publication date of another citation or other special reason (as specified) *O* document referring to an oral disclosure, use, exhibition or other means *P* document published prior to the international filing date but later than the priority date claimed	*T* later document published after the international filing date or priority date and not in conflict with the application but cited to understand the principle or theory underlying the invention *X* document of particular relevance; the claimed invention cannot be considered novel or cannot be considered to involve an inventive step when the document is taken alone *Y* document of particular relevance; the claimed invention cannot be considered to involve an inventive step when the document is combined with one or more other such documents, such combination being obvious to a person skilled in the art. *&* document member of the same patent family	
Date of the actual completion of the international search <p style="text-align: center; font-weight: bold;">26 July 2010</p>	Date of mailing of the international search report <p style="text-align: center; font-weight: bold;">03/08/2010</p>	
Name and mailing address of the ISA/ European Patent Office, P.B. 5818 Patentlaan 2 NL - 2280 HV Rijswijk Tel. (+31-70) 340-2040, Fax: (+31-70) 340-3016	Authorized officer <p style="text-align: center; font-weight: bold;">van Rooij, Michael</p>	

INTERNATIONAL SEARCH REPORT

International application No
PCT/EP2010/054461

C(Continuation). DOCUMENTS CONSIDERED TO BE RELEVANT		
Category*	Citation of document, with indication, where appropriate, of the relevant passages	Relevant to claim No.
X	US 6 409 428 B1 (MOOG OLIVIER [FR]) 25 June 2002 (2002-06-25)	16,17
A	figures 2,4	1,11,12, 14
X	----- WO 2008/074930 A1 (KARVER [FR]; CONNAN JEAN-PHILIPPE [FR]; CLAUSIN MARIN [FR]) 26 June 2008 (2008-06-26)	16,17
A	figures	1,11,12, 14

INTERNATIONAL SEARCH REPORT

Information on patent family members

International application No
PCT/EP2010/054461

Patent document cited in search report	Publication date	Patent family member(s)	Publication date
US 2006070741	A1	06-04-2006	AU 2005294434 A1 20-04-2006 BR PI0516552 A 09-09-2008 WO 2006041904 A1 20-04-2006
GB 2178101	A	04-02-1987	NONE
WO 2009156639	A1	30-12-2009	FR 2931867 A1 04-12-2009
US 4943188	A	24-07-1990	NONE
US 6409428	B1	25-06-2002	FR 2791316 A1 29-09-2000
WO 2008074930	A1	26-06-2008	FR 2910569 A1 27-06-2008