

(No Model.)

F. H. LIPPINCOTT.
SIRUP JAR FAUCET.

No. 526,578.

Patented Sept. 25, 1894.

Fig. 1.

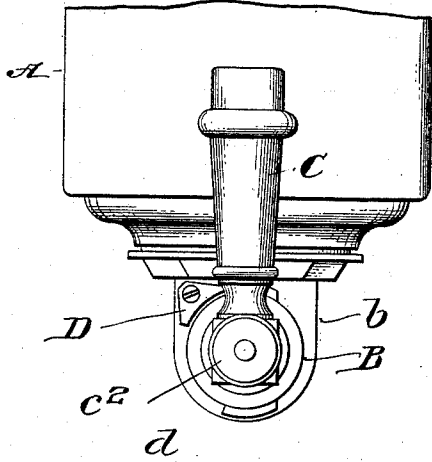

Fig. 2.

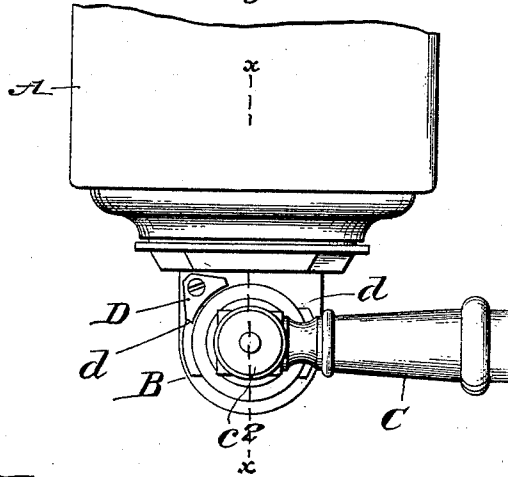

Fig. 3.

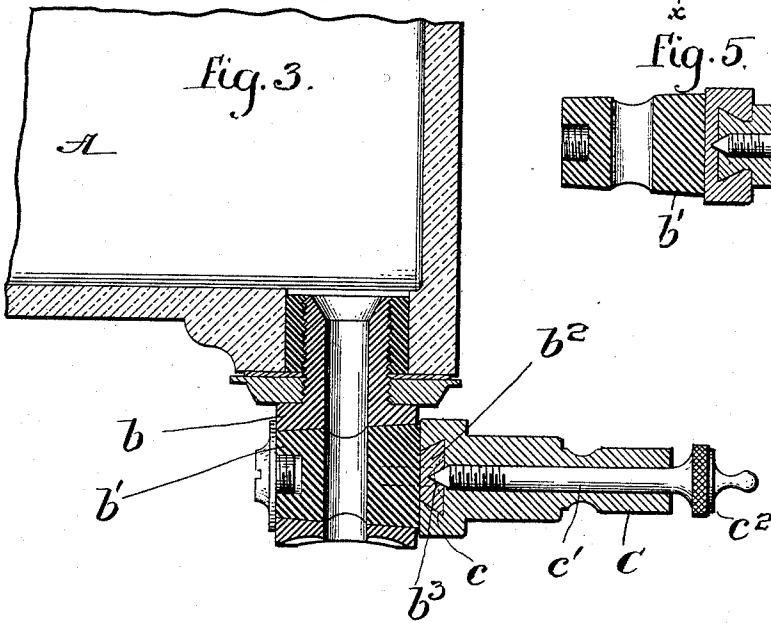

Fig. 5.

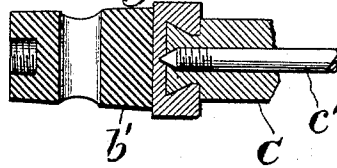
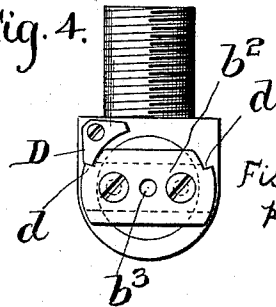

Fig. 4.



Witnesses:

Jesse B. Heller.
Ira S. Heller

Inventor.

Fisher Hazard Lippincott,
per Joshua Pusey,
Attorney.

UNITED STATES PATENT OFFICE.

FISHER HAZARD LIPPINCOTT, OF PHILADELPHIA, PENNSYLVANIA,
ASSIGNOR TO THE AMERICAN SODA-FOUNTAIN COMPANY, OF
TRENTON, NEW JERSEY.

SIRUP-JAR FAUCET.

SPECIFICATION forming part of Letters Patent No. 526,578, dated September 25, 1894.

Application filed January 15, 1894. Serial No. 496,867. (No model.)

To all whom it may concern:

Be it known that I, FISHER HAZARD LIPPINCOTT, a citizen of the United States, residing in the city and county of Philadelphia and State of Pennsylvania, have invented certain new and useful Improvements in Faucets for Sirup - Jars for Soda - Water Fountains, of which the following is a full, clear, and exact description, reference being had to the accompanying drawings, of which—

Figures 1 and 2 are elevations of the faucet, as applied to a sirup jar, the parts being shown in the closed and open positions, respectively. Fig. 3 is a vertical section, as on the line *xx* of Fig. 2. Fig. 4 is a view of the key, detached. Fig. 5 is a sectional detail of a modification hereinafter referred to.

This invention relates to an improvement in faucets of the kind used more especially in connection with the sirup jars of soda-water fountains; the improvement consisting in a simple and efficient construction by which the handle may be readily detached from, or attached to, the key, and also in certain minor features that will be hereinafter pointed out.

Referring to the annexed drawings, A marks the lower portion of a sirup jar, and B the faucet connected therewith. The body, *b*, of this faucet is of usual construction, the same being attached to, and communicating with, the interior of the jar in the ordinary way. The perforated key, *b'*, which is rotatable in this body for the purpose of opening and closing the passage in the latter, is, however, of novel construction, as shown, that is to say, it is provided on its outer end with a block or tongue, *b²*, the edges of which are preferably beveled inwardly, or dove-tailed.

C is the handle which is, in this instance, L-shaped. The free end of its horizontal member is provided with a groove *c* which being shaped correspondingly with the block, may be readily engaged with the latter. Extending longitudinally through a tapped hole in this horizontal member is a screw pin *c'* the inner end of which is adapted to be forced against the block to bind the handle thereto. The outer end of this pin is provided with a suitable head, *c²*, whereby the pin may be ma-

nipulated. Its inner end is preferably pointed, while the face of the block is provided with a socket, *b³*, into which the point may be screwed to lock the handle to the key still more effectually. By this construction it will be seen that to remove the handle from the key, it is merely requisite to unscrew the pin slightly and then detach the handle from the block; the operation being reversed, to reapply the handle.

As a simple and efficient means to determine the throw of the handle in opening and closing the key, I dispose at a suitable point on the face of the body *b*, adjacent to the key, a stop, *D*, and provide the block on its opposite ends with shoulders, *d*, that are adapted to abut against the opposed corners of the stop during the respective movements of the handle.

In Fig. 5 I have shown a modification in which the interlocking portions of the key and handle are transposed, that is to say, the block is provided with a dove-tailed groove, while the end of the handle is provided with a corresponding tongue adapted to enter said groove.

I claim—

1. In a faucet, the combination with the key, of a detachable handle therefor, one of said parts being provided with a dove-tailed or offset groove, and the other with an interlocking tongue, together with a screw clamping device, substantially as described.

2. In a faucet, the combination with the key, of a detachable handle therefor, one of said parts being provided with a groove, and the other with an interlocking tongue, together with a screw pin fitted to the handle and adapted to clamp said parts together, substantially as described.

3. In a faucet, the combination with the key provided with a dove-tailed block, or tongue, on one end thereof, of a handle provided with a dove-tailed groove adapted to receive said tongue or block, together with the screw pin fitted to the handle and adapted to bear against said block or tongue, substantially as described.

4. In a faucet, the combination with the key,

provided with a tongue or block, a handle
provided with a groove adapted to receive
said tongue or block, a screw fitted to the han-
dle and adapted to bear against the block or
5 tongue, and a fixed stop against which the
ends of said tongue or block, are adapted to
abut, substantially as described.

In testimony whereof I have hereunto af-
fixed my signature in the presence of two sub-
scribing witnesses.

FISHER HAZARD LIPPINCOTT.

Witnesses:

WALTER C. PUSEY,

JOHN R. NOLAN.