



- (51) International Patent Classification: **B60K 15/04** (2006.01)
- (21) International Application Number: PCT/US2012/039398
- (22) International Filing Date: 24 May 2012 (24.05.2012)
- (25) Filing Language: English
- (26) Publication Language: English
- (30) Priority Data: 13/114,140 24 May 2011 (24.05.2011) US
- (71) Applicant (for all designated States except US): **EATON CORPORATION** [US/US]; 1111 Superior Avenue, Cleveland, OH 44114 (US).
- (72) Inventor; and
- (75) Inventor/Applicant (for US only): **WALKOWSKI, Paul, D.** [US/US]; 338 Manor Drive, Ann Arbor, MI 48105 (US).
- (74) Agents: **SHIH, Anna, M.** et al.; Dykema Gossett PLLC, 39577 Woodward Avenue, Suite 300, Bloomfield Hills, MI 48304 (US).
- (81) Designated States (unless otherwise indicated, for every kind of national protection available): AE, AG, AL, AM, AO, AT, AU, AZ, BA, BB, BG, BH, BR, BW, BY, BZ, CA, CH, CL, CN, CO, CR, CU, CZ, DE, DK, DM, DO, DZ, EC, EE, EG, ES, FI, GB, GD, GE, GH, GM, GT, HN, HR, HU, ID, IL, IN, IS, JP, KE, KG, KM, KN, KP, KR, KZ, LA, LC, LK, LR, LS, LT, LU, LY, MA, MD, ME, MG, MK, MN, MW, MX, MY, MZ, NA, NG, NI, NO, NZ, OM, PE, PG, PH, PL, PT, QA, RO, RS, RU, RW, SC, SD, SE, SG, SK, SL, SM, ST, SV, SY, TH, TJ, TM, TN, TR, TT, TZ, UA, UG, US, UZ, VC, VN, ZA, ZM, ZW.
- (84) Designated States (unless otherwise indicated, for every kind of regional protection available): ARIPO (BW, GH, GM, KE, LR, LS, MW, MZ, NA, RW, SD, SL, SZ, TZ, UG, ZM, ZW), Eurasian (AM, AZ, BY, KG, KZ, RU, TJ, TM), European (AL, AT, BE, BG, CH, CY, CZ, DE, DK, EE, ES, FI, FR, GB, GR, HR, HU, IE, IS, IT, LT, LU, LV, MC, MK, MT, NL, NO, PL, PT, RO, RS, SE, SI, SK, SM,

[Continued on next page]

(54) Title: FUEL INLET VALVE WITH INTEGRAL LINE

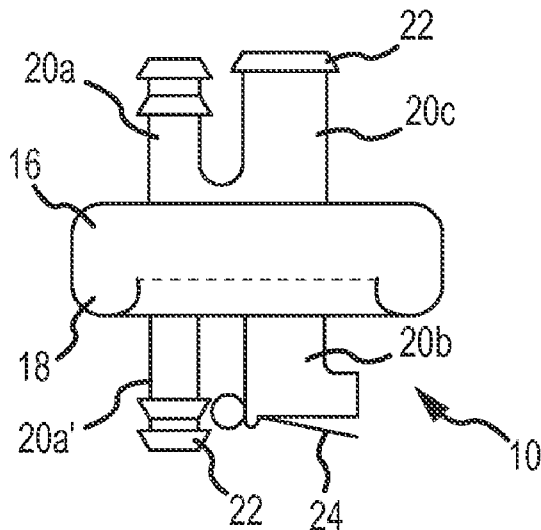

FIG. 1B

(57) Abstract: A fuel inlet valve (10) for a fuel tank includes a flange (16) that is attachable to the fuel tank and a first aperture and a second aperture formed in the flange. The fuel inlet valve (10) also includes a fuel valve (20b) associated with the first aperture and a fill pipe nipple (20c) associated with the first aperture. The fuel valve (10) and the fill pipe nipple (20c) form a fuel path through the first aperture. The fuel inlet valve (10) also has at least one nipple (20a) associated with the second aperture and connectable to said at least one nipple (20a) is connectable to a purge line, a fuel pump, or a fuel line.

WO 2012/162532 A1

TR), OAPI (BF, BJ, CF, CG, CI, CM, GA, GN, GQ, GW, ML, MR, NE, SN, TD, TG). **Published:**

— with international search report (Art. 21(3))

FUEL INLET VALVE WITH INTEGRAL LINE

TECHNICAL FIELD

[0001] The present invention relates to a fuel inlet valve that covers an opening in a fuel tank, and more particularly to a fuel inlet valve containing multiple apertures associated with components in a fuel emissions system.

BACKGROUND OF THE INVENTION

[0002] A vehicle fuel emissions system may include multiple components, such as valves, disposed inside a fuel tank and vented outside the tank through corresponding apertures through the fuel tank. The fuel tank may also include additional apertures corresponding to, for example, fuel lines, purge nipples, ports, and other system components.

[0003] To minimize emissions, the system should have a low level of permeability to both liquid fuel and fuel vapor. Each opening, or "penetration," formed in the fuel tank to accommodate the apertures also creates a permeation path, and the permeability of the fuel tank increases as the number of permeation paths increase. Thus, it is desirable to reduce the number of fuel tank penetrations, especially in view of the particularly strict emissions requirements for Partial Zero Emissions Vehicles (PZEV) and Ultra Low Emissions Vehicles (ULEV). On the other hand, there still needs to be a sufficient number of fuel tank penetrations to accommodate all of the apertures needed to link the fuel tank with the other components in the emissions system.

[0004] There is a desire for an arrangement that can provide multiple apertures to accommodate multiple components in the fuel system without increasing the permeability of the fuel tank.

SUMMARY OF THE INVENTION

[0005] A fuel inlet valve for a fuel tank according to one embodiment may include a flange that is attachable to the fuel tank and a first aperture and a second aperture formed in the flange. The inlet valve may also include a fuel valve associated with the first aperture and a fill pipe nipple associated with the first aperture. The fuel valve and the fill pipe nipple may form a fuel path through the first aperture. The inlet valve may also have at least one

nipple associated with the second aperture and connectable to said at least one nipple is connectable to a purge line, a fuel pump, or a fuel line.

[0006] A fuel inlet valve for a fuel tank according to another embodiment may include a flange that is attachable to the fuel tank and an aperture formed in the flange. A fuel valve and a fill pipe nipple may both be associated with the first aperture to form a fuel path through the first aperture. The inlet valve may also include at least one purge nipple extending at an angle from a base of the fuel pipe nipple.

BRIEF DESCRIPTION OF THE DRAWINGS

[0007] Figures 1A and 1B are top and side views, respectively, of a fuel inlet valve according to one embodiment of the invention;

[0008] Figures 2A and 2B are top and side views, respectively, of a fuel inlet valve according to another embodiment of the invention;

[0009] Figures 3A and 3B are top and side views, respectively, of a fuel inlet valve according to yet another embodiment of the invention;

[0010] Figures 4A and 4B are top and side views, respectively, of a fuel inlet valve according to a further embodiment of the invention.

DETAILED DESCRIPTION OF THE INVENTION

[0011] Figures 1A and 1B illustrate a fuel inlet valve 10 according to one embodiment of the invention. The inlet valve 10 covers an opening or penetration in a fuel tank (not shown). The opening forms a permeation path that is closed by the inlet valve 10 to block the passage of liquid fuel and fuel vapor through the opening. The inlet valve 10 acts as an attachment point for fuel emissions system components, including but not limited to fuel lines, valves, and purge nipples. In the examples described below, the inlet valve 10 will be described with respect to an in-line check valve (ICV), a purge nipple, and a fuel line, but those of ordinary skill in the art will understand that the inlet valve 10 can connect with any other component in the fuel emissions system without departing from the scope of the invention.

[0012] The inlet valve 10 of Figures 1A and 1B has a flange 16 that attaches to the fuel tank through any known means, such as through welding, chemical bonding, mechanical interlocking, or adhesive. The inlet valve 10 may be configured to be either permanently attached to the fuel tank (*e.g.*, through welding) or removably attached to the fuel tank (*e.g.*, through mechanical interlocking). An optional weld foot 18 may be formed on the flange 16 to aid connection between the inlet valve 10 and the fuel tank. The specific material used to make the flange 16 may depend on the type of fuel tank that the inlet valve 10 will attach to. For example, the flange 16 may be made of a plastic that can be attached to a plastic fuel tank. Alternatively, flange 16 may be cast from metal so that it can easily attached to a metal fuel tank.

[0013] The flange 16 may have any appropriate shape, such as a round or oval shape, depending on the configuration of other elements in the inlet valve 10 as described in greater detail below.

[0014] In the embodiment shown in Figures 1A and 1B, the flange 16 may have two apertures, one associated with one or more purge nipples 20a, 20a' and another associated with an in-line check valve (ICV) 20b. The inlet valve 10 may include two purge nipples 20a aligned with each other, with one purge nipple 20a to be disposed inside the fuel tank and another purge nipple 20a' to be disposed outside the fuel tank. The purge nipples 20a, 20a' may have one more barbs 22 to provide a secure connection with a purge line (not shown).

[0015] The ICV 20b may have or be associated with a fill pipe nipple 20c to allow connection of a fill pipe (not shown). In this embodiment, the ICV 20b is also connected to the fuel line nipple 20c disposed outside the tank, thereby creating a fuel path. The fill pipe nipple 20c may also have an associated barb 22 to provide a more secure connection. The ICV 20b itself may have any configuration that allows it to act as a check valve. The ICV 20b shown in the Figures includes a flapper 24 to be disposed inside the fuel tank, but the ICV 20b may have other closure mechanisms without departing from the scope of the invention.

[0016] Since the purge nipples 20a, 20a' and the ICV 20b are both disposed in the same flange 16, the flange 16 provides two apertures associated with three elements (*i.e.*, the purge nipples 20a, 20a', the ICV 20b, and the fill pipe nipple 20c) while allowing only one

opening/penetration 16 in the fuel tank. As a result, the inlet valve 10 provides multiple apertures through the fuel tank without increasing the number of fuel tank openings 16 that could increase the permeability of the fuel tank.

[0017] Figures 2A and 2B illustrate another embodiment of the inventive inlet valve 10. In this embodiment, the flange 16 has an additional aperture corresponding to two fuel line nipples 20d, 20d' that provide a connection to a fuel pump (not shown) inside the fuel tank and a fuel delivery line (not shown) outside the fuel tank. A quick connect fitting 26 may be included on at least one of the fuel line nipples 20d, 20d'. In this embodiment, purge nipples 20a, 20a', the ICV 20b and fill pipe nipple 20c, and the fuel line nipples 20d, 20d' may be arranged so that the centers of their corresponding apertures are aligned with each other along a line A. To accommodate this orientation, the flange 16 may have an oval shape as shown in Figures 2A and 2B, but other aperture orientations and flange shapes may be used without departing from the scope of the invention. For example, as shown in Figures 3A and 3B, the centers of the apertures corresponding to the purge nipples 20a, 20a', the ICV 20b and fill pipe nipple 20c, and the fuel line nipples 20d, 20d' are arranged in a triangular pattern and the flange may have a circular shape, creating a more compact footprint.

[0018] Figures 4A and 4B illustrate a further embodiment of the inventive inlet valve 10. In this embodiment, the ICV 20b is oversized so that the cross-section of the ICV 20b is also large enough to allow adequate flow during refueling. In this embodiment, the ICV 20b is also connected to the fuel line nipple 20c disposed outside the tank, thereby creating a single fuel path like in the other embodiments. Also, in this embodiment, the purge nipples 20a, 20a' are angled and extend from the base of the fill pipe nipple 20c. The angle may be selected to still allow enough room to easily connect hoses or other components to the purge nipples 20a, 20a'. In one embodiment, the purge nipples 20a, 20a' extend from the base of the fuel line nipple 20c at approximately a 45-degree angle.

[0019] Note that although the embodiment of Figures 4A and 4B does not show fuel line nipples 20d, 20d', they may also be included in this embodiment without departing from the scope of the invention. Also, the flange 16 in this embodiment may have only one aperture that is shared by the ICV 20b, the fuel line nipple 20c, and the purge nipples 20a, 20a'. Alternatively, the flange 16 may have more than one opening like the other embodiments to accommodate the ICV 20b, the fuel line nipple 20c, and the purge nipples 20a, 20a'.

[0020] The purge nipples 20a, 20a' together may form an elbow 28, creating a curved purge path. A portion of the elbow 28 may extend into the fuel path formed by the ICV 20b and the fill pipe nipple 20c, as shown in Figure 4A. By disposing both the ICV 20b and the fuel line nipple 20c in the same fuel path and angling the purge nipples 20a, 20a' from the base of the fill pipe nipple 20c, the flange 16 can be even smaller than the flange 16 in the other embodiments. Moreover, this embodiment provides multiple apertures while using minimum number of fuel tank penetrations, thereby minimizing the permeability of the inlet valve 10 and thus the overall emissions system.

[0021] While the best modes for carrying out the invention have been described in detail, those familiar with the art to which this invention relates will recognize various alternative designs and embodiments for practicing the invention within the scope of the appended claims.

WHAT IS CLAIMED IS:

1. A fuel inlet valve for a fuel tank, comprising:
a flange configured to be attachable to the fuel tank;
a first aperture and a second aperture formed in the flange;
5 a fuel valve associated with the first aperture;
a fill pipe nipple associated with the first aperture, wherein the fuel valve and
the fill pipe nipple form a fuel path through the first aperture; and
at least one nipple associated with the second aperture.
- 10 2. The fuel inlet valve of claim 1, wherein said at least one nipple is connectable
to at least one of a purge line, a fuel pump, and a fuel line.
3. The fuel inlet valve of claim 1, wherein said at least one nipple includes first
and second purge nipples connectable with a purge line, wherein the first purge nipple is
disposed inside the fuel tank and the second purge nipple is disposed outside the fuel tank.
- 15 4. The fuel inlet valve of claim 3, wherein the first and second purge nipples
meet at a base of the fuel pipe nipple to form an elbow.
5. The fuel inlet valve of claim 4, wherein the elbow is disposed in a portion of
the fuel path between the fuel valve and the fill pipe nipple.
6. The fuel inlet valve of claim 1, wherein said at least one nipple comprises a
fuel line nipple.
- 20 7. The fuel inlet valve of claim 1, further comprising at least one barb disposed
on at least one nipple.
8. The fuel inlet valve of claim 1, further comprising at least one quick connect
fitting disposed on at least one nipple.

9. The fuel inlet valve of claim 1, further comprising a third aperture,
wherein said at least one nipple associated with the second aperture includes
first and second purge nipples connectable with the purge line, wherein the first purge nipple
is disposed inside the fuel tank and the second purge nipple is disposed outside the fuel tank,
5 and
further comprising a fuel line nipple associated with the third aperture.
10. The fuel inlet valve of claim 9, wherein the first, second, and third apertures
each have a center, and wherein the centers of the first, second, and third apertures are
disposed along a line.
- 10 11. The fuel inlet valve of claim 9, wherein the first, second, and third apertures
each have a center, and wherein the centers of the first, second, and third apertures are
disposed in a triangle.
12. A fuel inlet valve for a fuel tank, comprising:
a flange configured to be attachable to the fuel tank;
15 an aperture formed in the flange;
a fuel valve associated with the first aperture;
a fill pipe nipple associated with the first aperture, wherein the fuel valve and
the fill pipe nipple form a fuel path through the first aperture; and
at least one purge nipple associated with the first aperture, wherein said at
20 least one purge nipple extends at an angle from a base of the fuel pipe nipple.
13. The fuel inlet valve of claim 12, wherein said at least one purge nipple
comprises first and second purge nipples, and wherein the first and second purge nipples
meet at the base of the fuel pipe nipple to form an elbow.
14. The fuel inlet valve of claim 13, wherein the elbow extends into a portion of
25 the fuel path between the fuel valve and the fill pipe nipple.

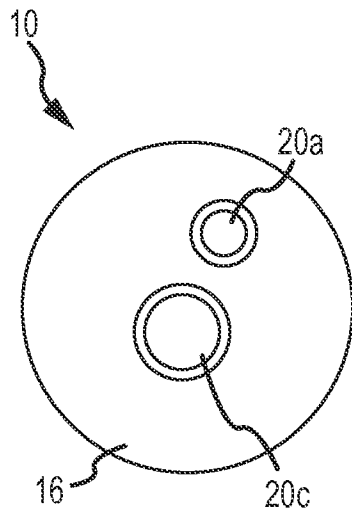

FIG. 1A

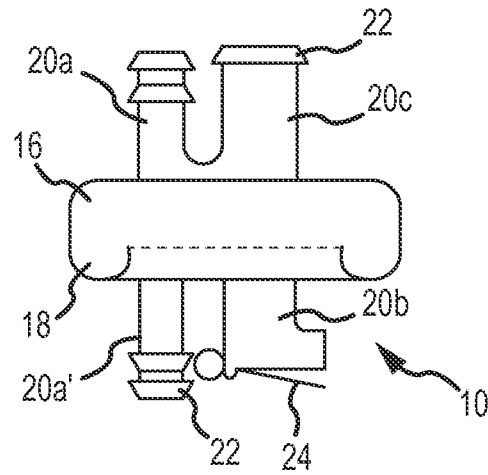

FIG. 1B

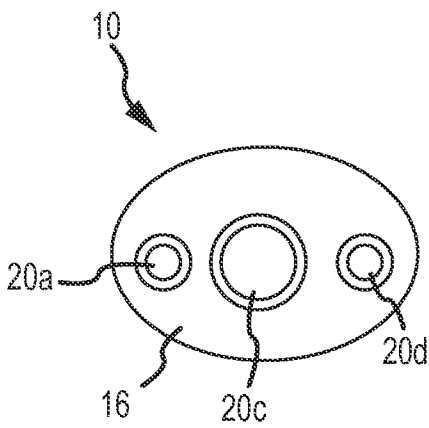

FIG. 2A

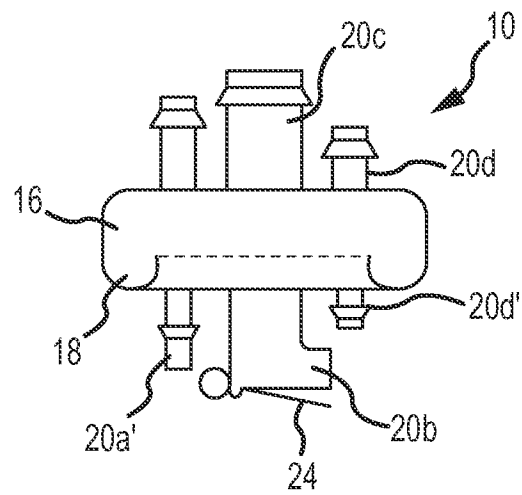

FIG. 2B

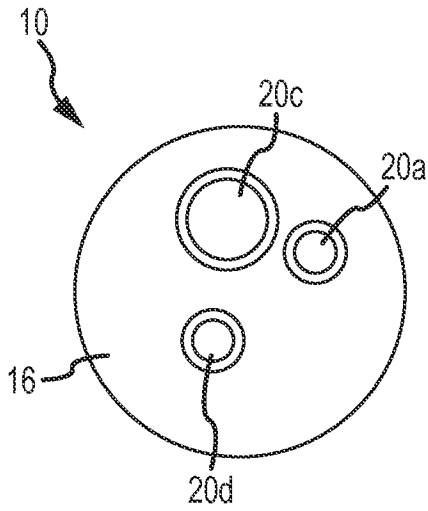

FIG. 3A

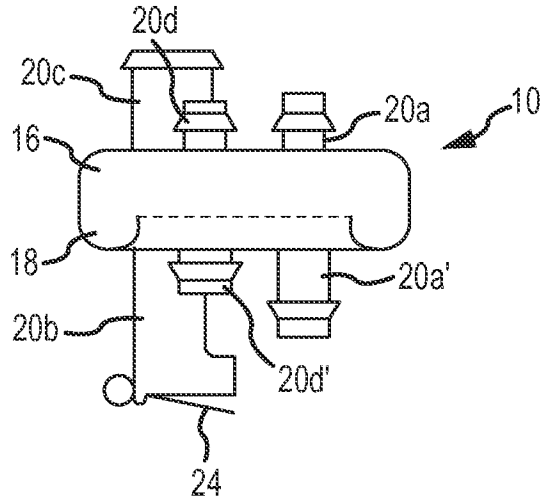

FIG. 3B

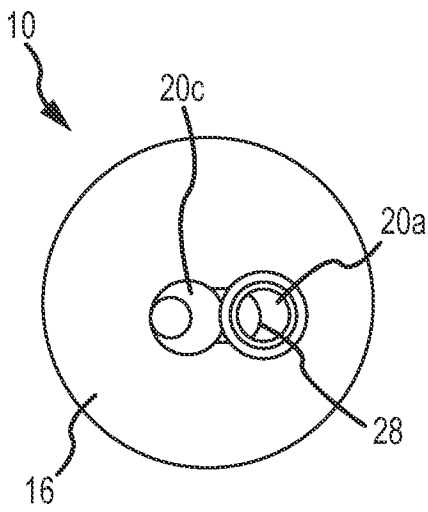

FIG. 4A

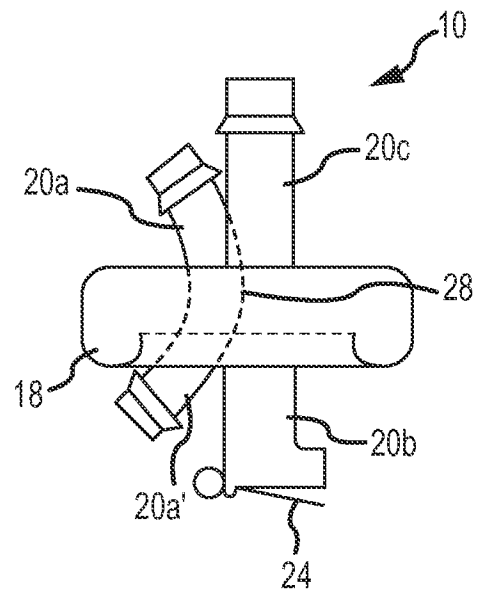

FIG. 4B

INTERNATIONAL SEARCH REPORT

International application No PCT/US2012/039398

A. CLASSIFICATION OF SUBJECT MATTER
 INV. B60K15/04
 ADD.

According to International Patent Classification (IPC) or to both national classification and IPC

B. FIELDS SEARCHED

Minimum documentation searched (classification system followed by classification symbols)
 B60K

Documentation searched other than minimum documentation to the extent that such documents are included in the fields searched

Electronic data base consulted during the international search (name of data base and, where practicable, search terms used)

EPO-Internal, WPI Data

C. DOCUMENTS CONSIDERED TO BE RELEVANT

Category*	Citation of document, with indication, where appropriate, of the relevant passages	Relevant to claim No.
Y	US 6 234 195 B1 (KIPPE BRADLEY N [US] ET AL) 22 May 2001 (2001-05-22) abstract; figure 6 -----	1, 12
Y	US 5 960 816 A (MILLS VAUGHN [US] ET AL) 5 October 1999 (1999-10-05) abstract; figure 5 -----	1, 12
Y	EP 1 122 114 A2 (STANT MFG INC [US]) 8 August 2001 (2001-08-08) abstract; figure 2 -----	1, 12

Further documents are listed in the continuation of Box C.

See patent family annex.

* Special categories of cited documents :

"A" document defining the general state of the art which is not considered to be of particular relevance

"E" earlier application or patent but published on or after the international filing date

"L" document which may throw doubts on priority claim(s) or which is cited to establish the publication date of another citation or other special reason (as specified)

"O" document referring to an oral disclosure, use, exhibition or other means

"P" document published prior to the international filing date but later than the priority date claimed

"T" later document published after the international filing date or priority date and not in conflict with the application but cited to understand the principle or theory underlying the invention

"X" document of particular relevance; the claimed invention cannot be considered novel or cannot be considered to involve an inventive step when the document is taken alone

"Y" document of particular relevance; the claimed invention cannot be considered to involve an inventive step when the document is combined with one or more other such documents, such combination being obvious to a person skilled in the art

"&" document member of the same patent family

Date of the actual completion of the international search

31 August 2012

Date of mailing of the international search report

11/09/2012

Name and mailing address of the ISA/

European Patent Office, P.B. 5818 Patentlaan 2
 NL - 2280 HV Rijswijk
 Tel. (+31-70) 340-2040,
 Fax: (+31-70) 340-3016

Authorized officer

Eriksson, Jonas

INTERNATIONAL SEARCH REPORT

Information on patent family members

International application No PCT/US2012/039398

Patent document cited in search report	Publication date	Patent family member(s)	Publication date
US 6234195	B1	22-05-2001	NONE
US 5960816	A	05-10-1999	NONE
EP 1122114	A2	08-08-2001	CA 2334149 A1 03-08-2001
			EP 1122114 A2 08-08-2001
			US 6422261 B1 23-07-2002