



(12) **EUROPEAN PATENT APPLICATION**

(43) Date of publication:
27.04.2005 Bulletin 2005/17

(51) Int Cl.7: **E04H 1/12**

(21) Application number: **03024316.6**

(22) Date of filing: **24.10.2003**

(84) Designated Contracting States:
**AT BE BG CH CY CZ DE DK EE ES FI FR GB GR
HU IE IT LI LU MC NL PT RO SE SI SK TR**
Designated Extension States:
AL LT LV MK

(72) Inventor: **Valenti, Franco**
00144 Rome (IT)

(74) Representative: **Hyltner, Jan-Olof et al**
Albihns Stockholm AB,
Box 5581
114 85 Stockholm (SE)

(71) Applicant: **Emerson Energy Systems AB**
141 82 Stockholm (SE)

(54) **Telecommunication cabinet**

(57) The present invention relates to a cabinet (10) for holding telecommunication related equipment, wherein the cabinet (10) comprises a plurality of sepa-

rate cabinet modules (16-26), which are mutually connectable on top of each other so as to form a vertically erected cabinet (10).

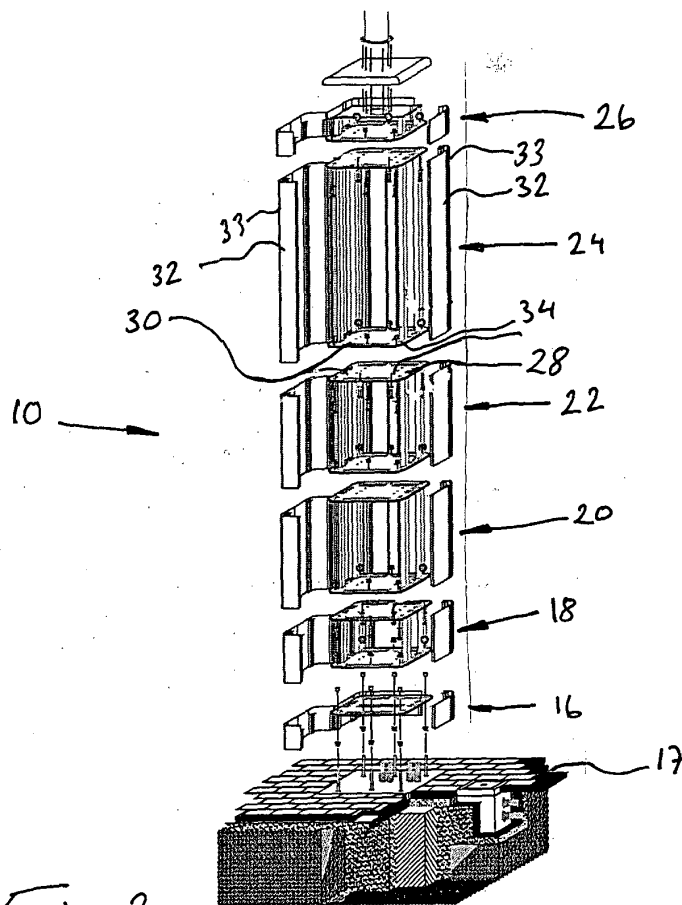

Fig. 3

Description

TECHNICAL FIELD

[0001] The present invention relates to a cabinet in accordance with the preamble of claim 1.

BACKGROUND OF THE INVENTION

[0002] Telecommunication equipment is normally held in cabinets, which give shelter from wind, rain, snow, etc, and keep people without authorisation away. Not only telecommunication equipment is held in such cabinets, but also other equipment which is related to the telecommunication equipment, such as cooling equipment, distribution equipment, battery back-up equipment and power supply equipment, which from obvious reasons are required for the function of the telecommunication equipment. The equipment is normally arranged in racks of fixed dimensions within the cabinets and thus need to share the existing space defined by these racks.

[0003] However, when the equipment within the cabinet is to be upgraded, or need to be replaced by equipment from a different supplier, or if additional equipment is required, problems may arise if the existing space defined by the racks is limited.

[0004] A solution to this problem is to arrange yet a cabinet next to the first cabinet, and in which the upgrading/replacing/additional equipment is placed. However, such horizontal cabinet clustering is expensive and takes up a great deal of space, which can be disadvantageous, e.g. when the cabinet is located in densely built-up areas, and furthermore requires that the ground, where the cabinet is to be mounted, is extensively prepared.

OBJECT OF THE INVENTION

[0005] An object of the present invention is to provide a cabinet which is independent of equipment upgrade and/or equipment replacement.

[0006] A further object of the present invention is to provide a cabinet which is space-saving.

[0007] Yet an object of the present invention is to provide a cabinet which easily can be assembled at any location.

SUMMARY OF THE INVENTION

[0008] These objects are achieved by means of a cabinet having the features according to the characterising portion of claim 1. Hereby is achieved a flexible way of building telecommunication cabinets, since the chosen number of cabinet modules is adapted to the required amount of telecommunication related equipment.

[0009] Furthermore, since the cabinet modules are mutually connectable on top of each other, the cabinet

modules can be stacked in a vertical direction. Hereby is achieved that cabinets with small cross-sections can be designed, and that horizontally extended, space requiring cabinet clusters are avoided.

[0010] Moreover, the modularity also promote allocation of telecommunication related equipment, such as telecommunication equipment, cooling equipment, distribution equipment, battery back-up equipment and power supply equipment to specific cabinet modules. Due to this equipment allocation possibility, equipment supplier independence, equipment replacement independence as well as upgrade independence are achieved. For example, a specific cabinet module can be prepared, in advance, with appropriate equipment before replacing the "old" cabinet module on site. In addition, the modularity also makes it possible to change the configuration of the cabinet on site at a very late stage of the cabinet assembly process.

[0011] Preferably, said cabinet modules comprise a common mechanical interface for mutual connection of said cabinet modules. Hereby is achieved that the cabinet modules can be mounted independently of their vertical size.

[0012] Suitably, said mechanical interface comprises means for removably connecting two adjacent cabinet modules. Hereby is achieved easy assembly as well as disassembly in case of replacement or upgrade of existing telecommunication related equipment.

[0013] Preferably, said cabinet modules have substantially flat side surfaces with bevelled comers. Hereby the surfaces of the cabinet can easily be used for, e.g. advertising messages or other type of public information. Since the cabinet is stackable in a vertical direction and is provided with the flat side surfaces, deliberate damages to the cabinet is made more difficult.

[0014] Suitably, said cabinet modules can be of different size. Hereby is further flexibility achieved.

BRIEF DESCRIPTION OF THE DRAWINGS

[0015] Preferred embodiments will now be described by way of example and with reference to accompanying drawings, on which:

Fig. 1a-c show a lateral and two front views, respectively of a cabinet according to the present invention;

Fig. 2 shows the cabinet of fig. 1 in a different application;

Fig. 3 shows cabinet modules intended for the cabinet in fig. 1-2;

Fig. 4a-b show various ways of vertically stacking the cabinet modules.

DETAILED DESCRIPTION OF PREFERRED EMBODIMENTS

[0016] Fig. 1a-c show a cabinet 10 in accordance with a preferred embodiment of the present invention and is mounted on the ground, on e.g. a concrete slab.

[0017] The cabinet 10 is adapted to hold telecommunication equipment as well as other equipment which is necessary for the function of the telecommunication equipment, such as cooling, distribution, battery back-up and power supply equipment. The cabinet 10 comprises, in this embodiment, six cabinet modules made of sheet metal (which are more thoroughly explained in connection with fig. 3), which are stacked on top of each other, so as to form the cabinet. In fig. 1a, covers 12 belonging to a specific cabinet module have been partly removed, wherein the equipment contained in each cabinet module is exposed. An advertising sign 14 is mounted on top of the cabinet. The cabinet is suitable for both indoor and outdoor use.

[0018] In fig. 1c an antenna 15 is arranged on top of the cabinet, but it is also possible to arrange other devices on top of the cabinet, such as clocks, illuminated advertising devices, television displays, etc, especially if the cabinet is to be placed in an urban environment.

[0019] In fig. 2 the cabinet 10 is instead situated on a railway station platform, where it also functions as a post for a roof structure.

[0020] Fig. 3 shows an exploded view of the six cabinet modules 16-26 of fig. 1-2. These modules are stacked on top of each other and thus form a vertically erected cabinet. Each cabinet module 16-26 has a substantially square cross-section and comprises an upper surface 28, a lower surface 30 and four side surfaces 32 (of which only two are shown of clarity reasons). Corners 33 which connect two adjacent side surfaces are somewhat bevelled or rounded, which facilitate pasting of advertising posters up on the side surfaces 32 when the cabinet is used in, e.g. an urban environment.

[0021] The cabinet modules 16-26 are provided with a mechanical interface 34 in the form of mutually aligned bore holes 34 disposed in the upper and the lower surfaces of each cabinet module, respectively, in combination with screw joints 34 to firmly connect the cabinet modules 16-26, and to provide a removable connection between the cabinet modules. This mechanical interface is of clarity reasons only depicted on the lower surface 30 of the cabinet module 22 and on the upper surface 28 of the cabinet module 20, but the other cabinet modules are of course also provided with a corresponding mechanical interface.

[0022] Fig. 4a-b show two further embodiments of vertically stacked cabinet modules. The configuration depends on application, and other configurations than those depicted are conceivable, e.g. more or less cabinet modules.

[0023] From fig. 3-4 it is also apparent that the mod-

ules are of different height, which in the present embodiments are standardised and depicted in relative dimensions. Four sizes are shown: a L-module, i.e. a cabinet module of height L; a L/2-module; a L/4-module and a L/8-module. These four cabinet module types can be combined in a variety of combinations. In fig. 4a, two L/8-modules, a L-module and a L/4-module are stacked on top of each other, while in fig. 4b an extra L/4-module and a L/2-module are included in the stack of modules. In the latter case, perhaps extra cooling and battery back-up was required (compared to the configuration shown in fig. 4a) and from that reason the extra L/4-module and the L/2-module containing such equipment was included in the cabinet stack.

[0024] Each cabinet module size L, L/2, L/4 can hold any type of the telecommunication related equipment specified above, e.g. telecommunication, cooling, distribution, battery back-up or power supply equipment, but the cabinet modules can of course contain any other accessory equipment which is necessary for the function of the telecommunication equipment. The L/8-modules are not intended to contain any equipment, but are only used as top and bottom modules for sealing and support purposes.

[0025] Thus, solely the current application will determine the number of cabinet modules, the size of the chosen cabinet modules and what kind of equipment to be put in which cabinet module. Accordingly, the present invention provides a modular cabinet with full flexibility regarding the number of modules, modular size as well as equipment choice.

[0026] Even if not depicted in the drawings the cabinet modules 16-26 are provided with appropriate through-holes to facilitate cabling between adjacent cabinet modules and provide space for ventilating ducts, etc.

[0027] In stead of the covers 12 shown in connection with fig. 1a, it is of course conceivable to use, e.g. hinged doors or any other suitable means for opening/closing the cabinet.

[0028] The present invention is not restricted to the four different cabinet modules shown above, but the number of different cabinet modules can be extended to, e.g. a 3/2L-module, a 2L-module, and a L/6-module, and so on.

Claims

1. Cabinet (10) for holding telecommunication related equipment, **characterised in that** said cabinet comprises a plurality of separate cabinet modules (16-26), which are mutually connectable on top of each other so as to form a vertically erected cabinet (10).
2. Cabinet according to claim 1, wherein said cabinet modules (16-26) comprise a common mechanical interface (34) for mutual connection of said cabinet

modules.

3. Cabinet according to claim 2, wherein said mechanical interface (34) comprises means for removably connecting two adjacent cabinet modules (16-26). 5
4. Cabinet according to any of the previous claims, wherein said cabinet modules (16-26) have substantially flat side surfaces (32) with bevelled comers (33). 10
5. Cabinet according to any of the previous claims, wherein said cabinet modules (16-26) can be of different size. 15

20

25

30

35

40

45

50

55

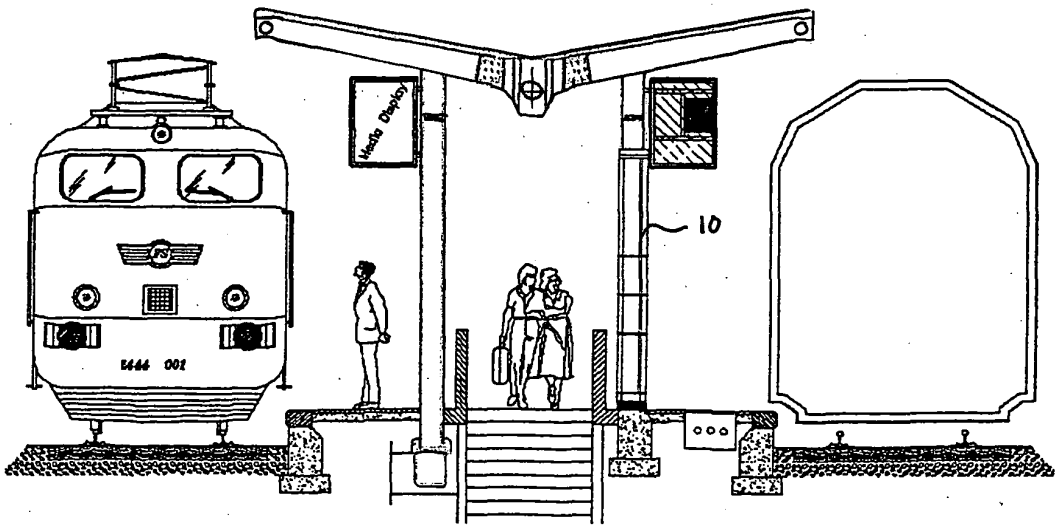
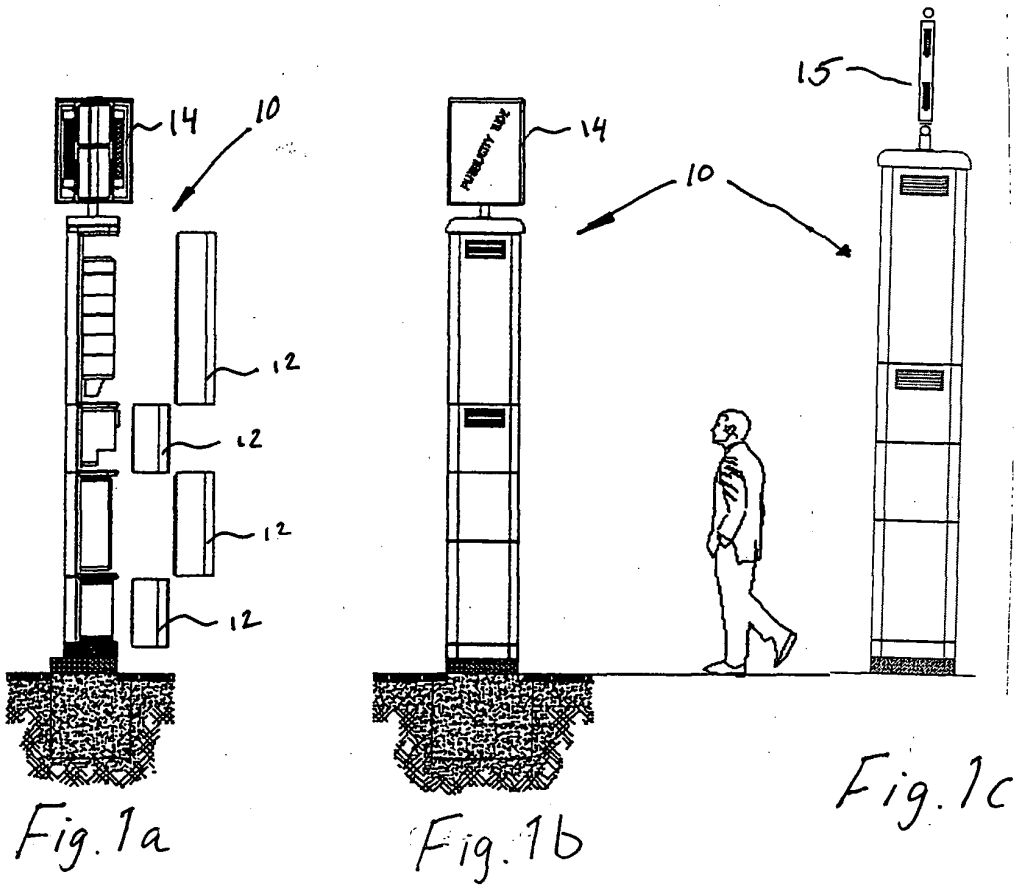

Fig. 2

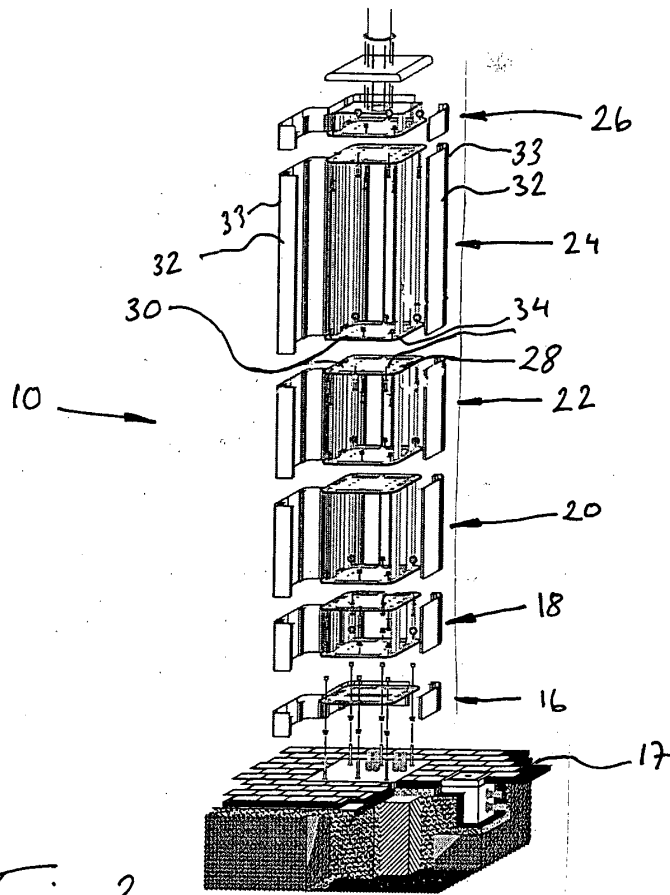

Fig. 3

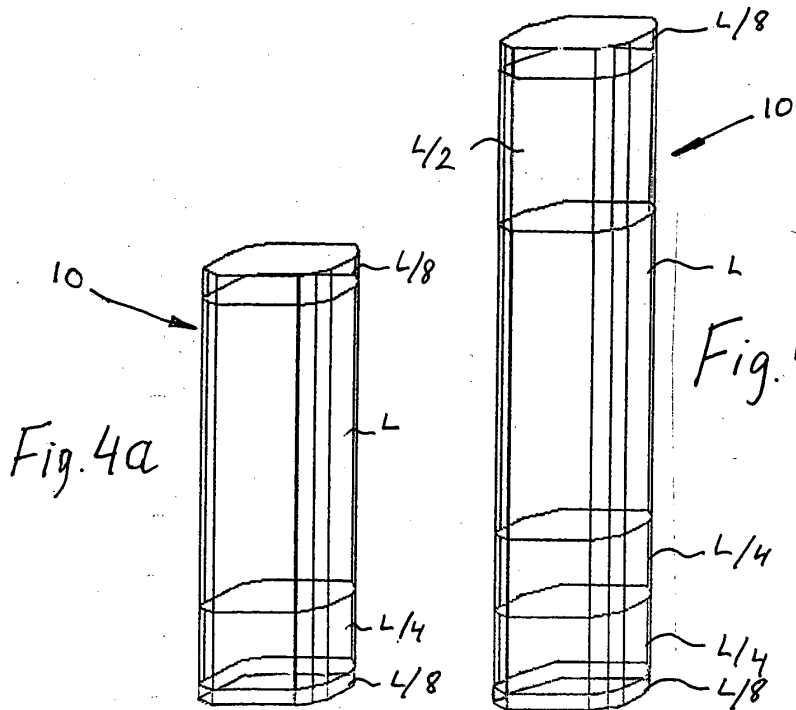

Fig. 4a

Fig. 4b



European Patent Office

EUROPEAN SEARCH REPORT

Application Number
EP 03 02 4316

DOCUMENTS CONSIDERED TO BE RELEVANT			
Category	Citation of document with indication, where appropriate, of relevant passages	Relevant to claim	CLASSIFICATION OF THE APPLICATION (Int.Cl.7)
X	US 6 297 958 B1 (LUTZ JR RONALD D) 2 October 2001 (2001-10-02) * the whole document *	1-3	E04H1/12
X	US 5 810 459 A (MCAULEY RICHARD S ET AL) 22 September 1998 (1998-09-22) * column 7, line 20 - line 32; figures *	1-5	
A	US 2002/136042 A1 (EDEVOLD CRAIG ET AL) 26 September 2002 (2002-09-26) * paragraph [0051]; figures *	1-3	
			TECHNICAL FIELDS SEARCHED (Int.Cl.7)
			H04Q E04H
The present search report has been drawn up for all claims			
Place of search THE HAGUE		Date of completion of the search 5 March 2004	Examiner Fordham, A
<p>CATEGORY OF CITED DOCUMENTS</p> <p>X : particularly relevant if taken alone Y : particularly relevant if combined with another document of the same category A : technological background O : non-written disclosure P : intermediate document</p> <p>T : theory or principle underlying the invention E : earlier patent document, but published on, or after the filing date D : document cited in the application L : document cited for other reasons & : member of the same patent family, corresponding document</p>			

1

EPO FORM 1503 03/02 (P04C01)

**ANNEX TO THE EUROPEAN SEARCH REPORT
ON EUROPEAN PATENT APPLICATION NO.**

EP 03 02 4316

This annex lists the patent family members relating to the patent documents cited in the above-mentioned European search report. The members are as contained in the European Patent Office EDP file on
The European Patent Office is in no way liable for these particulars which are merely given for the purpose of information.

05-03-2004

Patent document cited in search report	Publication date	Patent family member(s)	Publication date
US 6297958	B1	02-10-2001	NONE

US 5810459	A	22-09-1998	NONE

US 2002136042	A1	26-09-2002	US 6310783 B1 30-10-2001
		AU 4959301 A	08-10-2001
		DE 20122043 U1	15-01-2004
		EP 1269205 A2	02-01-2003
		WO 0173914 A2	04-10-2001

EPO FORM P0459

For more details about this annex : see Official Journal of the European Patent Office, No. 12/82