



(12) **UK Patent** (19) **GB** (11) **2 147 029 B**

(54) Title of invention

**Suspension ceiling grid system with narrow-faced grid**

(51) INT CL<sup>4</sup>; **E04B 5/55**

(21) Application No  
**8423594**

(22) Date of filing  
**18 Sep 1984**

(30) Priority data

(31) **535382**

(32) **23 Sep 1983**

(33) **United States of America  
(US)**

(43) Application published  
**1 May 1985**

(45) Patent published  
**11 Feb 1987**

(73) Proprietors  
**Donn Incorporated**

**(Incorporated in USA-Ohio)**

**1000 Crocker Road  
Westlake  
Ohio 44145  
United States of America**

(72) Inventor  
**Richard Shirley** *Shirley*

(74) Agent and/or  
Address for Service  
**Lloyd Wise, Tregear & Co.,  
Norman House,  
105-109 Strand,  
London WC2R 0AE**

(52) Domestic classification  
(Edition I)  
**E1D 151 2031 501 545 902 LEKM**

(56) Documents cited  
• **GB A 2118591 -  
GB 1526989  
GB 1424603  
GB 1030796  
GB 0945971  
GB 0785320**

(58) Field of search  
**E1D**

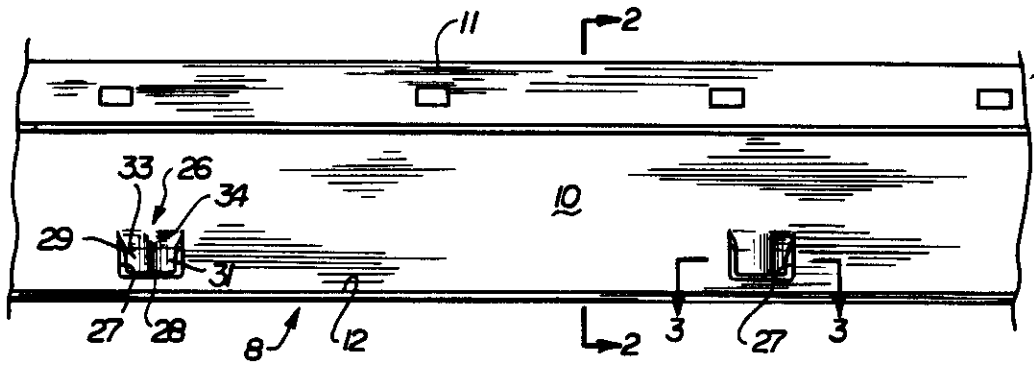

FIG. 1

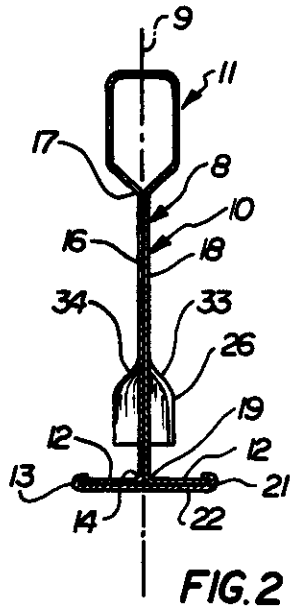

FIG. 2

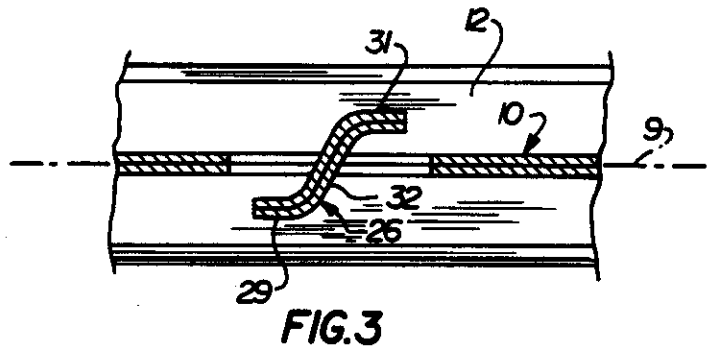

FIG. 3

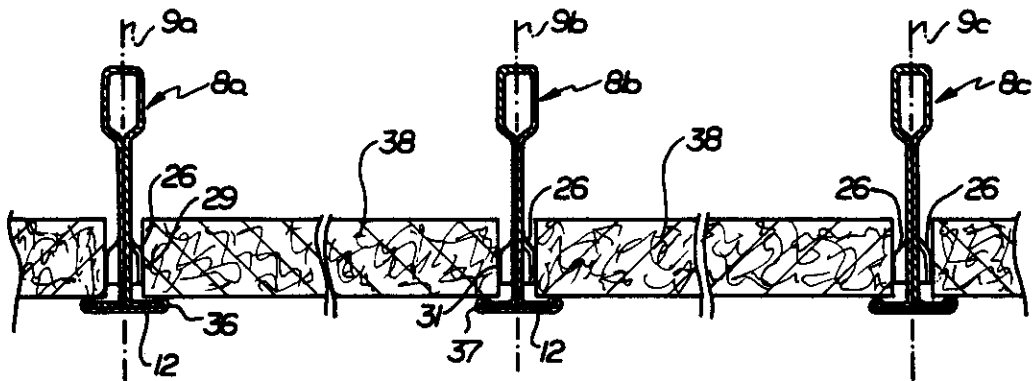
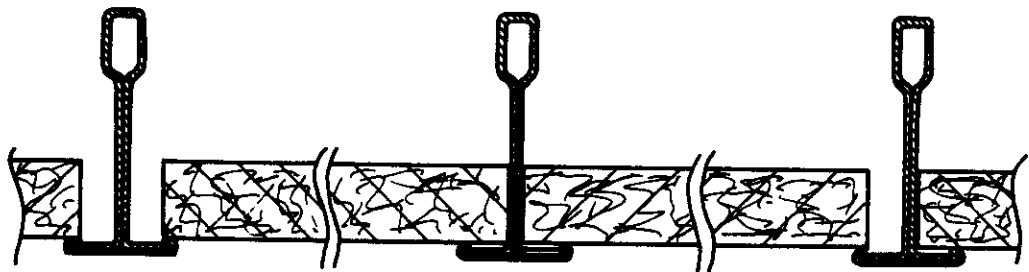

FIG. 4



**FIG 5**  
(PRIOR ART)

SUSPENSION CEILING GRID SYSTEM WITH  
NARROW-FACED GRID

Background of the Invention

This invention relates generally to suspension ceiling grid systems, and more particularly to a novel and improved, narrow-faced grid for suspension ceilings which provides panel centering means to ensure that the panels are properly supported on the narrow panel supporting flanges of the grid.

In this specification, non-metric units of length have been supplemented by equivalent metric values, in accordance with Rule 20(13) of the Patents Rules 1982. However, since the grid system of this invention is described with particular reference to embodiments whose dimensions are calculated in feet and inches it is these non-metric values which are the more meaningful.

Prior Art

Grid systems for suspension ceilings typically provide inverted T-shaped grid members which are formed with a central web, a bulb at the upper extremity of the web, and oppositely extending panel supporting flanges at the lower edges of the web.

The flange width of such grids are usually 15/16 inch to 1 inch (2.38 cm - 2.54 cm) in width. Such grid members or runners are interconnected to define rectangular panel openings bounded by the panel supporting flanges.

The center-to-center distance between runners on opposite sides of each opening determines the module size of the grid opening. For example, one common module size is 2' x 4' (61 x 122 cm). In such grids, the center-to-center spacing of the grid members extending along the long sides of the panel openings is

2 feet (61 cm), and the center-to-center grid spacing of the grid members along the narrow side of the panel openings is 4 feet (122 cm).

The standard panels for installation in such a grid are rectangular, and are undersized in both directions  $1/4$  inch  $\pm$   $1/16$  inch (0.635 cm  $\pm$  0.159 cm). The panels are produced undersized or with clearance so that they can be easily positioned in or removed from the grid panel openings. Such a clearance ensures that the panels can be dropped down past the grid bulbs and the grid hanger wires and so that the panels will not bind on the webs of the grid.

When panels are provided with a clearance of  $1/4$  inch  $\pm$   $1/16$  inch (0.635  $\pm$  0.159 cm), the minimum dimension of a panel for a 2' x 4' (61 x 122 cm) module grid system is 1'.  $11-11/16$  inches by 3'.  $11-11/16$  inches (60.2 cm x 121.1 cm). Since the standard grids have a flange width of at least  $15/16$  inch (2.38 cm), the spacing between the web of a grid member from one side of a panel opening at the closest edge of the panel supporting flange on the opposite side of the opening (assuming a 2' x 4' i.e. 61 x 122 cm, module) is 1'.  $11-17/32$  inches by 3'.  $11-17/32$  inches (59.76 cm x 120.73 cm). (For purposes of this discussion, the webs are assumed to have zero thickness because they generally are formed of thin metal.) Since the panel size exceeds its corresponding dimensions by at least  $5/32$  inch (0.397 cm), a non-centered panel (a panel positioned along one or two edges against the adjacent web) still extends over the opposed flange and is supported thereby by more than  $1/8$  inch (0.3175 cm). Because webs actually have some thickness, the overlap in the case of the non-centered panel is greater than  $5/32$  inch (0.397 cm), and is usually at least about  $3/16$  inch (0.476 cm), even when the panels are at minimum dimensions of their tolerances and are offset from the center the maximum

possible amount.

Fig. 5 of the accompanying drawings illustrates a typical prior art grid system in which the grid members provide a face or flange width of 15/16 inch (2.38 cm) and a standard lay-in panel with 5/16 inch (0.794 cm) clearance is positioned in a maximum off-center position but is still properly supported.

Because of this clearance requirement, conventional grid systems must be provided with a grid face width of at least about 15/16 inch (2.38 cm), even though it is desirable in some instances, from an aesthetic standpoint and from a material standpoint, to provide narrower faced grids.

One prior art type of narrow faced grid is known. Such grid has a shape or cross section substantially as illustrated in U.S. Letters Patent to McCall No. 4,021,986. Such grids have been produced with a face width of about 9/16 inch (1.43 cm), and are used with panels which are rabbeted along their lower edges to fit down along the sides of the lower box sections. Such panels, when installed, provide lower faces which are flush with the lower edges of the box section, as illustrated in Fig. 2 of such patent.

The engagement between the vertical sides of the rabbets and the sidewalls of the box section operates to center the panels within the openings, and thereby assure adequate panel support along all sides thereof, even though the panel supporting flanges at the upper edges of the box section are relatively narrow.

Such grid sections, however, require additional bends, and do not reduce the amount of metal required to produce the grids. Further, the rabbeted panels are more expensive to produce and must be produced to close tolerances.

Another type of narrow-faced grid is disclosed in the co-pending application (assigned to the assignee

of the present invention) of Gale E. Sauer, U.S. Serial No. 214,250, filed December 8, 1980. In such grid system, a grid runner is provided with two diverging webs which space the grid flanges from each other and  
5 are sized to be resiliently compressed when the panels are installed.

#### Summary of the Invention

In accordance with the present invention there is provided a narrow-faced suspension ceiling grid  
10 comprising a plurality of grid tees interconnected to form a grid providing a plurality of panel openings, said grid tees providing a central web and a pair of opposed flanges extending from the lower extremity of said web, the lower surface of said flanges being  
15 exposed and providing said grid tees with a face having a fixed face width equal to the distance between the edge extremities of said opposed flanges, a plurality of panels positioned in said panel openings each providing a lower planar surface extending to lateral edges  
20 thereof, said lower surface of said panels overlying associated flanges of said grid tees and being supported thereby, said panels being undersized with respect to said grid to provide a predetermined maximum clearance with respect to said webs of said grid tees, said face  
25 width being at least substantially as small as twice said predetermined clearance, and centering means operable to center said panels and provide a substantially uniform spacing between said edges of said panels and the adjacent of said webs equal to substantially one-half of  
30 said clearance, said centering means comprising projection means separated from the remaining material of said web by a lance cut having a portion extending in the direction of said flanges and another portion inclined relative to the direction of said flanges, said projection  
35 means providing inclined camming surfaces extending from

said web operating to engage the edges of said panels and cam said panels into a centered position as said panels move into engagement with said flanges.

The present invention further provides a narrow-  
5 faced suspension ceiling grid comprising a panel supporting grid including a plurality of interconnected grid runners cooperating to define panel openings, said runners providing vertically extending webs and lateral flanges extending from and supported thereby, said  
10 openings being bounded by opposed pairs of said flanges, at least one pair of said flanges being spaced a first predetermined distance apart, panels positioned in said openings providing a lower surface overlying and supported by associated pairs of flanges along opposed  
15 edges of said panels, the one of said opposed pairs of edges associated with said one of said pairs of flanges being spaced from each other by a second predetermined distance greater than said first predetermined distance and at least substantially as small as the spacing  
20 between one flange of said one pair of opposed flanges and the web associated with the other flange of said one pair of flanges whereby a panel positioned against said web associated with said other flange of said one pair of flanges is inadequately supported by said one flange  
25 of said one pair of flanges, and centering means operating to center said panel in a location spaced from the edges of said flanges and from said webs so that both of said one pair of flanges adequately support the associated edges of said panel, said centering means  
30 including downwardly extending lanced tabs formed from the material of said webs projecting laterally therefrom at longitudinal locations along the length of said grid runners, said tabs being twisted to provide portions on both sides of said webs whereby each tab is operable to  
35 provide centering of two panels wherein one panel of each two panels is located on each side of said web.

Yet further the present invention provides narrow-faced grid tees for suspension ceiling grid systems comprising a central web, a bulb along one edge of said web, and oppositely extending fixed panel supporting flanges along the opposite edge of said web, said tees  
5 being structured to be assembled in a grid defining panel openings bounded by exposed flanges of a predetermined size to support lay-in panels sized to provide a predetermined clearance with said webs, said flanges  
10 having a width at least substantially as small as said clearance whereby uncentered panels would be inadequately supported by said flanges, said grid tees providing centering means operable to center panels in said openings causing reliable support thereof by said flanges,  
15 said centering means comprising projection means separated from the remaining material of said web by a lance cut having a portion extending in the direction of said flanges and another portion inclined relative to the direction of said flanges, said projection means providing  
20 inclined camming surfaces extending from said web operating to engage the edges of said panels and cam said panels into a centered position as said panels move into engagement with said flanges.

The present invention thus provides a novel and  
25 improved, narrow-faced grid system which can be used with conventional lay-in panels, and does not require the use of rabbeted panels. Such grids provide substantially conventional T-shaped grid members which provide a central web, a bulb along one web extremity, and opposed  
30 panel supporting flanges along the opposite web extremity. Such flanges, however, are narrower than conventional grids.

The flanges are preferably at least about 9/16 inch (1.43 cm) wide when used with standard clearance  
35 panels, and are therefore incapable of reliably providing full support of non-centered panels. However, there are

provided centering means in the form of lanced tabs or projections formed from the material of the webs which operate to center the panels and ensure proper panel support, even though the flanges are relatively narrow.

5           A simple, low-cost suspension ceiling grid system can thus be provided in which the grid members are formed with aesthetically desirable, narrow-face. Because the grid face is narrow compared to conventional wide-faced grids, narrower material may be used to produce the grid  
10 members than is required to produce conventional wide-faced grid. Further, such grid members may be used with standard unrabbeted lay-in panels or tile.

A preferred embodiment of the present invention will now be described in detail with reference to the  
15 accompanying drawings, in which:

Fig. 1 is a side elevation of a grid member in accordance with the preferred embodiment;

Fig. 2 is a cross section, taken along line 2-2 of Fig. 1, illustrating the grid cross section;

20           Fig. 3 is an enlarged longitudinal cross section through the centering tabs taken along line 3-3 of Fig. 1;

Fig. 4 is a fragmentary broken view of a portion of a ceiling incorporating grid members in accordance with the first embodiment of this invention; and

25           Fig. 5 is a fragmentary cross section of a typical prior art wide-faced grid illustrating how even off-center panels are supported.

Fig. 2 illustrates the cross-sectional shape of a grid tee shown in elevation in Fig. 1. Such tee 8 is  
30 symmetrical about a central plane 9 and includes a central web 10 providing a bulb 11 at the upper extremity of the web and opposed, laterally extending flanges 12 at the lower extremity of the web. In this embodiment, the tee is formed of a strip of material which extends  
35 inwardly from one edge at 13 to a first right angle bend at 14. From the right angle bend at 14, the strip

extends up providing one layer 16 of the web at 10. At the upper extremity of the web layer 16, the strip is bent outwardly at 17 and above the web is formed in a closed box shape to provide the bulb 11. The strip then  
5 extends down the second web layer 18 to a right angle bend at 19 and out along the flange 12 to an edge 21.

A cap strip 22 is folded over the two outer edges 13 and 21 to form the face portion of the flanges.

The tee section thus far described is  
10 conventional in that it provides a bulb at one extremity of the web, a double-faced web and oppositely extending flanges at the lower extremity of the web. However, in this embodiment, the flanges 12 are much narrower than provided in a conventional grid tee and have a total face  
15 width of about 9/16 inch (1.43 cm). As discussed above, conventional grid tees usually have a face width or flange width of 15/16 inch (2.38 cm) or 1 inch (2.54 cm).

Formed at intervals along the length of the web are a plurality of centering tabs 26. These tabs in  
20 this illustrated embodiment are formed by making a U-shaped cut 27 through the two layers 16 and 18 of the web 10 (see Fig. 1). Such cut produces a downwardly extending tab 28 which is twisted, as best illustrated in Fig. 3, to provide a first portion 29 substantially  
25 parallel to the plane 9 of the grid tee 8 and laterally spaced therefrom on one side of the web and a second portion 31 substantially parallel to the plane 9 but laterally spaced therefrom on the opposite side thereof. Intermediate the two portions 29 and 31, the tab provides  
30 an inclined or laterally extending portion 32 which joins the two portions 29 and 31. The two portions 29 and 31 are essentially planar, and in the illustrated embodiment are displaced on opposite sides of the central plane of the web 10 so that the outer surfaces of the portions 29  
35 and 31 are spaced apart almost a quarter of an inch (0.635 cm), with the result that such surfaces are

located at slightly less than 1/8 inch (0.3175 cm) on each side of the central plane 9 of the web 10.

Above the planar portions 29 and 31, the tab provides two camming portions or transition portions 33 and 34, which are inclined inwardly from the planar portions 29 and 31, respectively, into the web itself (see Fig. 2). The planar portions 29 and 31 are spaced upwardly from the flanges 12 a short distance, and are sufficiently close to the flanges so that when a conventional tile or panel is placed in the grid opening, the planar portions engage the edges of the panel and space the edges thereof from the plane 9 of the web by a distance about 1/8 inch (0.3175 cm). In practice, the centering tabs 26 are formed in the web at intervals along the length of each of the grid tee members, e.g. at intervals of about 3 inches (7.62 cm).

Referring now to Fig. 4, when grid tees are assembled in a grid to define panel openings, a pair of grid tees 8 are located on opposite sides of each opening and the spacing between the central planes 9 is determined by the module size. One typical module size is 2' x 4' (61 cm x 122 cm). However, other module sizes are commonly provided. The panel openings are defined by opposed pairs of grid tees 8, with the first pair defining the 2-foot (61 cm) module dimension and perpendicularly extending second pairs defining the 4-foot (122 cm) module dimension. As illustrated in Fig. 4, one of the module dimensions is defined by a pair of parallel and laterally spaced grid tees 8a and 8b and an adjacent opening defined by grid tees 8b and 8c. The central planes 9a are spaced apart, for example, by 2 feet or 4 feet, depending upon which pair of grid members are being considered. For purposes of discussion, it is assumed that the grid members 8a and 8b define the 4-foot (122 cm) dimension of the module. Therefore, the central planes 9a of these two grid members are spaced apart 4 feet (122 cm).

Because the grid faces have a lateral width of 9/16 inch (1.43 cm), the adjacent edges 36 and 37, respectively, of the grid members 8a and 8b are spaced apart by a distance of 4 feet minus 9/16 inch (122 cm minus 1.43 cm), or 3 feet, 11-7/16 inches (about 120.5 cm). However, the spacing between the planar portion 29 of the centering tab on the grid 8a and the planar portion 31 on the centering tab of the grid member 8b is slightly more than 3 feet, 11-3/4 inches (121.3 cm).

As discussed above, a standard panel is provided with a clearance of 1/4 inch  $\pm$  1/16 inch (0.635 cm  $\pm$  0.159 cm), so a minimum corresponding dimension of a conventional 2' x 4' (61 x 122 cm) panel is 3 feet, 11-11/16 inches by 1 foot, 11-11/16 inches (121.13 cm x 60.2 cm), and a maximum panel size within the tolerance range would be 3 feet, 11-13/16 inches by 1 foot, 11-13/16 inch (121.44 cm x 60.48 cm). Even a minimum size panel, therefore, provides a lateral width along the 4-foot (122 cm) nominal dimension, which is greater than the lateral spacing between the adjacent edges of the adjacent flanges of 3 feet, 11-7/16 inch (about 120.5 cm) by about 1/4 inch (0.635 cm). Therefore, when a panel 38 is dropped into the opening and is centered by the centering tabs, it is supported or overlays the associated flange by about 1/8 inch (0.3175 cm) along each side edge of the panel. If the panel having a maximum dimension of 3 feet, 11-13/16 inches (121.44 cm) is inserted in the opening, it provides slightly more overlap or support by the flanges.

The centering tabs are sufficiently resilient to be deflected a small amount when a maximum diameter panel is installed to prevent binding or, in some instances in which the panels themselves are formed of relatively soft material, the centering tabs may provide a slight indentation of the concealed edges of the

panels. In any event, a grid formed of grid members incorporating the first embodiment are provided with relatively narrow faces in the order of 9/16 inch (1.43 cm) wide, and proper support of standard panels is achieved because of the centering mechanism provided at intervals along the length of the flanges. In this embodiment, the face width of the grid tees is about 9/16 inch (1.43 cm), which is less than twice the maximum panel clearance, and yet reliable panel support is provided.

Material savings are achieved when compared to conventional prior art grids because the flanges are substantially narrower, reducing the width requirement for the strip of material forming the main part of the tee and also for the facing cap. Since the centering tabs are formed from the material of the web, no additional material is required to provide the centering function, which ensures proper support of the panels.

Because each of the planar portions of the centering tabs 29 and 31 is joined to the adjacent portions of the web immediately thereabove by an inclined camming surface 33 or 34, the panels do not hang up and are automatically centered as they drop into position in the grid openings.

It should be understood that even though the present invention has been illustrated in connection with a typical double-web grid member, it is equally applicable to grids with a single layer of web. Further, it is applicable to grid tees formed in other ways.

## CLAIMS:

1. A narrow-faced suspension ceiling grid comprising a plurality of grid tees interconnected to form a grid providing a plurality of panel openings, said grid tees providing a central web and a pair of  
5 opposed flanges extending from the lower extremity of said web, the lower surface of said flanges being exposed and providing said grid tees with a face having a fixed face width equal to the distance between the edge extremities of said opposed flanges, a plurality of  
10 panels positioned in said panel openings each providing a lower planar surface extending to lateral edges thereof, said lower surface of said panels overlying associated flanges of said grid tees and being supported thereby, said panels being undersized with respect to  
15 said grid to provide a predetermined maximum clearance with respect to said webs of said grid tees, said face width being at least substantially as small as twice said predetermined clearance, and centering means operable to center said panels and provide a  
20 substantially uniform spacing between said edges of said panels and the adjacent of said webs equal to substantially one-half of said clearance, said centering means comprising projection means separated from the remaining material of said web by a lance cut having a  
25 portion extending in the direction of said flanges and another portion inclined relative to the direction of said flanges, said projection means providing inclined camming surfaces extending from said web operating to engage the edges of said panels and cam said panels into  
30 a centered position as said panels move into engagement with said flanges.

2. A narrow-faced suspension ceiling grid as set forth in Claim 1, wherein said projection means

includes a planar portion substantially parallel to said web, said planar portion operating to engage the edges  
5 of the panels resting on said flanges with a substantial area of contact to maintain said panel centered in said openings.

3. A narrow-faced suspension ceiling grid as set forth in Claim 2, wherein said projection means provide a camming surface and a planar portion on each side of said web.

4. A narrow-faced suspension ceiling grid as set forth in Claim 3, wherein said projection means provide similar and opposite camming surfaces and planar portions on each side of said web.

5. A narrow-faced suspension ceiling grid as set forth in Claim 3 or Claim 4, wherein said projection means includes a plurality of separate projections spaced along said grid tees, each projection providing a  
5 camming surface and a planar portion on each side of said central plane.

6. A narrow-faced suspension ceiling grid as set forth in any one of Claims 3-5, wherein the or each said lance cut is generally U-shaped with the base of said U extending in the direction of said flanges and  
5 providing longitudinally spaced legs of said U extending substantially perpendicular to the direction of said flanges, said lance cut separating the metal of said projection from the metal of said web along both sides thereof, and each said projection being twisted and bent  
10 to provide said camming surfaces and planar portion on both sides of said central plane without substantial stretching of the metal of said projection.

7. A narrow-faced suspension ceiling grid as set forth in any one of Claims 3-6, wherein said face width is about 9/16 inch (1.43 cm) and said planar portions are spaced from said central plane by about  
5 1/8 inch (0.3175 cm).

8. A narrow-faced suspension ceiling grid as set forth in any preceding claim, wherein said projection means are laterally resilient.

9. A narrow-faced suspension ceiling grid as set forth in any preceding claim, wherein said projection means includes a plurality of lateral projections spaced along the length of said webs which  
5 are resiliently deformable in a direction substantially perpendicular to said webs.

10. A narrow-faced suspension ceiling grid comprising a panel supporting grid including a plurality of interconnected grid runners cooperating to define panel openings, said runners providing vertically  
5 extending webs and lateral flanges extending from and supported thereby, said openings being bounded by opposed pairs of said flanges, at least one pair of said flanges being spaced a first predetermined distance apart, panels positioned in said openings providing a  
10 lower surface overlying and supported by associated pairs of flanges along opposed edges of said panels, the one of said opposed pairs of edges associated with said one of said pairs of flanges being spaced from each other by a second predetermined distance greater than  
15 said first predetermined distance and at least substantially as small as the spacing between one flange of said one pair of opposed flanges and the web associated with the other flange of said one pair of flanges whereby a panel positioned against said web

20 associated with said other flange of said one pair of  
flanges is inadequately supported by said one flange of  
said one pair of flanges, and centering means operating  
to center said panel in a location spaced from the edges  
of said flanges and from said webs so that both of said  
25 one pair of flanges adequately support the associated  
edges of said panel, said centering means including  
downwardly extending lanced tabs formed from the  
material of said webs projecting laterally therefrom at  
longitudinal locations along the length of said grid  
30 runners, said tabs being twisted to provide portions on  
both sides of said webs whereby each tab is operable to  
provide centering of two panels wherein one panel of  
each two panels is located on each side of said web.

11. A narrow-faced suspension ceiling grid as  
set forth in Claim 10, wherein each of said lanced tabs  
includes a camming surface inclined away from the  
adjacent portion of said web in the direction of the  
5 flanges and a planar portion having a substantial area  
extent thereof parallel to said web and laterally spaced  
therefrom.

12. A narrow-faced suspension ceiling grid as  
set forth in Claim 10 or Claim 11, wherein each of said  
lanced tabs is provided by a U-shaped lance cut having a  
base of said U extending in the direction of said  
5 flanges and a pair of longitudinally spaced legs of said  
U extending substantially perpendicular to the direction  
of said flanges.

13. Narrow-faced grid tees for suspension  
ceiling grid systems comprising a central web, a bulb  
along one edge of said web, and oppositely extending  
fixed panel supporting flanges along the opposite edge  
5 of said web, said tees being structured to be assembled

in a grid defining panel openings bounded by exposed flanges of a predetermined size to support lay-in panels sized to provide a predetermined clearance with said webs, said flanges having a width at least substantially  
10 as small as said clearance whereby uncentered panels would be inadequately supported by said flanges, said grid tees providing centering means operable to center panels in said openings causing reliable support thereof by said flanges, said centering means comprising  
15 projection means separated from the remaining material of said web by a lance cut having a portion extending in the direction of said flanges and another portion inclined relative to the direction of said flanges, said projection means providing inclined camming surfaces  
20 extending from said web operating to engage the edges of said panels and cam said panels into a centered position as said panels move into engagement with said flanges.

14. A narrow-faced suspension ceiling grid tee as set forth in Claim 13, wherein said projection means includes a plurality of separate projections spaced along said grid tees, each projection providing a  
5 camming surface and a planar portion on each side of said central plane.

15. A narrow-faced suspension ceiling grid tee as set forth in Claim 14, wherein said lance cut is generally U-shaped with the base of said U extending in the direction of said flanges and providing  
5 longitudinally spaced legs of said U extending substantially perpendicular to the direction of said flanges, said lance cut separating the metal of said projection from the metal of said web along both sides thereof, and said projection being twisted and bent to  
10 provide said camming surfaces and planar portions on both sides of said central plane without substantial

stretching of the metal of said projection.

16. A narrow-faced suspension ceiling grid  
tee as set forth in Claim 14 or Claim 15, wherein said  
projections are bent to shape as they are lance cut  
without applying any substantial tensile stress to said  
5 web.

17. A narrow-faced suspension ceiling grid  
tee as set forth in any one of Claims 14-16, wherein  
said predetermined clearance is substantially 1/4 inch  
(0.635 cm) and each of said planar portions is laterally  
5 spaced from said web a distance substantially equal to  
1/8 inch (0.3175 cm).

18. A narrow-faced suspension ceiling grid  
tee as set forth in Claim 17, wherein said predetermined  
size of said flange width is substantially 9/16 inch  
(1.43 cm).

19. A narrow-faced suspension ceiling grid  
tee substantially as hereinbefore described with  
reference to Figs. 1-4 of the accompanying drawings.

20. A narrow-faced suspension ceiling grid  
substantially as hereinbefore described with reference  
to Figs. 1-4 of the accompanying drawings.

---

Publication No.  
2147029 A dated 1 May 1985

Patent Granted:

WITH EFFECT FROM  
SECTION 2(1) 11 FEB 1987

Application No.  
8423594 filed on 18 September 1984

Priority claimed:  
23 September 1983 in United States of America doc: 535382

Title:  
Suspension ceiling grid system with narrow-faced grid

Applicant:  
Donn Incorporated (USA-Ohio), 1000 Crocker Road, Westlake, Ohio 44145,  
United States of America.

Inventor:  
Richard Shirey, 2799 Lear Nagle, Avon Lake, Ohio 44011, United States of America.

Classified to:  
E1D

Examination requested 22 OCT 1985

Address for Service:  
Lloyd Wise Tregear & Co, Norman House, 105-109 Strand, London WC2R OAE.