



US 20170182429A1

(19) **United States**

(12) **Patent Application Publication**
CHOI

(10) **Pub. No.: US 2017/0182429 A1**

(43) **Pub. Date: Jun. 29, 2017**

(54) **SURFACE STRUCTURE FOR THE CONNECTION BETWEEN BLOCKS EQUIPPED WITH MAGNET OF BLOCK TOYS**

(52) **U.S. CL.**
CPC *A63H 33/046* (2013.01)

(57) **ABSTRACT**

(71) Applicant: **So Yeong CHOI**, Seongnam-si (KR)

(72) Inventor: **So Yeong CHOI**, Seongnam-si (KR)

(21) Appl. No.: **15/371,007**

(22) Filed: **Dec. 6, 2016**

(30) **Foreign Application Priority Data**

Dec. 28, 2015 (KR) 2020150008560

Publication Classification

(51) **Int. Cl.**
A63H 33/04 (2006.01)

Disclosed herein is a block toy that has a magnet embedded inside and a surface structure for connecting a block thereof, wherein overhang-like structures and hollow-like structures are formed on the block surface of the block toy that has a magnet embedded inside so that the overhang-like structures on each block surface interlock organically with the hollow-like structures on each block surface in order to secure stable assembly between the blocks of a block toy when the blocks are stacked up or interlocking at right angles or laterally to each other, thereby, especially, preventing the block thus interlocked from slipping out of the assembly with the external force that is exerted in a direction other than the direction the block interlocks in when it is stacked up or interlocking at right angles or laterally with each other.

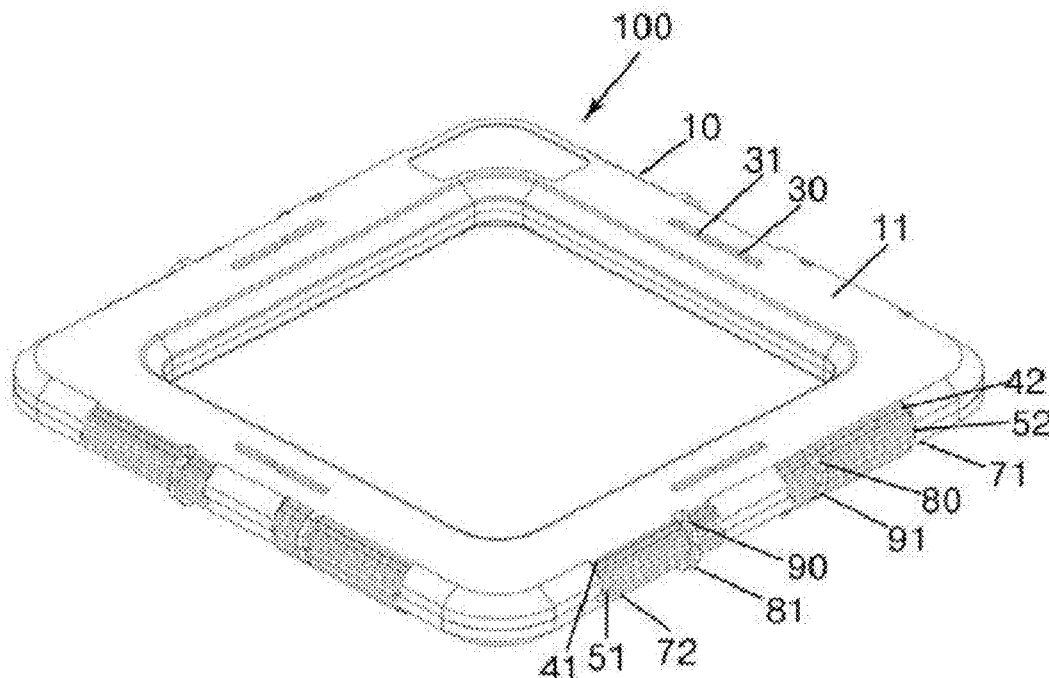

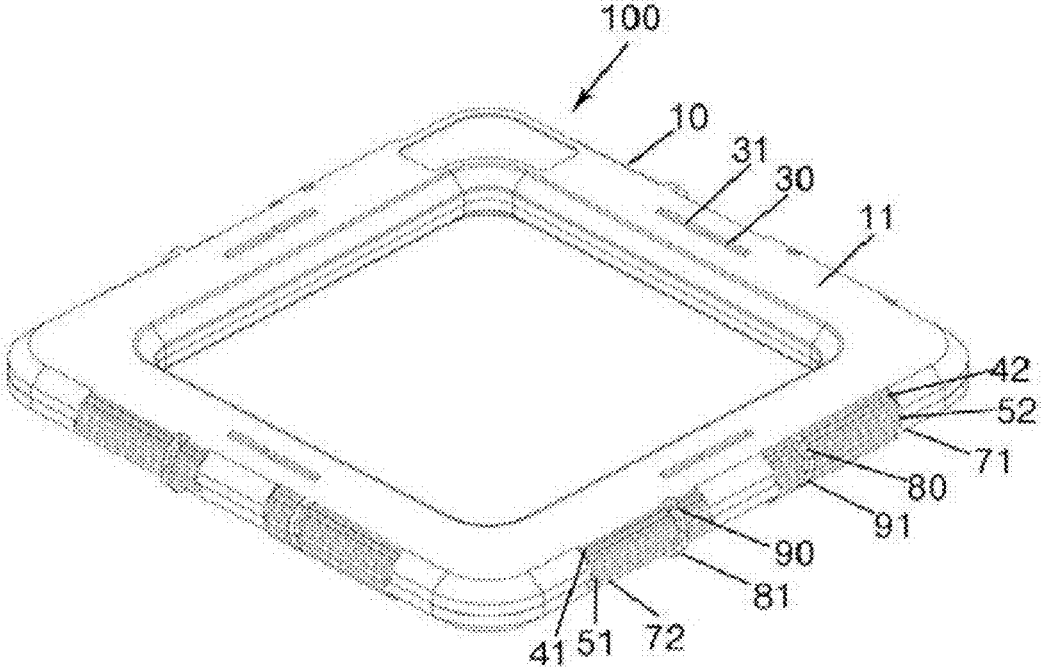

FIG 1

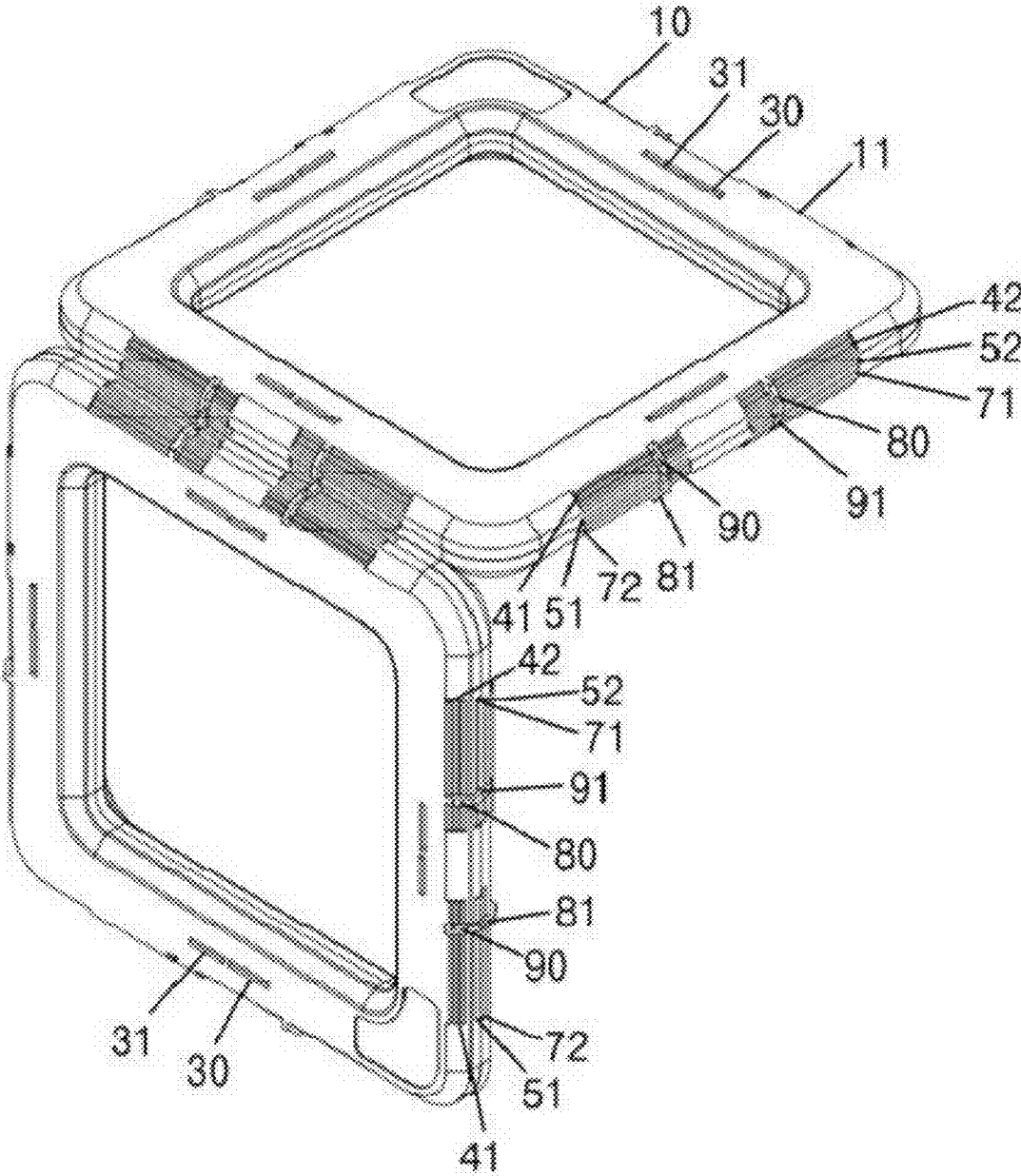

FIG 3



FIG 5A

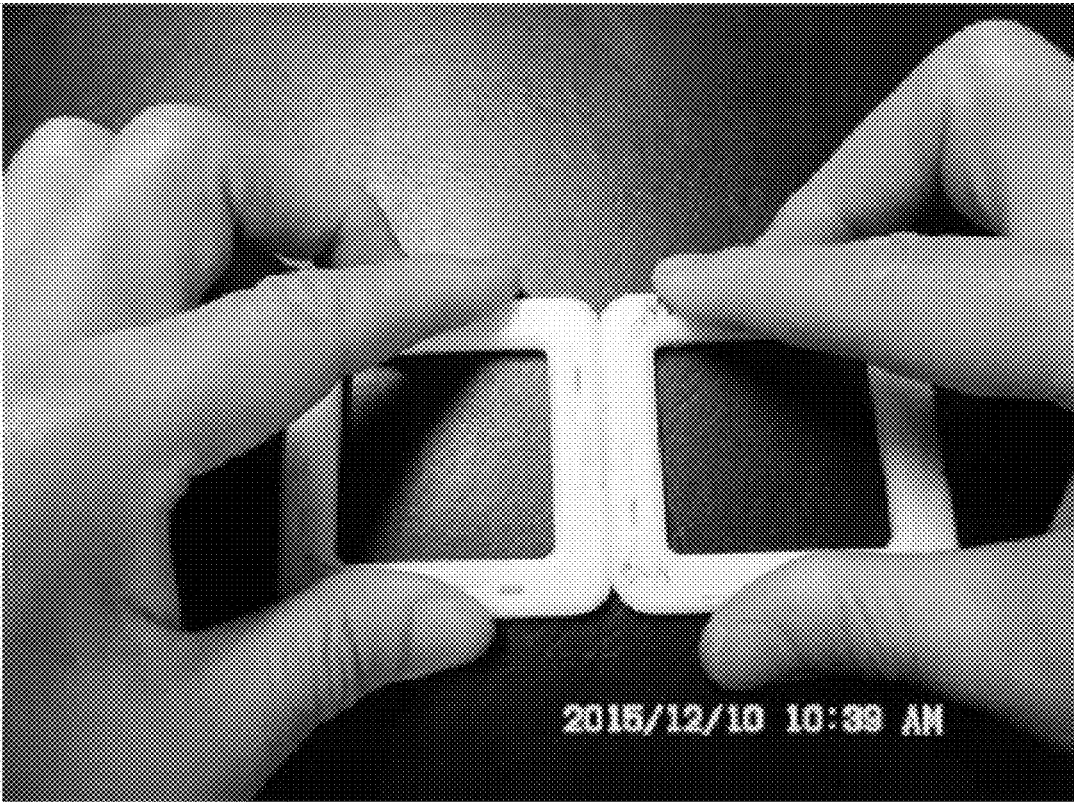

FIG 5B

**SURFACE STRUCTURE FOR THE
CONNECTION BETWEEN BLOCKS
EQUIPPED WITH MAGNET OF BLOCK
TOYS**

BACKGROUND OF THE DISCLOSURE

[0001] 1. Field of the Disclosure

[0002] The present disclosure relates to a surface structure for connecting a block of a block toy that has a magnet embedded inside, and more particularly, to a block toy that has a magnet embedded inside and a surface structure for connecting a block thereof, wherein overhang-like structures and hollow-like structures are formed on the block surface of the block toy that has a magnet embedded inside so that the overhang-like structures on each block surface interlock organically with the hollow-like structures on each block surface in order to secure stable assembly between the blocks of a block toy when the blocks are stacked up or interlocking at right angles or laterally with each other, thereby, especially, preventing the block thus interlocked from slipping out of the assembly with the external force that is exerted in a direction other than the direction the block interlocks in when it is stacked up or interlocking at right angles or laterally with each other.

[0003] 2. Description of the Related Art

[0004] A block toy includes a plurality of and a set of small blocks that are typically made of plastic so that the blocks are to be assembled to construct a solid shape. Self-assembly toys, as a kind of block toys, have been marketed for which it is required to interlock the protuberances and slots configured in each block to complete the toy. As for such a self-assembly toy, it is, however, also required to forcefully plug each protuberance into each slot corresponding to the protuberance in each block and, even after the assembly is completed, it is not very easy to disassemble the blocks to construct another solid shape.

[0005] Those block toys have also been marketed that include blocks with magnets embedded inside so that the blocks are easily assembled by means of magnetism when brought proximately to each other. As for such a block toy with magnets, although it is convenient to assemble the blocks with each other by means of magnetism and also convenient to disassemble after the assembly is completed, the form may collapse with a rather slight impact because, in most cases, the edges of the blocks are rounded and, correspondingly, the binding between the blocks is not firm. To resolve the problem, the applicant of the present disclosure provided Korean Utility Model Registration No. 20-0475198, SURFACE STRUCTURE FOR THE CONNECTION BETWEEN BLOCKS EQUIPPED WITH MAGNET OF BLOCK TOYS. The utility model provides significantly firm binding between the blocks although the edges of the blocks are rounded, thereby considerably increases the normal maximum compressive load. However, it shows a drawback in that the block thus assembled slips out of the assembly with the external force that is exerted in a direction other than the direction the block interlocks in when it is stacked up or interlocking at right angles or laterally with each other.

[0006] The applicant has continued to study a surface structure that may bind the blocks together more stably and hereby provides a surface structure that may bind the blocks together stably preventing the block from slipping out of the

block assembly with the external force that is exerted in any direction even including the direction the block interlocks in.

RELATED ART DOCUMENTS

Patent Literature

[0007] (Patent Literature 1) Korean Utility Model Registration No. 20-0475198, SURFACE STRUCTURE FOR THE CONNECTION BETWEEN BLOCKS EQUIPPED WITH MAGNET OF BLOCK TOYS, as registered on Nov. 5, 2014.

SUMMARY OF THE DISCLOSURE

[0008] The present disclosure is directed to a block toy that has a magnet embedded inside and a surface structure for connecting a block thereof, wherein overhang-like structures and hollow-like structures are formed on the block surface of the block toy that has a magnet embedded inside so that the overhang-like structures on each block surface interlock organically with the hollow-like structures on each block surface in order to secure stable assembly between the blocks of a block toy when the blocks are stacked up or interlocking at right angles or laterally with each other, thereby, especially, preventing the block thus interlocked from slipping out of the assembly with the external force that is exerted in a direction other than the direction the block interlocks in when it is stacked up or interlocking at right angles or laterally with each other.

[0009] A surface structure for the connection between blocks equipped with magnet of block toys according to the present disclosure includes a block of a block toy as a single assembly, into which a top frame and a bottom frame are integrated, that assumes the shape of a quadrate panel with an opening at the center and has, inside and at the center of each of the four sides of the top frame and the bottom frame, a magnet holder with an internal space for magnet rotation into which a single cylindrical magnet or two cylindrical magnets in tandem are placed in the longitudinal direction of the edge of the top frame and the bottom frame, respectively, wherein a lateral protuberance and a fitting slot are alternately arranged with a certain distance in between on a top plane of the top frame and a bottom plane of the bottom frame in the longitudinal direction of the edge of the top plane and the bottom plane so that, when another block is laid down on the top plane of the top frame of the block, the lateral protuberance of the top plane of the top frame of the underlying block is plugged into the fitting slot of the bottom plane of the bottom frame of the overlying block while the fitting slot of the top frame of the underlying block is plugged with the lateral protuberance of the bottom plane of the bottom frame of the overlying block; a top inclined plane is extended from the edge of the top frame at 45° downward while a top vertical plane drops from the top inclined plane; a bottom inclined plane is extended from the edge of the bottom frame at 45° upward while a bottom vertical plane rises from the bottom inclined plane; three—top, middle and bottom—steps of a tongue are formed on the left of a spot slightly to the left of the center of the top inclined plane with a certain distance from the spot while three—top, middle and bottom—steps of a groove that is slightly longer than the tongue are formed on the right side to a level slightly lower than that of the tongue; three—top, middle and bottom—

steps of a groove are formed on the left of a spot slightly to the right of the center of the bottom inclined plane with a certain distance from the spot while three—top, middle and bottom—steps of a tongue that is slightly shorter than the groove are formed on the right side to a level slightly higher than that of the groove; a tongue is formed on the left of a spot slightly to the left of the center of the top vertical plane while a groove that is slightly longer than the tongue is formed on the right side to a level slightly lower than that of the tongue, and a groove is formed on the left of a spot slightly to the right of the center of the bottom vertical plane while a tongue that is slightly shorter than the groove is formed on the right side to a level slightly higher than that of the tongue; a top bump is formed in the right middle of the right groove of the top inclined plane and the right groove of the top vertical plane at right angles to the grooves to a level higher than that of the tongues while a top depression is formed in the right middle of the left tongue of the top inclined plane and the left tongue of the top vertical plane at right angles to the tongues; and a bottom bump is formed in the right middle of the left groove of the bottom inclined plane and the left groove of the bottom vertical plane at right angles to the grooves to a level higher than that of the tongues while a bottom depression is formed in the right middle of the right tongue of the bottom inclined plane and the right tongue of the bottom vertical plane at right angles to the tongues.

[0010] Meanwhile, the block into which the top frame and the bottom frame are integrated has a width and height of 60 to 70 mm and a thickness of 6 to 9 mm.

[0011] The lateral protuberance and the fitting slot has an identical depth of 0.8 to 1.0 mm. The grooves on the top and bottom inclined planes have a depth of, and the tongues formed thereon have a height of 0.25 to 0.35 mm.

[0012] The grooves on the top and bottom vertical planes have a depth of, and the tongues formed thereon have a height of 0.4 to 0.6 mm.

[0013] In addition, the bumps and the depressions have a height and depth, respectively, of 0.8 to 1.0 mm.

[0014] A block toy that has a magnet embedded inside and a surface structure for connecting a block thereof according to the present disclosure has overhang-like structures and hollow-like structures on the surface of each of the blocks so that the structures organically interlock with each other when the blocks are stacked up or interlocking at right angles or laterally with each other, thereby being capable of stably binding the blocks together.

[0015] In particular, the present disclosure may prevent the block thus interlocked from slipping out of the assembly with the external force that is exerted in a direction other than the direction the block interlocks in when it is stacked up or interlocking at right angles or laterally with each other.

BRIEF DESCRIPTION OF THE SEVERAL VIEWS OF THE DRAWINGS

[0016] FIG. 1 is a perspective view of a magnet block on which a surface structure is configured according to the present disclosure.

[0017] FIG. 2 is a perspective view of magnet blocks stacked up according to the present disclosure.

[0018] FIG. 3 is a perspective view of magnet blocks that interlock with each other at right angles according to the present disclosure.

[0019] FIG. 4 is a perspective view of magnet blocks that interlock with each other laterally according to the present disclosure.

[0020] FIG. 5A shows blocks, on which a surface structure is configured according to the related art, that interlock with each other laterally and are pushed in the opposite direction to each other.

[0021] FIG. 5B shows blocks, on which a surface structure is configured according to the present disclosure, that interlock with each other laterally and are pushed in the opposite direction to each other.

DETAILED DESCRIPTION OF THE EMBODIMENTS

[0022] Embodiments of the present disclosure are described in detail below with reference to the drawings.

[0023] FIG. 1 is a perspective view of a magnet block on which a surface structure is configured according to the present disclosure and FIG. 2 is a perspective view of magnet blocks stacked up according to the present disclosure.

[0024] A block 100 of a block toy according to the present disclosure that has a magnet inside is a single assembly, into which a top frame 10 and a bottom frame 20 are integrated, that assumes the shape of a quadrate panel with an opening at the center and has, inside and at the center of each of the four sides of the top frame 10 and the bottom frame 20, a magnet holder (not illustrated) with an internal space for magnet rotation into which a single cylindrical magnet or two cylindrical magnets in tandem (not illustrated) are placed in the longitudinal direction of the edge of the top frame 10 and the bottom frame, respectively.

[0025] When two cylindrical magnets are placed in the magnet holder, the blocks attract each other more strongly than the blocks having a single cylindrical magnet in the magnet holder do because the blocks with two cylindrical magnets have more polarities. It may be required the block 100 into which the top frame 10 and the bottom frame 20 are integrated have a width and height of 60 to 70 mm and a thickness of 6 to 9 mm and assume the shape of a quadrate panel with an opening in the center because a width and height less than 60 and thickness less than 6 mm are not adequate while a width and height more than 70 and thickness more than 9 mm are excessive for a block for a block toy. According to an aspect of the present disclosure, the block 100 into which the top frame 10 and the bottom frame 20 are integrated has a width and height of 65 mm and thickness of 7 mm and assumes the shape of a quadrate panel that has an opening in the center, with the width of each of the four sides being 11 mm. A lateral protuberance 30 and a fitting slot 31 are alternately arranged with a certain distance in between on a top plane 11 of the top frame 10 and a bottom plane 21 of the bottom frame 20 in the longitudinal direction of the edge of the top plane 11 and the bottom plane 21 so that, when another block is laid down on the top plane 11 of the top frame 10 of the block, the lateral protuberance 30 of the top plane 11 of the top frame 10 of the underlying block is plugged into the fitting slot 31 of the bottom plane 21 of the bottom frame 20 of the overlying block while the fitting slot 31 of the top frame 10 of the underlying block is plugged with the lateral protuberance 30 of the bottom plane 21 of the bottom frame 20 of the overlying block.

[0026] It may be required the lateral protuberance 30 and the fitting slot 31 has an identical depth that ranges between

0.8 to 1.0 mm because the interlocking force may decrease between the lateral protuberance 30 and the fitting slot 31 when the depth is less than 0.8 mm while a depth more than 1.0 mm makes the lateral protuberance 30 protrude excessively high, thereby bringing about inconvenience in using the block. According to an aspect of the present disclosure the lateral protuberance 30 and the fitting slot 31 has a depth of 0.9 mm.

[0027] As described above, the surface structure of the block is used for stacking up the blocks according to the present disclosure preventing the block from slipping out of the assembly with the external force that is exerted in a direction other than the direction the block is stacked up.

[0028] FIG. 3 is a perspective view of magnet blocks that interlock with each other at right angles according to the present disclosure and FIG. 4 is a perspective view of magnet blocks that interlock with each other laterally according to the present disclosure. A top inclined plane 40 is extended from the edge of the top frame 10 at 45° downward while a top vertical plane 50 drops from the top inclined plane 40, and a bottom inclined plane 60 is extended from the edge of the bottom frame 20 at 45° upward while a bottom vertical plane 70 rises from the bottom inclined plane 60.

[0029] Three—top, middle and bottom—steps of a tongue 41 are formed on the left of a spot slightly to the left of the center of the top inclined plane 40 with a certain distance from the spot while three—top, middle and bottom—steps of a groove 42 that is slightly longer than the tongue 41 are formed on the right side to a level slightly lower than that of the tongue 41, and three—top, middle and bottom—steps of a groove 62 are formed on the left of a spot slightly to the right of the center of the bottom inclined plane 60 with a certain distance from the spot while three—top, middle and bottom—steps of a tongue 61 that is slightly shorter than the groove 62 are formed on the right side to a level slightly higher than that of the groove 62.

[0030] A tongue 51 is formed on the left of a spot slightly to the left of the center of the top vertical plane 50 while a groove 52 that is slightly longer than the tongue 51 is formed on the right side to a level slightly lower than that of the tongue 51, and a groove 72 is formed on the left of a spot slightly to the right of the center of the bottom vertical plane 70 while a tongue 71 that is slightly shorter than the groove 72 is formed on the right side to a level slightly higher than that of the tongue 72.

[0031] A top bump 80 is formed in the right middle of the right groove 42 of the top inclined plane 40 and the right groove 52 of the top vertical plane 50 at right angles to the grooves 42, 52 to a level higher than that of the tongues 41, 51, 61, 71 while a top depression 90 is formed in the right middle of the left tongue 41 of the top inclined plane 40 and the left tongue 51 of the top vertical plane 50 at right angles to the tongues 41, 51, and a bottom bump 81 is formed in the right middle of the left groove 62 of the bottom inclined plane 60 and the left groove 72 of the bottom vertical plane 70 at right angles to the grooves 62, 72 to a level higher than that of the tongues 41, 51, 61, 71 while a bottom depression 91 is formed in the right middle of the right tongue 61 of the bottom inclined plane 60 and the right tongue 71 of the bottom vertical plane 70 at right angles to the tongues 61, 71.

[0032] As for the top inclined plane 40 and the bottom inclined plane 60, the grooves 42, 62 are formed slightly lower and longer than the tongues 41, 61 while the tongues

41, 61 are formed slightly higher and shorter than the grooves 42, 62, thereby easily plugging the tongues 41, 61 into the grooves 42, 62.

[0033] When the grooves 42, 62 are formed slightly lower and longer than the tongues 41, 61, it may be required each of the grooves 42, 62 have a depth of and each of the tongues 41, 61 have a height of 0.25 to 0.35 mm because a depth of each of the grooves 42, 62 and a height of each of the tongues 41, 61 less than 0.25 mm weakens the interlocking force between, for example, the tongue 41 of the top inclined plane 40 and the groove 62 of the bottom inclined plane 60 and because, when considering there are provided the bumps 80, 81 and the depressions 90, 91, it is not necessary for each of the grooves 42, 62 to have a depth and each of the tongues 41, 61 to have a height more than 0.35 mm in order to increase the interlocking force between the tongue 41 of the top inclined plane 40 and the groove 62 of the bottom inclined plane. According to an aspect of the present disclosure, the tongues 41, 61 have a height of 0.35 mm while the grooves 42, 62 have a depth of 0.3 mm.

[0034] As for the top vertical plane 50 and the bottom vertical plane 70, the grooves 52, 72 are formed slightly lower and longer than the tongues 51, 71 while the tongues 51, 71 are formed slightly higher and shorter than the grooves 52, 72, thereby easily plugging the tongues 51, 71 into the grooves 52, 72.

[0035] When the grooves 52, 72 are formed slightly lower and longer than the tongues 51, 71, it may be required the grooves 52, 72 have a depth of and the tongues 51, 71 have a height of 0.4 to 0.6 mm because a depth of the grooves 52, 72 and a height of the tongues 51, 71 less than 0.4 mm weakens the interlocking force between the grooves 52, 72 and the tongues 51, 71 and because, when considering there are provided the bumps 80, 81 and the depressions 90, 91, it is not necessary for the grooves 52, 72 to have a depth and the tongues 51, 71 to have a height more than 0.6 mm in order to increase the interlocking force between the tongue 51, 71 and the groove 52, 72. According to an aspect of the present disclosure, the tongues 51, 71 have a height of 0.55 mm while the grooves 52, 72 have a depth of 0.5 mm

[0036] As for the bumps 80, 81 that are formed in the middle of the grooves 42, 52, 62, 72 and the depressions 90, 91 that are formed in the middle of the tongues 41, 51, 61, 71, the depressions 90, 91 into which the bumps are plugged are formed in the tongues 41, 51, 61, 71 that are formed at a level higher than that of the grooves 42, 52, 62, 72 because the depressions do not protrude above the surface and the bumps 80, 81 are formed in the grooves 42, 52, 62, 72 that are formed at a level lower than that of the tongues 41, 51, 61, 71 so that the bumps do not protrude above the surface to a large extent even when the bumps protrude over the tongues 41, 51, 61, 71 because the bumps 80, 81 should protrude above the surface and any bump that protrudes to a large extent may make the block toy inconvenient to play with.

[0037] It may be required the height of the bumps 80, 81 and depth of the depressions 90, 91 be 0.8 to 1.0 mm because the interlocking force between, for example, the top bump 80 and the bottom depression becomes too weak when the bumps 80, 81 have a height less than 0.8 mm and the bumps 80, 81 protrude excessively to make the block toy inconvenient to play with when the bumps 80, 81 have a height more

than 1.0 mm. According to an aspect of the present disclosure, the bumps **80**, **81** and the depressions **90**, **91** have a depth of 0.9 mm.

[0038] As described, the surface structure of a block is used when the blocks interlock at right angles or laterally with each other, where, when two blocks according to the present disclosure interlock with each other at right angles, for example, the tongue **41** and the groove **42** on the top inclined plane **40** of the upright block interlocks with the groove **62** and the tongue **61**, respectively, on the bottom inclined plane **60** of the recumbent block, the top bump **80** of the upright block is plugged into the bottom depression **91** of the recumbent block and the bottom bump **81** of the recumbent block is plugged into the top depression **90** of the upright block, thereby preventing the block from slipping out of the assembly with external force that is exerted in a direction other than the direction the block interlocks in when it interlocks at right angles.

[0039] In addition, when two blocks according to the present disclosure interlock with each other laterally, the tongue **71** and the groove **72** on the bottom vertical plane **70** of a first block interlocks with the groove **52** and the tongue **51** in the upper portion of the top vertical plane **50** of a second block, the top bump **80** in the right portion of the top vertical plane **50** of the first block is plugged into the top depression **90** in the left portion of the top vertical plane **50** of the second block and the bottom bump **81** in the left portion of the bottom vertical plane **70** of the first block is plugged into the bottom depression **91** in the right portion of the bottom vertical plane **70** of the second block, thereby preventing the block from slipping out of the assembly with external force that is exerted in a direction other than the direction the block interlocks in when it interlocks laterally.

[0040] The surface structure described above is configured in each of the four sides and edges of the block **100** that assumes the shape of a quadrate panel according to the present disclosure.

[0041] Although the block according to the present disclosure has the bumps **80**, **81** that slightly protrude less than 1.0 mm, it doesn't make the block toy inconvenient to play with, securing firm binding when the blocks thus assembled are stacked up or interlock with each other at right angles or laterally, especially preventing the block from slipping out of the assembly with the external force that is exerted in a direction other than the direction the block interlocks in.

[0042] FIG. 5A shows blocks, on which a surface structure is configured according to the conventional art, that interlock with each other laterally and are pushed in the opposite direction to each other and FIG. 5B shows blocks, on which a surface structure is configured according to the present disclosure, that interlock with each other laterally and are pushed in the opposite direction to each other.

[0043] Blocks having a surface structure according to the related art easily slip out of the assembly when they interlock laterally with each other and are manually and slightly pulled in the opposite direction to each other, as illustrated in FIG. 5A, whereas the blocks having the surface structure according to the present disclosure do not slip at all when they interlock laterally with each other and are manually and forcefully pulled in the opposite direction to each other, as illustrated in FIG. 5B.

[0044] Although a quadrate panel is exemplarily provided in the present disclosure, the shape of the block is not limited

to a quadrate but may be various including rectangle, triangle, hexagon, octagon, etc.

[0045] The present disclosure has been described thus far based on the embodiments exemplarily provided. However, the present disclosure must not be limited to the embodiments but may be changed or modified in a plurality ways within the scope and the technical thoughts of the claims. Therefore, all the changes and modifications, and equivalents, especially change and modification in the length, height, distance, etc. of the configuration of the overhang-like and hollow-like structures according to the change in the dimension of the panel-like block must be interpreted to be included in the scope of the present disclosure.

REFERENCE CHARACTERS

[0046]	100: Block according to the present disclosure
[0047]	10: Top frame
[0048]	11: Top plane
[0049]	20: Bottom frame
[0050]	21: Bottom plane
[0051]	30: Lateral protuberance
[0052]	31: Fitting slot
[0053]	40: Top inclined plane
[0054]	41: Tongue
[0055]	42: Groove
[0056]	50: Top vertical plane
[0057]	51: Tongue
[0058]	52: Groove
[0059]	60: Bottom inclined plane
[0060]	61: Tongue
[0061]	62: Groove
[0062]	70: Bottom vertical plane
[0063]	71: Tongue
[0064]	72: Groove
[0065]	80: Top bump
[0066]	81: Bottom bump
[0067]	90: Top depression
[0068]	91: Bottom depression

What is claimed is:

1. A surface structure for the connection between blocks equipped with a magnet of block toys comprising a block of a block toy as a single assembly, into which a top frame and a bottom frame are integrated, that assumes the shape of a quadrate panel with an opening at the center and has, inside and at the center of each of the four sides of the top frame and the bottom frame, a magnet holder with an internal space for magnet rotation into which a single cylindrical magnet or two cylindrical magnets in tandem are placed in the longitudinal direction of the edge of the top frame and the bottom frame, respectively,

wherein a lateral protuberance and a fitting slot are alternately arranged with a certain distance in between on a top plane of the top frame and a bottom plane of the bottom frame in the longitudinal direction of the edge of the top plane and the bottom plane so that, when another block is laid down on the top plane of the top frame of the block, the lateral protuberance of the top plane of the top frame of the underlying block is plugged into the fitting slot of the bottom plane of the bottom frame of the overlying block while the fitting slot of the top frame of the underlying block is plugged with the lateral protuberance of the bottom plane of the bottom frame of the overlying block;

- a top inclined plane is extended from the edge of the top frame at 45° downward while a top vertical plane drops from the top inclined plane;
- a bottom inclined plane is extended from the edge of the bottom frame at 45° upward while a bottom vertical plane rises from the bottom inclined plane;
- three—top, middle and bottom—steps of a tongue are formed on the left of a spot slightly to the left of the center of the top inclined plane with a certain distance from the spot while three—top, middle and bottom—steps of a groove that is slightly longer than the tongue are formed on the right side to a level slightly lower than that of the tongue;
- three—top, middle and bottom—steps of a groove are formed on the left of a spot slightly to the right of the center of the bottom inclined plane with a certain distance from the spot while three—top, middle and bottom—steps of a tongue that is slightly shorter than the groove are formed on the right side to a level slightly higher than that of the groove;
- a tongue is formed on the left of a spot slightly to the left of the center of the top vertical plane while a groove that is slightly longer than the tongue is formed on the right side to a level slightly lower than that of the tongue, and a groove is formed on the left of a spot slightly to the right of the center of the bottom vertical plane while a tongue that is slightly shorter than the groove is formed on the right side to a level slightly higher than that of the tongue; and
- a top bump is formed in the right middle of the right groove of the top inclined plane and the right groove of the top vertical plane at right angles to the grooves to a level higher than that of the tongues while a top depression is formed in the right middle of the left

tongue of the top inclined plane and the left tongue of the top vertical plane at right angles to the tongues and a bottom bump is formed in the right middle of the left groove of the bottom inclined plane and the left groove of the bottom vertical plane at right angles to the grooves to a level higher than that of the tongues while a bottom depression is formed in the right middle of the right tongue of the bottom inclined plane and the right tongue of the bottom vertical plane at right angles to the tongues.

2. The surface structure for the connection between blocks equipped with a magnet of block toys of claim 1, wherein the block into which the top frame and the bottom frame are integrated has a width and height of 60 to 70 mm and a thickness of 6 to 9 mm.

3. The surface structure for the connection between blocks equipped with a magnet of block toys of claim 1, wherein the lateral protuberance and the fitting slot has an identical depth of 0.8 to 1.0 mm.

4. The surface structure for the connection between blocks equipped with a magnet of block toys of claim 1, wherein the grooves on the top and bottom inclined planes have a depth of, and the tongues formed thereon have a height of 0.25 to 0.35 mm.

5. The surface structure for the connection between blocks equipped with a magnet of block toys of claim 1, wherein the grooves on the top and bottom vertical planes have a depth of, and the tongues formed thereon have a height of 0.4 to 0.6 mm.

6. The surface structure for the connection between blocks equipped with a magnet of block toys of claim 1, wherein the bumps and the depressions have a height and depth, respectively, of 0.8 to 1.0 mm.

* * * * *