

E. M. BENTLEY.

ELECTRIC RAILWAY AND CONTACT DEVICE THEREFOR.

No. 446,376.

Patented Feb. 10, 1891.

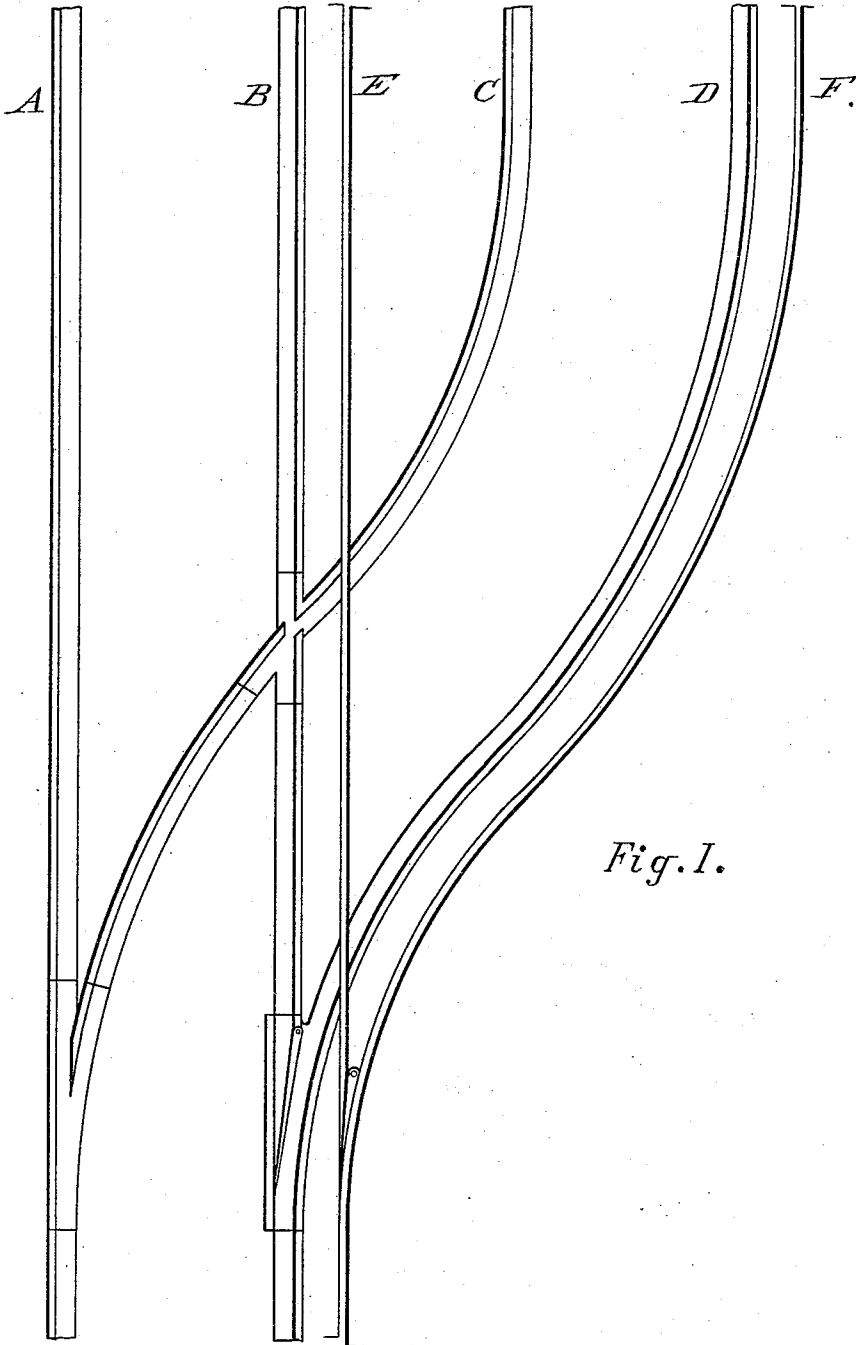

Fig. 1.

WITNESSES

Joseph E. Aue.
Julien M. Elliot

INVENTOR

Edward M. Bentley
by Bentley & Knight
attys

E. M. BENTLEY.

ELECTRIC RAILWAY AND CONTACT DEVICE THEREFOR.

No. 446,376.

Patented Feb. 10, 1891.

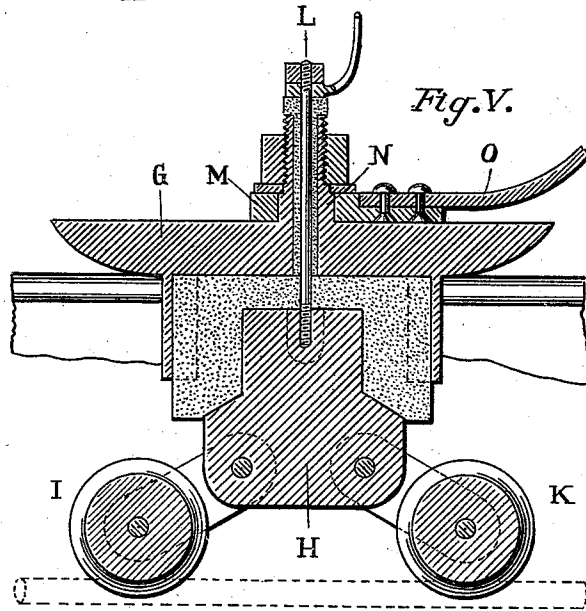
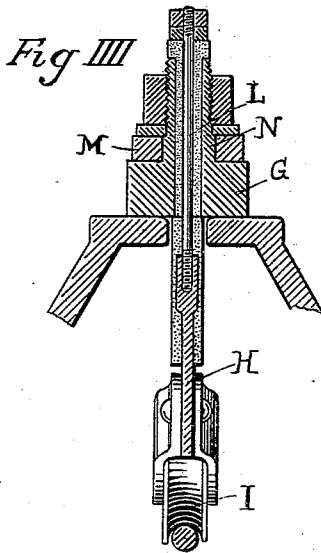
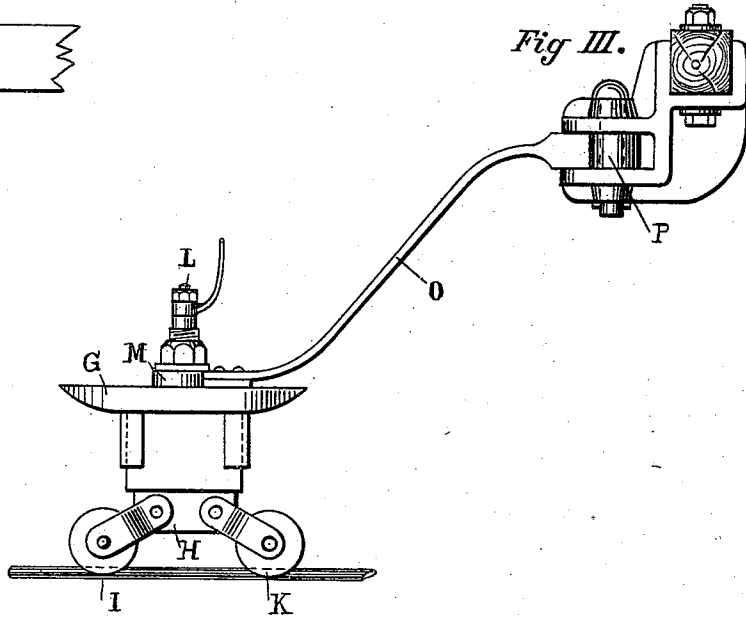
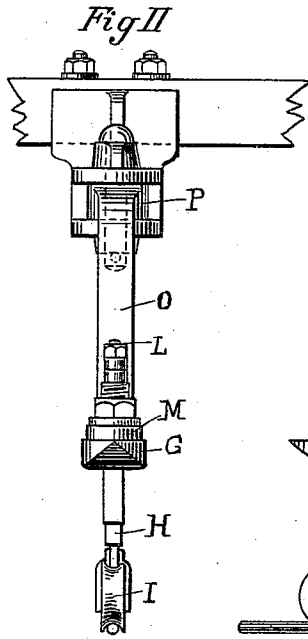

WITNESSES

Joseph E. Auer.
Julien M. Elliot

INVENTOR

Edward M. Bentley
by Bentley & Wright
Attys

UNITED STATES PATENT OFFICE.

EDWARD M. BENTLEY, OF NEW YORK, N. Y.

ELECTRIC RAILWAY AND CONTACT DEVICE THEREFOR.

SPECIFICATION forming part of Letters Patent No. 446,376, dated February 10, 1891.

Application filed September 20, 1888. Serial No. 285,935. (No model.)

To all whom it may concern:

Be it known that I, EDWARD M. BENTLEY, a citizen of the United States, residing at New York, in the county of New York, State of New York, have invented certain new and useful Improvements in Electric Railways and Contact Devices Therefor, of which the following is a specification.

My invention relates to electric railways wherein the supply-conductor is inclosed in a slotted conduit. It has been found desirable for many reasons that in a road of this character the conduit for the conductor should be placed outside of the track. In this case, however, at switch-points where the change is made from a single to a double track it is necessary in the forms heretofore proposed that the contact device pass entirely across the car, so that while being on one side of the car in going in one direction it would be on the opposite side in returning, the two conduits being between the two tracks. This difficulty I intend to avoid by having the conduit in each case on the same side of the track, so that the complicated movement of the contact device may be avoided in passing from single to double track. I have also devised a form of contact device or plow of service in this connection.

My invention is illustrated in the accompanying drawings, wherein—

Figure 1 is a plan of a switch from single to double track. Fig. 2 is an end elevation of my contact device. Fig. 3 is a side elevation thereof. Fig. 4 is a vertical transverse section through the center, and Fig. 5 is a longitudinal vertical section through the center.

A, B, C, and D are respectively the four rails of a double-track railway. E and F are the two conduits therefor, placed outside of the track. Instead, however, of these two conduits being in between the two tracks they are both outside and have the same relative positions to their respective tracks. It will be readily understood that a vehicle coming along one track with its contact device or plow moving in the conduit may run over the switch, and then being reversed will pass back upon the other track without any change in the point of attachment of its plow. The two conduits preferably unite at a point ad-

acent to the track-switch, whereby the two sets of points are near one another and may be operated conveniently.

In my contact device, which may be attached to the side of the vehicle in an inconspicuous manner, G represents the main frame, extending into the conduit so as to take the wear against the slot-iron, and having a flange at its upper edge adapted to ride upon the outside of the conduit.

H is an insulated conducting-core within the frame, having two contact-wheels I and K on transverse axes pivoted at its lower end. Into its upper end an insulated rod L, is screw-threaded and extends up through the frame, and has a flexible conductor leading therefrom to the motor on the car.

M is a ring or collar passing around the shoulder N, projecting above frame G. To this collar M is attached a spring O, which is attached to the car by a joint P. This spring extends out laterally from the car and by reason of its jointed connection therewith and its elasticity it forms a flexible connection, towing the contact device. The spring O has also a downward pressure, which tends to keep the frame G constantly upon the conduit, while the two rollers I and K, bearing on the upper surface of the supply-wire, will be free to pass over any inequalities independently of the frame.

What I claim as new, and desire to secure by Letters Patent, is—

1. The combination, in an electric railway, of two converging tracks uniting in a single track at a switch, with conduits containing supply-conductors for the respective tracks joining into one at a point near the switch, and both placed without and on the same side of their respective tracks, with their slots a uniform distance from the corresponding track-rails, so as to permit a vehicle to travel on either track without shifting of the contact device, as described.

2. The combination, in an electric railway, of a conduit outside the railway-track and a contact device adapted to ride upon the conduit and having a lateral flexible connection with the vehicle.

3. A contact device adapted to ride upon a conduit and having a contact-piece bearing on the upper side of the inclosed conductor, the

contact device being held down upon the conduit independently of the contact-piece.

4. The combination, in an electric railway, of a conduit containing a supply-conductor, and a contact device adapted to ride along the conduit, having a lateral flexible connection with the vehicle holding the contact device down in operative position and provided with contact-pieces bearing on the upper surface of the supply-conductor.

5. The combination, in an electric railway, of a conduit, an inclosed supply-conductor, and a contact device adapted to ride on the conduit and bearing downwardly upon the supply-conductor, with a spring holding the contact device down upon the conduit.

6. The combination, in an electric railway, of a vehicle and a contact device adapted to ride on the outside of the conduit and held down thereon by its mechanical connection with the vehicle, and provided with contact-pieces adapted to ride on the upper part of the supply-conductor.

7. The combination, in an electric railway, of a contact device adapted to ride along the conduit and in engagement with a supply-conductor housed therein, a vehicle to which it is attached, and a spring connection between the vehicle and contact device pressing the latter down upon the conduit.

8. The combination, in an electric railway, of a vehicle, a contact device adapted to ride along the conduit, with a connecting-rod pivoted both to the vehicle and to the contact device and allowing free lateral movement, but tending to hold the contact device down in its operative position.

9. The combination, in an electric railway, of a conduit, an inclosed supply-conductor, and a contact device bearing downwardly upon the conductor and having a shank extending up through the slot, with a spring connected to the vehicle and the shank, and pressing the contact device downward.

10. The combination, in an electric railway, of a conduit, an inclosed supply-conductor, and a contact device for engagement with the conductor, free to move up and down through the slot, with a spring-arm joining the contact device to the vehicle and tending to hold the contact device in its operative position relative to the conductor.

11. The combination, in an electric railway, of a conduit, an inclosed conductor, and a contact device, with a spring-arm pressing upon the contact device and extending lengthwise of the vehicle, and a jointed attachment for the arm, permitting lateral movement of the contact device.

12. The combination, in an electric railway, of a conduit inclosing the supply-conductor, with a plow-shank extending into the conduit, and a plurality of contact-pieces independently pivoted to the shank upon transverse axes and all engaging a single supply-conductor, substantially as set forth.

13. The combination, in an electric railway, of the conduit, the conductor, and the contact-plover consisting of the insulated conducting-core and a contact-piece pivoted thereto on a transverse axis.

14. The combination, in an electric railway, of the conduit, supply-conductor, and contact-plover consisting of the insulated conducting-core and a contact-piece extending rearwardly therefrom and trailing along the conductor.

15. The combination, in an electric railway, of the conduit, the supply-conductor, and the contact-plover consisting of the insulated conducting-core and a plurality of independent contact-pieces connected directly thereto for engagement with the supply-conductor.

16. The combination, in an electric railway, of the conduit and the supply-conductor, supported substantially in line with the slot, with the plow consisting of the insulated conducting-core and a contact-piece pivoted to the core and in engagement with the conductor.

17. The combination of the conduit and the insulated conducting-core wholly inside the conduit and in circuit with the supply-conductor, with a conductor leading from said core outside of the conduit.

18. In a plow for electric railways, the insulated conducting-core having a plurality of contact devices at its lower end and a single conducting-connection extending from its upper end.

19. The combination of the main frame G, sliding along on the outside of the conduit, with an insulating-panel and conductor inclosed in said panel traveling in circuit with the supply-conductor.

20. The combination of a contact device traveling along the outside of a conduit containing the supply-conductor of an electric railway, and comprising a metallic frame having guards or projections taking the wear against the slot, an insulating-panel in the said frame, and an insulated conductor protected by the panel and traveling in circuit with the supply-conductor.

EDWARD M. BENTLEY.

Witnesses:

ROBT. W. BLACKWELL,
DAVID P. THOMSON.