

Nov. 17, 1953

R. E. TAGGART

2,659,341

GLUING ASSEMBLY FOR PACKAGING MACHINES

Filed Aug. 18, 1951

3 Sheets-Sheet 1

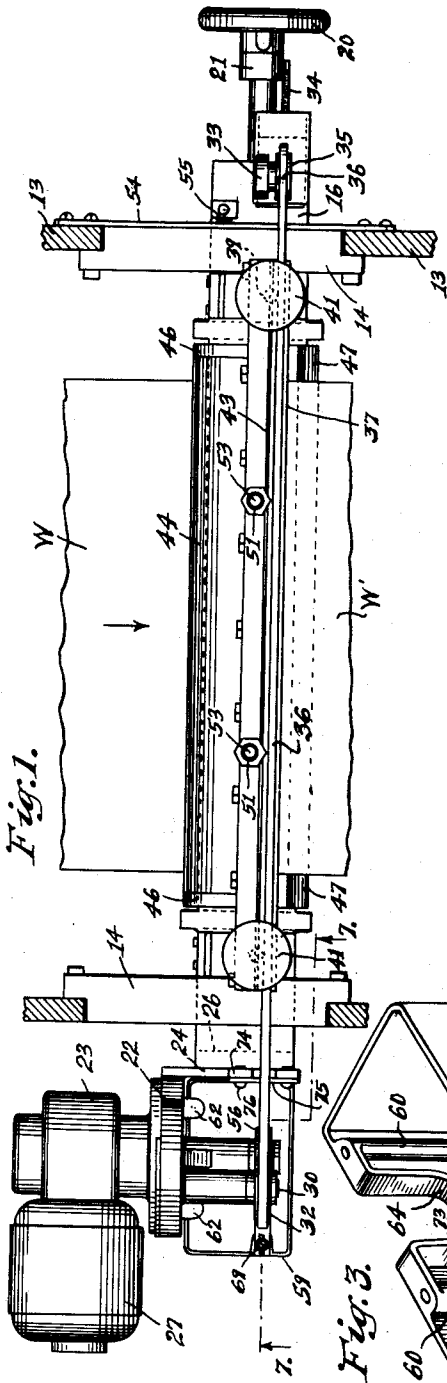

Fig. 1.

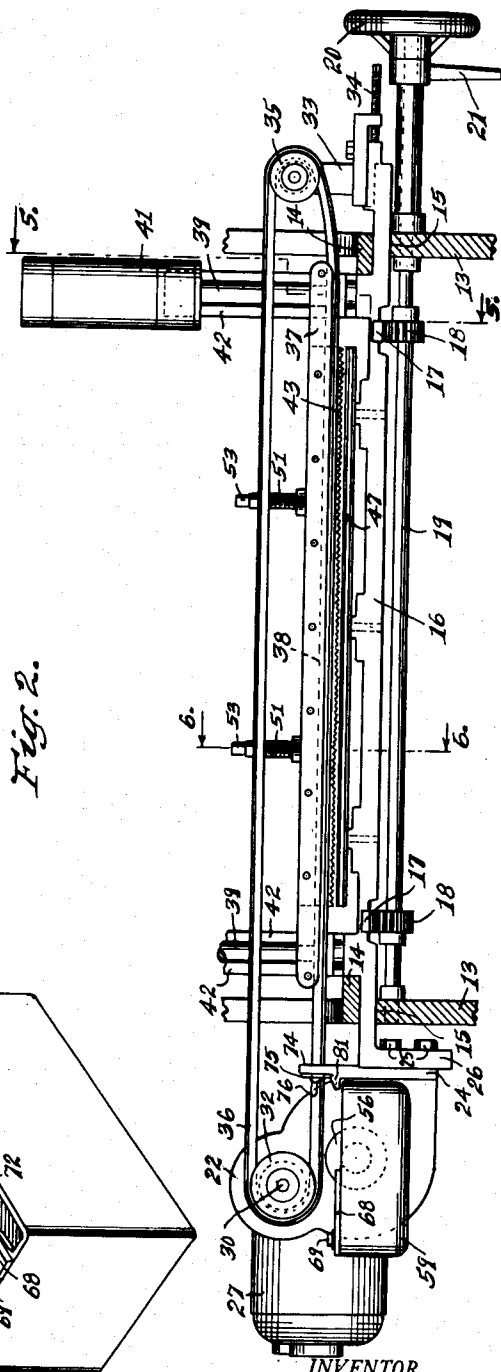

Fig. 2.

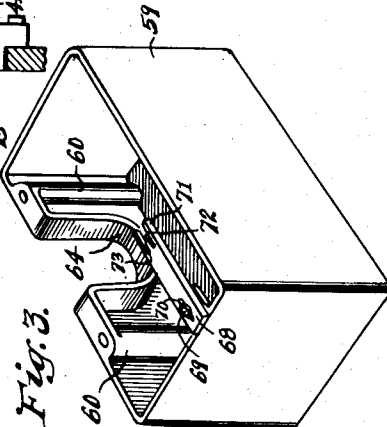

Fig. 3.

INVENTOR.

Robert E. Taggart.

By Bain, Treman & Molinare

Attys.

Nov. 17, 1953

R. E. TAGGART

2,659,341

GLUING ASSEMBLY FOR PACKAGING MACHINES

Filed Aug. 18, 1951

3 Sheets-Sheet 2

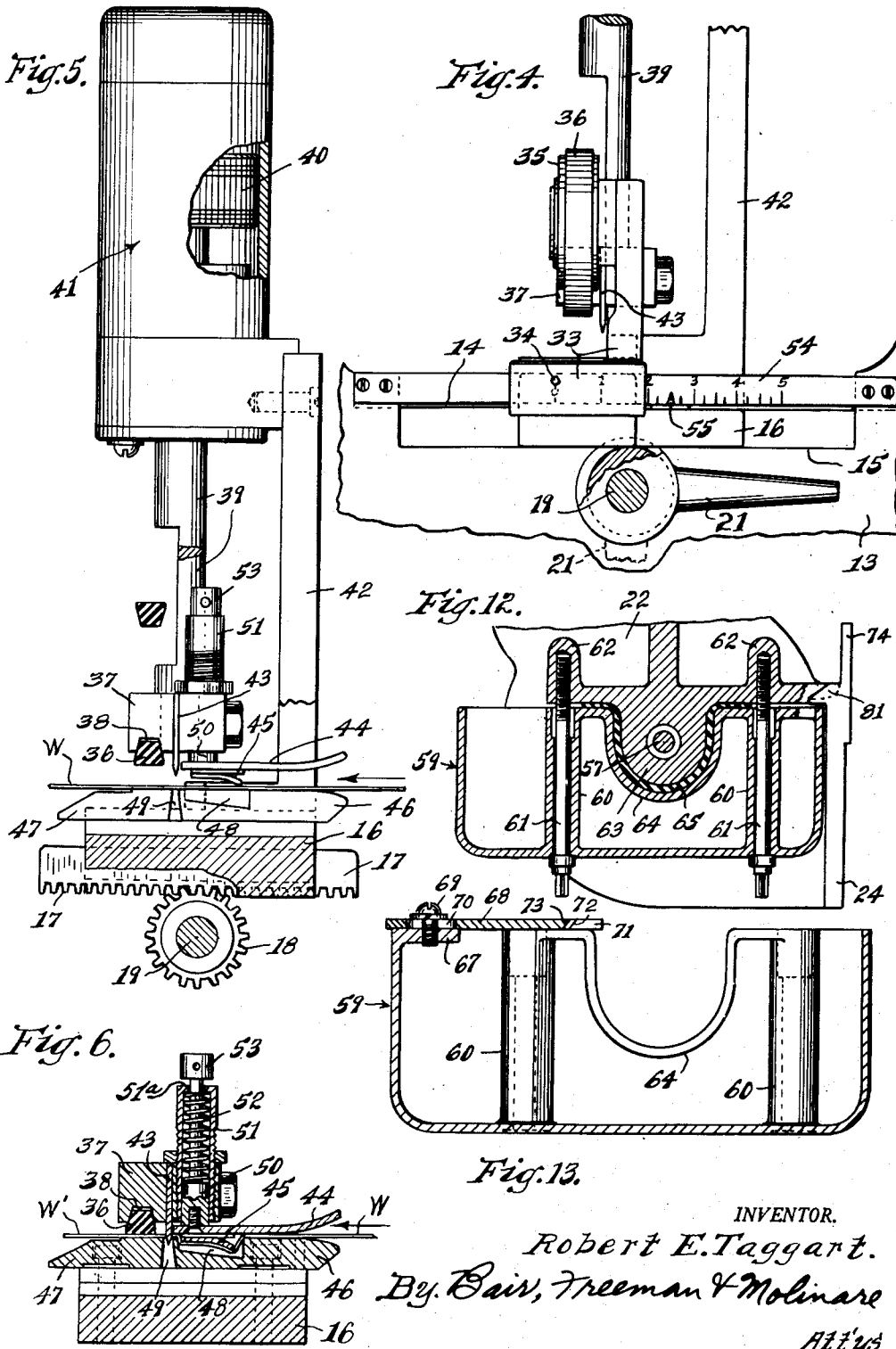

INVENTOR.

Robert E. Taggart.

By: Bair, Freeman & Molinare

Att'ys.

Nov. 17, 1953

R. E. TAGGART

2,659,341

GLUING ASSEMBLY FOR PACKAGING MACHINES

Filed Aug. 18, 1951

3 Sheets-Sheet 3

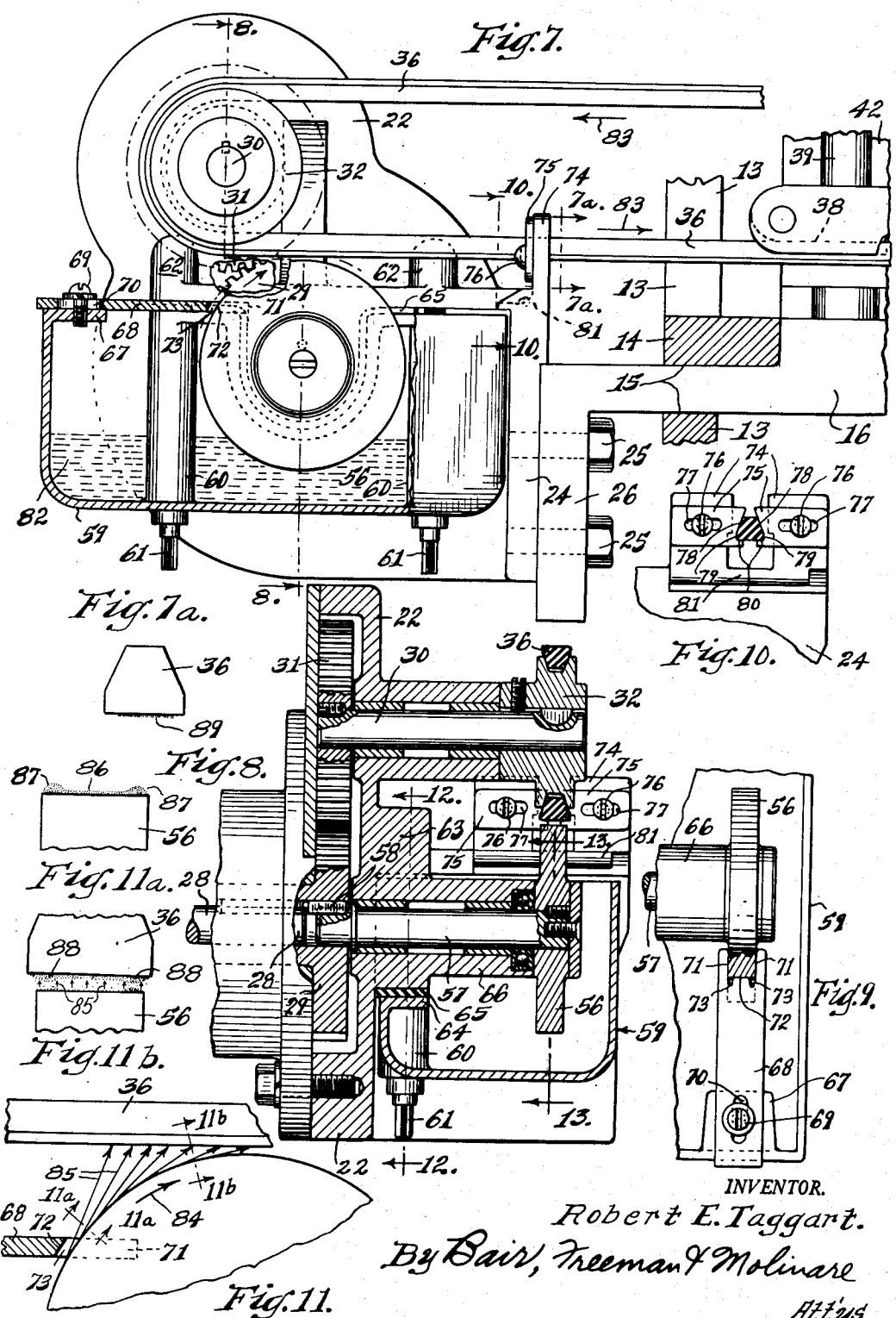

INVENTOR.
 Robert E. Taggart.
 By Bair, Freeman & Molinare
 Attys.

UNITED STATES PATENT OFFICE

2,659,341

GLUING ASSEMBLY FOR PACKAGING MACHINES

Robert E. Taggart, Toledo, Ohio, assignor to Lynch Corporation, Anderson, Ind., a corporation of Ohio

Application August 18, 1951, Serial No. 242,505

11 Claims. (Cl. 118—205)

1

This invention relates to a gluing assembly for a packaging machine of the kind shown in Stevens Patent No. 2,292,487 of August 11, 1942, and is an improvement in the details of the gluing assembly as disclosed in that patent and in the copending application of Doepel and Wiley, Serial No. 103,875, filed July 9, 1949.

One object of the present invention is to provide a gluing assembly for supplying glue to a pulley-supported, glue-applying belt which has a section thereof between the pulleys movable toward a wrapper for transferring glue on the belt to the wrapper, my improved gluing assembly featuring a readily removable gluepot which facilitates cleaning thereof as the pot may be removed at the end of the day's run and soaked in water for loosening any hardened glue so that it can be readily brushed out of the pot.

Another object is to provide a gluing assembly wherein glue is transferred from a glue-applying wheel to a glue-applying belt by centrifugal force as distinguished from actual contact of the wheel with the belt.

Still another object is to provide an improved form of glue-applying wheel scraper which produces two thickened lines of glue on the periphery of the wheel adjacent the sides thereof so that when this glue is thrown by centrifugal force on to the surface of the belt, it will be more evenly spread throughout the width of the belt.

A further object is to provide a scraper for the belt after the glue has been supplied thereto which scrapes the sides and the marginal edges of the glue-applying surface of the belt, thus leaving the central portion of the surface with the thickest layer of glue and the marginal edges substantially free of glue so that when the section of the belt between the rollers is subsequently moved toward a wrapper for transferring glue from the belt to the wrapper, the glue will be deposited in a definite line across the wrapper, tapering in thickness at the edges of the line of glue instead of being piled up adjacent the edges of such line as in previous constructions.

Still a further object is to provide a gluepot which is connected with and supported by a gear housing having a shaft and a glue-applying wheel projecting therefrom, the means of connection comprising a pair of screws that can be tightened to provide a glue-tight joint at a gasket strip between the gluepot and the gear housing or can be readily removed for permitting removal of the gluepot for soaking and cleaning purposes.

With these and other objects in view, my invention consists in the construction, arrangement

2

and combination of the various parts of my gluing assembly for packaging machines, whereby the objects contemplated are attained, as hereinafter more fully set forth, pointed out in my claims and illustrated in the accompanying drawings, wherein:

Figure 1 is a plan view of a gluing assembly and associated mechanism of a packaging machine, the gluing assembly embodying my present invention.

Figure 2 is an elevation of Figure 1 as viewed from the lower side of Figure 1.

Figure 3 is a perspective view of the removable gluepot of my present invention.

Figure 4 is an enlarged partial end view of the right hand end of Figure 2.

Figure 5 is an enlarged vertical sectional view on the line 5—5 of Figure 2 showing the means for moving a section of the glue-applying belt between its supporting pulleys toward a wrapper, the means being in the raised position.

Figure 6 is an enlarged vertical sectional view on the line 6—6 of Figure 2 showing the means of Figure 5 in the lowered position for holding one part of the wrapper while a knife blade cuts a wrapper therefrom, and the glue-applying belt applying glue to the wrapper being cut off.

Figure 7 is an enlarged vertical sectional view on the line 7—7 of Figure 1.

Figure 7a is an enlarged diagrammatic view on the line 7a—7a of Figure 7 showing the distribution of glue on the belt when it is ready to transfer glue to the wrapper.

Figure 8 is a vertical sectional view on the line 8—8 of Figure 7.

Figure 9 is an enlarged plan view showing a glue-applying wheel scraper illustrated in Figure 1 in the lower left corner thereof.

Figure 10 is a vertical sectional view on the line 10—10 of Figure 7 showing particularly scraper blades for the glue-applying belt.

Figure 11 is a diagrammatic view similar to a portion of Figure 7 showing the action of a glue-applying wheel throwing glue on the glue-applying belt by centrifugal force.

Figures 11a and 11b are diagrammatic views on the respective lines 11a—11a and 11b—11b of Figure 11 showing respectively the distribution of glue on the glue-applying wheel immediately following the scraping of the wheel by a scraper blade, and the transferring of glue from the wheel to the belt by centrifugal action.

Figure 12 is a sectional view on the line 12—12 of Figure 8; and

Figure 13 is a sectional view on the line 13—13

3

of Figure 8 showing only the gluepot and glue-applying wheel scraper which are part of the removable assembly.

On the accompanying drawings I have used the reference numeral 13 to indicate side frames of a packaging machine. Each side frame as shown in Figures 1 and 2 has a guide element 14. The lower edge of this element and the upper edge 15 of notches in the elements 13 form guide slots for a supporting bar 16.

The supporting bar 16 is adjustable horizontally along the side frames 13, the direction of adjustment being toward and from the observer in Figure 2. This is accomplished by means of a pair of racks 17 on the lower surface of the supporting bar 16 meshing with pinions 18 on an adjusting shaft 19. A hand wheel 20 is mounted on the shaft for rotating it, and a lock handle 21 is provided for retaining the adjustment once it is made. To indicate the degree of adjustment, a scale 54 is mounted on one of the side frames 13 as shown in Figure 4 and a pointer 55 on the supporting bar 16 cooperates therewith. The scale 54 may be graduated in inches or other suitable units to determine the proper setting of the gluing assembly depending upon the size of wrapper to be cut and glued.

Gear housings 22 and 23 are provided and they have a mounting flange 24 which is secured by bolts 25 to a depending arm 26 on the left hand end of the supporting bar 16 in Figure 2. A motor 27 is mounted on the gear housing 23 and through suitable gearing therein drives a shaft 28 (see Figure 8) which I shall term a "motor driven shaft." A gear 29 is mounted on the shaft 28 in the gear housing 22 and a second gear 31 mounted on a glue-applying belt pulley shaft 30 meshes therewith. A glue-applying belt pulley 32 is mounted on the shaft 30.

On the end of the supporting bar 16 opposite the depending arm 26, is a belt tightener bracket 33 provided with an adjusting screw 34 for belt tightening purposes. An idler pulley 35 is journaled on the bracket 33 and a glue-applying belt 36 is trained around the pulleys 32 and 35, as best shown in Figure 2.

The belt 36 travels in a groove 38 in the bottom of a belt depressing shoe 37 in the form of an elongated bar as shown in Figures 1 and 2. The shoe 37 is supported by a pair of piston rods 39 extending into cylinders 41 and provided therein with pistons 40 (see Figure 5). The cylinders in turn are mounted on cylinder mounting brackets 42 which are supported on the bar 16.

Also carried by the piston rods 39 is a wrapper severing knife 43 having a serrated lower edge as shown in Figure 2. A paper holding blade 44 and a paper depressing blade 45 are also carried by the piston rods 39. Wrapper supporting shoes 46 and 47 are mounted on the supporting bar 16 to support the wrapper material shown at W. The shoe 46 is provided with a groove 48 for the wrapper depressing blade 45 when in the lowered position shown in Figure 6. A slot 49 is provided between the shoes 46 and 47 to permit entry of the wrapper severing knife 43 as also shown in this figure.

The wrapper holding blade 44 and the wrapper depressing blade 45 are mounted for limited independent movement relative to the bar 16 by securing them to a pair of plungers 50 that are reciprocable in sleeves 51. In each sleeve a spring 52 is interposed between an intumed flange 51a at the upper end of the sleeve and the

4

upper end of the plunger to normally force the plunger downwardly to the position shown in Figure 5 with a head 53 on the plunger engaging the upper end of the sleeve. When the parts are lowered to the position of Figure 6, the blade 44 resiliently engages the wrapper W due to the action of the spring 52 as shown in this figure.

Returning to Figure 8, I provide a glue-applying wheel 56 mounted on a glue-applying wheel shaft 57. The shaft 57 is rotatable in a bearing 66 of the gear housing 22 and is connected by a key 58 to the gear 29 to be driven thereby.

Partially surrounding the glue-applying wheel 56 is a gluepot 59 of substantially rectangular shape (plan view). It is provided with two bosses 60 through which attaching bolts 61 extend and these are threaded into bosses 62 of the gear housing 22 as best shown in Figure 12. The gear housing 22 is also provided with a hub 63 which is substantially an enlarged part of the bearing 66, and the gluepot 59 has a flange 64 of substantially the same shape as the outer limits of this boss. Interposed between the two is a gasket strip 65 to prevent leakage of glue when the gluepot is mounted with respect to the gear housing 22. The gasket may be cemented to the hub 63. This arrangement permits ready removal of the gluepot as a unit (Figure 3) so that it can be soaked in water for loosening any hardened deposits of glue thereon and thus facilitate the cleaning of glue therefrom as by brushing to insure proper operation of the gluing assembly.

Referring to Figure 7, the gluepot 59 is provided with a mounting flange 67 on which is mounted a scraper blade 68. A clamp screw 69 serves to mount the blade, the screw extending through a slot 70 in the blade so that the blade can be adjusted toward or away from the glue-applying wheel 56.

Referring to Figure 9, the scraper blade 68 is provided with a scraper slot, the sides of which are indicated at 71 and the bottom at 72. The bottom 72 is provided with a pair of notches 73 as illustrated, which are adjacent the sides of the slot, with the bottom of the slot between the notches contacting the periphery of the wheel.

Referring to Figures 7 and 10, bracket ears 74 extend upwardly from the mounting flange 24 and support glue-applying belt scraper blades 75. Each blade is mounted by means of a clamp screw 76 extending through a slot 77 of the scraper blade and threaded into the bracket ear 74. Each scraper blade is provided with side, corner and marginal bottom scraping edges 78, 79 and 80 respectively. These fit the sides, corners and bottom margins of the glue-applying belt 36 as shown in Figure 10 for the purpose of scraping excess glue therefrom and leaving glue only on the bottom of the belt spaced inwardly from its side edges. The flange 24 as shown in Figure 7 is provided with a glue draining lip 81 back of the scraper blades 75 to receive glue therefrom scraped off the belt by the blades and return such glue to the gluepot 59.

Practical operation

In the operation of my gluing assembly for packaging machines, the gluepot 59 is mounted in position and filled with glue 82 to substantially the level shown in Figure 7. The motor 27 is energized which causes the glue-applying belt 36 to be propelled in the direction of the arrows 83 in Figure 7, and the glue-applying wheel 56 to be rotated clockwise in this figure, as indi-

cated by the arrow 84. The speed of rotation is such that centrifugal force will throw the glue off the wheel and on to the belt as indicated by the arrows 85 in Figure 11. Due to the peculiar shape of the slot 71—72—73 in Figure 9, the periphery of the wheel 56 as it leaves the slot of the scraper blade 68 will have a deposit of glue thereon substantially as shown in Figure 11a. There will be a very thin film of glue on the periphery between the marginal edges as shown at 86 and a relatively thicker layer of glue as indicated at 87 adjacent each marginal edge.

As a result of the glue deposit pattern illustrated by stippling in Figure 11a and just described, two thickened lines of glue 88 (see Figure 11b) will be thrown by centrifugal force onto the belt 35, and the size of the notches 73 is such that by the time a particular point on the wheel 56 reaches the closest approach to the belt 36, most of the glue will have been thrown off. This is illustrated by stippling in Figure 11b with only a little of the glue remaining on the wheel and most of it deposited on the belt, thickest along the lines 88 and to some extent between these lines, the glue, due to capillary action, tending to spread substantially evenly along the lower surface of the belt.

After the belt passes through the scraper blades 75, the deposit thereon will be substantially as shown at 89 in Figure 7a, that is, across the central portion of the belt but substantially scraped clean adjacent its marginal side edges. By the time the belt has traveled some little distance, however, this glue will tend to spread out and become thinner adjacent the marginal edges so that when the central section of the lower stretch of the belt is moved downwardly by the belt depressing shoe 37, it will deposit a line of glue on the wrapper W' which has been cut from the wrapper as in Figure 6, and the side edges of the glue will be feathered while the central portion will be thickest, which is a desirable distribution for proper gluing of the wrapper around the package.

At the end of a day's run, the gluepot 59 can be readily removed by removing the two screws 61 and dropping the gluepot down away from the hub 63. It can then be soaked in water and any dried glue loosened so that it can be readily cleaned out. In cases where the machine is operated continuously, gluepots can be alternately used and soaked between usings. This arrangement makes for easy cleaning of the pots because of the possibility of easily disconnecting them from the gluing assembly.

The wheel scraper and belt scraper arrangement herein described I have found particularly adaptable for the type of gluing operation disclosed. It is very effective to deposit a line of glue on the wrapper in exactly the manner that is best for performing the gluing operation when the glued flap of the wrapper is pressed against the package by the proper instrumentalities of the packaging machine.

Some changes may be made in the construction and arrangement of the parts of my gluing assembly for packaging machines without departing from the real spirit and purpose of my invention, and it is my intention to cover by my claims and modified forms of structure or use of mechanical equivalents which may be reasonably included within their scope.

I claim as my invention:

1. In a gluing assembly for a packaging machine having a glue-applying belt, means for

propelling said belt, and means for moving a section of the belt toward a wrapper for transferring glue from the belt to the wrapper; means for applying glue to said belt comprising a gluepot, a glue-applying wheel rotatable therein with its periphery projecting above the surface of the glue in said gluepot, a scraper for said wheel, said scraper having a slot receiving the peripheral margin of said wheel, the sides of said slot contacting the sides of the wheel and the bottom of the slot having notches adjacent the sides of said slot with the bottom of the slot between said notches substantially contacting the periphery of the wheel to scrape the same between said notches, said glue-applying wheel being spaced from said belt and being rotated by said first means to throw glue from the portion of said wheel receding from said scraper onto the belt by centrifugal force.

2. In a gluing assembly for a packaging machine having a glue-applying belt, means for propelling said belt, and means for moving a section of the belt toward a wrapper for transferring glue from the belt to the wrapper; means for applying glue to said belt comprising a gluepot, a glue-applying wheel rotatable therein with its periphery projecting above the surface of the glue in said gluepot, means for rotating said wheel, a scraper for said wheel, said scraper having a slot receiving the peripheral margin of said wheel, the sides of said slot contacting the sides of the wheel and the bottom of the slot having notches adjacent the sides of said slot, said wheel being spaced from said belt and being rotated at a speed to throw glue from said wheel onto the adjacent surface of the belt by centrifugal force.

3. A gluing assembly for a packaging machine having a pulley-supported glue-applying belt and means for moving a section of the belt between its supporting pulleys toward a wrapper for transferring glue from the belt to the wrapper; said gluing assembly comprising a gluepot, a glue-applying wheel of less width than said belt, means for rotating said wheel, said wheel rotating in said gluepot with its periphery projecting above the surface of the glue therein and spaced from said belt to throw glue onto the belt by centrifugal force, and a scraper for said wheel having a scraping surface provided with relieved portions adjacent the marginal edges of the wheel.

4. In a gluing assembly for a packaging machine having a glue-applying belt, means for propelling said belt, and means for moving a section of the belt toward a wrapper for transferring glue from the belt to the wrapper; means for applying glue to said belt comprising a bearing, a shaft extending therefrom and driven by said first means, a glue pot, said gluepot being removable relative to said bearing, a gasket between said gluepot and said bearing to prevent glue leakage, a glue-applying wheel mounted on said shaft and rotatable in said gluepot with its periphery projecting above the surface of the glue therein, a scraper for said wheel, said scraper having a slot receiving the peripheral margin of the wheel, the sides of said slot contacting the sides of the wheel and the bottom of said slot having notches adjacent the sides of said slot with the bottom of the slot between the notches substantially contacting the periphery of said wheel, said wheel being spaced from said glue belt and being rotatable by said shaft to throw glue from said wheel onto the belt by centrifugal force.

5. A gluing assembly for a packaging machine having a glue-applying V-belt, means for propelling said V-belt, and means for moving a section of said V-belt toward a wrapper for transferring glue from the belt to the wrapper; said gluing assembly comprising a boss, a shaft extending therefrom and driven by said first means, a glue pot, said gluepot being removable relative to said boss and having a portion to fit around it, a gasket strip between said portion and said boss to prevent glue leakage, a glue-applying wheel mounted on said shaft and rotatable in said gluepot with its periphery projecting above the surface of the glue therein, means for rotating said glue-applying wheel, a scraper therefor, and a scraper for the sides, corners and marginal edges of the glue receiving surface of said belt.

6. In a gluing assembly for a packaging machine having a glue-applying belt, means for propelling said belt, and means for moving a section of the belt toward a wrapper for transferring glue from the belt to the wrapper; means for applying glue to said belt comprising a boss, a shaft extending therefrom and driven by said first means, a glue pot, said gluepot being removable relative to said boss and having a portion to fit therearound, a gasket interposed between said portion and said boss to prevent glue leakage, a glue-applying wheel mounted on said shaft and rotatable in said gluepot with its periphery projecting above the surface of the glue therein, a scraper for said wheel, said wheel being spaced from said glue belt and being rotated by said shaft at a speed to throw glue from said wheel onto said belt.

7. In a gluing assembly for a packaging machine having a glue-applying V-belt, means for propelling said V-belt, and means for moving a section of the belt toward a wrapper for transferring glue from the belt to the wrapper; means for applying glue to said belt comprising a gluepot, a glue-applying wheel rotatable therein with its periphery projecting above the surface of the glue in said gluepot, a scraper for said wheel, said wheel being spaced from said belt, means for rotating said wheel at a speed sufficient to throw glue from said wheel onto the belt by centrifugal force, and a scraper for said V-belt comprising a scraper blade for each side thereof having a scraping surface fitting the side and extending inwardly along the marginal edge of the glue-receiving surface of the belt, thereby leaving the central portion of said surface unscraped.

8. A gluing assembly for a packaging machine having a glue-applying V-belt, means for propelling said V-belt, and means for moving a section of the belt toward a wrapper for transferring glue from the belt to the wrapper; said assembly comprising a gluepot, a glue-applying wheel rotatable therein with its periphery projecting above the surface of the glue in said gluepot, said wheel being spaced from said belt and being rotated by said first means to throw glue from said wheel onto the belt by centrifugal force, and a scraper for said V-belt comprising a scraper blade for each side thereof and for the inwardly extending marginal edges of the belt.

9. In a gluing assembly for a packaging ma-

chine having a glue-applying belt, means for propelling said belt, and means for moving a section of the belt toward a wrapper for transferring glue from the belt to the wrapper, means for applying glue to said belt comprising a gluepot, a glue-applying wheel rotatable therein with its periphery projecting above the surface of the glue in said gluepot, means for rotating said wheel to throw glue therefrom onto a glue-receiving surface of the belt by centrifugal force, and a scraper for said belt which scrapes the marginal edges of said surface and leaves the central portion thereof unscraped.

10. A gluing assembly for a packaging machine having a pulley-supported glue-applying belt and means for moving a section of the belt between its supporting pulleys toward a wrapper for transferring glue from the belt to the wrapper; said gluing assembly comprising a gluepot, a glue-applying wheel rotatable therein with its periphery projecting above the surface of the glue in said gluepot and spaced from said belt to throw glue onto the belt by centrifugal force, means for rotating said wheel, and a scraper for said belt comprising a scraper blade for each side thereof having a scraping surface fitting the side and extending inwardly along the marginal edge of the glued surface of the belt, thereby leaving the central portion of said surface unscraped.

11. In a gluing assembly for a packaging machine having a glue-applying belt, means for propelling said belt, and means for moving a section of the belt downwardly toward a wrapper for transferring glue from the belt to the wrapper; means for applying glue to the lower surface of said belt comprising a gluepot, a glue-applying wheel rotatable therein below said belt with its periphery projecting above the surface of the glue, said wheel being spaced below said belt and being rotated by said first means to throw glue onto the lower surface thereof by centrifugal force, the means for moving a section of the belt toward a wrapper comprising a belt-depressing shoe and means for engaging the wrapper material carried by said shoe and movable independently thereof, said last means comprising wrapper holding and depressing blades, plungers carrying said blades, sleeves receiving said plungers slidably, spring means urging said plungers toward the wrapper, said plungers being slidable against the bias of said spring means to resiliently engage said wrapper-holding blade with the wrapping material when the belt depressing shoe is in position for engaging the belt with the wrapper to transfer glue from the belt thereto.

ROBERT E. TAGGART.

References Cited in the file of this patent

UNITED STATES PATENTS

Number	Name	Date
2,022,521	Pierce	Nov. 26, 1935
2,078,223	Andrew	Apr. 27, 1937
2,292,487	Stevens	Aug. 11, 1942
2,371,031	Davis	Mar. 6, 1945