

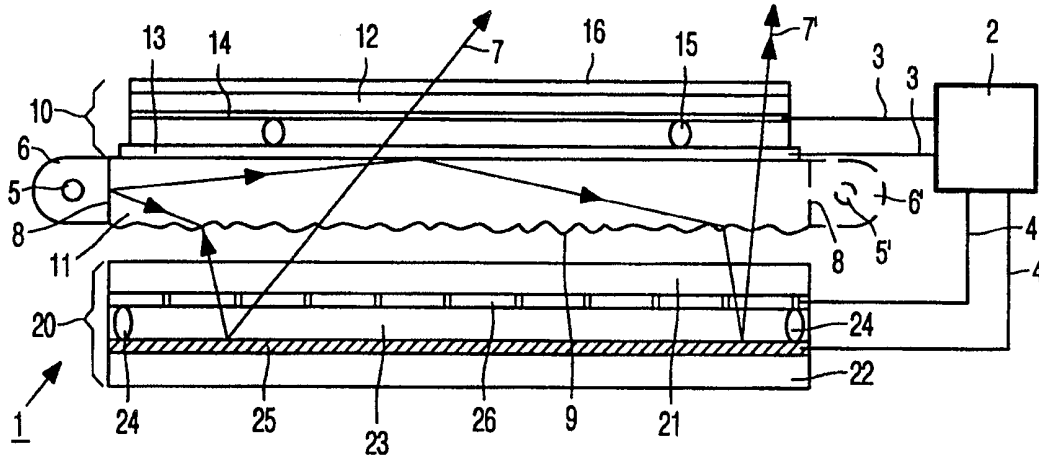

INTERNATIONAL APPLICATION PUBLISHED UNDER THE PATENT COOPERATION TREATY (PCT)

<p>(51) International Patent Classification ⁶ : G06K 11/06, G06F 3/033</p>	<p>A1</p>	<p>(11) International Publication Number: WO 99/53431 (43) International Publication Date: 21 October 1999 (21.10.99)</p>
<p>(21) International Application Number: PCT/IB99/00516 (22) International Filing Date: 25 March 1999 (25.03.99) (30) Priority Data: 98201134.8 9 April 1998 (09.04.98) EP (71) Applicant: FLAT PANEL DISPLAY CO. (FPD) B.V. [NL/NL]; Prof. Holstlaan 4, NL-5656 AA Eindhoven (NL). (72) Inventor: LEENHOUTS, Frans; Prof. Holstlaan 6, NL-5656 AA Eindhoven (NL). (74) Agent: RAAP, Adriaan, Y.; Prof. Holstlaan 6, NL-5656 AA Eindhoven (NL).</p>		<p>(81) Designated States: CN, JP, European patent (AT, BE, CH, CY, DE, DK, ES, FI, FR, GB, GR, IE, IT, LU, MC, NL, PT, SE). Published <i>With international search report.</i></p>

(54) Title: TOUCH SENSOR DISPLAY



(57) Abstract

In a touch panel display, a substrate (11) of the touch panel (10) of the touch panel itself is used as an optical guide for lighting a reflective display (20).

FOR THE PURPOSES OF INFORMATION ONLY

Codes used to identify States party to the PCT on the front pages of pamphlets publishing international applications under the PCT.

AL	Albania	ES	Spain	LS	Lesotho	SI	Slovenia
AM	Armenia	FI	Finland	LT	Lithuania	SK	Slovakia
AT	Austria	FR	France	LU	Luxembourg	SN	Senegal
AU	Australia	GA	Gabon	LV	Latvia	SZ	Swaziland
AZ	Azerbaijan	GB	United Kingdom	MC	Monaco	TD	Chad
BA	Bosnia and Herzegovina	GE	Georgia	MD	Republic of Moldova	TG	Togo
BB	Barbados	GH	Ghana	MG	Madagascar	TJ	Tajikistan
BE	Belgium	GN	Guinea	MK	The former Yugoslav Republic of Macedonia	TM	Turkmenistan
BF	Burkina Faso	GR	Greece			TR	Turkey
BG	Bulgaria	HU	Hungary	ML	Mali	TT	Trinidad and Tobago
BJ	Benin	IE	Ireland	MN	Mongolia	UA	Ukraine
BR	Brazil	IL	Israel	MR	Mauritania	UG	Uganda
BY	Belarus	IS	Iceland	MW	Malawi	US	United States of America
CA	Canada	IT	Italy	MX	Mexico	UZ	Uzbekistan
CF	Central African Republic	JP	Japan	NE	Niger	VN	Viet Nam
CG	Congo	KE	Kenya	NL	Netherlands	YU	Yugoslavia
CH	Switzerland	KG	Kyrgyzstan	NO	Norway	ZW	Zimbabwe
CI	Côte d'Ivoire	KP	Democratic People's Republic of Korea	NZ	New Zealand		
CM	Cameroon			PL	Poland		
CN	China	KR	Republic of Korea	PT	Portugal		
CU	Cuba	KZ	Kazakstan	RO	Romania		
CZ	Czech Republic	LC	Saint Lucia	RU	Russian Federation		
DE	Germany	LI	Liechtenstein	SD	Sudan		
DK	Denmark	LK	Sri Lanka	SE	Sweden		
EE	Estonia	LR	Liberia	SG	Singapore		

Touch sensor display.

The invention relates to a device comprising a sensor device with a detection device for determining information of at least a part of a surface of the sensor device, a display device comprising an electro-optical medium between two substrates, and a driver for driving the display device in dependence upon the information obtained via the detection device.

5 Devices of this type (also referred to as touch-panel displays) are generally known, in which different sensor mechanisms can be used. For determining information, it is possible to activate a part of the surface by scanning and measuring, for example activating via light (by means of, for example, a light pen) and by subsequently measuring induced currents or capacitively or resistively measuring electric voltages induced by pressure variation. The
10 displayed information may vary from the co-ordinates of the part of the surface to the luminescence of the relevant part or possibly a menu activated thereby in computer applications.

15 A device of the type mentioned in the opening paragraph is described in USP 5,194,862. For the sensor device described in this patent it is indicated how it can be used as an overlay for a liquid crystal display device (LCD).

 When this type of device is used, notably in portable applications (mini-notebook computers, personal digital assistance devices, telecommunication), it is desirable
20 that a minimal quantity of energy is used. A considerable part of the energy is used in the illumination source which is situated behind the display device.

 It is, inter alia, an object of the present invention to provide a device of the type described in which one or more of these problems are largely prevented. It is another object to provide such a device with a minimal volume.

25 To this end, a device according to the invention is characterized in that the device comprises, between the sensor device and the electro-optical medium, an optical guide of optically transparent material having a plurality of end faces, at least one of which is an entrance face for light, while light can be coupled in at said end face, and the side of the

optical guide facing the electro-optical medium constitutes an exit face for the light. The substrate of the sensor device preferably comprises the optical guide.

Since the device and particularly the sensor device comprises the optical guide, the latter is integrated therein and an illumination source (backlight) situated behind the electro-optical medium may be omitted. The entire device will thereby become more compact (flatter).

For a satisfactory coupling of the light from the optical guide to the electro-optical medium, the surface of the optical guide is preferably roughened or provided with a sawtooth structure or a substantially hemispheric structure on the side of the electro-optical medium.

The display device is preferably reflective. Such display devices make use of ambient light and are based on the use of a reflector or reflective electrodes. Since notably reflective LCDs are not sufficiently bright without the measure according to the invention in situations where there is little ambient light, transflective display devices (LCDs) are also used. In these devices, an illumination source (backlight) is situated behind the LCD while a transflector (transflective electrodes) is chosen instead of the reflector (the reflective electrodes). However, since the reflective power decreases, the optical quality of the image in the reflective mode is considerably reduced. Moreover, also in this case, it is necessary to arrange a backlight behind the electro-optical medium.

Another solution is the use of an extra light source at the front side (front light system). Here again, the total volume increases to such an extent that this is inadmissible, notably for said applications.

A preferred embodiment of a device according to the invention is characterized in that the substrate also comprises a substrate of the display device. The assembly will thereby become even more compact.

In a further embodiment, the substrate of the display device remote from the optical guide comprises a silicon substrate incorporating, for example, drive switches (active drive) or further drive functions.

These and other aspects of the invention are apparent from and will be elucidated with reference to the embodiments described hereinafter.

In the drawing:

Fig. 1 is a cross-section of a device according to the invention, and

Fig. 2 is a plan view of the sensor device and
Figs. 3 and 4 are variants of Fig. 1.

The Figures are diagrammatic and not drawn to scale. Corresponding
components are generally denoted by the same reference numerals.

5

Fig. 1 shows a device 1 (touch panel display) according to the invention with a
sensor device 10, in this example a pressure-sensitive device having a first transparent
substrate 11 and a second transparent substrate 12. Transparent conducting layers, for example
10 ITO layers 13, 14 which are contacted via metallization strips 18, 19 (Fig. 2), are provided on
the substrates 11, 12. In this example, the assembly is provided with a protective coating 16,
while the substrates are spaced apart by means of spacers 15. If the surface of the sensor
device 10 is touched with a pen, for example, at the position 17, while the connection
metallizations 19, 19' are, for example, connected to earth via connection lines 3, the
15 resistance between the connection metallizations 18, 18' changes. This change of resistance,
which is measured also via connection lines 3, is an indication of, for example the X co-
ordinate of position 17 which is stored in detection device 2. Similarly, the Y co-ordinate is
determined and stored. If necessary, these X and Y co-ordinates are processed and determine
drive signals which are applied to the display device 20 via connection lines 4. In this
20 embodiment, the display device 20 is a reflective liquid crystal display device (LCD)
comprising twisted nematic liquid crystal material 23 which is present between two substrates
21, 22 of, for example glass, provided with reflecting electrodes 25 of, for example aluminum,
and light-transmissive ITO electrodes 26. The assembly is sealed by means of a sealing edge
24. If necessary, the display device further comprises one or more polarizers and orientation
25 layers (not shown) which orient the liquid crystal material on the inner walls of the substrates.

Information about the position 17 (the position where the sensor device is
activated) is processed in the detection device (which also functions as a processing unit) to an
image to be displayed (a luminescing pixel, a functional icon or a computer menu). Instead of
the mechanism described above, the detection device may also be based on a matrix of light-
30 sensitive elements which are activated by means of a light pen as used in, for example the
device described in said USP 5,194,862.

According to the invention, the substrate 11 of the sensor device also functions
as a front light for the LCD 20 for the case where the visibility of the displayed image is
insufficient due to insufficient ambient light. To this end, the substrate 11 is implemented as

an optical guide of an optically transparent material having a number of end faces 8, while the side 9 of the optical guide facing the electro-optical medium 23 (hence the display device 20) constitutes an exit face for the light. To this end, a lamp 5 from which light can be coupled in at said end face is accommodated in a lamp housing 6 opposite at least one end face 8. If

5 necessary, lamps, diagrammatically indicated by means of the reference numerals 5', 6', may be arranged at more end faces.

In order to enhance the coupling of the light rays 7, 7' from the lamp 5, the surface 9 of the substrate 11 facing the LCD 20 is roughened or is provided with the sawtooth structure or a substantially hemispheric structure.

10 A substrate 11 having a sawtooth structure is shown in Fig. 3 in which the substrate 11 also functions as substrate 21 of the display device. Such a sawtooth structure (in one direction or two mutually perpendicular directions) is provided on, for example a flat glass substrate by means of replica techniques. The device of Fig. 3 has become even more compact than that of Fig. 1. The reference numerals in Fig. 3 have the same significance as those in Fig.

15 2.

PDLC material has been chosen for the layer 23 of electro-optical material; in this case, polarizers are superfluous.

Fig. 4 is a cross-section of a part of a device according to the invention in which the exit face of the optical guide 31 between the sensor device 10 and the display device 20 has a hemispheric structure (spherical or cylindrical surface). In practice, the projections are slightly flattened or deviate in another sense from the ideal hemispheric or cylindrical structure.

25 Other modes of coupling out the light to the display device are alternatively feasible, such as benefiting in the correct manner from the side of the substrate 11 facing the sensor device, or by providing this substrate with cavities or light-scattering centers.

In another embodiment, the coupling-out is realized by the spacers 15 or by adapting (hemispheric structure) the other surface of the substrate 11 or the substrate 12 or the coating 16. In that case, the total sensor device functions as an optical guide.

30 Although reflecting electrodes 25 have been shown, they may be alternatively transmissive when a reflector is situated on the other side of the substrate 22. Instead of an LCD display device, other reflective display devices may be used alternatively.

A silicon substrate 22 in which, for example drive electronics is realized by means of IC technology, may also be used.

CLAIMS:

1. A device comprising a sensor device with a detection device for determining information of at least a part of a surface of the sensor device, a display device comprising an electro-optical medium between two substrates, and a driver for driving the display device in dependence upon the information obtained via the detection device, characterized in that the device comprises, between the sensor device and the electro-optical medium, an optical guide of optically transparent material having a plurality of end faces, at least one of which is an entrance face for light, while light can be coupled in at said end face, and the side of the optical guide facing the electro-optical medium constitutes an exit face for the light.
2. A device as claimed in claim 1, characterized in that a substrate of the sensor device comprises the optical guide.
3. A device as claimed in claim 1, characterized in that the surface of the optical guide is roughened on the side of the electro-optical medium.
4. A device as claimed in claim 1, characterized in that the surface of the optical guide is provided with a sawtooth structure or a substantially hemispheric structure on the side of the electro-optical medium.
5. A device as claimed in claim 1, characterized in that the device is provided with a light source opposite the end face.
6. A device as claimed in claim 1, characterized in that the substrate also comprises a substrate of the display device.
7. A device as claimed in claim 6, characterized in that the substrate of the display device remote from the optical guide comprises a silicon substrate.

8. A device comprising a sensor device with a detection device for determining information of at least a part of a surface of the sensor device, a display device comprising an electro-optical medium between two substrates, and a driver for driving the display device in dependence upon the information obtained via the detection device, characterized in that the
- 5 sensor device comprises an optical guide of optically transparent material having a plurality of end faces, at least one of which is an entrance face for light, while light can be coupled in at said end face, and the side of the optical guide facing the electro-optical medium constitutes an exit face for the light.

1/1

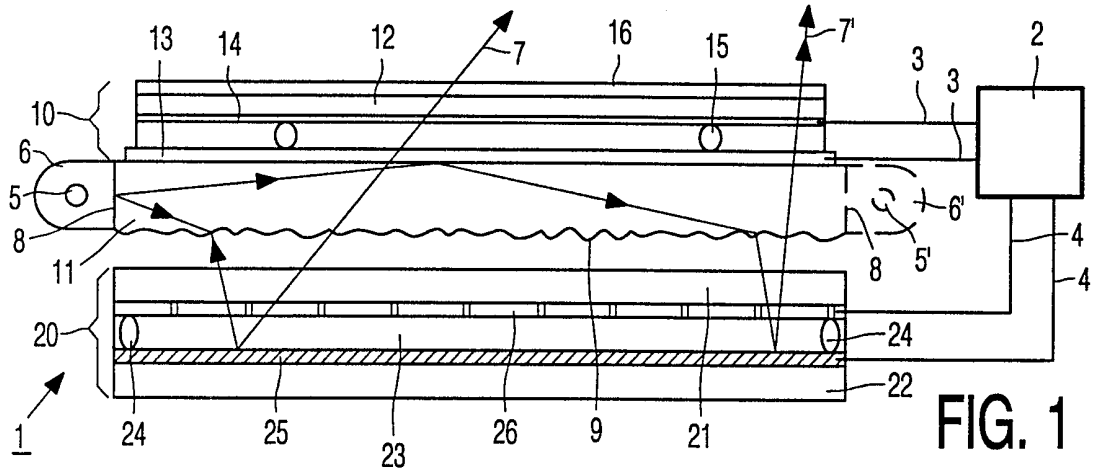

FIG. 1

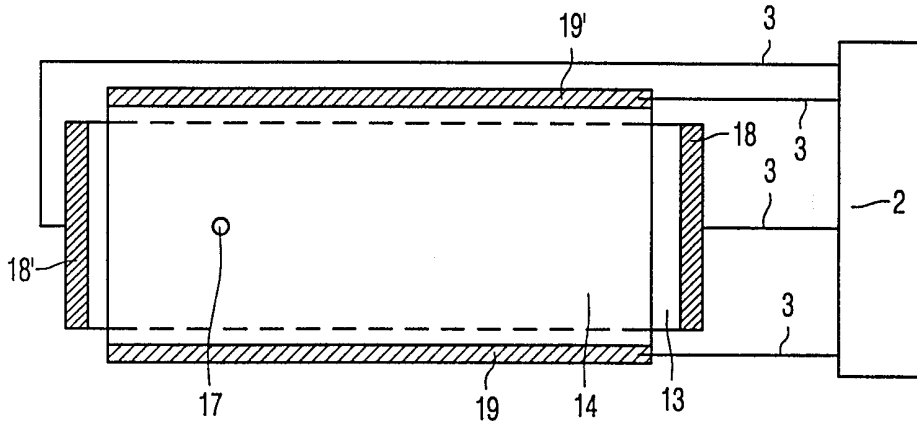

FIG. 2

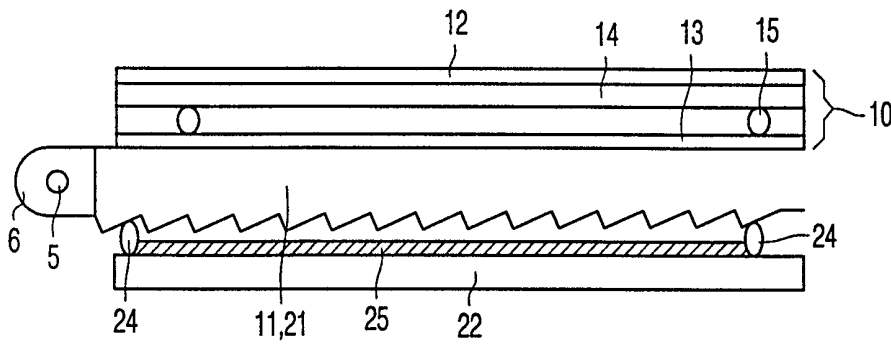

FIG. 3

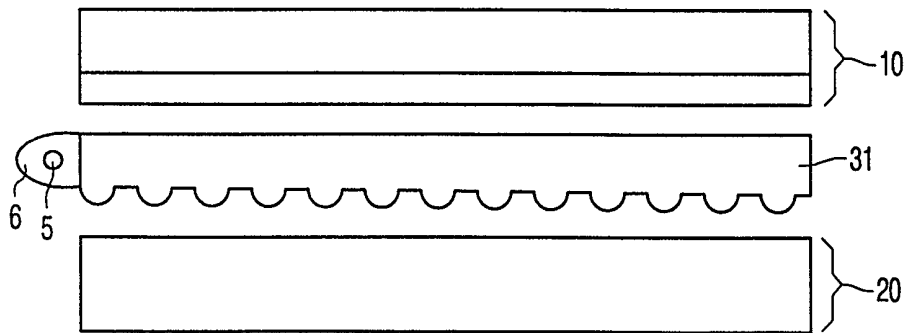

FIG. 4

INTERNATIONAL SEARCH REPORT

International Application No
PCT/IB 99/00516

A. CLASSIFICATION OF SUBJECT MATTER IPC 6 G06K11/06 G06F3/033		
According to International Patent Classification (IPC) or to both national classification and IPC		
B. FIELDS SEARCHED		
Minimum documentation searched (classification system followed by classification symbols) IPC 6 G06K G06F		
Documentation searched other than minimum documentation to the extent that such documents are included in the fields searched		
Electronic data base consulted during the international search (name of data base and, where practical, search terms used)		
C. DOCUMENTS CONSIDERED TO BE RELEVANT		
Category ^o	Citation of document, with indication, where appropriate, of the relevant passages	Relevant to claim No.
X	US 5 278 545 A (STRECK DONALD A) 11 January 1994 see column 5, paragraph 2 - paragraph 3 see column 6, paragraph 2 - column 7, line 32 see figures 12-14	1,2,5,8
X	EP 0 495 199 A (IBM) 22 July 1992 see column 4, paragraph 2; figure 2	1,8
A	US 5 359 155 A (HELSEY GEORGE) 25 October 1994 see abstract see figures 1,2	1,3,8

-/--		
<input checked="" type="checkbox"/> Further documents are listed in the continuation of box C.		
<input checked="" type="checkbox"/> Patent family members are listed in annex.		
^o Special categories of cited documents :		
"A" document defining the general state of the art which is not considered to be of particular relevance "E" earlier document but published on or after the international filing date "L" document which may throw doubts on priority claim(s) or which is cited to establish the publication date of another citation or other special reason (as specified) "O" document referring to an oral disclosure, use, exhibition or other means "P" document published prior to the international filing date but later than the priority date claimed		
"T" later document published after the international filing date or priority date and not in conflict with the application but cited to understand the principle or theory underlying the invention "X" document of particular relevance; the claimed invention cannot be considered novel or cannot be considered to involve an inventive step when the document is taken alone "Y" document of particular relevance; the claimed invention cannot be considered to involve an inventive step when the document is combined with one or more other such documents, such combination being obvious to a person skilled in the art. "&" document member of the same patent family		
Date of the actual completion of the international search	Date of mailing of the international search report	
30 June 1999	06/07/1999	
Name and mailing address of the ISA	Authorized officer	
European Patent Office, P.B. 5818 Patentlaan 2 NL - 2280 HV Rijswijk Tel. (+31-70) 340-2040, Tx. 31 651 epo nl, Fax: (+31-70) 340-3016	Ciarelli, N	

INTERNATIONAL SEARCH REPORT

International Application No
PCT/IB 99/00516

C.(Continuation) DOCUMENTS CONSIDERED TO BE RELEVANT

Category	Citation of document, with indication, where appropriate, of the relevant passages	Relevant to claim No.
A	US 5 178 447 A (MURASE SHINZO ET AL) 12 January 1993 see column 2, paragraph 3 - paragraph 4; figures 1-9 -----	1,3,8

INTERNATIONAL SEARCH REPORT

Information on patent family members

International Application No

PCT/IB 99/00516

Patent document cited in search report	Publication date	Patent family member(s)	Publication date
US 5278545 A	11-01-1994	NONE	
EP 0495199 A	22-07-1992	CA 2056676 A JP 5127828 A	19-07-1992 25-05-1993
US 5359155 A	25-10-1994	EP 0649552 A WO 9422120 A	26-04-1995 29-09-1994
US 5178447 A	12-01-1993	JP 4218089 A DE 4120950 A FR 2668845 A GB 2247309 A, B KR 9505210 B	07-08-1992 24-12-1992 07-05-1992 26-02-1992 22-05-1992