



US 20110132920A1

(19) **United States**

(12) **Patent Application Publication**
Petocchi et al.

(10) **Pub. No.: US 2011/0132920 A1**

(43) **Pub. Date: Jun. 9, 2011**

(54) **INTERLEAVED TOWEL DISPENSER**

(52) **U.S. Cl. 221/45**

(76) **Inventors: Ermanno Petocchi, Versailles, KY (US); Howard Carter, Frankfort, KY (US)**

(21) **Appl. No.: 12/653,272**

(57) **ABSTRACT**

(22) **Filed: Dec. 9, 2009**

An interleaved towel dispenser including a housing and a separation arrangement that facilitates the separation of individual towels of a stack of interleaved towels during dispense. The stack of interleaved towels further having an adhesive area that permits attachment of the stack of interleaved towels to another stack of interleaved towels.

Publication Classification

(51) **Int. Cl. B65D 83/08 (2006.01)**

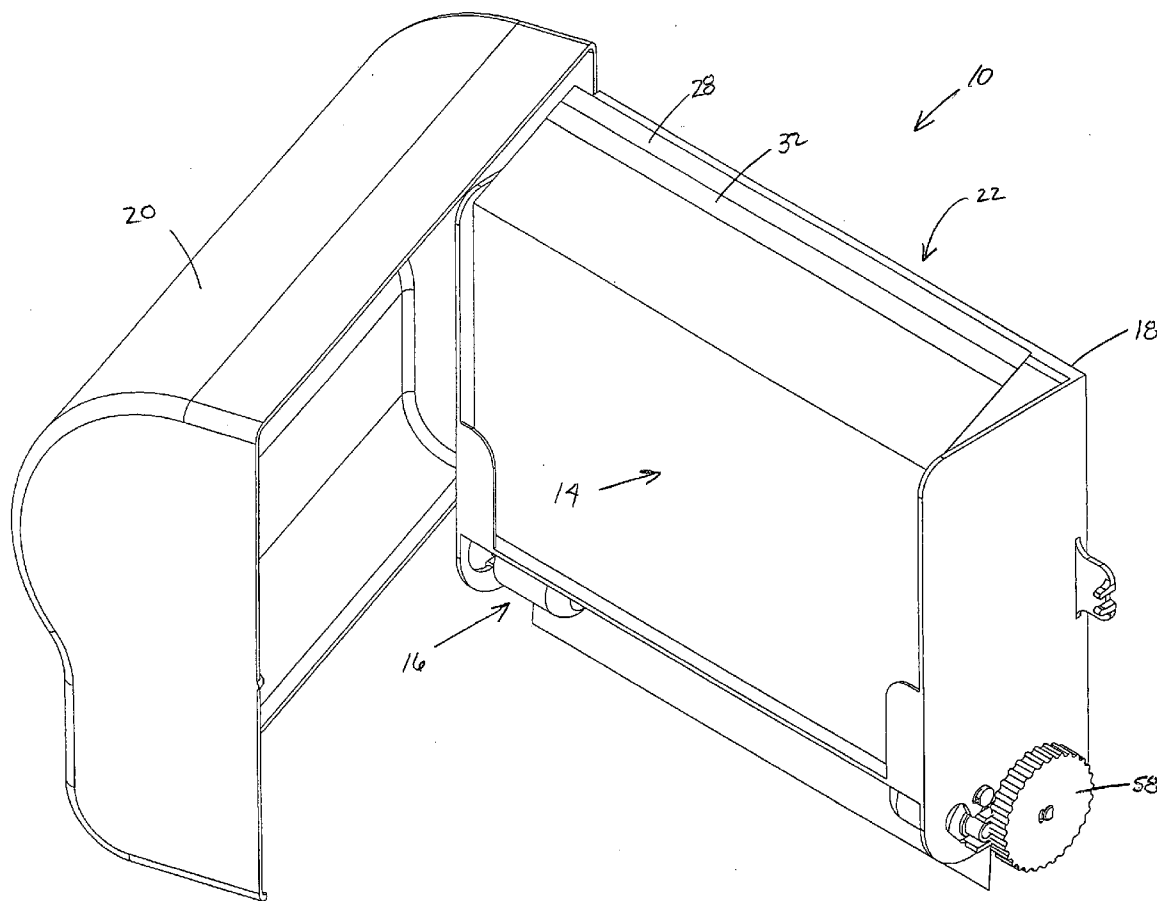
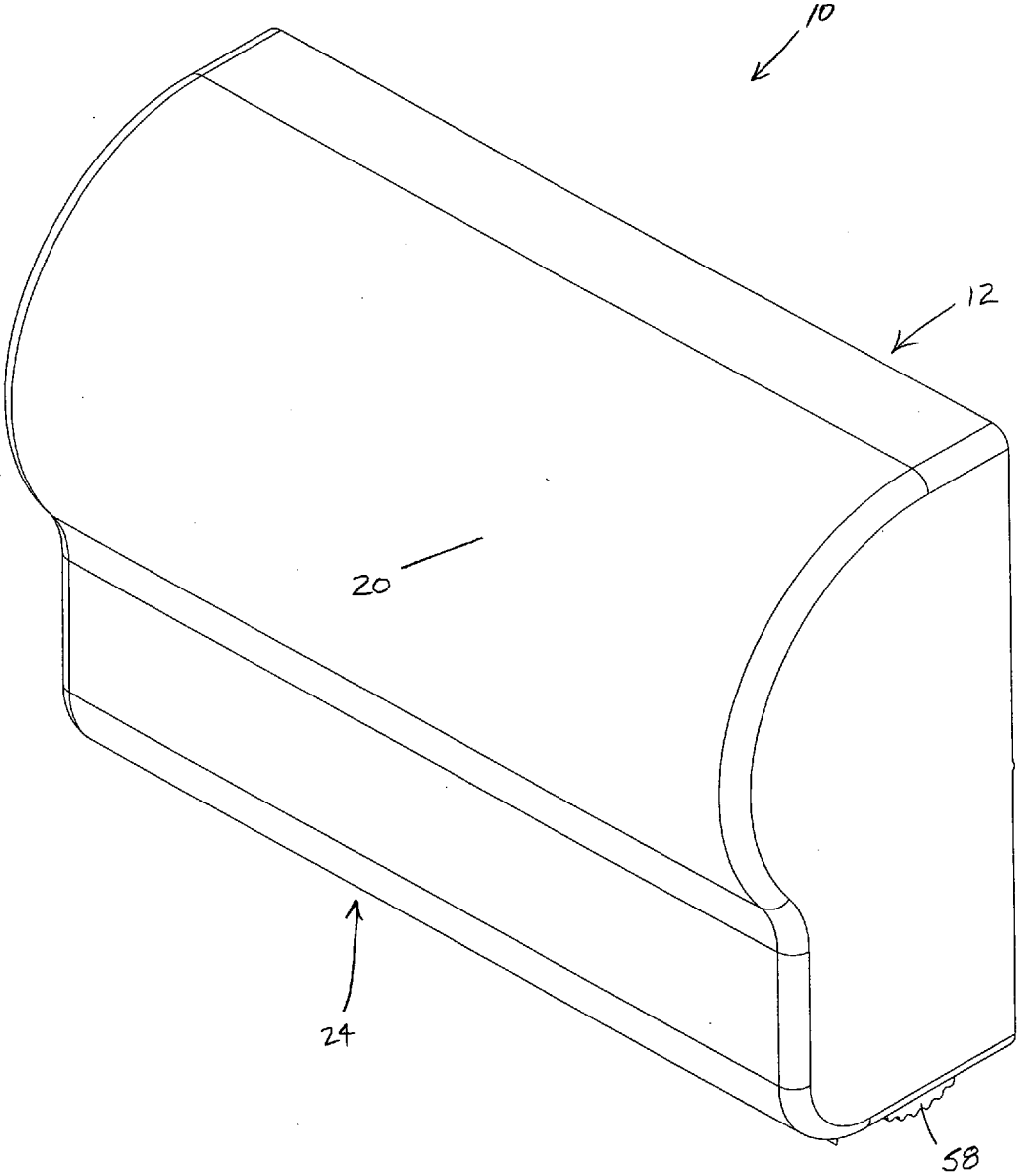

FIG. 1



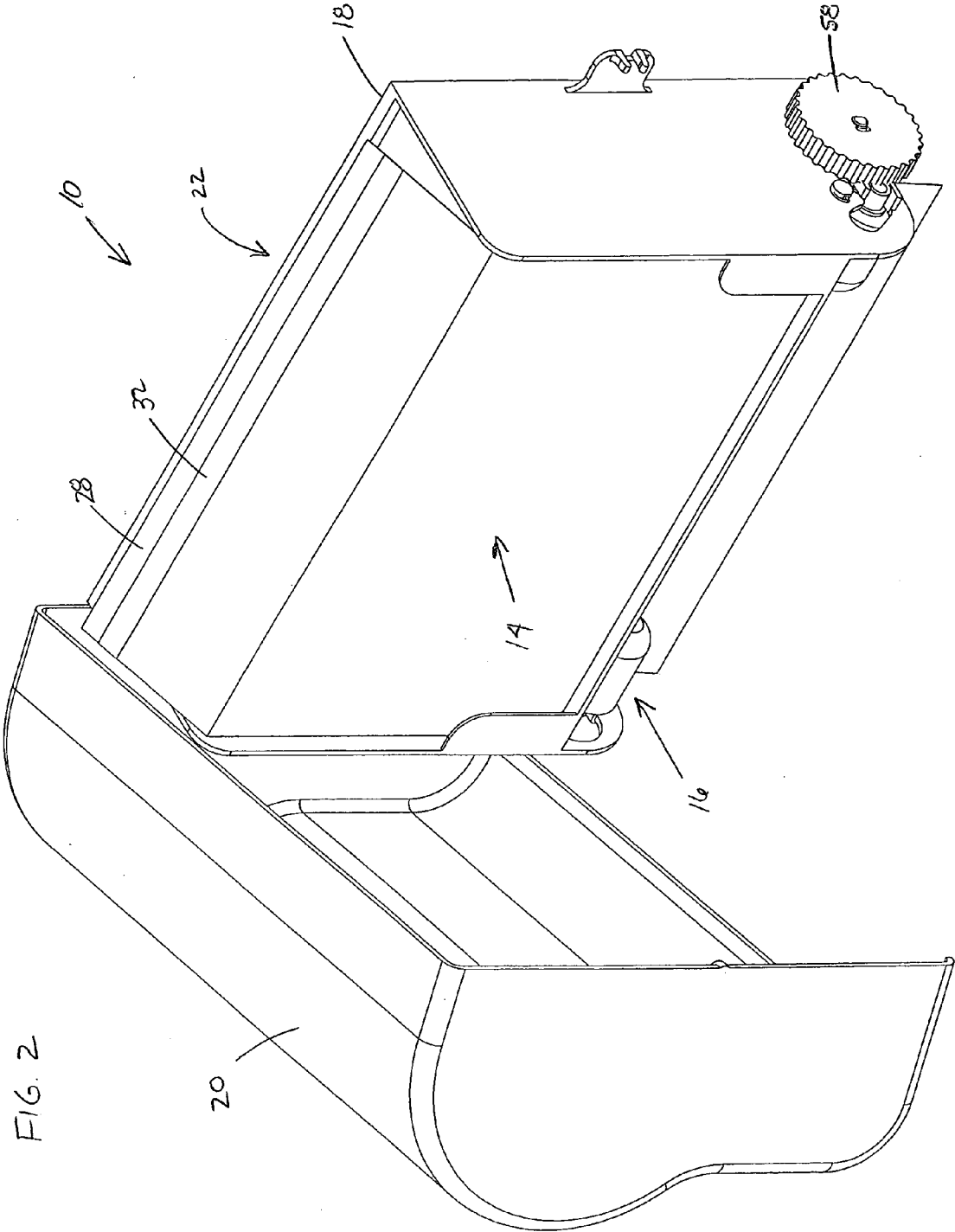

FIG. 3

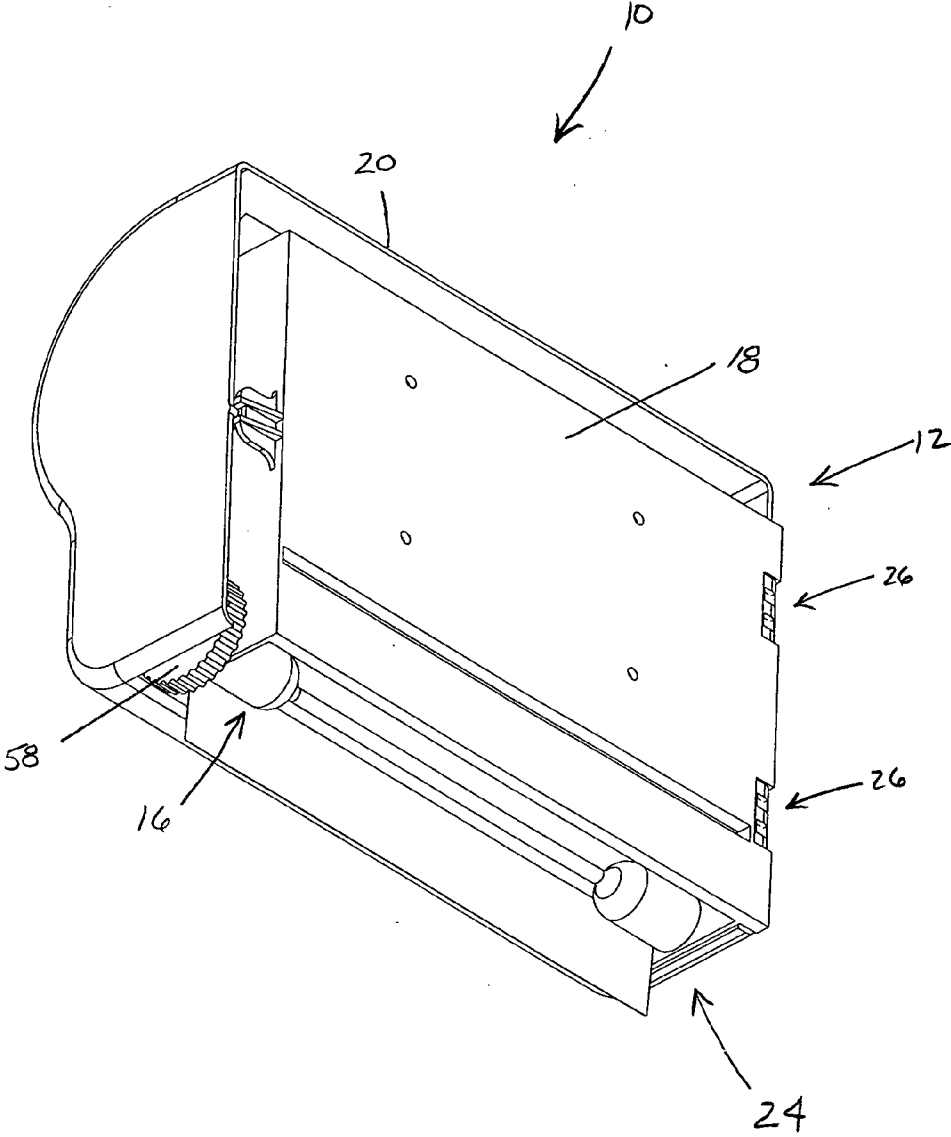

FIG. 4

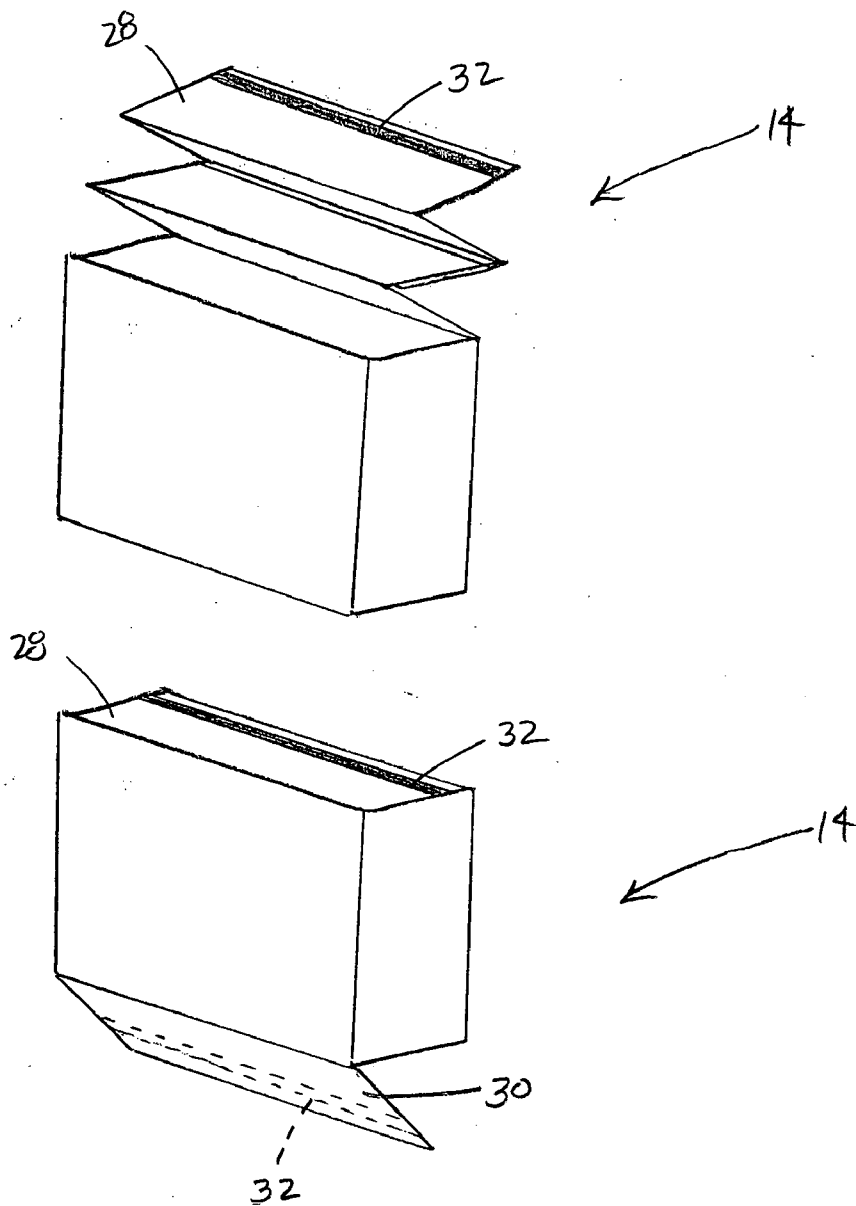
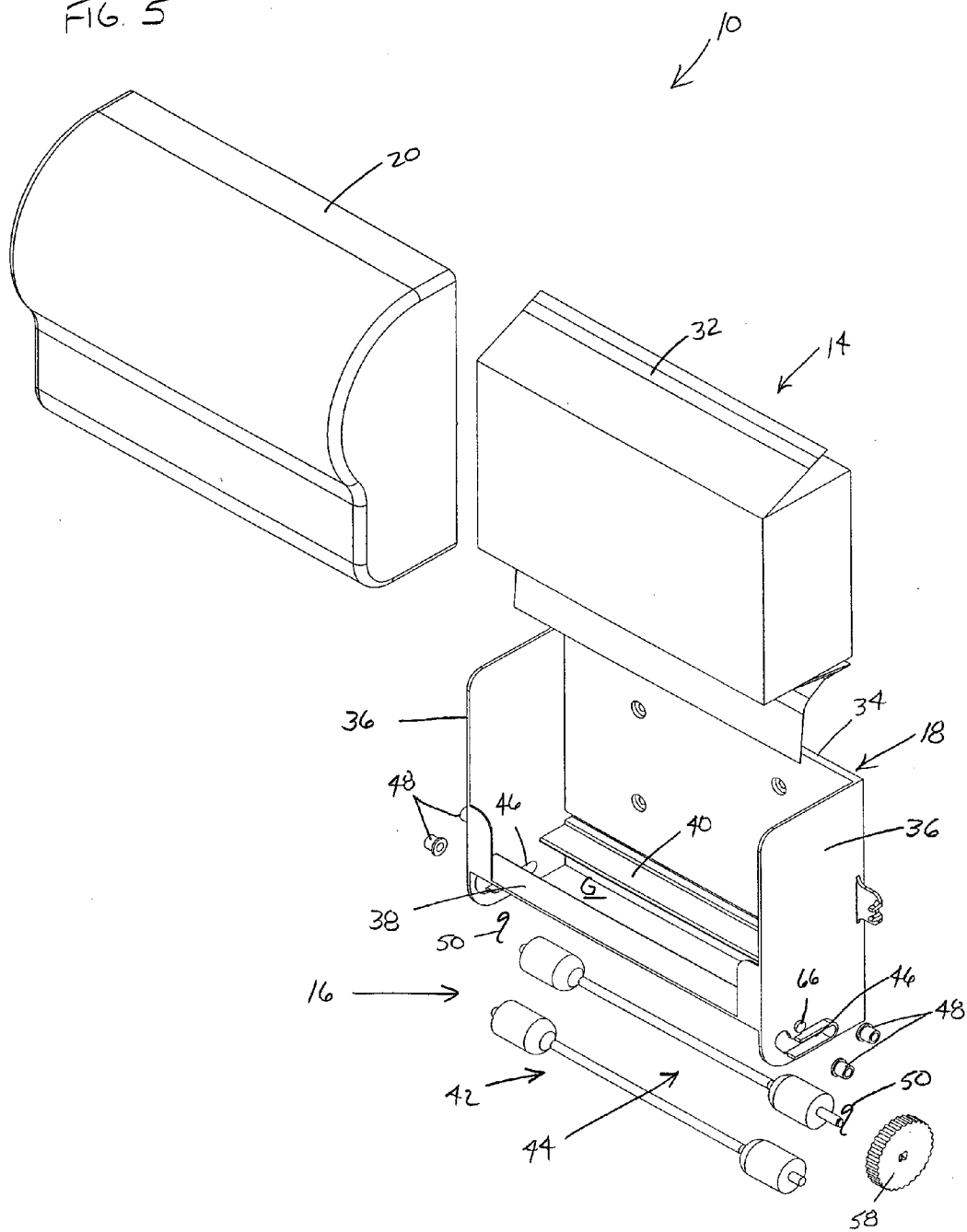

FIG. 5



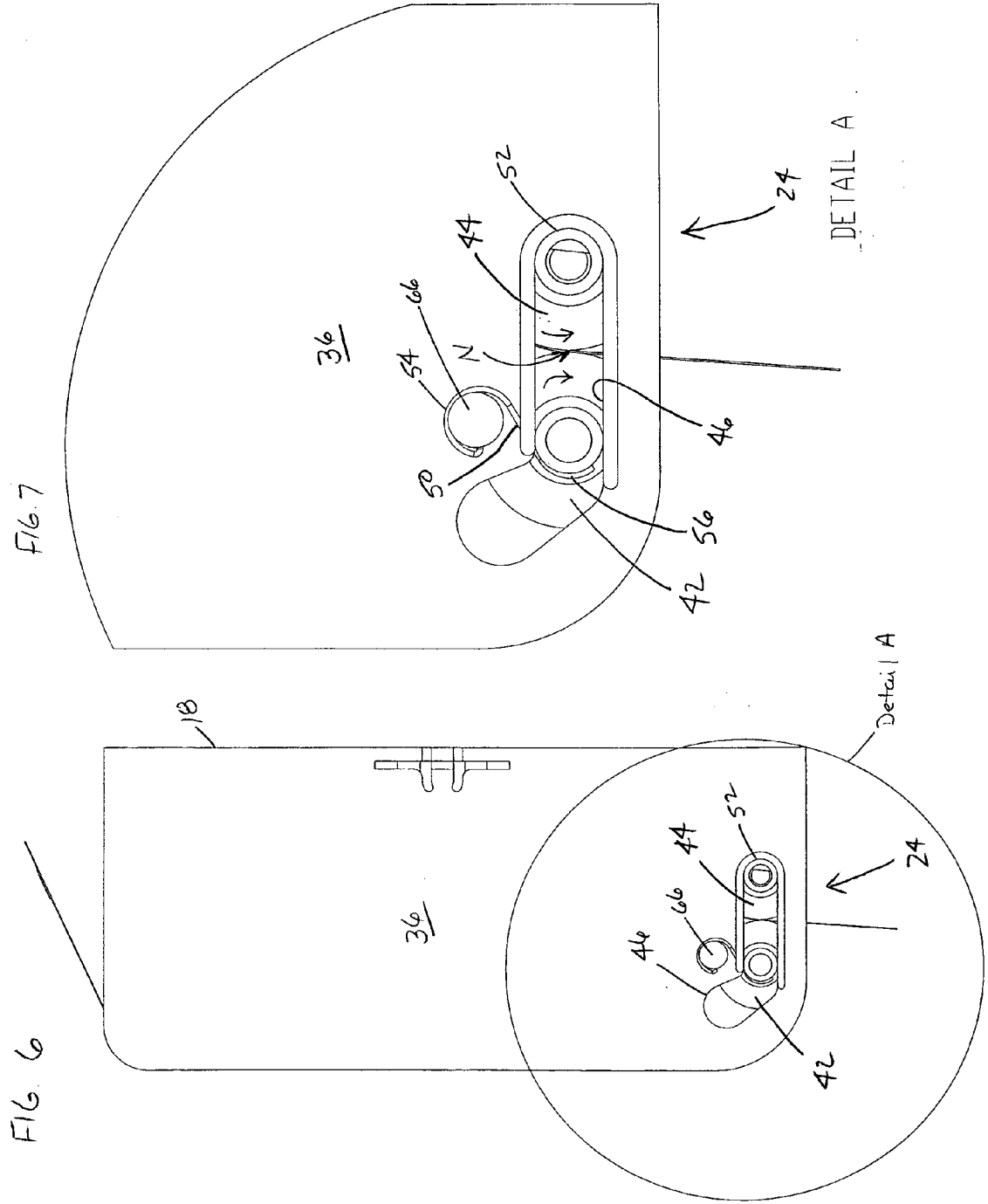

FIG. 8

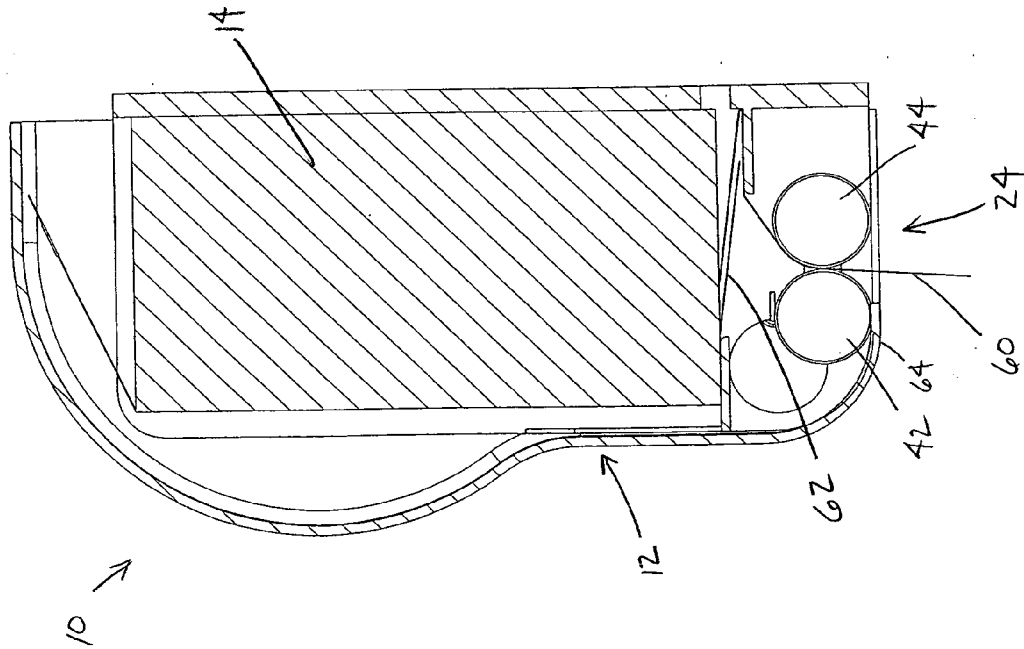

FIG. 9

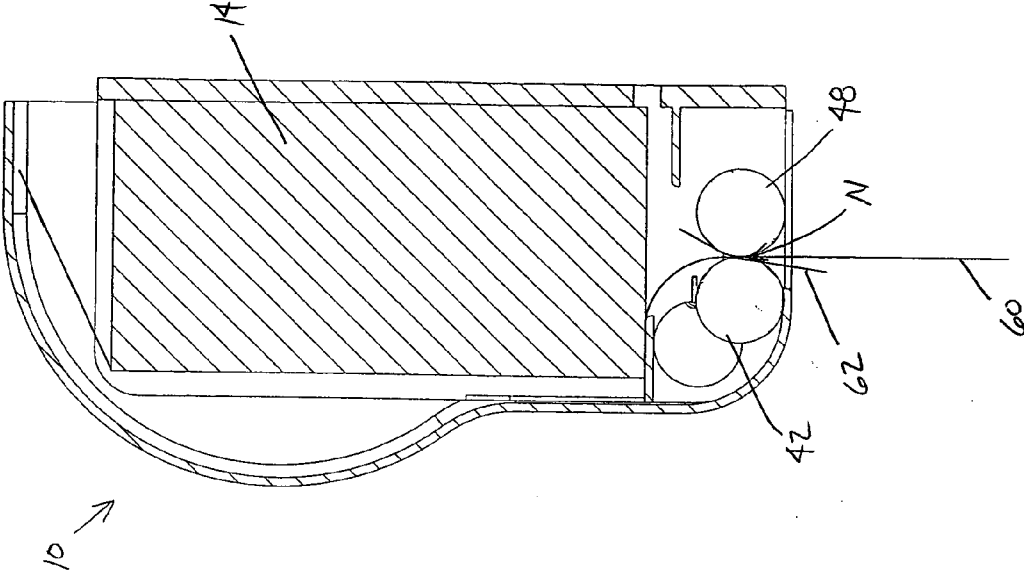

FIG. 10

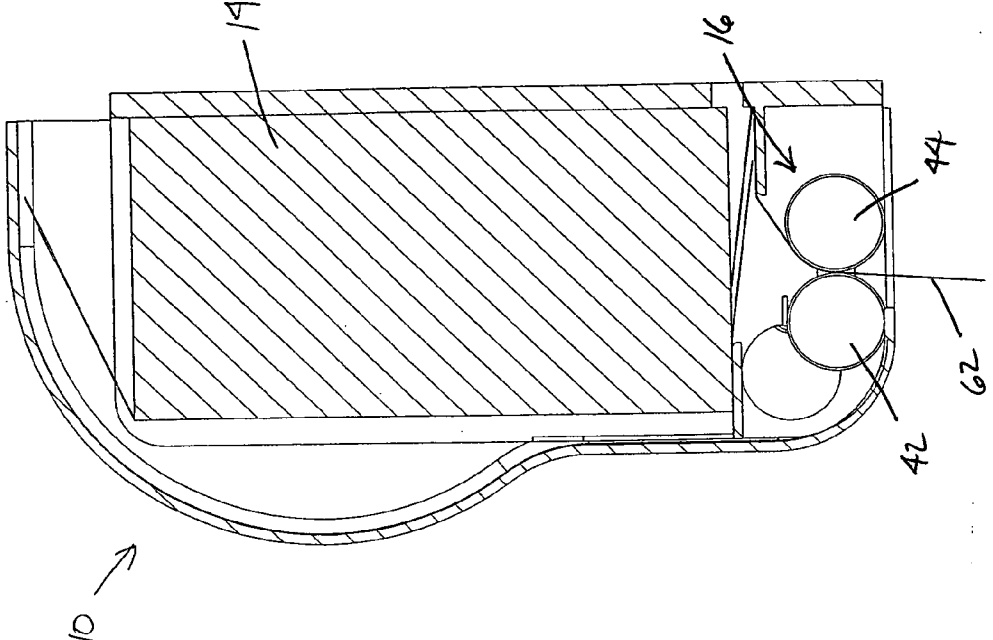
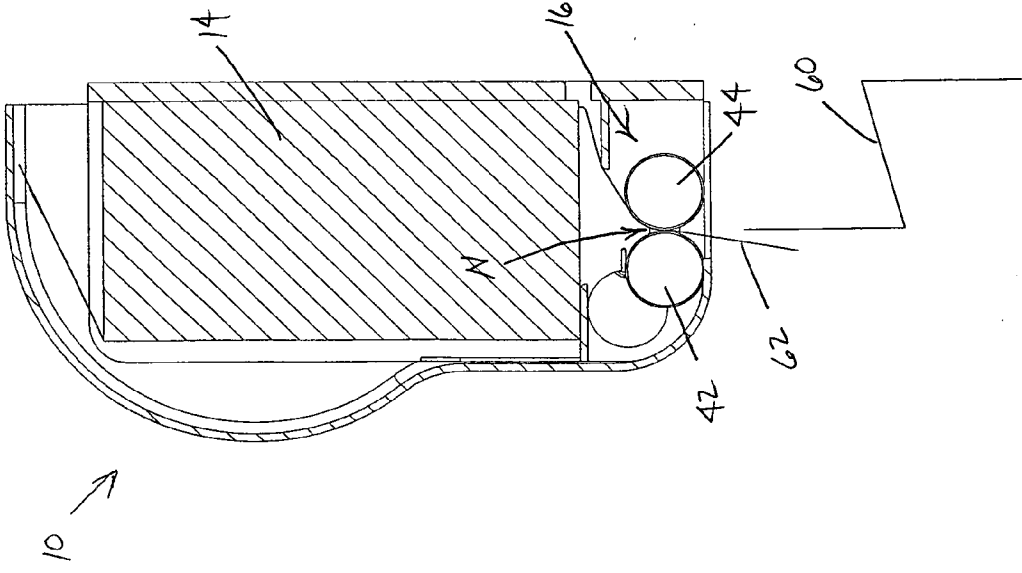

FIG. 10



INTERLEAVED TOWEL DISPENSER

FIELD OF THE TECHNOLOGY

[0001] The present disclosure relates generally to a towel dispensing device, and various methods associated with such a device. More particularly, this disclosure relates to a towel dispenser that dispenses interleaved towels, and various methods associated with such an interleaved towel dispenser.

BACKGROUND

[0002] A variety of paper towel dispensing arrangements currently exists. One common arrangement includes a paper towel dispenser having pre-folded, interleaved paper towels or sheets that are pulled from an opening in the dispenser. The paper towels are interleaved so that a tab of a second following paper towel is delivered when a first paper towel is pulled from the dispenser.

[0003] In conventional interleaved dispenser arrangements, multiple interleaved paper towels are sometimes dispensed at once without the user intending to take or use more than one towel. This over-dispense of multiple paper towels can be due simply to the interleaved arrangement of the towels, or by the user inadvertently grasping more than one sheet of paper towel at a time (e.g., by pinching together and pulling multiple paper towels at one time). The extra paper towels dispensed are often discarded without use, or left on the restroom sink, for example, where the extra towels can become wet and possibly contaminated.

[0004] Improvements to interleaved paper towel dispensers, generally to eliminate waste of paper towels and provide a user with an easy to use device, is needed.

SUMMARY

[0005] One aspect of the present invention relates to an interleaved towel dispenser that permits dispense of only one interleaved towel at a time. In use, a first towel is held by a separating arrangement and is accessible to a user through an opening in the dispenser. When the first towel is grasped and pulled, a second following towel interleaved with the first towel is drawn toward the opening. The separating arrangement retains the second following towel such that the first towel being pulled separates from the second towel. The first towel is released or dispensed to the user; the second following towel is retained, but is accessible for use.

[0006] A variety of examples of desirable product features or methods are set forth in part in the description that follows, and in part will be apparent from the description, or may be learned by practicing various aspects of the disclosure. The aspects of the disclosure may relate to individual features as well as combinations of features. It is to be understood that both the foregoing general description and the following detailed description are explanatory only, and are not restrictive of the claimed invention.

BRIEF DESCRIPTION OF THE DRAWINGS

[0007] FIG. 1 is a front perspective view of a towel dispenser, in accordance with the principles disclosed;

[0008] FIG. 2 is a front perspective view of the towel dispenser of FIG. 1, illustrated with an opened front cover;

[0009] FIG. 3 is a rear perspective view of the towel dispenser of FIG. 1;

[0010] FIG. 4 is a perspective view of two interleaved stacks of towels that can be used in the towel dispenser of FIG. 1;

[0011] FIG. 5 is an exploded, front perspective view of the towel dispenser of FIG. 1;

[0012] FIG. 6 is a side elevation view of the towel dispenser of FIG. 1, illustrated without the front cover;

[0013] FIG. 7 is an enlarged side elevation view of a portion of the towel dispenser of FIG. 6;

[0014] FIG. 8 is a cross-sectional view of the towel dispenser of FIG. 1, illustrated with a first interleaved towel awaiting use;

[0015] FIG. 9 is a cross-sectional view of the towel dispenser of FIG. 8, illustrated with the first interleaved towel being removed from the towel dispenser;

[0016] FIG. 10 is a cross-sectional view of the towel dispenser of FIG. 9, illustrated with the first interleaved towel removed from the towel dispenser; and

[0017] FIG. 11 is a cross-sectional view of the towel dispenser of FIG. 10, illustrated with a second interleaved towel awaiting use.

DETAILED DESCRIPTION

[0018] Reference will now be made in detail to exemplary aspects of the present disclosure that are illustrated in the accompanying drawings. Wherever possible, the same reference numbers will be used throughout the drawings to refer to the same or like parts.

[0019] In interleaved towel dispensers, the interleaving of the individual towels is relied upon to deliver a leading portion or tab of a following towel. In conventional arrangements, however, a clump of multiple towels are sometimes delivered from a single pull of a towel tab.

[0020] The present disclosure relates to an interleaved towel dispenser that meters or controls dispense of interleaved towels. As previously described, such conventional interleaved towel dispensers often dispense more individual towels than what is needed by a single user, resulting in towel waste and/or mess. The extra dispensed towels are sometimes left out in the open, for example upon a sink ledge, where the extra towels can become wet and/or contaminated. The present towel dispenser eliminates unintended dispensing of paper towels by delivering a single towel from a stack of interleaved towels. The towel dispenser can be constructed for installation within an existing towel dispenser frame, can be constructed to mount within a recessed space of a wall, and/or can be constructed to mount flush to a wall.

[0021] Referring now to FIGS. 1 and 2, the towel dispenser 10 generally includes a housing 12, a plurality of interleaved towels 14, and a separating arrangement 16 (see also FIG. 3) that dispenses only one interleaved towel from the housing 12 at a time. The housing 12 defines a bottom opening 24 (see also FIG. 3) through which the interleaved towels are dispensed.

[0022] The housing 12 of the towel dispenser 10 generally includes a frame 18 and a cover 20. The cover 20 is pivotally connected to the frame 18 at hinge locations 26 (FIG. 3). The cover 20 provides access to an interior 22 of the housing 12 when pivoted to an open position (for loading of the interleaved towels 14, for example), and generally encloses the contents of the interior of the housing 12 when pivoted to a closed position.

[0023] The plurality of interleaved towels 14 of FIG. 2 includes a stack of pre-cut individual paper towels. The indi-

vidual towels can be single fold or multifold. Referring to FIG. 4, two stacks of interleaved towels 14 are illustrated in isolation. Each stack of individual towels 14 has a top interleaved towel 28 and a bottom interleaved towel 30. A bonding material 32, such as an adhesive material, is provided on one or both of the top interleaved towel 28 and the bottom interleaved towel 30. In conventional arrangements, it is often difficult or time consuming to attempt to interleave a top towel of an existing stack with the bottom towel of a new stack when replenishing a dispenser; instead the new stack is simply placed upon the existing stack.

[0024] When the existing stack is depleted, a user is required to reach up within the dispenser to attempt to grasp the leading tab of the bottom towel of the new stack. In the present arrangement, the adhesive material 32 connects two stacks of interleaved towels 14 to automatically continue towel dispense without requiring a user to reach within the dispenser to manually re-establish a leading towel tab.

[0025] In the illustrated embodiment of FIG. 2, the adhesive material 32 is provided on an area of the top towel 28 of the stack of individual towels 14. In FIG. 4, a second optional or alternative adhesive area is shown in dashed line on the bottom towel 30. The adhesive material/area can include or be defined by a double-sided adhesive strip or a volume of adhesive material deposited on the particular towel, for example. Additional details of stacks of paper material incorporating adhesive material for attachment to other paper material stacks are described in U.S. patent application Ser. No. 12/582,189, which application is incorporated in its entirety herein by reference.

[0026] Referring now to FIG. 5, an exploded view of the towel dispenser 10 is illustrated. The frame 18 of the housing has a back panel 34 and opposing side panels 36. Two support shelves, including a forward support shelf 38 and a rearward support shelf 40 extend between the side panels 36. The support shelves 38, 40 support the stack of interleave towels 14 when loaded and stored within the interior of the housing. The support shelves 38, 40 are spaced apart so as to define a gap G between the shelves. The interleave towels 14 feed through the gap G to the bottom opening 24 of the housing during use.

[0027] Referring now to FIGS. 5-7, the separating arrangement 16 of the present dispenser 10 includes a first roller 42 and a second roller 44. The first and second rollers 42, 44 are located adjacent to the bottom opening 24 of the housing 12. The first roller 42 is a front roller located toward a front of the housing 12 and the second roller 44 is a rear roller located toward a rear of the housing 12. Opposite ends of each of the first and second rollers 42, 44 are positioned and supported within a slot 46 formed in each of the side panels 36 of the frame 18. The rollers 42, 44 rotate in the direction shown by arrows (FIG. 7) during dispense of a towel. Bushings or bearings 48 can be assembled onto the rollers 42, 44 to aid in the rotational movement of the rollers 42, 44.

[0028] The rollers 42, 44 are arranged to provide a nip area N (FIG. 7) between the rollers. In particular, one of the first and second rollers 42, 44 is biased toward the other roller by springs 50; the other roller being located at a fixed location relative to the frame 18. In the illustrated embodiment, the second roller 44 is located at the fixed location (i.e., at an end 52 of the slot 46) while the springs 50 bias the first roller 42 toward the second roller 44. Referring to FIG. 7, the springs 50 each have a first end portion 54 and a second end portion 56. The first end portions 54 of the springs 50 interconnect to

a fastening element 66 located on the respective side panels 36 of the frame 18. The second end portions 56 of the springs 50 bias the first roller 42 rearward against the second roller 44. In use, the force or “nip” provided between the rollers 42, 44 by the springs 50 retains individual towels of the stacked interleaved towels 14, as will be described in greater detail hereinafter. In an alternative embodiment, other devices or methods that create a nip area can be used in lieu of springs.

[0029] Referring to FIGS. 2, 3 and 5, the interleaved dispenser 10 further includes an advancement device 58 (such as a wheel or gear) interconnected to one of the first and second rollers 42, 44. The advancement device 58 advances a leading interleaved towel of the stack of interleaved towels through the nip area N of the rollers 42, 44 toward the bottom opening 24 when the dispenser 10 is initially loaded.

[0030] Referring now to FIG. 8, a cross-section of the interleaved towel dispenser 10 is illustrated. The stack of interleaved towels 14 is schematically shown with a first towel 60 awaiting use and a second following towel 62 interleaved with the first towel 60. The first and second rollers 42, 44 of the separating arrangement 16 retain the first towel 60 in an awaiting-use position until removed by a user. When positioned in the awaiting-use position, the individual towel (e.g., first towel 60) is visible to the user. That is, the awaiting use towel (e.g., 60) extends through the bottom opening 24 of the housing 12 such that a leading portion of the awaiting-use towel is located below an exterior 64 of the housing.

[0031] When the first towel 60 is pulled for removal, the first and second rollers 42, 44 rotate for dispense of the first towel; the second following towel 62 interleaved with the first towel 60 is pulled or drawn along with the first towel toward the bottom opening of the housing. Referring to FIG. 9, during such removal of the first towel 60, both the first towel 60 and the second following towel 62 become located within the nip area N between the first and second rollers 42, 44. Referring to FIG. 10, once the rollers 42, 44 have rotated by the pulling action on the first towel to a position at which the first towel is no longer in the nip area N of the rollers, the first towel 60 is released; the second following towel 62 however is retained by the “nip” between the rollers. In particular, the second following towel 62 is now retained in the awaiting-use position, as shown in FIG. 11.

[0032] The separating arrangement retains the second following towel such that the first towel being pulled separates from the second towel. That is, by allowing release of a first towel (e.g., 60) and by retaining a second following towel (e.g., 62) during removal of the first towel, the separating arrangement 16 facilitates separation of the towels and allows dispense of only one interleaved towel at a time. Further, the present dispenser 10 makes accessible to the user only the awaiting-use towel (e.g., 60 (FIG. 8) or 62 (FIG. 11)). That is, a user cannot inadvertently grasp or pinch together multiple towels. By this arrangement, towels are dispensed one by one to eliminate unintended towel waste. If additional toweling is needed, the user can simply obtain the following awaiting-use towel from the interleaved towel dispenser as previously described.

[0033] The above specification provides a complete description of the present invention. Since many embodiments of the invention can be made without departing from the spirit and scope of the invention, certain aspects of the invention reside in the claims hereinafter appended.

What is claimed is:

1. An interleaved towel dispenser, comprising:
 - a) a housing having an interior and an exterior;
 - b) a plurality of interleaved towels located within the interior of the housing, the plurality of interleaved towels including a first towel awaiting use and a second following towel interleaved with the first towel; and
 - c) a separating arrangement that permits dispense of only one interleaved towel at a time, wherein:
 - i) only the first towel awaiting use is accessible to a user; and
 - ii) the second following towel is retained during removal of the first towel.
2. The interleaved towel dispenser of claim 1, wherein the separating arrangement includes a first roller and a second roller that retain the first towel in an awaiting-use position and that retain the second following towel during removal of the first towel.
3. The interleaved towel dispenser of claim 2, wherein a leading portion of the first towel awaiting use extends below the exterior of the housing.
4. The interleaved towel dispenser of claim 2, wherein the first towel and the second towel are located between the first and second rollers during removal of the first towel.
5. The interleaved towel dispenser of claim 2, wherein the first roller is a front roller located toward a front of the housing, and the second roller is a rear roller located toward a rear of the housing.
6. The interleaved towel dispenser of claim 5, wherein one of the front and rear rollers is biased toward the other of the front and rear rollers to retain an awaiting-use towel of the plurality of interleaved towels therebetween.
7. The interleaved towel dispenser of claim 6, wherein the front roller is biased toward the rear roller by a spring.
8. The interleaved towel dispenser of claim 1, wherein the housing includes a frame and a cover pivotally attached to the frame, the cover providing access to the interior of the housing when pivoted to an open position.
9. The interleaved towel dispenser of claim 1, wherein the plurality of interleaved towels includes a stack of interleaved towels, the stack having a top interleaved towel and a bottom interleaved towel, one of the top and bottom interleaved towels having an adhesive area.
10. The interleaved towel dispenser of claim 1, wherein the housing defines a bottom opening through which the plurality of interleaved towels are dispensed, the first towel awaiting use being visible to a user.
11. The interleaved towel dispenser of claim 10, wherein the separating arrangement includes a first roller and a second roller, the interleaved dispenser further including an advancement device interconnected to one of the first and second rollers, wherein the advancement device advances a leading interleaved towel of the plurality of interleaved towels toward a bottom opening in the housing when the dispenser is initially loaded.
12. The interleaved towel dispenser of claim 11, wherein the advancement device is an advancement wheel attached to one of the first and second rollers.
13. An interleaved towel dispenser, comprising:
 - a) a housing having an interior and an exterior;
 - b) a first roller and a second roller; and
 - c) a plurality of interleaved towels located within the interior of the housing, the plurality of interleaved towels including a first towel and a second towel;
 - d) wherein the first towel is located between the first and second rollers when awaiting use, a leading portion of the first towel extending below the exterior of the housing when awaiting use;
 - e) wherein the first towel and the second towel are located between the first and second rollers during removal of the first towel;
 - f) wherein the first and second rollers retain the second towel therebetween during removal of the first towel.
14. The interleaved towel dispenser of claim 1, wherein the housing includes a frame and a cover pivotally attached to the frame, the cover providing access to the interior of the housing when pivoted to an open position.
15. The interleaved towel dispenser of claim 1, wherein the plurality of interleaved towels includes a stack of interleaved towels, the stack having a top interleaved towel and a bottom interleaved towel, one of the top and bottom interleaved towels having an adhesive area.
16. The interleaved towel dispenser of claim 1, wherein the first roller is a front roller located toward a front of the housing, and the second roller is a rear roller located toward a rear of the housing.
17. The interleaved towel dispenser of claim 16, wherein one of the front and rear rollers is biased toward the other of the front and rear rollers to retain an awaiting-use towel of the plurality of interleaved towels therebetween.
18. The interleaved towel dispenser of claim 17, wherein the front roller is biased toward the rear roller by a spring.
19. The interleaved towel dispenser of claim 1, further including an advancement device interconnected to one of the first and second rollers, wherein the advancement device advances a leading interleaved towel of the plurality of interleaved towels toward a bottom opening in the housing when the dispenser is initially loaded.
20. An interleaved towel dispenser, comprising:
 - a) a housing including a frame and a cover attached to the frame, the housing having an interior and a bottom opening, the frame including horizontal support shelves that define a gap therebetween, the support shelves being constructed to support a stack of interleaved paper towels; and
 - b) first and second rollers positioned within the interior of the housing adjacent to the bottom opening, the second roller being supported in a fixed position, the first roller being biased toward the second roller, the first and second rollers defining a nip area therebetween.
21. The interleaved towel dispenser of claim 20, further including a stack of interleaved paper towels placed upon the support shelves of the housing, the stack of interleaved paper towels including a first towel and a second towel interleaved with the first towel:
 - i) wherein the first towel is located within the nip area between the first and second rollers when awaiting use, a portion of the first towel extending below the exterior of the housing when awaiting use;
 - ii) wherein the first towel and the second towel are located within the nip area between the first and second rollers during removal of the first towel;
 - iii) wherein the first and second rollers retain the second towel therebetween during removal of the first towel.
22. The interleaved towel dispenser of claim 20, wherein the cover is pivotally attached to the frame, the cover providing access to the interior of the housing when pivoted to an open position.

23. The interleaved towel dispenser of claim 20, further including an advancement device interconnected to one of the first and second rollers, wherein the advancement device advances a leading interleaved towel of a plurality of inter-

leaved towels through the nip area when the interleaved towels are initially loaded within the interior of the housing.

* * * * *