

O. L. SMITH.
Dumping Car.

No. 101,057.

Patented March 22, 1870.

Fig. 1.

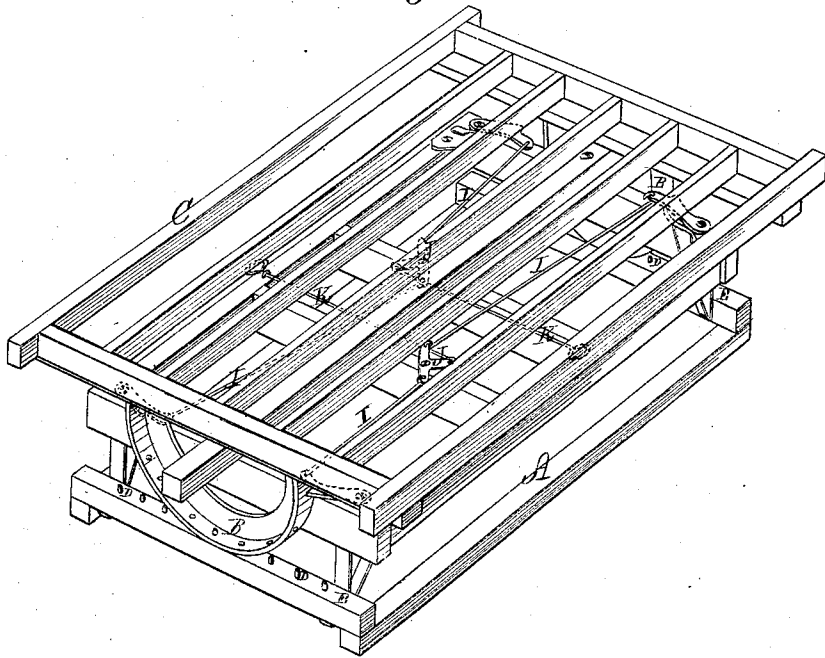
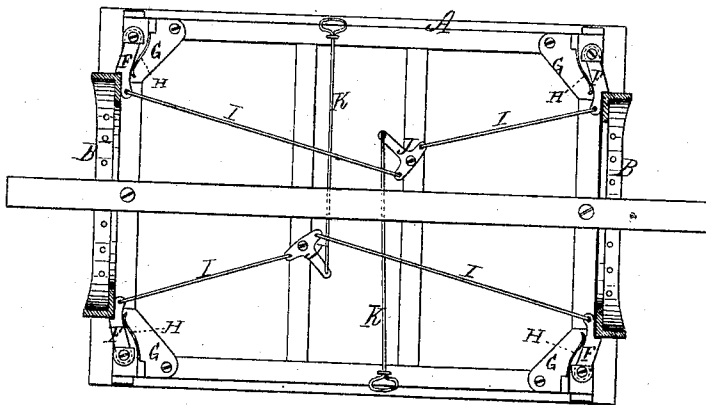

Fig. 2.



Witnesses:

Phil. A. Larnoy
Frank W. Jackson

Inventor:
Olmey S. Smith.
By *Wm. C. Wood*
Attorney.

United States Patent Office.

OLNEY L. SMITH, OF PROVIDENCE, RHODE ISLAND.

Letters Patent No. 101,057, dated March 22, 1870.

IMPROVEMENT IN DUMPING-CAR.

The Schedule referred to in these Letters Patent and making part of the same

To all whom it may concern:

Be it known that I, OLNEY L. SMITH, of the city and county of Providence and State of Rhode Island, have invented a new and useful Dumping-Car; and I do hereby declare the following to be a full, clear, and exact description thereof, sufficient to enable others skilled in the art to which my invention appertains to make and use the same, reference being had to the accompanying drawing forming part of this specification, and in which—

Figure 1 is a perspective view of one of my dumping-cars, and

Figure 2, a top view of the truck, with the platform removed, showing the arrangement of the locking mechanism.

Similar letters of reference indicate corresponding parts in both figures.

My invention consists in providing the truck of a dumping-car with a locking device, acting in connection with rockers supporting the platform of the car, whereby the same is securely held in an upright position when loaded, said locking device being constructed, arranged, and operating as hereafter described.

In the drawings—

A represents the truck.

B are rockers placed at each end of the frame, on which is mounted the platform C.

The bearing-surfaces of the rockers B are provided with openings made to fit pins, D, on rocker-plates, E.

The pins D are placed at equal distances apart on the plates, beginning at the center and extending toward each end, so as to admit of a sufficient tilting movement of the rockers B when dumping the contents of the car.

In fig. 2 I have shown the arrangement of the lock-

ing mechanism, together with the operating-devices, the platform of the car being removed.

F represents the latches, pivoted to plates G, placed at the corners of the truck-frame. The latches F are made with notched ends, which engage with the edges of the rockers B.

H are springs, which press against the ends of the latches F, for the purpose of holding them in position against the rockers.

I are rods connecting the latches F with double-acting bell-crank levers, J, pivoted to a cross-bar near the center of the truck-frame.

K represent handles attached to the levers J, and extending outward to the sides of the truck, so as to be within the reach of the operator.

The operation of my invention will be readily understood from the above description.

When it is desired to dump the contents of the car, the operator may stand upon one side, and, by drawing upon one of the handles K, the spring latches F are withdrawn from the rockers B, and the platform is then tilted. After this operation is finished the platform is drawn back, the latches F resuming their position against the rockers B, and the car is held in an upright position, ready to receive another load.

Having thus described my invention,

I claim as new and desire to secure by Letters Patent—

The combination of the rockers B and spring latches F, applied to the truck and body of a dumping-car, substantially as shown and described.

OLNEY L. SMITH.

Witnesses:

FRED. B. BYRAM,
EDWIN METCALF.