



(No Model.)

2 Sheets—Sheet 2.

G. E. HIBBARD.  
ROTARY ENGINE.

No. 282,520.

Patented Aug. 7, 1883.

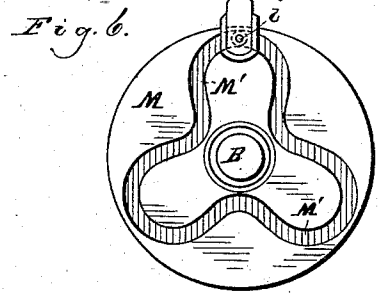
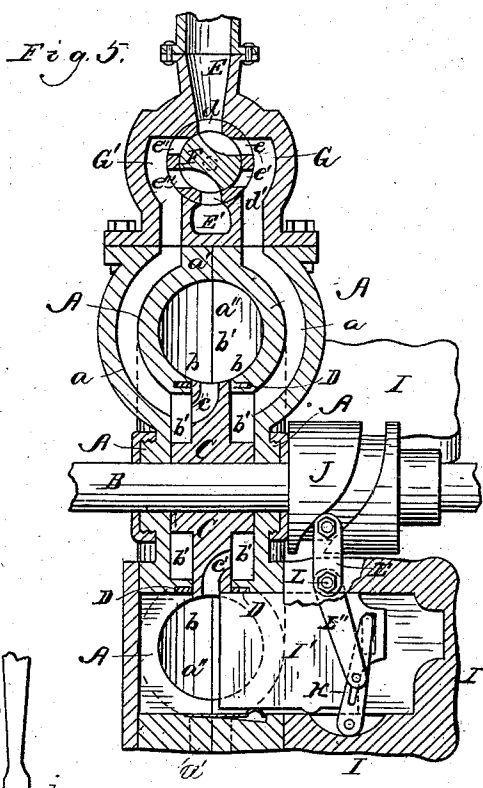
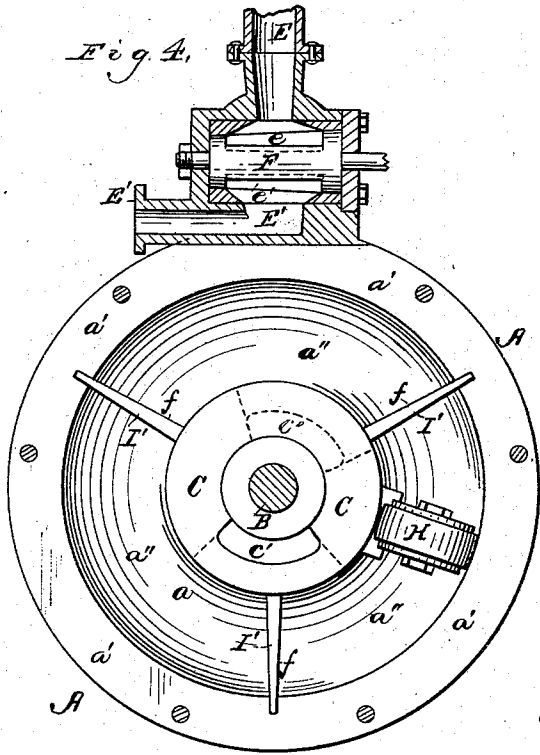

Witnesses,  
*Henry Frankfurter*  
*M. S. Baker*

Inventor,  
 George E. Hibbard  
 per. *Gridley & Co.*  
 his Attorneys.

# UNITED STATES PATENT OFFICE.

GEORGE E. HIBBARD, OF EVANSTON, ILLINOIS, ASSIGNOR OF ONE-HALF TO  
NELSON C. GRIDLEY, OF SAME PLACE.

## ROTARY ENGINE.

SPECIFICATION forming part of Letters Patent No. 282,520, dated August 7, 1883.

Application filed March 16, 1883. (No model.)

To all whom it may concern:

Be it known that I, GEORGE E. HIBBARD, of Evanston, in the county of Cook and State of Illinois, a citizen of the United States of America, have invented certain new and useful Improvements in Rotary Engines, of which the following, in connection with the accompanying drawings, is a specification.

In the drawings, Figure 1 is a side view of one side of a rotary steam-engine embodying my invention. Fig. 2 is an edge view of the same. Fig. 3 is a side view of the side opposite that shown in Fig. 1. Fig. 4 is a vertical section in the plane of the meeting edges of the cylinder-sections. Fig. 5 is a section in the plane of the line  $x x$ , and Fig. 6 is a face view of the cam for actuating the cut-off mechanism.

Like letters of reference indicate like parts. A represents the cylinder. This cylinder is made in two parts or sections,  $a a$ , each having circular perimeters, flanged, as shown at  $a' a'$ , for connection to each other by means of bolts and nuts or other suitable fastenings. The sections  $a a$  are concavo-convex between their central portions,  $b b$ , and the flanges  $a' a'$ , as shown, thus forming an inclosed or interior annular space or cylinder-chamber,  $a''$ ; but while the flanges  $a' a'$  are in junction with each other the parts  $b b$  do not meet, a space,  $b'$ , existing between them, which is filled in the manner hereinafter described.

B is a rotary shaft passing horizontally through the center of the cylinder A.

C is a hubbed circular flange or diaphragm rigidly attached to the shaft B and located in the space  $b'$ , dividing it into two annular chambers, as is clearly shown in Fig. 5. This flange terminates at the chamber  $a''$  and separates that chamber from the chamber in which the flange is located, excepting that the chamber on one side of the flange communicates with the chamber  $a''$  through a port,  $e$ , in the flange, and the chamber on the other side of the flange communicates with the chamber  $a''$  through a port,  $e'$ , also in the flange. These ports are separated from each other, as shown, and by a piston-head and sliding cylinder-heads, alternately, as hereinafter explained.

D D are packing-rings for packing the joint between the cylinder and the flange C.

D' D' are screws for holding the rings D D against the flange C.

E is the induction-port, and E' the exhaust.

F is a four-way valve located in a box or bushing, F', arranged between the ports E and E', and  $d d'$  are ports in the said box or bushing, one meeting the port E and the other the port E'; and  $e, e', e'',$  and  $e'''$  are ports, also in the said bushing, and located for being alternately opened and closed by the valve F, as will hereinafter be more fully explained. G and G' are steam channels or ducts, one of which is entered by the ports  $e$  and  $e'$  and enters the chamber  $b'$  on one side of the flange C, and the other of which has the like relation with the ports  $e''$  and  $e'''$  and the other side of the said flange. H is a piston in the chamber  $a''$  and rigidly fastened to the flange C.

I I are wings or pockets on one side of the cylinder A, and I' I' are sliding plates or cylinder-heads in the said pockets. These heads move entirely across the cylinder-chamber  $a''$ , which is slotted, as shown at  $f f$ , to permit such movement. These plates serve as cylinder-heads, one after the other, in the manner hereinafter more fully explained.

J is an external grooved cam rigidly applied to the shaft B.

K is a vibrating slotted arm pivoted at its lower end, and having at its upper end a lateral arm or finger extending into a slot in the plate I', so that the said plate will be reciprocated as the said arm is vibrated.

L is a crank-shaft or rocker having a rigid arm, L', the upper end of which carries a roller,  $g$ , Fig. 3, entering the groove of the cam J. The said shaft also has a rigid arm, L'', the lower end of which has a lateral finger entering the slot of the arm K. By this means, as the shaft B is rotated, the plates I' I' will be moved across and retracted from the chamber  $a''$ , one after the other in regular order, always moving in behind or back of the piston H and out in front of it, and at no time obstructing its movement. In the example shown there are three plates, I' I', arranged at about equal distances apart from each other. In function

they are equivalent to a cylinder-head; but as the piston H moves in an annular chamber and continuously in the same direction, while the position of the induction-valve is unchanged, the heads must be shifted out of the path of the piston as it approaches them and into its path as it leaves them; but one or the other is always in a position to serve as a cylinder-head. The location of the ports *c* and *c'* with respect to the plates I' I' contributes to this result, as will hereinafter more fully appear.

In connection with this engine I employ cut-off mechanism; but before describing that I will explain the operation of the parts now described, as they are operative by themselves independently of the cut-off mechanism, and as the description of the operation of the parts now described will aid in the understanding of the cut-off mechanism.

The steam, which enters through the port E, passes through the port *d*, and is deflected by the valve F through the port *e* and into the channel G, when the valve F is arranged as shown in Fig. 5. From the channel G the steam passes into that part of the chamber *b'* which is next thereto. Thence it passes through the port *c'* into the chamber *a''*, thence through the port *c* into the channel G', and out through the port *e'''* and the exhaust E'. When the steam enters the chamber *a''*, it finds the piston H therein, and also a cylinder-head I', extending wholly across the chamber *a''* and behind the piston; and the steam enters between these parts, the place of entrance always being behind the piston, as the piston is located between the ports *c* and *c'*, and is rigidly attached to the flange C, in which are the said ports. Consequently the piston is driven around in the chamber *a''*, the steam in front of the cylinder being discharged through the port *c*. This movement of the piston rotates the shaft B, and on the shaft the drive-wheel for conveying motion to other machinery is to be mounted. This rotation of the shaft, as before explained, throws in a plate or head I' behind the piston, as the latter advances, and draws out a plate or head in front of it, so that the steam is always live or active behind the piston and dead or exhausted in front of it. By this means the shaft B is rapidly and continuously moved. It should be remembered that the steam-port behind the piston is always in communication with the channels through which the steam enters, and that the port in front of the piston is always in communication with the induction-port E'. To reverse the engine, turn the valve F so as to close the port *e* and open the port *e'*, thereby also opening the port *e'''* and closing the port *e''*, and converting the induction-ducts into discharging-channels, and vice versa.

M is a rotary grooved cam rigidly attached to the shaft B, and M' is the groove in the said cam.

N is a link or lever, in which is a slot, *h*.

This link is fulcrumed on a stud or bearing, *h'*, projecting from the cylinder A, and in such a manner as not to close the slot *h*.

O is a pitman or connecting-arm jointed at its upper end to one end of the lever N, and provided on its lower end with a finger or roller, *i*, entering the groove M'. The central part of the arm O passes freely through a fixed guide, P.

Q is the reversing-lever, which is rigidly attached to the spindle *i'* of the valve F. The upper end of this lever is provided with a yielding bar or catch, *k*, engaging a serrated quadrant, *k'*.

Q' is the cut-off lever, which turns freely on the said spindle, and is provided on its upper end with a yielding catch, *l*, resting in a serrated quadrant, *l'*. The lower end of the lever Q' is slotted, as shown at *m*. Both of these levers pass up behind the quadrant *k'*, as indicated in Fig. 2.

R is a slotted link rigidly attached to the spindle *l'*, and R' is a slotted link depending freely from a pin, *n*, and pivoted or jointed at its lower end to the lever Q.

S is a pitman having on its upper end a lateral pin projecting through the links R and R', and on its lower end a like pin projecting through the slots *m* and *h*.

As the shaft B is rotated it rotates the cam M, and the arm O is thus moved up and down as it is engaged by the said cam or enters the groove M'. By this means the link or lever N is vibrated, and the pitman S is moved up and down and slightly vibrated as its lower pin passes through the slot *m*, which stands in an inclined position, as shown. The upper end of the pitman S vibrates the link R as the upper pin on this pitman passes through the slot in that link and through the slot in the link R', the latter of which is inclined and fixed so long as the catch *k* engages the quadrant *k'*, and the link R being rigid on the spindle *i*, the valve F is thus rocked and cuts off the steam to a greater or less extent. By shifting the position of the lever Q the extent to which the steam will be cut off may be varied, as the pitman S will have a longer or shorter stroke, according to the distance of its lower end from the fulcrum of the lever N; also, the link R will be more or less inclined, according to the position of the said levers. To reverse the engine, shift the positions of the levers Q and Q' with relation to each other. This shifting is permitted for the reason that the link R' is merely suspended from the pin *n*, and because the levers and links are slotted and arranged in the manner shown and described. By cutting off the steam I utilize the expansive force thereof after the cutting off, as in engines having a reciprocating piston working in connection with cut-off mechanism.

It will be perceived that very little packing is necessary, and that there is little friction. The principal features of my invention, however, are the automatically-shifting cylinder-

heads employed in connection with the cylinder, piston, and steam-ducts; but I intend also to claim many of the details shown and described, as will hereinafter appear.

5 Having thus described my invention, what I claim as new, and desire to secure by Letters Patent, is—

1. The combination, in a rotary engine, of the annular cylinder-chamber  $a''$ , the rotary flange or diaphragm C, carrying the piston H, and having in it the two ports  $c$  and  $c'$ , both entering the perimeter of the said flange and opening in opposite sides thereof, the space  $b'$  on each side of the said flange, and separated from the chamber  $a''$  by means of the said flange, excepting the communication of the said chamber and spaces with each other through the said ports, the three laterally-movable cylinder-heads I' I', arranged to move across the chamber  $a''$ , the induction and education ports and channels, and means for shifting the heads I' I' in and out of the chamber  $a''$ , for the purposes set forth.

2. The combination, in a rotary engine, of a rotary cam on the driving-shaft, the valve F, located in a box or bushing, F', having therein six ports, the induction-port E and the exhaust E', and cut-off arms, links, and levers operating in connection with the said cam and valve, substantially as and for the purposes set forth.

3. The combination, in a rotary engine, of the movable valve F and six-ported box or bushing F', in connection with induction and education ports, and means for shifting the position of the said valve with relation to the said ports, substantially as and for the purposes specified. 35

4. The combination, in a rotary engine, of the shaft B, the cam M, rigidly mounted on the said shaft, the movable valve F, the pitmen P and S, the levers H and Q, and the links R and R', substantially as and for the purposes specified. 40

5. The combination, in a rotary engine, of the shaft B, the cam M, rigidly mounted on the said shaft, the movable valve F, the pitmen P and S, the levers N and Q, and the links R and R', substantially as and for the purposes specified. 45

6. The combination, in a rotary engine, of the shaft B, the cam M, the valve F, the pitmen P and S, the levers N, Q, and Q', the links R and R', and means for temporarily locking the levers Q and Q', substantially as and for the purposes specified. 50 55

GEORGE E. HIBBARD.

Witnesses:

N. COWLES,  
W. S. BAKER.