



INTERNATIONAL APPLICATION PUBLISHED UNDER THE PATENT COOPERATION TREATY (PCT)

<p>(51) International Patent Classification ⁷ : G11B 7/12, 7/135</p>	<p>A1</p>	<p>(11) International Publication Number: WO 00/34949</p> <p>(43) International Publication Date: 15 June 2000 (15.06.00)</p>
<p>(21) International Application Number: PCT/EP99/09255</p> <p>(22) International Filing Date: 29 November 1999 (29.11.99)</p> <p>(30) Priority Data: 98204168.3 10 December 1998 (10.12.98) EP</p> <p>(71) Applicant: KONINKLIJKE PHILIPS ELECTRONICS N.V. [NL/NL]; Groenewoudseweg 1, NL-5621 BA Eindhoven (NL).</p> <p>(72) Inventors: HENDRIKS, Bernardus, H., W.; Prof. Holstlaan 6, NL-5656 AA Eindhoven (NL). BRAAT, Josephus, J., M.; Prof. Holstlaan 6, NL-5656 AA Eindhoven (NL).</p> <p>(74) Agent: VISSER, Derk; Internationaal Octrooibureau B.V., Prof. Holstlaan 6, NL-5656 AA Eindhoven (NL).</p>	<p>(81) Designated States: CN, JP, KR, European patent (AT, BE, CH, CY, DE, DK, ES, FI, FR, GB, GR, IE, IT, LU, MC, NL, PT, SE).</p> <p>Published <i>With international search report. Before the expiration of the time limit for amending the claims and to be republished in the event of the receipt of amendments.</i></p>	

(54) Title: DEVICE FOR OPTICALLY SCANNING A RECORD CARRIER

(57) Abstract

A device is described for optically scanning two types of record carrier (1; 25) with a radiation beam (15) having a high numerical aperture. The radiation beam is focused through a transparent layer (2; 26) of the record carrier on an information layer (3; 27) by means of an objective lens (10) and a plano-convex lens (11). The magnifying power of the plano-convex lens is equal to $1/n_1$, i.e. the inverse of the refractive index of the transparent layer (2). The gap between the plano-convex lens and the record carrier can be maintained at a fixed value when the scanning is changed between the first and the second record carrier.

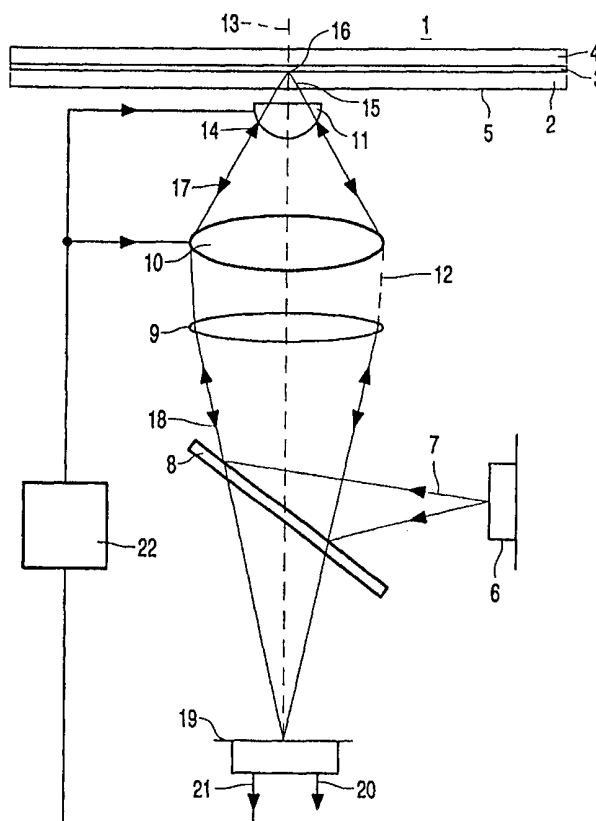

FOR THE PURPOSES OF INFORMATION ONLY

Codes used to identify States party to the PCT on the front pages of pamphlets publishing international applications under the PCT.

AL	Albania	ES	Spain	LS	Lesotho	SI	Slovenia
AM	Armenia	FI	Finland	LT	Lithuania	SK	Slovakia
AT	Austria	FR	France	LU	Luxembourg	SN	Senegal
AU	Australia	GA	Gabon	LV	Latvia	SZ	Swaziland
AZ	Azerbaijan	GB	United Kingdom	MC	Monaco	TD	Chad
BA	Bosnia and Herzegovina	GE	Georgia	MD	Republic of Moldova	TG	Togo
BB	Barbados	GH	Ghana	MG	Madagascar	TJ	Tajikistan
BE	Belgium	GN	Guinea	MK	The former Yugoslav Republic of Macedonia	TM	Turkmenistan
BF	Burkina Faso	GR	Greece	ML	Mali	TR	Turkey
BG	Bulgaria	HU	Hungary	MN	Mongolia	TT	Trinidad and Tobago
BJ	Benin	IE	Ireland	MR	Mauritania	UA	Ukraine
BR	Brazil	IL	Israel	MW	Malawi	UG	Uganda
BY	Belarus	IS	Iceland	MX	Mexico	US	United States of America
CA	Canada	IT	Italy	NE	Niger	UZ	Uzbekistan
CF	Central African Republic	JP	Japan	NL	Netherlands	VN	Viet Nam
CG	Congo	KE	Kenya	NO	Norway	YU	Yugoslavia
CH	Switzerland	KG	Kyrgyzstan	NZ	New Zealand	ZW	Zimbabwe
CI	Côte d'Ivoire	KP	Democratic People's Republic of Korea	PL	Poland		
CM	Cameroon	KR	Republic of Korea	PT	Portugal		
CN	China	KZ	Kazakstan	RO	Romania		
CU	Cuba	LC	Saint Lucia	RU	Russian Federation		
CZ	Czech Republic	LI	Liechtenstein	SD	Sudan		
DE	Germany	LK	Sri Lanka	SE	Sweden		
DK	Denmark	LR	Liberia	SG	Singapore		
EE	Estonia						

Device for optically scanning a record carrier.

The invention relates to an optical scanning device for optically scanning a first and second type of record carrier, the first type of record carrier comprising a first information layer and a first transparent layer having a first thickness, the second type of record carrier comprising a second information layer and a second transparent layer having a refractive index n_1 and a second thickness larger than the first thickness, the device comprising an objective lens and a convex lens for converging a radiation beam through the first or second transparent layer to a focus on the information layer, and means for axially positioning the convex lens, the convex lens having a convex surface facing the objective lens, a substantially planar surface facing the transparent layer, a magnifying power and a refractive index n_2 .

The amount of information that can be stored on an optical record carrier depends inter alia on the size of the radiation spot formed by the scanning device on the information layer of the record carrier. The information density and hence the amount of stored information can be increased by decreasing the size of the spot. The spot size can be reduced by increasing the numerical aperture of the radiation beam forming the spot. When using a single objective lens, such an increase of the numerical aperture is in general accompanied by a decrease of the free working distance of the lens forming the radiation beam, i.e. the smallest distance between the record carrier and the lens. At higher numerical apertures, the manufacturing costs of such objective lenses become high, the field of the lens reduces and the dispersion of the material the lens is made of gives increasing problems. The problems may be mitigated by inserting a convex lens between the objective lens and the record carrier. The convex lens may be plano-convex. The convex lens may be a slider lens or a solid immersion lens, and may be arranged at a very small distance above the record carrier by means determining its axial position, i.e. its position along the optical axis of the lens. Larger distances are also possible. The total convergence of the radiation beam is distributed over the objective lens and the plano-convex lens. An advantage of the use of the plano-convex lens is that it hardly adds aberrations to the radiation beam.

A scanning device having such a plano-convex lens is known from the European patent application no. 0 727 777. The device comprises an optical head in which an objective lens and a plano-convex lens converge a radiation beam to a numerical aperture

(NA) of 0.84 for scanning the record carrier through a transparent layer. The plano-convex lens is arranged at a small height above the record carrier. The lens may be mounted on a slider in sliding contact with the record carrier or floating on a thin air layer. The lens has a free working distance of several micrometers. It is a disadvantage of the known device, that, when the scanning is changed to a record carrier having a transparent layer with a greater thickness, the free working distance will reduce considerably. For some embodiment it appears to change from 300 to 125 μm when changing the thickness of the transparent layer from 100 to 600 μm . Such a reduction requires a height of the plano-convex lens that can be adjusted in dependence on the type of record carrier to be scanned. It also affects the dynamic behaviour of the plano-convex lens, in particular the behaviour of the servo controlling the axial position and/or the tilt of the lens and increases the risk of collisions between the optical head and the record carrier.

It is an object of the invention to provide a scanning device for scanning two types of record carrier with a high numerical aperture radiation beam that does not have the above disadvantages.

The object is achieved in accordance with the invention by a scanning device as described in the opening paragraph, which is characterized in that the magnifying power of the convex lens is substantially equal to $1/n_1$ and the means maintain the distance between the convex lens and the record carrier at a predetermined value. The scanning device has the advantage that the distance between the convex lens and the record carrier has substantially the same value for the first and second type of record carrier. Hence, the same suspension of the plano-convex lens can be used for both types of record carrier, thereby simplifying the design of the scanning device and improving the tolerance to crashes of the optical head of the scanning device into the record carrier. The servo system of the scanning device for axially positioning the objective lens and/or the convex lens can be relatively simple. The servo system must adjust the position of the objective lens such that the radiation beam is focused on an information layer and it must keep the distance between the convex lens and the record carrier at a constant value. The servo system does not required different settings for different record carriers. It is an advantage of the scanning device according to the invention, that spherical aberration compensation is automatically adjusted to the record carrier being scanned.

The magnifying power is preferably $1/n_1$ when scanning the type of record carrier requiring the largest numerical aperture (NA). This is, in general, the type of record carrier having the thinnest transparent layer. When the refractive index of the transparent layer

is in a range between 1.5 and 1.6, then the magnification is in a range between 0.625 and 0.667, i.e. 0.646 ± 0.021 .

The invention also relates to an optical scanning device for optically scanning a record carrier comprising at least two superjacent information layers and a transparent spacer layer having a refractive index n_1 arranged between the information layers, the device comprising an objective lens and a convex lens for converging a radiation beam to a focus on one of the information layers, and means for axially positioning the convex lens, the convex lens having a convex surface facing the objective lens, a substantially planar surface facing the transparent layer, a magnifying power and a refractive index n_2 , characterized in that the magnifying power of the convex lens is substantially equal to $1/n_1$, and the means maintain the distance between the convex lens and the record carrier at a predetermined value. When changing the scanning from one information layer to another one, the axial position of the objective lens must be changed to move the focus of the radiation beam to the desired information layer, whereas the distance between the convex lens and the entrance face of the record carrier, also called 'gap', need not be changed. Since the distance between the convex lens and the entrance surface of the record carrier can be kept at a fixed value, the construction of the optical head of the scanning device is simplified.

The refractive index n_1 of the transparent layer is preferably larger than the refractive index n_2 of the convex lens. The spherical aberration caused by the gap between the convex lens, having a refractive index lower than n_2 , and the transparent layer, having a refractive index larger than n_2 , at least partly compensate one another. The amount of spherical aberration to be introduced by the objective lens is then reduced, which in turn further increases the mentioned positional tolerance. The refractive indices are preferably related through $(n_1-1) > 1.03 (n_2-1)$.

To obtain a minimum spherical aberration at the location of the focus, the size of the gap, d_{gap} , depends preferably on the refractive index n_2 of the convex lens and n_1 of the transparent substrate according to the following relation:

$d_{\text{gap}}/d_s = (n_2/n_1^3) * (n_1^2 - n_2^2) / (n_2^2 - 1)$. The value of d_{gap} preferably complies with the relation within 40% for values of d_s larger than d_{gap} , where d_s is the thickness of the transparent layer.

The value of d_s is preferably larger than the value of d_{gap} in order to obtain refractive indices of available materials.

The product of the magnifying power and the refractive index n_1 lies preferably within a range from 0.95 to 1.05.

The objects, advantages and features of the invention will be apparent from the following more particular description of preferred embodiments of the invention, as illustrated in the accompanying drawings.

Figure 1 shows a scanning device;

Figure 2 shows an objective lens and a convex lens;

Figure 3 shows three different types of record carrier; and

Figure 4 shows an embodiment of an objective lens and a plano-convex lens.

Figure 1 shows a device for scanning an optical record carrier 1. The record carrier comprises a transparent layer 2, on one side of which an information layer 3 is arranged. The side of the information layer facing away from the transparent layer is protected from environmental influences by a protection layer 4. The side of the transparent layer facing the device is called the entrance face 5. The transparent layer 2 acts as a substrate for the record carrier by providing mechanical support for the information layer. Alternatively, the transparent layer may have the sole function of protecting the information layer, while the mechanical support is provided by a layer on the other side of the information layer, for instance by the protection layer 4 or by a further information layer and transparent layer connected to the information layer 3. Information may be stored in the information layer 3 of the record carrier in the form of optically detectable marks arranged in substantially parallel, concentric or spiral tracks, not indicated in the Figure. The marks may be in any optically readable form, e.g. in the form of pits, or areas with a reflection coefficient or a direction of magnetization different from their surroundings, or a combination of these forms.

The scanning device comprises a radiation source 6, for example a semiconductor laser, emitting a diverging radiation beam 7. A beam splitter 8, for example a semi-transparent plate, reflects the radiation towards a lens system. The lens system comprises a collimator lens 9, an objective lens 10 and a convex lens 11. The collimator lens 9 changes the diverging radiation beam 7 to a collimated beam 12. The objective lens 10, having an optical axis 13, transforms the collimated radiation beam 12 into a converging beam 14 incident on the lens 11. The collimator lens 9 and the objective lens 10 may be combined into a single lens. The convex lens 11 changes the incident beam 14 into a converging beam 15, which comes to a focus 16 on the information layer 3. The convex lens 11 has a convex surface and a substantially flat surface, i.e. the lens 11 is a plano-convex lens. The flat surface may have an aspheric profile without significant optical strength. The flat surface may have a curvature, e.g.

for aero-dynamic purposes, the curvature being sufficiently small not to affect significantly the optical performance of the convex lens. The flat surface faces the transparent layer 2 and forms a gap between the lens and the layer. Although the objective lens 10 is indicated in the Figure as a single lens element, it may comprise more elements, and may also comprise a hologram operating in transmission or reflection, or a grating for coupling radiation out of a waveguide carrying the radiation beam. Radiation of the converging beam 15 reflected by the information layer 3 forms a reflected beam 17, which returns on the optical path of the forward converging beam 14. The objective lens 10 and the collimator lens 9 transform the reflected beam 17 to a converging reflected beam 18, and the beam splitter 8 separates the forward and reflected beams by transmitting at least part of the reflected beam 18 towards a detection system 19. The detection system captures the radiation and converts it into one or more electrical signals. One of these signals is an information signal 20, the value of which represents the information read from the information layer 3. Another signal is a focus error signal 21, the value of which represents the axial difference in height between the focus 16 and the information layer 3. The focus error signal is used as input for a focus servo controller 22, which controls the axial position of the objective lens 10 and/or the convex lens 11, thereby controlling the axial position of the focus 16 such that it coincides substantially with the plane of the information layer 3. The part of the detection system, including one or more radiation-sensitive detection elements and an electronic circuit processing the output signal of the detection elements, used for generating the focus error is called the focus error detection system. The focus servo system for positioning the lens system comprises the focus error detection system, the focus servo controller and an actuator for moving the lens system.

The gap, i.e. the distance between the planar surface of lens 11 and the entrance surface 5 of the record carrier 1, should be maintained substantially at a nominal value, independent of the type of record carrier and of the position of the information layer in the record carrier. This can be attained by using a passive air bearing construction carrying lens 11 and designed to maintain the gap at its nominal value. It is also possible to use an optically derived error signal which represents the deviation of the actual gap from its nominal value; a special actuator then keeps the plano-convex lens at its prescribed distance from the transparent layer by using the error signal as an input signal for the actuator servo loop. The actuator of the lens 10 is controlled by the focus error signal 21 to keep the focus 16 on the information layer 3.

The spherical aberration which arises when the radiation beam has to be focused through a transparent layer which is thicker than the design thickness of the layer, is

compensated for by a focusing action of the objective lens. The focusing action causes the plano-convex lens to produce, due to the changing magnification, an amount of spherical aberration which cancels the aberration produced by the thicker transparent layer. During the focusing action of the objective lens, the gap should be maintained substantially at its nominal value in the above-mentioned way. The variations in the thickness of the transparent layer of a record carrier are in general of the order of a few percent of the nominal thickness, e.g. less than 10 μm for a nominal layer thickness of 100 μm . The variations for particular applications are within 3 μm p-p.

Figure 2 shows an enlargement of the objective lens 10 and the plano-convex lens 11. The objective lens 10 may be a mono-aspherical plano-convex lens or a bi-aspherical lens. The objective lens 10 is designed in a known way to compensate for the spherical aberration introduced by the convex lens 11 and the transparent layer 2, thereby making the radiation beam near the focus 16 nominally substantially free from spherical aberration.

The tolerance of the optical head for thickness variations of the transparent layer 2 can be relatively large if the magnifying power B of the plano-convex lens 11 is made substantially equal to $1/n_1$, i.e. the inverse of the refractive index of the transparent layer. This can be understood as follows. When the distance between lens 10 and lens 11 changes, the conjugate distances of lens 11 change. If the image conjugate of lens 11 changes by an amount of Δl , the spherical aberration W in the radiation beam 15 changes by

$$-\Delta W_1 = \frac{1}{8} (1 - B^2) NA^4 \Delta l$$

The spherical aberration introduced by a change Δd_1 in the thickness of the transparent layer 2 into the radiation beam 15 is equal to

$$\Delta W_2 = -\frac{1}{8} \frac{1}{n_1^3} (1 - n_1^2) \Delta d_1 NA^4$$

If the image conjugate of lens 11 changes by Δl and the thickness of the transparent layer by Δd_1 , then the distance d_2 between the lens 11 and the entrance face of the record carrier must change by Δd_2 to keep the focus of the radiation beam on the information layer, where

$$\Delta l = \Delta d_2 + \frac{\Delta d_1}{n_1}$$

The spherical aberration introduced by the thickness variation may be compensated by choosing $\Delta W_1 = -\Delta W_2$, resulting in a value of Δl equal to

$$\Delta l = -\frac{1}{n_1^3} \frac{(1-n_1^2)}{1-B^2} \Delta d_1$$

The resulting change Δd_{gap} in the distance d_{gap} between the flat surface of the plano-convex lens 11 and the entrance face 5 of the transparent layer 2 is

$$\Delta d_{\text{gap}} = -\frac{\Delta d_1}{n_1} + \Delta l = -\frac{\Delta d_1}{n_1} \left[1 + \frac{(1/n_1^2 - 1)}{1-B^2} \right]$$

- 5 The term between square brackets can be made zero by taking the value of B equal to $1/n_1$. In that case the change Δd_{gap} in the distance d_{gap} is in this approximation independent of the variations Δd_1 in the thickness of the transparent layer 2. In other words, the free working distance of lens 11 is independent of the thickness of the transparent layer.

The scanning device is designed for scanning two different types of record
 10 carrier. Figure 3 shows the first type of record carrier 25, comprising a transparent layer 26 having an entrance face 29 on which the radiation of the scanning device enters the record carrier. The record carrier 25 also comprises an information layer 27 and a protective layer 28. The second type of record carrier is the record carrier 1 shown in Figure 1, having the
 transparent layer 2, information layer 3 and protective layer 4. The information layers 3 and 27
 15 may have different or similar information densities and the information may be stored in different or similar types of marks in different or similar formats. The thickness of transparent layer 2 is larger than that of transparent layer 26. The thickness of the transparent layer 26 may be zero, making the record carrier a so-called air-incident record carrier 30, as shown in Figure
 3, and comprising an information layer 31 and a protective layer or substrate 32. In a particular
 20 example, the transparent layer 26 is a 100 μm thickness poly-carbonate foil and the transparent layer 2 is a 600 μm thickness polycarbonate layer, whereas the information density of the information layer 27 is higher than that of information layer 3. The gap between the convex lens 11 and the entrance surface 5 is chosen sufficiently small to realize the required high numerical aperture of the radiation beam 15 and sufficiently large to avoid crashes of the
 25 plano-convex lens 11 or its holder against the record carrier.

When the scanning is changed from a record carrier 25 of the first type to a
 record carrier 1 of the second type, the convex lens 11 is positioned at the same height above
 the entrance face 5 as it had above the entrance face 29. The axial position of the objective
 lens 10 is controlled by the focus servo system such that the focus 16 coincides with the
 30 information layer 27. The positioning of both lenses 10 and 11 will have changed the distance between them in such a way that the lenses compensate the change in spherical aberration

caused by the change in thickness of the transparent layer. Since the gap between the plano-convex lens 11 and the entrance face of both types of record carrier is substantially the same, the dynamic behaviour of the optical head will also be very similar for both types of record carrier.

5 Figure 4 shows an objective lens 45 and a convex lens 46 for the above scanning device. The wavelength of the radiation is 650 nm. The numerical aperture for scanning the record carrier 25 having a 100 μm polycarbonate transparent layer is equal to 0.85. The numerical aperture for scanning the record carrier 1 having a 600 μm polycarbonate transparent layer is equal to 0.60. The refractive index of polycarbonate at 650 nm wavelength is equal to 1.5806. The plano-convex lens 46 is made of the Schott glass FK3 with a refractive index of 1.46 and one flat surface. The radius of curvature of the convex surface of the lens 46 is 1.25 mm, and the thickness of the lens on the optical axis is equal to 1.25 mm. The value of n_1B for the lens 11 is 0.985. The distance between the plano surface 47 and the entrance face 29 of the record carrier 25 is designed to be 100 μm . When the scanning is changed to record carrier 1, the distance between the plano surface and the entrance face 5 changes to 93 μm to obtain optimum spherical aberration compensation, i.e. a change of only 7 μm on a distance of 100 μm . Hence, keeping the air gap equal to 100 μm will result in an effective spherical aberration compensation when changing from a record carrier of the first type to one of the second type.

20 The objective lens 45 is made of Schott glass LAKN22, having a refractive index of 1.648. The convex surface 48 of the objective lens has a radius of curvature r_1 equal to 2.429 mm, the concave surface 49 a radius of curvature r_2 equal to 180.368 mm. The thickness of the lens on the optical axis is 1.9 mm. The distance on the optical axis between the lenses 45 and 46 is 0.010 mm when scanning through the 600 μm transparent layer of record carrier 1 and 0.985 mm when scanning through the 100 μm transparent layer of record carrier 25. Both surfaces 48 and 49 have an aspheric profile, described by the following equation:

$$z = \frac{c_1 r^2}{1 + \sqrt{1 - (c_1 r)^2}} + a_2 r^2 + a_4 r^4 + a_6 r^6 + \dots$$

where $c_1 = 1/r_1$ for surface 48 and $c_1 = 1/r_2$ for surface 49, z is the coordinate along the optical axis and r is the radial coordinate perpendicular to the optical axis, as indicated in the figure. The values of the coefficients a_2 to a_{16} are as follows

Surface 48	Surface 49
$a_4 = -0.00064031138$	$a_4 = 0.018413388$
$a_6 = -0.002214109$	$a_6 = -0.023037169$
$a_8 = -0.00013925445$	$a_8 = 0.0171954$
$a_{10} = 0.00029925671$	$a_{10} = -0.0071408498$
$a_{12} = -0.00010404658$	$a_{12} = 0.0015024416$
$a_{14} = 1.2246551 \text{ e-5}$	$a_{14} = -0.00012458591$
$a_{16} = -5.0598072 \text{ e-7}$	$a_{16} = 0$

The scanning device is also eminently suitable for scanning a multi-layer record carrier 35 as shown in Figure 3. The record carrier comprises a transparent layer 36 with an entrance face 37, two information layers 38 and 39, separated by a transparent spacer layer 40, and a protective cover layer 41. The spacer layer may be a foil glued between the information layers or a UV-hardened spin-coated layer having a thickness of 30 μm . The material of the spacer layer may be a polymer such as poly-carbonate having a refractive index 1.58. When the scanning is changed from information layer 38 to information layer 39, the objective lens 10 is moved axially such that the focus 16 is displaced from information layer 38 to information layer 39. The distance between the plano-convex lens 11 and the entrance face 37 of the record carrier does not change, i.e. the free working distance stays approximately the same. The change in distance between the objective lens 10 and the plano-convex lens 11 introduces spherical aberration that compensates the spherical aberration due to the spacer layer 40. The combination of the objective lens and the plano-convex lens operates as an adjustable spherical aberration compensator.

CLAIMS:

1. An optical scanning device for optically scanning a first and second type of record carrier, the first type of record carrier comprising a first information layer and a first transparent layer having a first thickness, the second type of record carrier comprising a second information layer and a second transparent layer having a refractive index n_1 and a second thickness larger than the first thickness, the device comprising an objective lens and a convex lens for converging a radiation beam through the first or second transparent layer to a focus on the information layer, and means for axially positioning the convex lens, the convex lens having a convex surface facing the objective lens, a substantially planar surface facing the transparent layer, a magnifying power and a refractive index n_2 , characterized in that the magnifying power of the convex lens is substantially equal to $1/n_1$, and the means maintain the distance between the convex lens and the record carrier at a predetermined value.
2. Optical scanning device according to Claim 1, wherein the value of n_1 is larger than the value of n_2 .
3. Optical scanning device according to Claim 2, wherein the refractive indices n_1 and n_2 are related through $(n_1-1) > 1.03 (n_2-1)$.
4. An optical scanning device for optically scanning a record carrier comprising at least two superjacent information layers and a transparent spacer layer having a refractive index n_1 arranged between the information layers, the device comprising an objective lens and a convex lens for converging a radiation beam to a focus on one of the information layers, and means for axially positioning the convex lens, the convex lens having a convex surface facing the objective lens, a substantially planar surface facing the transparent layer, a magnifying power and a refractive index n_2 , characterized in that the magnifying power of the convex lens is substantially equal to $1/n_1$, and the means maintain the distance between the convex lens and the record carrier at a predetermined value.

5. Optical scanning device according to Claim 4, wherein the value of n_1 is larger than the value of n_2 .
6. Optical scanning device according to Claim 5, wherein the refractive indices n_1 and n_2 are related through $(n_1-1) > 1.03 (n_2-1)$.
- 5

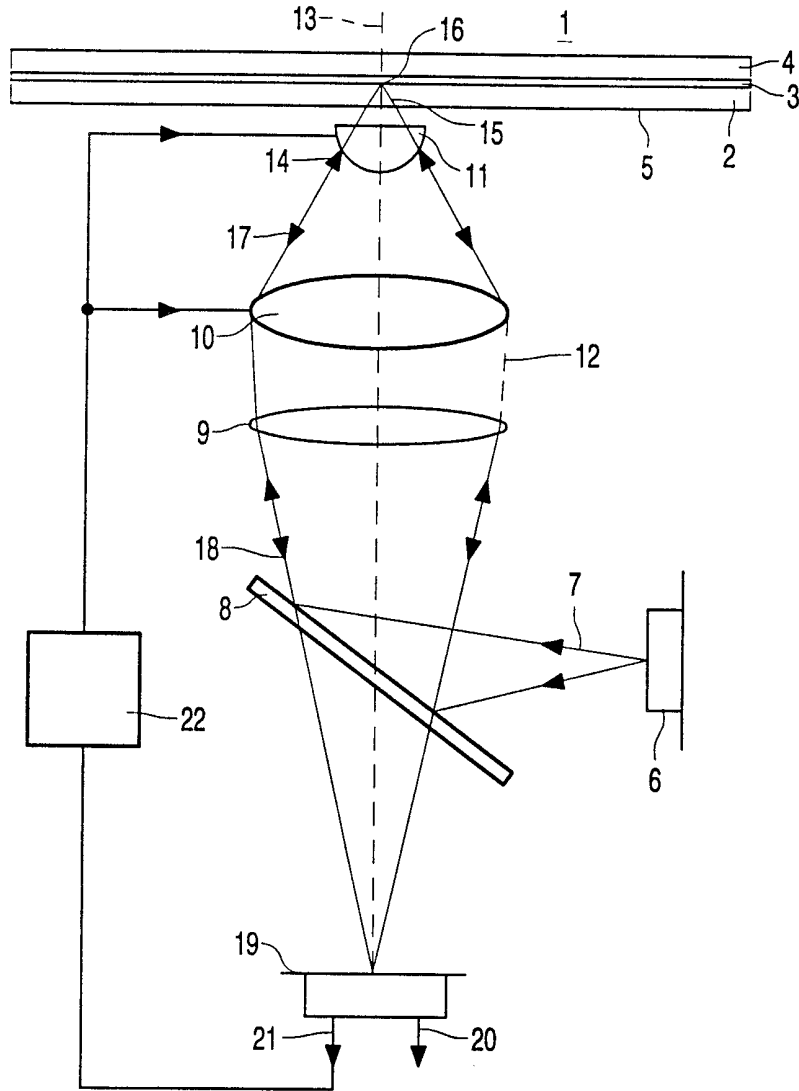

FIG. 1

2/2

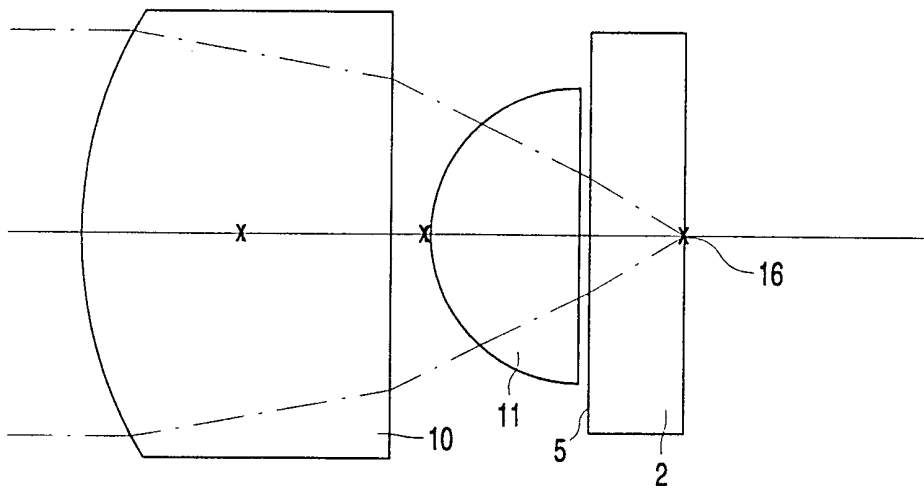

FIG. 2

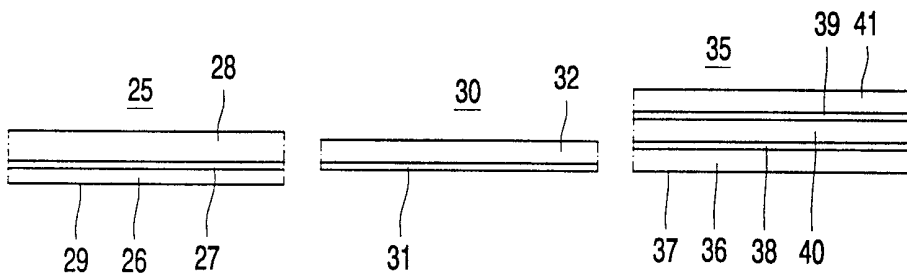

FIG. 3

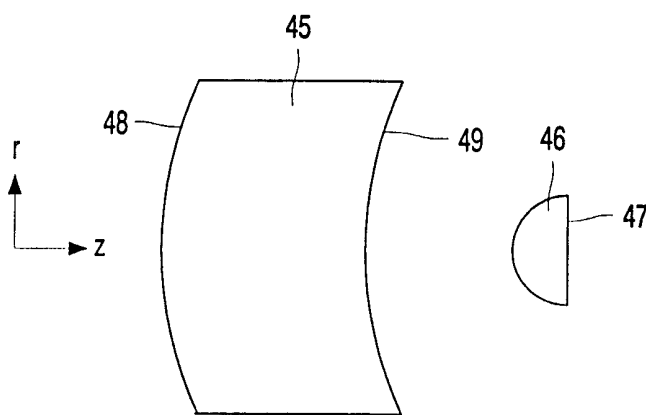

FIG. 4

INTERNATIONAL SEARCH REPORT

International Application No

PCT/EP 99/09255

A. CLASSIFICATION OF SUBJECT MATTER
 IPC 7 G11B7/12 G11B7/135

According to International Patent Classification (IPC) or to both national classification and IPC

B. FIELDS SEARCHED

Minimum documentation searched (classification system followed by classification symbols)
 IPC 7 G11B

Documentation searched other than minimum documentation to the extent that such documents are included in the fields searched

Electronic data base consulted during the international search (name of data base and, where practical, search terms used)

C. DOCUMENTS CONSIDERED TO BE RELEVANT

Category *	Citation of document, with indication, where appropriate, of the relevant passages	Relevant to claim No.
P, A	US 5 936 928 A (JAIN AMIT ET AL) 10 August 1999 (1999-08-10) abstract; figures 1,2 column 3, line 3 -column 5, line 40 ---	4-6
A	US 5 691 971 A (KIM JONG-RYULL) 25 November 1997 (1997-11-25) abstract; figure 2 column 2, line 37 -column 3, line 43 ---	4-6
P, A	EP 0 910 074 A (SONY CORP) 21 April 1999 (1999-04-21) abstract; figure 1 page 4, line 3 - line 46 ---	1-6
	-/--	

Further documents are listed in the continuation of box C.

Patent family members are listed in annex.

* Special categories of cited documents :

- *A* document defining the general state of the art which is not considered to be of particular relevance
- *E* earlier document but published on or after the international filing date
- *L* document which may throw doubts on priority claim(s) or which is cited to establish the publication date of another citation or other special reason (as specified)
- *O* document referring to an oral disclosure, use, exhibition or other means
- *P* document published prior to the international filing date but later than the priority date claimed

- *T* later document published after the international filing date or priority date and not in conflict with the application but cited to understand the principle or theory underlying the invention
- *X* document of particular relevance; the claimed invention cannot be considered novel or cannot be considered to involve an inventive step when the document is taken alone
- *Y* document of particular relevance; the claimed invention cannot be considered to involve an inventive step when the document is combined with one or more other such documents, such combination being obvious to a person skilled in the art.
- *&* document member of the same patent family

Date of the actual completion of the international search

7 April 2000

Date of mailing of the international search report

14/04/2000

Name and mailing address of the ISA

European Patent Office, P.B. 5818 Patentlaan 2
 NL - 2280 HV Rijswijk
 Tel. (+31-70) 340-2040, Tx. 31 651 epo nl,
 Fax: (+31-70) 340-3016

Authorized officer

Pariset, N

INTERNATIONAL SEARCH REPORT

International Application No

PCT/EP 99/09255

C.(Continuation) DOCUMENTS CONSIDERED TO BE RELEVANT

Category °	Citation of document, with indication, where appropriate, of the relevant passages	Relevant to claim No.
A	US 5 764 613 A (ICHIMURA ISAO ET AL) 9 June 1998 (1998-06-09) abstract; figures 1-4 column 6, line 41 -column 8, line 34 -----	1-6
P,A	DE 199 10 109 A (SHARP KK) 16 September 1999 (1999-09-16) abstract; figures 1-4 column 7, line 49 -column 15, line 6 -----	1-6
A	EP 0 727 777 A (SONY CORP) 21 August 1996 (1996-08-21) cited in the application abstract; figures 1-4 column 3, line 16 -column 5, line 20 -----	1-6

INTERNATIONAL SEARCH REPORT

Information on patent family members

International Application No

PCT/EP 99/09255

Patent document cited in search report	A	Publication date	Patent family member(s)	Publication date
US 5936928	A	10-08-1999	NONE	
US 5691971	A	25-11-1997	KR 147628 B	15-10-1998
EP 0910074	A	21-04-1999	JP 11120588 A CN 1220449 A	30-04-1999 23-06-1999
US 5764613	A	09-06-1998	JP 8315404 A	29-11-1996
DE 19910109	A	16-09-1999	JP 11259903 A	24-09-1999
EP 0727777	A	21-08-1996	JP 8221790 A CN 1135075 A SG 45208 A US 5774281 A US 5786947 A	30-08-1996 06-11-1996 16-01-1998 30-06-1998 28-07-1998