

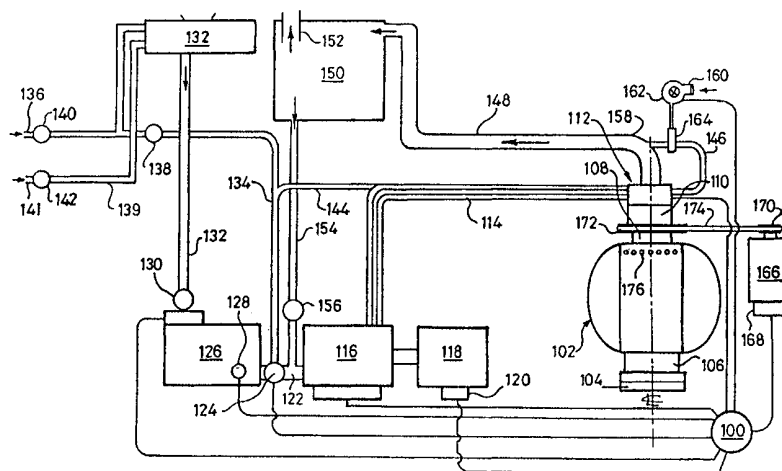

## INTERNATIONAL APPLICATION PUBLISHED UNDER THE PATENT COOPERATION TREATY (PCT)

<b>(51) International Patent Classification <sup>7</sup> :</b> <b>D06F 35/00, 43/00</b>	<b>A1</b>	<b>(11) International Publication Number:</b> <b>WO 00/58544</b> <b>(43) International Publication Date:</b> 5 October 2000 (05.10.00)
<b>(21) International Application Number:</b> PCT/GB00/01082 <b>(22) International Filing Date:</b> 23 March 2000 (23.03.00) <b>(30) Priority Data:</b> 9906800.9      25 March 1999 (25.03.99)      GB 9907304.1      31 March 1999 (31.03.99)      GB 9909836.0      29 April 1999 (29.04.99)      GB <b>(71)(72) Applicant and Inventor:</b> NORTH, John, Herbert [GB/GB]; 21 Briar Court, Guardian Road, Norwich NR5 8PR (GB). <b>(74) Agent:</b> KEITH W. NASH & CO.; 90-92 Regent Street, Cambridge CB2 1DP (GB).	<b>(81) Designated States:</b> AE, AG, AL, AM, AT, AU, AZ, BA, BB, BG, BR, BY, CA, CH, CN, CR, CU, CZ, DE, DK, DM, DZ, EE, ES, FI, GB, GD, GE, GH, GM, HR, HU, ID, IL, IN, IS, JP, KE, KG, KP, KR, KZ, LC, LK, LR, LS, LT, LU, LV, MA, MD, MG, MK, MN, MW, MX, NO, NZ, PL, PT, RO, RU, SD, SE, SG, SI, SK, SL, TJ, TM, TR, TT, TZ, UA, UG, US, UZ, VN, YU, ZA, ZW, ARIPO patent (GH, GM, KE, LS, MW, SD, SL, SZ, TZ, UG, ZW), Eurasian patent (AM, AZ, BY, KG, KZ, MD, RU, TJ, TM), European patent (AT, BE, CH, CY, DE, DK, ES, FI, FR, GB, GR, IE, IT, LU, MC, NL, PT, SE), OAPI patent (BF, BJ, CF, CG, CI, CM, GA, GN, GW, ML, MR, NE, SN, TD, TG).  <b>Published</b> <i>With international search report.</i>	

**(54) Title:** WASHING AND DRYING MACHINES AND DRY-CLEANING MACHINES



**(57) Abstract**

A machine for washing and/or cleaning articles comprises a sealable enclosure for containing the articles to which cleaning liquid is to be supplied. The cleaning liquid is heated to a high temperature and forced into the enclosure under high pressure as finely dispersed or diffused droplets forming a mist or vapour. A pressure greater than atmospheric is maintained in the enclosure to force the cleaning liquid into at least the surface if not through and into the very structure of the material from which the articles are formed, so as to assist the cleaning process by producing a quicker and more efficient saturation of the articles by the cleaning liquid. The latter may comprise water and detergent or a dry-cleaning solvent. The cleaning liquid is removed from the articles and the interior of the enclosure by means of a suction pump. If a rinse is required, it is replaced by clean liquid for rinsing, preferably also at higher than atmospheric pressure and if desired also heated to higher than ambient temperatures. The rinsing liquid is also removed from the enclosure by suction. The suction is obtained by a suction pump typically a venturi vacuum pump and this is also employed to create a partial vacuum in the enclosure during a drying phase after the cleaning and, if desired rinsing stages.

*FOR THE PURPOSES OF INFORMATION ONLY*

Codes used to identify States party to the PCT on the front pages of pamphlets publishing international applications under the PCT.

AL	Albania	ES	Spain	LS	Lesotho	SI	Slovenia
AM	Armenia	FI	Finland	LT	Lithuania	SK	Slovakia
AT	Austria	FR	France	LU	Luxembourg	SN	Senegal
AU	Australia	GA	Gabon	LV	Latvia	SZ	Swaziland
AZ	Azerbaijan	GB	United Kingdom	MC	Monaco	TD	Chad
BA	Bosnia and Herzegovina	GE	Georgia	MD	Republic of Moldova	TG	Togo
BB	Barbados	GH	Ghana	MG	Madagascar	TJ	Tajikistan
BE	Belgium	GN	Guinea	MK	The former Yugoslav Republic of Macedonia	TM	Turkmenistan
BF	Burkina Faso	GR	Greece	ML	Mali	TR	Turkey
BG	Bulgaria	HU	Hungary	MN	Mongolia	TT	Trinidad and Tobago
BJ	Benin	IE	Ireland	MR	Mauritania	UA	Ukraine
BR	Brazil	IL	Israel	MW	Malawi	UG	Uganda
BY	Belarus	IS	Iceland	MX	Mexico	US	United States of America
CA	Canada	IT	Italy	NE	Niger	UZ	Uzbekistan
CF	Central African Republic	JP	Japan	NL	Netherlands	VN	Viet Nam
CG	Congo	KE	Kenya	NO	Norway	YU	Yugoslavia
CH	Switzerland	KG	Kyrgyzstan	NZ	New Zealand	ZW	Zimbabwe
CI	Côte d'Ivoire	KP	Democratic People's Republic of Korea	PL	Poland		
CM	Cameroon	KR	Republic of Korea	PT	Portugal		
CN	China	KZ	Kazakstan	RO	Romania		
CU	Cuba	LC	Saint Lucia	RU	Russian Federation		
CZ	Czech Republic	LI	Liechtenstein	SD	Sudan		
DE	Germany	LK	Sri Lanka	SE	Sweden		
DK	Denmark	LR	Liberia	SG	Singapore		
EE	Estonia						

Title: Washing and drying machines and dry-cleaning machines.

Field of invention

This invention concerns machines for washing and drying articles such as clothes, bed-linen, curtains, towels and the like and machines by which such articles can be dry-cleaned. Articles which can be so washed/dried and/or dry-cleaned are hereinafter simply referred to as articles.

Background to the invention.

Existing machines tend to comprise a rotary drum mounted within a housing. Access to the drum for loading and unloading articles to be washed/cleaned is via a top opening lid or front opening door.

Water and detergent is pumped into the drum and the latter is rotated so as to agitate the articles and thoroughly saturate articles with the detergent solution. The articles are then rinsed using clean water and finally are dried by spinning the drum at high speed so as to force moisture out of the articles under centrifugal force and by blowing heated air through the articles in the drum as the latter is rotated more slowly.

In a similar way dry-cleaning is achieved by introducing an appropriate volatile solvent into the drum and rotating the latter whilst in closed condition so as to saturate the articles with the solvent. The spin drying step is not normally called for and the solvent is removed from the articles by blowing hot air through the drum. By virtue of the odour and possibly harmful effects of breathing in the solvent vapour, the latter is normally separated from the exiting valour laden air, and collected before the air is released from the machine.

In the case of a washing machine the process tends to use large quantities of water and energy and a typical washing and drying cycle can be as long as 120 to 250 minutes.

It is an object of the present invention to provide apparatus that can be used for washing and drying articles in a shorter time-scale and with reduced energy requirements and which can be used with minor modification for dry-cleaning articles using an appropriate dry-cleaning solvent.

The detergent solution or the dry-cleaning solvent used to saturate the articles to wash or dissolve away dirt, will hereinafter simply be referred to as the cleaning liquid.

#### Summary of the invention

According to one aspect of the present invention in a machine for washing and/or cleaning articles and which comprises a sealable enclosure for containing the articles to which cleaning liquid is to be supplied, the cleaning liquid is heated to a high temperature and forced into the enclosure under high pressure as finely dispersed or diffused droplets forming a mist or vapour so that a pressure greater than atmospheric is maintained in the enclosure to force the cleaning liquid into at least the surface if not through and into the very structure of the material from which the articles are formed, so as to assist the cleaning process by producing a quicker and more efficient saturation of the articles by the cleaning liquid.

According to another aspect of the invention cleaning liquid is removed from the articles and the interior of the enclosure by means of a suction pump and replaced by clean liquid for rinsing, preferably also at higher than atmospheric pressure and if desired also heated to higher than ambient temperatures.

By supplying rinsing liquid at higher than atmospheric pressure and preferably in the form of a mist or vapour, so the rinsing liquid will also be forced into at least the surface if not into the very structure of the material from which the articles are made.

According to another aspect of the invention the rinsing liquid may also be removed from the enclosure by suction.

According to a further aspect of the invention, during a drying cycle following a rinsing cycle suction is employed to reduce the pressure on the downstream side of the enclosure substantially below atmospheric, so that evaporative drying of liquid remaining on or in the material from which the articles are formed, occurs, and vapour laden air produced by the evaporation is removed from the enclosure by the scavenging action of the air being drawn from the enclosure under the suction.

It has been found that a suction assisted drying cycle can dry articles to a satisfactory level of dryness, without the need for the application of heat. This substantially reduces the energy requirement of the drying cycle.

It has also been found that a suction assisted drying cycle can dry articles to a satisfactory level of dryness without the need to centrifugally remove the moisture from the wet articles by spin-drying. This again saves the energy that would otherwise be needed to rotate the enclosure at high speed to achieve centrifugal drying and can also reduce the size ie power of the drive motor for the enclosure since it is no longer required to rotate the enclosure at high spin speeds.

It has also been found that the liquid saturating stage of a washing or dry-cleaning cycle can also be performed without the addition of substantial quantities of heat. Where this is the case the energy otherwise needed to heat the enclosure and articles and liquid on and/or in the articles, is no longer required.

Even where heat is required to raise the temperature of the enclosure, articles and cleaning liquid, the pressurised article saturation process is so much more efficient at permeating the articles and releasing dirt particles than when carried out at atmospheric pressure, that the volume of liquid to be heated tends to be less, and/or the time during which the heat

has to be applied is much shorter, than in a conventional process, and again significant energy saving can be achieved.

The enclosure may comprise a rotatable drum, with a drive means for rotating the drum when in use and inlet and outlet means permitting relative movement to enable liquid and air to be supplied to and drawn off therefrom whilst the drum is rotating.

Alternatively the enclosure may comprise a housing within which a rotatable drum is mounted and liquid and air can be forced into and out of the drum axially and/or radially through openings, typically a large number of small apertures such as perforations in the wall of the drum, and in one embodiment the air and liquid mixture may be forced into the drum in a radial sense from the space around the drum within the housing, and be collected and conveyed away from the drum via a central porous or apertured hollow sleeve, mounted axially and centrally within the drum.

The housing may form part of the drum and rotate therewith, or be stationary so as to simplify the air and liquid supply to, and drainage from, the drum.

The invention is of particular application to domestic as well as commercial and industrial washing machines.

The invention also lies in apparatus for performing the various aspects of the invention.

Since the apparatus remains little changed for allowing a dry-cleaning process to take place, the invention also provides apparatus that can be used for washing and drying, or dry-cleaning, articles.

In apparatus as aforesaid the above atmospheric air pressure is preferably obtained using an impeller or turbine or more preferably a centrifugal air pump, and the suction to produce depressed pressures below atmospheric is preferably obtained using a venturi vacuum pump.

A preferred venturi pump is a dual conical venturi jet high vacuum pump capable of generating a suction equivalent to 760mm Hg. However it is to be understood that the invention is not restricted to the use of any particular type of pump.

Preferably a filter or the like is provided at the inlet to the enclosure and liquid is finely dispersed and/or diffused on entry into the enclosure by forcing it therethrough.

The liquid may to advantage be mixed with air both at elevated pressure and if desired elevated temperature before being forced under pressure, or by suction due to vacuum, through the inlet filter.

The filter may be a fine mesh filter.

In a preferred embodiment the enclosure is in the form of an elliptical capsule mounted for rotation about an axis through the mid-point of the longer axis perpendicular to the latter and comprising a diameter of the cylindrical mid-region of the capsule so that articles located therein will tend to fall from one end to the other as the capsule is rotated and thereby assist in the mixing of the liquids introduced into the capsule during the washing or cleaning process and to agitate the articles excessively during the drying cycle to further assist in removing moisture therefrom.

Where the capsule is to be loaded and unloaded through a circular opening in the front wall of a rectangular housing within which the capsule is located for rotation, and wherein the opening in the front housing wall is normally closed by a hinged circular door, the front opening (and in consequence the door also), is preferably arranged coaxially relative to the axis of rotation of the capsule, and the capsule includes a circular opening which aligns with the circular front housing opening, and an annular seal is provided between the two openings to enable a positive pressure to be maintained in the capsule after the door has been closed.

Preferably a double door assembly is provided one closing an opening in the capsule wall and the other the opening in the front wall of the housing.

Preferably a seal is provided around each said door to seal it against the opening in the capsule wall, or the opening in the front housing wall, respectively.

Valve means is preferably provided to control the admission of liquid and air to the capsule after the openings have been sealingly closed.

Typically the valve means comprise solenoid valves.

The capsule is typically mounted for rotation by two rotary support bearing assemblies, one surrounding the loading and unloading opening and the other attached to a diametrically opposite region of the cylindrical wall of the mid-region of the capsule coaxial with the first bearing assembly.

The second bearing assembly surrounds a circular region in the capsule wall opposite to the loading and unloading opening, and concentric pipe means having a rotary seal with the wall of the capsule, enables the capsule to rotate whilst still being connected to the liquid and air supplies and also allows liquid and air to enter the capsule whilst the latter rotates.

The pipe means may communicate with one or more fine mesh filters to disperse and diffuse the incoming high pressure liquid and air into a fine mist.

In a preferred embodiment the valve means controlling the passage of liquid and air into the capsule may be arranged adjacent the pipe means where it extends through the capsule wall and may be attached to or form part of the capsule wall.

The pipe means and valve may be surrounded by and extend axially through a hollow cylindrical drive shaft carrying a large diameter pulley which shaft extends through a

support bearing assembly at the rear of the capsule and is joined to the capsule wall. A motor, typically an electric motor, whose output shaft carries a complementary pulley aligned with the first mentioned pulley, allows drive to be transmitted to the drive shaft from the motor via a drive band, to rotate the capsule about the support bearing axis.

The bearing assembly may be a solid ring or a so-called split bearing, and is mounted on a sub-frame within the housing.

In one arrangement the opposite ends of the capsule include sieve-type filters and the pipe means deliver liquid and air to the two filters to enter the interior of the capsule from opposite ends thereof.

In another arrangement a hollow cylindrical sleeve extends across the interior of the capsule coaxial with the aligned support bearing axes which define the axis of rotation of the capsule and the sleeve wall is perforated with tiny apertures through which the liquid and air exit into the interior of the capsule as a fine mist diffused by the tiny perforations which form a cylindrical fine mesh sieve type filter.

The fine mesh filter allows the incoming pressurised liquid and air to diffuse into the articles and produce a fast gaseous reaction inside the capsule due the liquid gaining heat energy by virtue of the liquid being forced through the plurality of tiny openings making up the filter mesh. It has been observed that this gives a sprinkler jet action for the gas-liquid mixture and yields excellent gaseous state cleaning particularly in the case of a washing machine where the liquid is water mixed with detergent.

A particularly preferred arrangement in the case of a washing machine involves a heater to heat the water to boiling point so that at least part of the liquid entering the capsule is in the form of steam vapour.

The preferred shape of the capsule ensures that articles and liquid are tumbled from one end to the other under gravity as the capsule is rotated.

If it can be arranged that the air expands due to its being heated after coming into contact with the steam, a further increase in pressure within the capsule will result causing the detergent suds to more thoroughly permeate the articles particularly where the latter are formed from woven fabric, so further assisting the release of dirt and particles causing stains and marks in the fabric.

In the case of a washing machine for washing garments and other fabric articles, the strong suction coanda effect gathers the garments around the central sleeve.

In the case of a top loading machine it has been found preferable to extract the liquid and air from the end of the capsule opposite to the end containing the sealable opening through which access can be gained to the interior of the capsule, so that the garments tend to gravitate towards the end opposite to the opening under the suction effect, and in this way the weight of the garments at that end will tend to ensure that the capsule will always come to rest with its end containing the access aperture uppermost and in alignment with an opening in the housing surrounding the capsule which in use will normally be closed by a lid.

The vacuum induced suction within the capsule not only produces a fast dehydration of the moist articles within its interior, so enhancing the drying process and doing so without the application of heat energy, but also particles and fibres are all sucked out of the capsule and there is no need for filters, screens or strainers in the outlet which in a conventional washing machine regularly have to be cleaned out.

The invention has permitted the drying time for a specimen 5Kg load to be reduced from 120 minutes in a conventional washer-drier operating in tumble-dry mode to between 1 and 2 minutes.

In a preferred embodiment of the invention in the form of a washing machine, the venturi suction pump creates a pressure drop equivalent to 760mm Hg., a pump supplies water to

the venturi at between 150 and 300 psi (the latter for industrial applications and the former for domestic applications), and optimum operation is obtained when the ambient pressure is 14.72 psi., since it has been found that an increase in pressure can result in cavitation within the flow which reduces the suction from typically 760mm to 300mm Hg.

The pump may be a centrifugal or positive displacement pump.

A three port conduit high vacuum venturi pump is preferred.

In a preferred vacuum pump the venturi tube includes peripheral air duct set around the outside of the venturi outlet and this arrangement accelerates with flow. The venturi tube is connected to a branch inlet at the mid point of a 90 degree radius bend radius relative to the centreline of the tube o/d to provide a strong vacuum suction. The centrifugal pump delivers water through the venturi supply tube and a centrifugal air blower outlet is connected via a pipe to the peripheral air chamber to control the air flow around the venturi, which in turn controls the amount of the suction.

Preferably an air pressure relief valve is provided which also controls the amount of suction created.

Preferably the vacuum the temperature and the pressure are displayed in an analogue or digital display (preferably an analogue LCD bar display) on the front of the machine housing.

The user is then able to see which of the programmes has been reached and to control conditions as required in addition to operating the conventional washing machine controls.

Advantages of a washing machine embodying the invention are inter alia:

1. Smaller electric motor and lower drive speeds for the drum capsule, so less wear and tear on the machine bearings and shock absorbing mountings.

2. Low water consumption relative to a conventional washing machine process eg 23 litres for a 5½Kg load.
3. Variable temperature short duration wash, rinse and drying cycles. Washing has been accomplished in 3 to 5 minutes, rinse cycle time has been as low as 1 minute and vacuum assisted drying has been down to 1 to 2 minutes. A high pressure crease guard rinse cycle can be automatically incorporated.
4. Gentle rotation means less wear on fabrics.
5. No heat drying allows very delicate temperature sensitive fabrics to be handled.
6. A machine embodying the invention can give a superior wash and dry to the present class A wash and dry specification irrespective of load weight.
7. The efficient permeation under pressure of fabrics by the liquids during washing and the vacuum assisted drying without the need for heat saves water , electricity and detergent.
8. The lack of heating garments during drying results in less likelihood of wear and tear and shrinkage.
9. Low electrical energy consumption.400 washes per year using current washing machine technology would use 2216kWh per year which at £.07 per kWh means a cost of £156.The present invention would allow 400 similar wash cycles using a washing machine embodying the present invention would use in the range of 130 to 208 kWh per year at a cost of between £9 and £14.60, giving a saving of 96% in energy costs.
10. Minimal vibration and light weight due to the absence of heavy balancing masses.

The invention provides novel and advantageous combinations of features as follows:

- A. A method is claimed for the use of a capsule type washing drum (of any shape) with a pressurised door. with the axis of the capsule perpendicular to the axis of rotation, which is midway along the capsule.
- B. A method as claimed for the use of one or two end sieve type filters, with vacuum ducts or an internal central filter with fine holes or sieve type mesh filter screen to increase the acceleration and the gaseous content of the gas and liquid mixture as it enters the capsule. The single end filter inside the capsule, enables the capsule drum, top loader always to stop in the vertical upright plane, and the central filter will also stop the capsule in the horizontal plane.
- C. A method is claimed for the use of a transparent dual rotating inner door connected to a stationary outer door, connected to a central member, for sealing against the cylindrical inner seal that is set inside the laundry loading aperture of the axial drive shaft of the capsule washing drum.
- D. A method is claimed for the use of a venturi type vacuum pump in a washing or drying machine. For emptying the washing liquid, rinsing water and for removing water and moisture from the garments.
- E. A method is claimed for the use of an air pump to control suction strength in conjunction with a venturi type jet pump. This provides for some moisture to remain within the garments, if so required.
- F. A method is claimed for the use of a mechanical/rotary driven capsule type washing drum, front loading or top loading, with or without a vacuum drying system.
- G. A method is claimed for the use of a capsule type drum as disclosed within the Patent for the use as a dry cleaning unit.

- H. A method is claimed for the use of a rotary swivel drive joint, with a delivery and discharge solenoid operated multi port valve (not shown) for use with a pressure capsule washing drum machine.
- I. A method is claimed for the use of a drive belt or gearing to rotate the capsule washing drum.
- J. A method is claimed for the use of a LCD or similar bright bar type displays as disclosed within the Patent.
- K. A method is claimed for the use of a separate heater tank as disclosed within the Patent or a combined inner and outer shell capsule as the heater tank.
- L. A method is claimed for the use a single lower sieve type filter screen and an internal type conduit to draw the vacuum within a top loading capsule washing drum, the garments inside would always drop to the bottom of the capsule by gravity, due to suction the moment the vacuum cycle starts, this will always place the loading aperture to the top of the machine, in the vertical upright plane.
- M. A method is claimed for the use of any type of sealing arrangement which can be used to provide a pressure seal between the inner rotating transparent glass door and the capsule washing drum as disclosed within the Patent.

Fluid flow in the various flow and return lines is preferably controlled via solenoid outlet valves.

Functions are preferably controlled by a programmable control unit such as a programmable line computer (PLC).

A typical washing and rinsing cycle comprising the following steps:

1. Load powder or liquid detergent.
2. Load capsule with articles to be washed (the wash load).
3. Supply cold and hot water typically a gravity feed to a heating tank via solenoid valve means, where it is mixed with a detergent.
4. Heat the mixture to the required temperature (typically of the order of 40, 50, 60 or 90 degrees centigrade).
5. Pump the heated mixture into the capsule through a rotary joint assembly and through an internal fine filter, causing diffusion of the liquid for a fast gaseous reaction inside the capsule. The solution becomes heated as it is forced through the apertures in the filter resulting in a sprinkler jet action.
6. In conjunction with step 5, the capsule is rotated at approximately 80rpm except during the emptying of the wash and rinse/drying cycles.
7. At the end of the washing cycle all the washing fluid is sucked from the capsule by a venturi pump.
8. After the rinse cycle starts, cold water under the supply pressure is supplied to the capsule from the cold water supply. Typically this entails supplying cold water from the mixing compartment.
9. At the end of the rinse cycle, spend rinse water is removed by suction using the venturi pump.

Typically using the invention to wash a load weighing approximately 5.5kgs requires 7.5 litres of water and 6 tablespoons of low foaming powder or liquid detergent.

According to another aspect of the present invention, the capsule may be used for dry cleaning by introducing a volatile cleaning fluid such as isopropyl alcohol into the capsule with one or more items of clothing or the like which are to be dry cleaned, sealing the capsule so as to provide a gas-tight compartment, rotating the capsule in the range 80-100rpm and prior to unsealing the capsule to remove the clothing or like articles, extracting vapours and gases left over from the cleaning process by operating the suction pump.

The invention will now be described by way of example, with reference to the accompanying drawings, in which:

Figure 1 shows a side elevation view partially in section of a capsule washing drum front loading machine;

Figure 2 shows a top longitudinal elevation view partially in section of a capsule washing drum;

Figure 3 shows a radial elevation of a capsule washing drum, through the central section A-A of the internal sleeve fine suction filter;

Figure 4 shows a front elevation partially in section of a capsule washing drum machine;

Figure 5 shows a schematic sectional view of a rotary swivel joint connected to the vacuum venturi pump;

Figure 6 shows a diagrammatic view partially in section of a venturi vacuum jet pump;

Figure 7 shows a schematic of a centrifugal pump for suction control;

Figure 8 shows a side elevation view partially in section of a capsule washing drum top loading machine;

Figure 9 shows a diagrammatic view of a pressure/vacuum capsule washing drum machine with controls;

Figure 10 shows a diagrammatic view of a front display panel;

Figure 11 shows a top elevation cross-section view of a glass transparent pressure/vacuum rotational sealing inner plug door and stationary transparent outer door;

Figure 12 shows an axial cross-section of a compression spring;

Figure 12A shows a radial cross-section of Figure 12;

Figure 13 shows a bearing circlip;

Figure 14 shows two sets of split bearing shells;

Figure 15 shows a radial section of a backing ring;

Figure 15A shows an axial section of the opposite backing ring;

Figure 16 shows an axial section of a thrust ring;

Figure 17 shows a top longitudinal elevation view of a capsule washing drum;

Figure 18 shows a radial cross-section of a capsule washing drum.

Figure 1 is a side elevation view partially in section of a capsule washing drum machine and illustrates the disclosed preferred embodiment of the apparatus assembled in accordance with the present invention for washing and drying garments. Showing outer cabinet shell Item 9, adjustable levelling feet Item 10, capsule washing drum Item 1, dual rotary transparent glass door Item 2, bearing block retaining axial drive shafts Item 3, and 24, support frame for capsule drive shafts item 4, and 17, water and detergent supply tube to heater tank item 5, water heater Item 16, controls item 6, detergent drawer Item 7, water supply to drawer Item 8, suction inlet to pump for heater tank Item 11, electric motor Item 12, drives water-detergent pump Item 13, water-detergent supply tube item 15, 26, and 20, to control valve and drain outlet Item 25, for supply to the capsule washing drum through the solenoid valve-rotary swivel joint Item 23, vacuum tube Item 27, venturi tube Item 28, air supply tube Item 29, centrifugal air motor/pump Item 30, air inlet to

pump item 31, electric drive motor and reduction gearing Item 14, motor drive pulley Item 21, capsule washing drum drive pulley Item 32, drive belt Item 22, hot water in Item 19, cold water in Item 18.

Figure 2 discloses a top longitudinal elevation view partially in section of a capsule washing drum showing axial drive shaft side Item 1, loading side Item 3, supply and suction ports Item 3, washing inlet Item 4, wall of capsule Item 5, fine sieve type perforations Item 6, in the central filter sleeve Item 7, inside capsule washing drum item 8.

Figure 3 discloses radial cross-section of the capsule washing drum through section A-A inside Item 7, wall of capsule Item 6, central filter sleeve Item 5, axial drive shafts Item 2 and 3, washing inlet Item 1, supply and vacuum inlet Item 4.

Figure 4 discloses a front elevation cross-section of a capsule washing drum machine showing cabinet frame Item 1, control panels Item 2 and 3, water supply inlet.

Item 4, detergent mixing drawer Item 5, supply tube to heater tank Item 8, cold water supply tube to drawer Item 6, capsule washing drum Item 9, bearing block Item 10 and 11, retaining bolts Item 12, bearing or bearing material Item 14, washing inlet Item 22, axial drive shaft Item 13, electrical cable Item 7, capsule support frame Item 15, heater tank Item 17, electric motor and pump Item 20, capsule drive motor Item 21, drive belt Item 16.

Figure 5 discloses a rotary swivel joint showing suction port Item 17, stationary 90° inlet/outlet tube bend Item 7, rotary swivel fitted to the axial drive shaft on the capsule washing drum Item 10, male rotary body Item 9, female pin retainer Item 8, metal to metal outer seal Item 12, front seal Item 13 rear seal Item 16, central seal and retainer Item 11 and 14, bearing item 15.

Figure 6 discloses a schematic front elevation partially in section of a venturi jet high vacuum pump with a centrifugal air pump controller, to control suction strength, showing

high pressure water inlet Item 19, venturi inlet Item 4, venturi aperture Item 3, centrifugal air pump Item 1, air inlet Item 18, air chamber Item 2, peripheral air ducts Item 5, branch venturi inlet Item 6, to centre line of the 90° radius J/D tube bend Item 7.

Figure 7 shows a schematic of a centrifugal pump Item 1, air inlet Item 18.

Figure 8 discloses a side elevation view partially in section of a top loading capsule washing drum machine showing outer cabinet shell Item 9, adjustable levelling feet Item 10, capsule washing drum item 1, press twist lock pressure cap Item 33, top loading door Item 2, rotary transparent glass door Item 2, bearing block retaining axial drive shafts item 3, and 24, support frame for capsule drive shafts Item 4, and 17, water and detergent supply tube to heater tank item 5, water heater Item 16, controls Item 6, detergent drawer Item 7, water supply to drawer Item 8, suction inlet to pump from heater tank Item 11, electric motor Item 12, drives water-detergent pump Item 13, water-detergent supply tube Item 15, 26, and 20, to control valve and drain outlet Item 25, for supply to the capsule washing drum through the solenoid valve rotary swivel joint Item 23, vacuum tube Item 27, venturi tube Item 28, air supply tube Item 29, centrifugal air motor/pump Item 30, air inlet to pump Item 31, electric drive motor and reduction gearing Item 14, motor drive pulley Item 21, capsule washing drum drive pulley Item 32, drive belt Item 22, hot water in Item 19, cold water in Item 18.

Figure 9 discloses a diagrammatic view of a pressure/vacuum capsule washing drum machine showing washing machine cabinet shell Item 7, dual loading door Item 6, and the controls Item 1, and 2, detergent loading drawer Item 3.

Figure 10 shows a diagrammatic view of a front panel display, (sample only) showing an LCD or glow bar indicators Item 5, control dial Item 4.

Figure 11 discloses cross-section elevation view of a dual transparent inner rotary plug door and stationary transparent outer door showing capsule wall Item 12, inside capsule Item 15, fine perforations Item 16, central filter screen sleeve Item 14 bearing item 10,

bearing block Item 11, laundry loading port Item 13, pressure seals Item 7, outer cabinet shell Item 9, hinged door Item 3, hinge not shown transparent outer door Item 2, transparent inner door Item 1, bearing Item 6, retaining circlip Item 8, central dual door retaining unit Item 4, retaining countersunk screws Item 5, thrust pressure spring and backing rings Item 17.

Figure 12 discloses an axial cross-section of a circular sinuous or zig-zag type shape compression spring Item 1, with crests Item 3, and troughs Item 2. For applying continual pressure to the pressure seal around the laundry loading aperture with the dual inner door. For Figure 11 Item 17.

Figure 12A shows a radial cross-section of Figure 12 that fits between the two thrust rings for retaining pressure on the inner door seal, Figure 11, Item 7.

Figure 13 shows a bearing retaining circlip Item 1, compression holes Item 2, for Figure 11, Item 8.

Figure 14 shows bearing shells inner Item 1, and outer Item 2, with anti-rotation lugs Item 3, and 4, for Figure 11, Item 6.

Figure 15 shows an axial section of a backing ring Item 1, with two anti-rotational kinks Item 2.

Figure 15A shows an axial section of the opposite side backing ring Item 1 with anti-rotational kinks Item 2.

Figure 16 shows an axial section of a friction thrust ring Item 1.

Figure 17 shows a top longitudinal elevation view partially in section of a capsule washing drum showing axial drive shaft side vacuum conduit Item 1, liquid inlet and outlet Item 2,

vacuum inner conduit Item 3, wall of capsule Item 7, laundry inlet Item 5, capsule inner Item 6, sieve type filter screen Item 8, filter apertures Item 4.

Figure 18 shows a radial cross-section of a capsule washing drum through section A-A inside Item 6, wall of capsule Item 7, sieve type filter screen item 8, fine filter apertures Item 4, vacuum conduit Item 3, vacuum duct Item 1, liquid inlet and outlet Item 2, laundry loading aperture Item 5.

Figure 19 is a schematic diagram of a pressure washing and vacuum drying machine.

Operation of the pump drive motors, valves and capsule drive motor is effected by means of a programmable line computer (PLC) 100. A pressurised capsule 102 operating at between 15 to 20psc is filled with a charge of articles to be washed, rinsed and dried through a circular opening (not shown) closed by a door 104 in front of a rotary bearing assembly 106, which supports the capsule at one end of its axis of rotation. A similar bearing assembly 108 supports the capsule at the other end of its axis of rotation and a rotary sealing joint 110 communicates between the interior of the capsule via the bearing assembly and a solenoid valve assembly 112.

The latter includes three valves for controlling the admission of a water and detergent mixture into the capsule, the extraction of fluid from the capsule and the delivery of fresh rinsing water to the capsule. To this end, one of the valves communicates with a pipe 114 leading from the outlet of a pump 116 (driven by a motor 118 having a motor control means 120), to which heated water and detergent are supplied via pipes 122, and solenoid valve 124 from a heating tank 126 containing an immersion heater 128 and supplied via solenoid valve 130 from pipe 132 from a detergent reservoir 132. Cold water is conveyed to the heating tank 126 via the solenoid valve 124 from pipe 134, itself connected to a cold water main 136 via solenoid valves 138 and 140. Pipe 139 is connected to a hot water main 141 via valve 142.

Cold water can be conveyed to the detergent reservoir 132 by opening 140 and closing 138, to flush detergent via pipes 132 and valve 130 into the heating tank 126.

Similarly hot water from 141 may be conveyed into and through the reservoir 132 by opening valve 142 and closing valves 138 and 140.

The pump 116 can supply cold water at 175psi via pipes 144 to the 90 degree bend via bent pipe 146, from where it is exhausted via drain 148 to a sump 150. The latter includes an overflow 152 and a return pipe 154 which when valve 156 is open, provides a return for the water to the pump 116 from the venturi pump (not shown) formed in the 90 degree bend 158. For commercial/industrial applications, pump 116 will produce a higher pressure.

Air is admitted via an air inlet 160 and centrifugal air pump 162 and mixing device 164.

The speed of the air pump 162 is controlled by the PLC to control the suction generated by the venturi effect in the venturi pump 158.

At the end of a wash cycle and at the end of rinse cycle, water from the capsule is conveyed to the overflow or recirculated as described above.

The sump 156 is located in the base of a washing machine embodying the invention to assist in stabilising the machine when in use.

### Washing

During a washing cycle, the capsule is rotated to tumble the articles by an electric motor 16 having a motor control 168, and drive is transmitted from the motor to the capsule via two pulleys 170, 172 and an endless drive belt 174.

Water/detergent solution is pumped into the capsule at 175psi through a plurality of 1-2mm holes in a fine mesh filter plate 176. As shown in Figure 19, the plate is at one end of the capsule perpendicular to the axis around which the capsule rotates.

Heating the water/detergent mixture to a sufficiently high temperature and forcing it through the fine mesh filter plate 176 into the capsule interior and maintaining the latter at a positive pressure significantly above ambient pressure, results in a two plane washing medium of liquid and steam which in combination with the partial vacuum created at the end of the washing cycle by the action of the venturi suction pump 158, has been found to effect a very efficient washing of articles in the capsule.

### Rinsing

The rinse cycle may also be performed under positive pressure (ie above ambient) and the rinsing effect is seemingly enhanced by the partial vacuum created at the end of the rinse, by the action of the venturi pump 158.

### Drying

Drying of the washed and rinsed articles is effected very efficiently by continuing to run the venturi pump 158 after all water has been sucked from the capsule, and the partial vacuum created in the capsule assists in evaporation of residual moisture for the articles.

The operation of the various solenoid valves, the time during which they are opened or closed and the intervals between operation thereof, are controlled by the PLC 100, which being programmable permits different washing and rinsing cycles to be performed, in the same way the PLC 100 controls the operation of the various electric motors such as 118, 162 and 166.

CLAIMS

1. In a machine for washing and/or cleaning articles and which comprises a sealable enclosure for containing the articles to which cleaning liquid is to be supplied, the cleaning liquid is heated to a high temperature and forced into the enclosure under high pressure as finely dispersed or diffused droplets forming a mist or vapour so that a pressure greater than atmospheric is maintained in the enclosure to force the cleaning liquid into at least the surface if not through and into the very structure of the material from which the articles are formed, so as to assist the cleaning process.
2. In a machine as claimed in claim 1, the cleaning liquid is removed from the articles and the interior of the enclosure by means of a suction pump and replaced by clean liquid for rinsing, and if desired also heated to higher than ambient temperatures.
3. In a machine as claimed in claim 2, the liquid supplied for rinsing is also at higher than atmospheric pressure.
4. In a machine as claimed in claim 2 or 3, the rinsing liquid is also heated above ambient temperature.
5. In a machine as claimed in either of claims 3 or 4, the rinsing liquid is removed from the enclosure by suction.
6. In a machine as claimed in any of claims 1 to 5, means is provided for extracting residual moisture from the articles in the form of a suction pump, wherein during a drying cycle following washing and/or a rinsing cycle suction is employed to reduce the pressure on the downstream side of the enclosure substantially below atmospheric,

so that evaporative drying of moisture remaining on or in the material from which the articles are formed, occurs.

7. In a machine as claimed in claim 6, the vapour laden air produced by the evaporation is removed from the enclosure by the scavenging action of the air being drawn from the enclosure under the suction.
8. In a machine as claimed in any of claims 1 to 7, the enclosure comprises a rotatable drum, with a drive means for rotating the drum when in use and inlet and outlet means which permit relative movement to enable liquid and air to be supplied, to and drawn off therefrom, whilst the drum is rotating.
9. In a machine as claimed in any of claims 1 to 7, the enclosure comprises a housing within which a rotatable drum is mounted and the drum is adapted by means of openings to permit air and liquid to be forced axially and/or radially therethrough.
10. In a machine as claimed in claim 9, the openings comprise a large number of small apertures such as perforations in the wall of the drum.
11. In a machine as claimed in claim 9 and 10, the air and liquid mixture may be forced into the drum in a radial sense from the space around the drum within the housing, and be collected and conveyed away from the drum via a central porous or apertured hollow sleeve, mounted axially and centrally within the drum.
12. In a machine as claimed in any of claims 9 to 11, the housing forms part of the drum and rotate therewith, or is stationary so as to simplify the air and liquid supply to, and drainage from, the drum.
13. In a machine as claimed in claim 1, a reservoir is provided for containing a dry-cleaning fluid and valves and pumps are controlled by a computer to introduce a given volume of the fluid into the under positive pressure after articles have been inserted, and

the enclosure sealed to atmosphere and after rotation and thoroughly mixing the article, and the fluid, a suction pump is operated to evacuate the enclosure and remove the dry cleaning fluid and vapour therefrom.

14. In a machine as claimed in any of claims 1 to 13, the above atmospheric air pressure is obtained using an impeller, or turbine, or a centrifugal air pump.
15. In a machine as claimed in any of claims 1 to 14, the suction to produce depressed pressures below atmospheric is obtained using a venturi vacuum pump.
16. In a machine as claimed in claim 15, the venturi pump is a dual conical venturi jet high vacuum pump capable of generating a suction equivalent to 760mm Hg.
17. In a machine as claimed in any of claims 1 to 16, wherein a filter is provided at the inlet to the enclosure and liquid is finely dispersed and/or diffused on entry into the enclosure by forcing it therethrough.
18. In a machine as claimed in any of claims 1 to 17, means is provided to mix the liquid with air at elevated pressure, and optionally desired elevated temperature, before being forced under pressure through the inlet filter.
19. In a machine as claimed in either of claims 17 or 18, wherein the filter is a fine mesh filter.
20. In a machine as claimed in claim 1, the enclosure is in the form of an elliptical capsule mounted for rotation about an axis through the mid-point of the longer axis perpendicular to the latter and comprising a diameter of the cylindrical mid-region of the capsule, so that articles located therein will tend to fall from one end to the other as the capsule is rotated and thereby assist in the mixing of the liquids introduced into the capsule during the washing or cleaning process and to agitate the articles excessively during the drying cycle to further assist in removing moisture therefrom.

21. In a machine as claimed in claim 20, in which the capsule is to be loaded and unloaded through a circular opening in the front wall of a rectangular housing within which the capsule is located for rotation, and wherein the opening in the front housing wall is normally closed by a hinged circular door, the front opening (and in consequence the door also), is arranged coaxially relative to the axis of rotation of the capsule, and the capsule includes a circular opening which aligns with the circular front housing opening, and an annular seal is provided between the two openings to enable a positive pressure to be maintained in the capsule after the door has been closed.
22. In a machine as claimed in claim 21, a double door assembly is provided one closing an opening in the capsule wall and the other the opening in the front wall of the housing.
23. In a machine as claimed in claim 22, a seal is provided around each said door to seal it against the opening in the capsule wall, or the opening in the front housing wall, respectively.
24. In machine as claimed in any of claims 20 to 23, valve means is provided to control the admission of liquid and air to the capsule after the openings have been sealingly closed.
25. In a machine as claimed in claim 24, the valve means comprises a solenoid valves.
26. In a machine as claimed in any of claims 20 to 25, the capsule is mounted for rotation by two rotary support bearing assemblies, one surrounding the loading and unloading opening and the other attached to a diametrically opposite region of the cylindrical wall of the mid-region of the capsule coaxial with the first bearing assembly.
27. In a machine as claimed in claim 26, the second bearing assembly surrounds a circular region in the capsule wall opposite to the loading and unloading opening, and concentric pipe means having a rotary seal with the wall of the capsule, enables the

capsule to rotate whilst still being connected to the liquid and air supplies and also allows liquid and air to enter the capsule whilst the latter rotates.

28. In a machine as claimed in claim 27, the pipe means communicates with one or more fine mesh filters to disperse and diffuse incoming high pressure liquid and air into a fine mist.
29. In a machine as claimed in any of claims 24 to 28, the valve means controlling the passage of liquid and air into the capsule is arranged adjacent the pipe means where it extends through the capsule wall and is attached to, or forms part, of the capsule wall.
30. In a machine as claimed in claim 29, the pipe means and valve is surrounded by and extends axially through a hollow cylindrical drive shaft carrying a large diameter pulley which shaft extends through a support bearing assembly at the rear of the capsule and is joined to the capsule wall, and an electric motor, whose output shaft carries a complementary pulley aligned with the first mentioned pulley, allows drive to be transmitted to the drive shaft from the motor via a drive band, to rotate the capsule about the support bearing axis.
31. In a machine as claimed in claim 30, the bearing assembly is a so-called split bearing and is mounted on a sub-frame within the housing.
32. In a machine as claimed in any of claims 21 to 31, the opposite ends of the capsule include sieve-type filters and the pipe means delivers liquid and air to the two filters to enter the interior of the capsule from opposite ends thereof.
33. In a machine as claimed in any of claims 21 to 31, a hollow cylindrical sleeve extends across the interior of the capsule coaxial with the aligned support bearing axes which define the axis of rotation of the capsule, and the sleeve wall is perforated with tiny apertures through which the liquid and air exit into the interior of the capsule as a fine

mist diffused by the tiny perforations, which form a cylindrical fine mesh sieve type filter.

34. In a machine as claimed in claim 32 or 33, the fine mesh filter allows the incoming pressurised liquid and air to diffuse into the articles and produce a fast gaseous reaction inside the capsule due the liquid gaining heat energy by virtue of the liquid being forced through the plurality of tiny openings making up the filter mesh, so as to produce a sprinkler jet action for the gas-liquid mixture.
35. In a machine for washing as claimed in any of claims 21 to 34, a heater is provided to heat the water to boiling point so that at least part of the liquid entering the capsule is in the form of steam vapour.
36. In a machine as claimed in any of claims 21 to 35, wherein the shape of the capsule ensures that articles and liquid are tumbled from one end to the other under gravity as the capsule is rotated.
37. In a machine as claimed in any of claims 1 to 36, wherein the air expands due to its being heated after coming into contact with the steam so that a further increase in pressure within the capsule results causing the detergent suds to more thoroughly permeate the articles particularly where the latter are formed from woven fabric, so further assisting the release of dirt and particles causing stains and marks in the fabric.
38. In a machine as claimed in any of claims 21 to 37 for washing articles, wherein access to the enclosure is via a top opening, means is provided to extract the liquid and air from the end of the capsule opposite to the end containing the sealable opening through which access can be gained to the interior of the capsule, so that the garments tend to gravitate towards the end opposite to the opening under the suction effect, and in this way the weight of the garments at that end will tend to ensure that the capsule will always come to rest with its end containing the access aperture uppermost and in

alignment with an opening in the housing surrounding the capsule which in use will normally be closed by a lid.

39. A machine as claimed in any of the preceding claims 2 to 38, wherein the vacuum pump comprises a venturi tube includes a peripheral air duct, set around the outside of the venturi outlet, and this arrangement accelerates with flow, and the venturi tube is connected to a branch inlet at the mid point of a 90 degree radius bend relative to the centreline of the tube o/d to provide a strong vacuum suction, pump delivers water through the venturi supply tube, and an air blower outlet is connected via a pipe to the peripheral air chamber to control the air flow around the venturi, which in turn controls the amount of the suction.
40. A machine as claimed in claim 39, wherein an air pressure relief valve is provided which also controls the amount of suction created.
41. A machine as claimed in any of claims 21 to 40, wherein the vacuum, the temperature, and the pressure are displayed in an analogue or digital display (preferably an analogue LCD bar display) on the front of the machine housing.
42. A method of washing articles using a machine as claimed in any of claims 1 to 41, comprising the steps of:
- inserting an article or articles to be washed, into a sealable capsule,
  - sealing the capsule
  - introducing a detergent solution at or around boiling point together with steam into the sealed capsule, under a pressure greater than ambient
  - rotating the capsule to agitate the article(s) and effect a mixing of the liquid and steam therewith
  - pumping the liquid from the capsule after a predetermined time
  - introducing clean water into the capsule and further rotating same to rinse the articles
  - pumping the rinsing water from the capsule after a predetermined time

- continuing to pump the capsule so as to lower the pressure therein to below atmospheric for a further predetermined period of time to assist in evaporative drying of the article(s) therein
- removing the article(s) after establishing ambient pressure in the capsule.

43. A method as claimed in claim 42, wherein the suction pumping of liquids and air is effected using a venturi suction pump.

44. A machine as claimed in any of claims 1 to 41 which includes a reservoir of a volatile cleaning fluid such as isopropyl alcohol, means for introducing the fluid into the capsule with one or more items of clothing or the like which are to be dry cleaned, means for sealing the capsule so as to provide a gas-tight compartment, means for rotating the capsule in the range 80-100rpm, prior to unsealing the capsule to remove the clothing or like articles, and suction pump means, particularly a venturi vacuum pump, for extracting vapours and gases left over from the cleaning process.

1/10

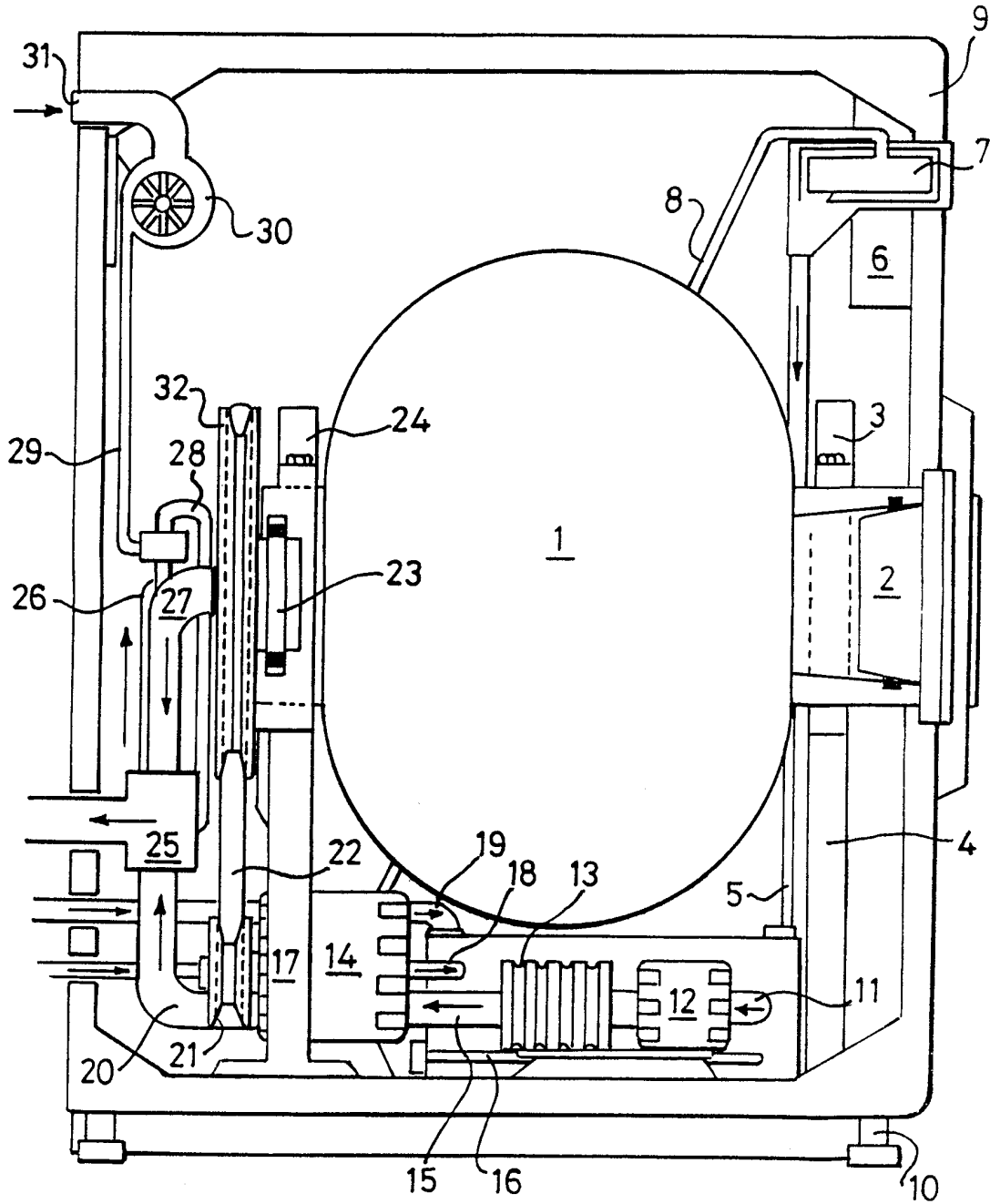

Fig. 1

2/10

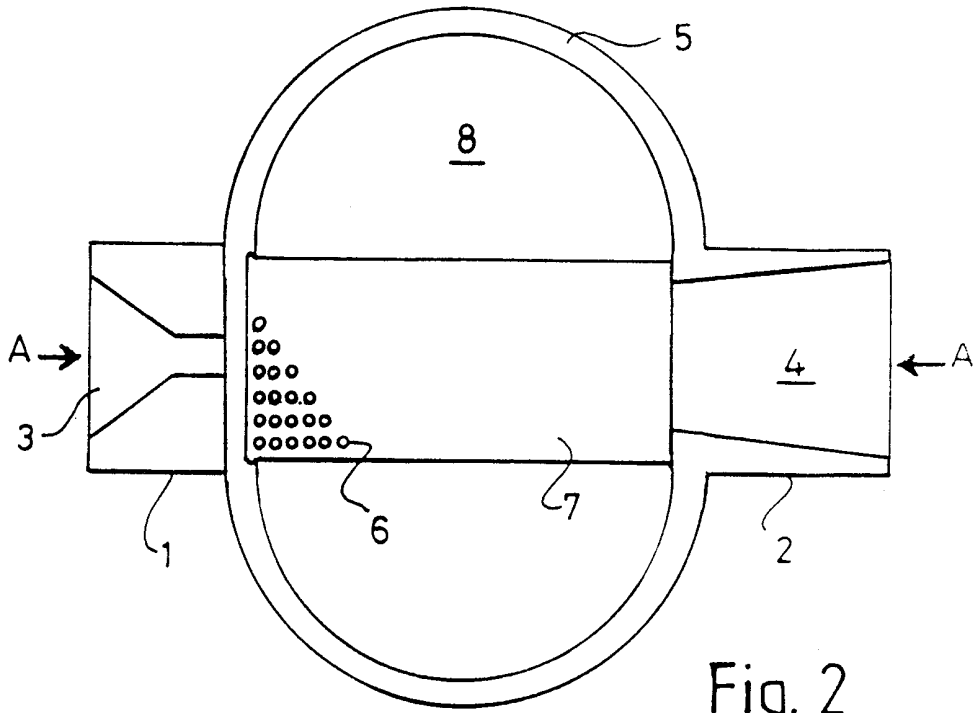

Fig. 2

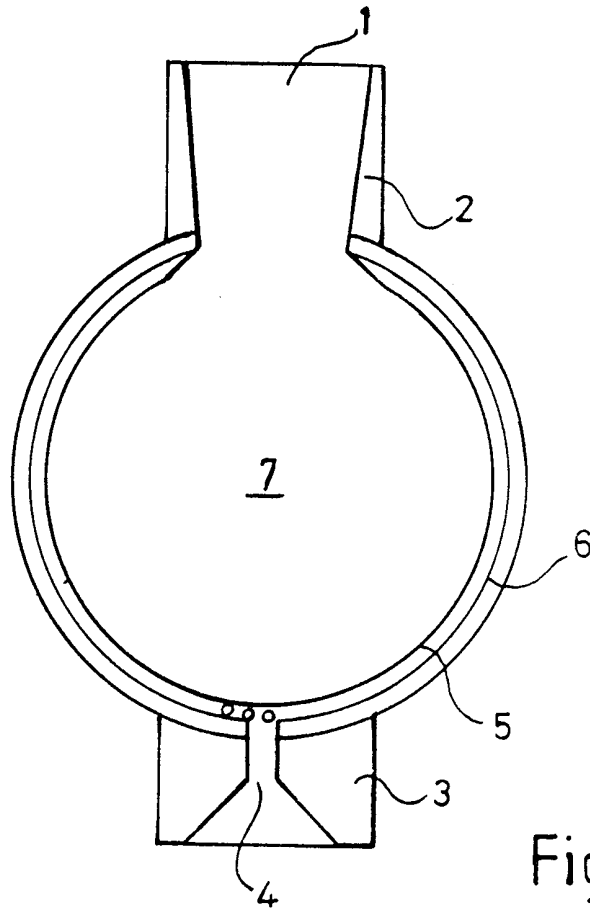

Fig. 3



4/10

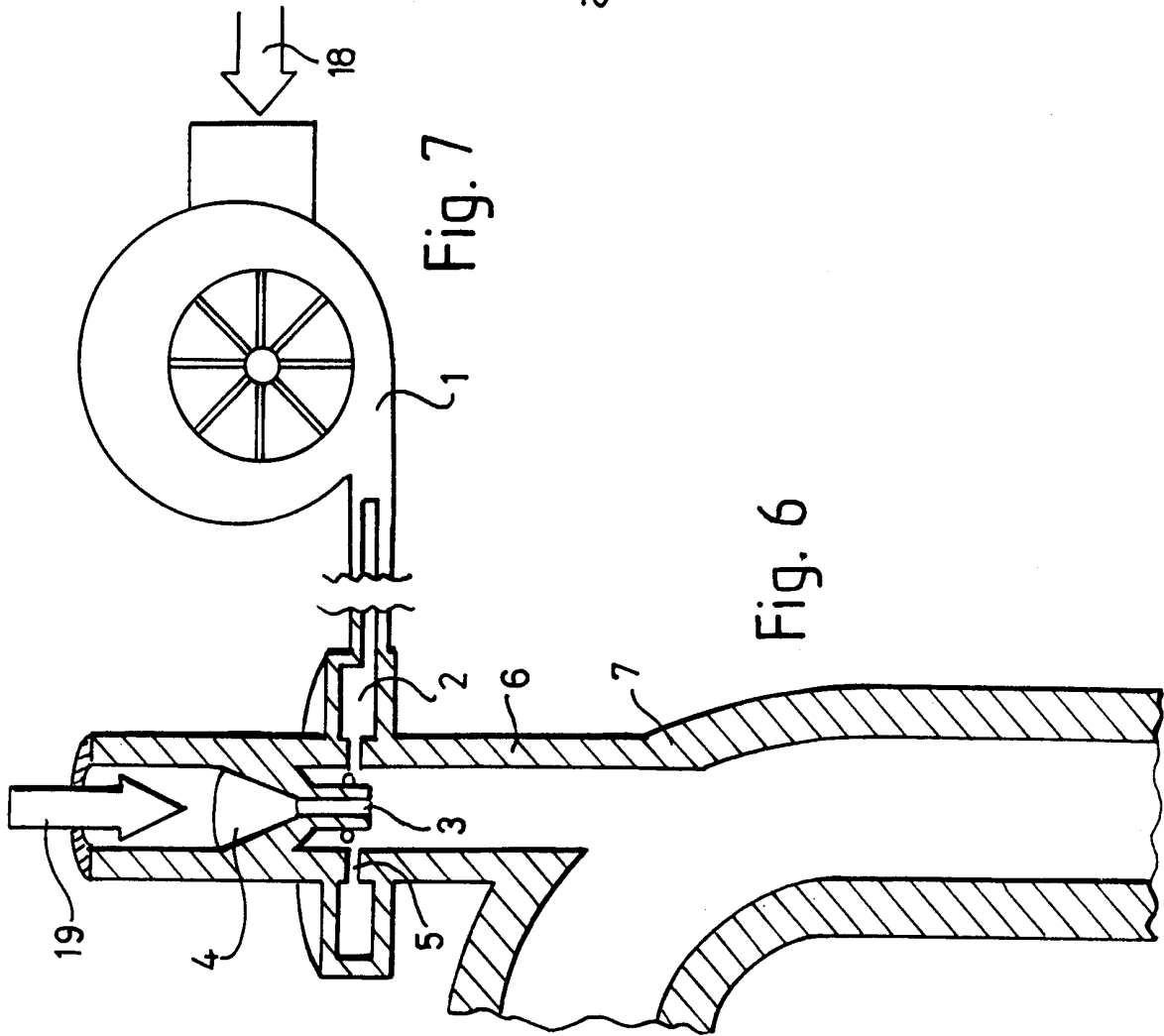

Fig. 7

Fig. 6

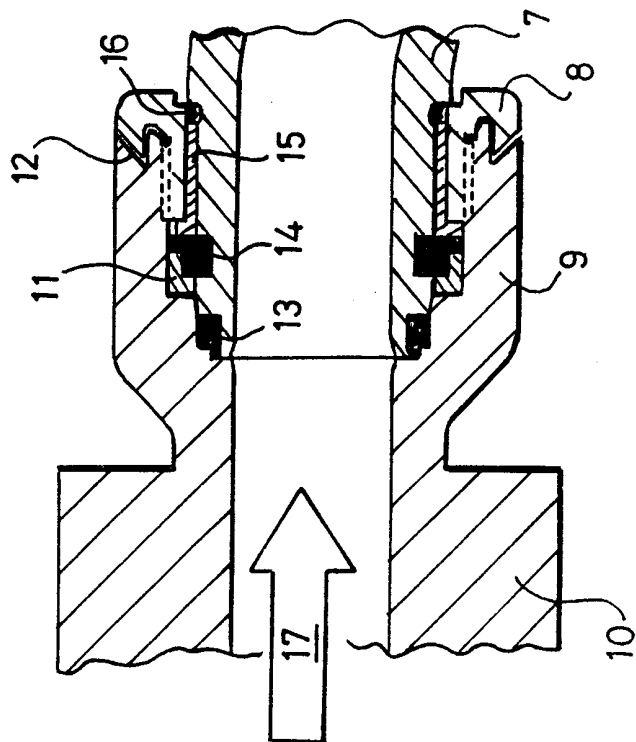
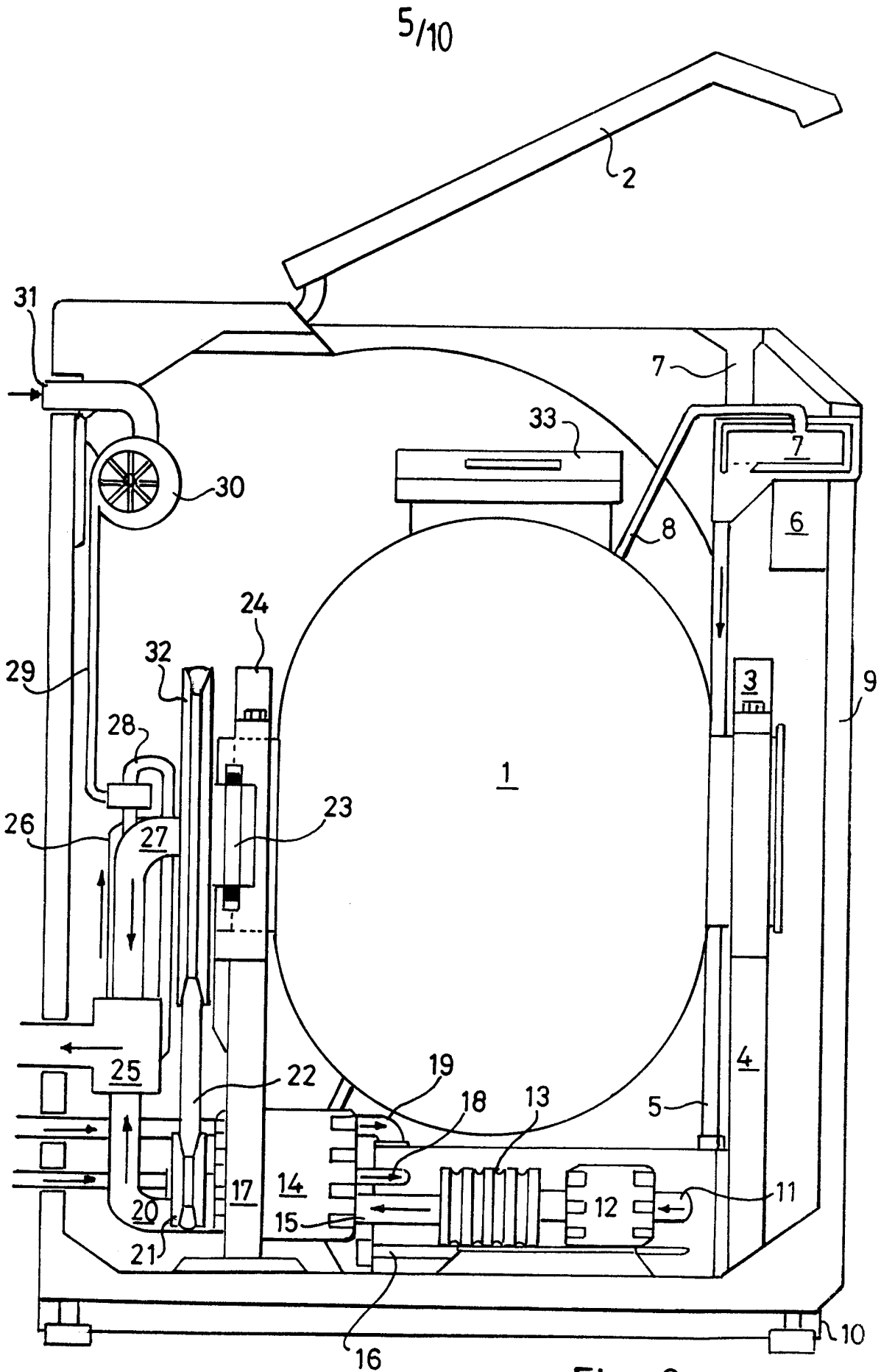

Fig. 5



6/10

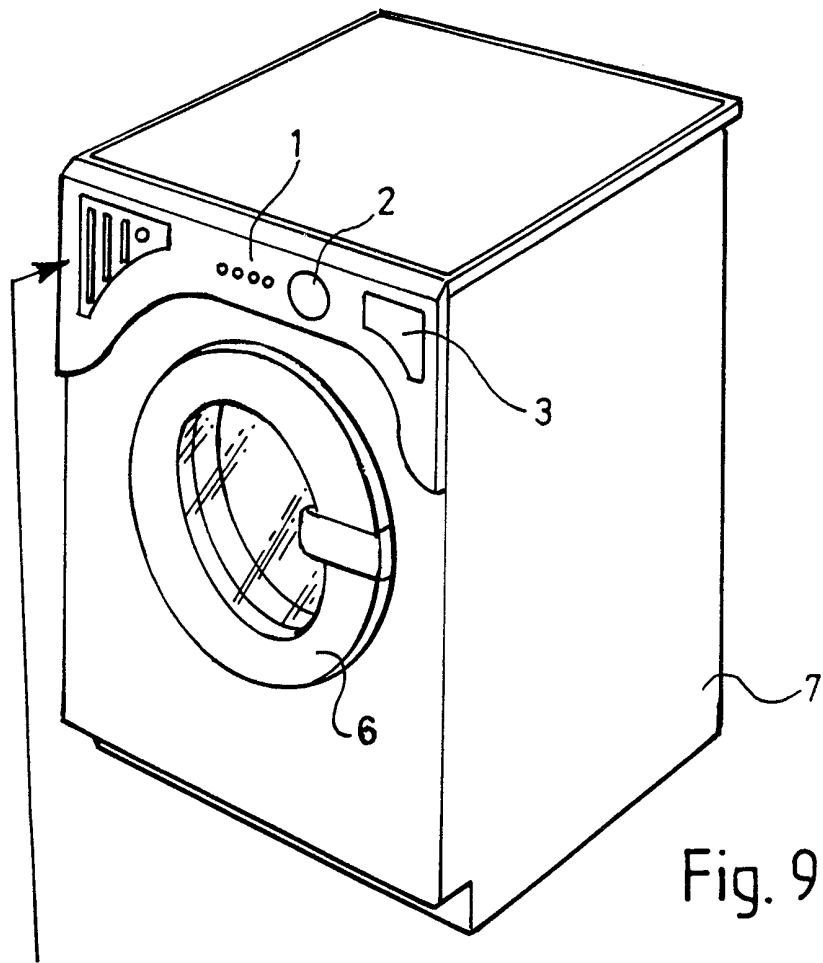

Fig. 9

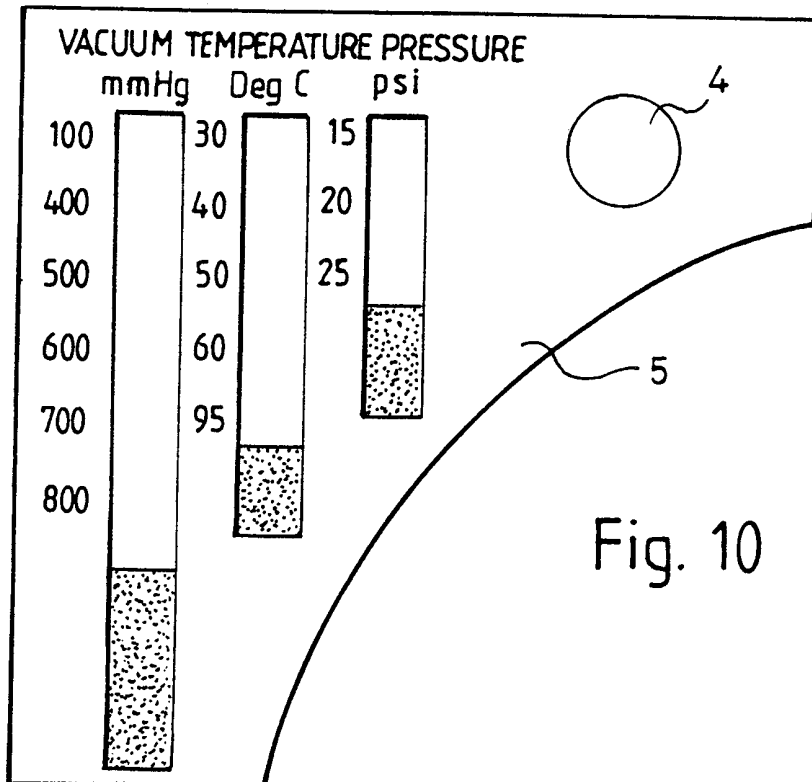
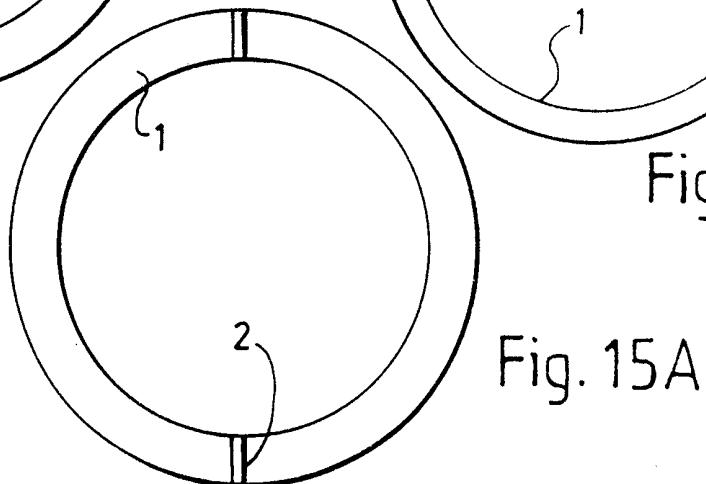
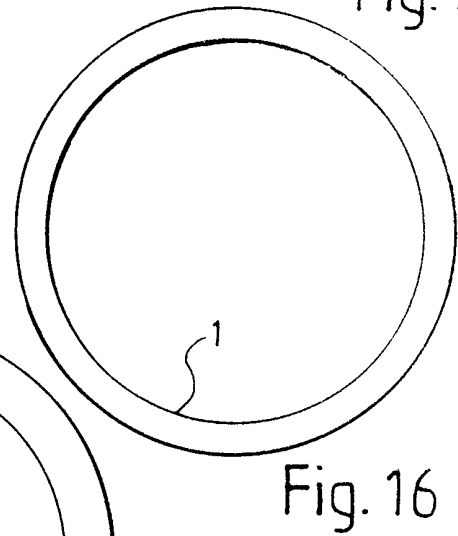
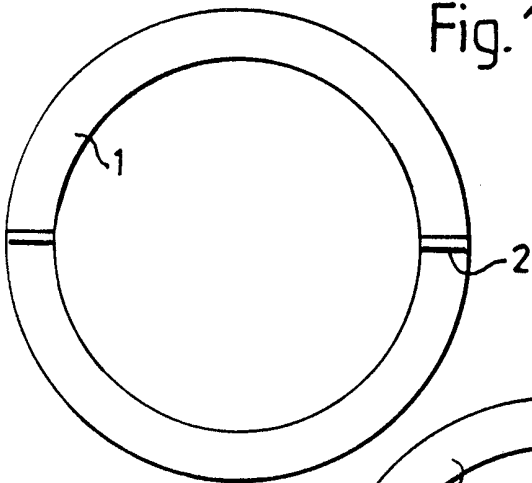
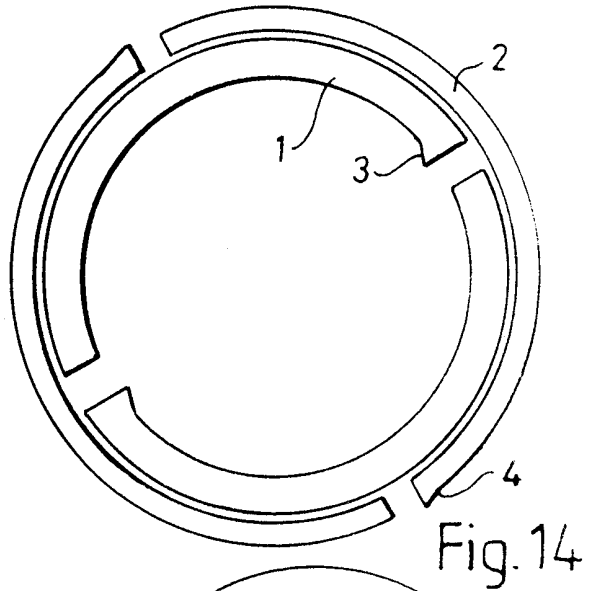
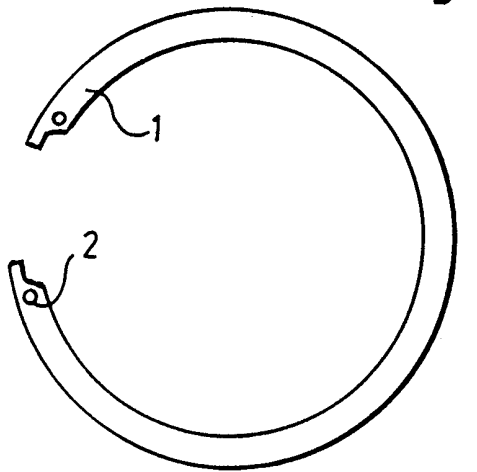
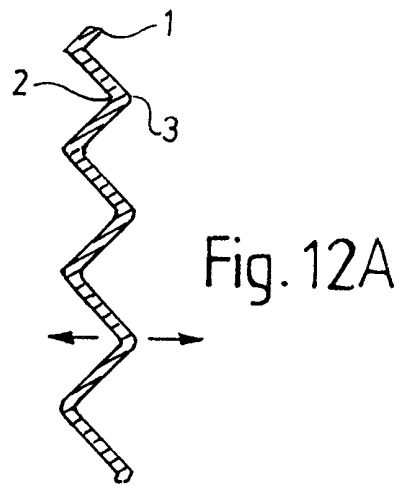
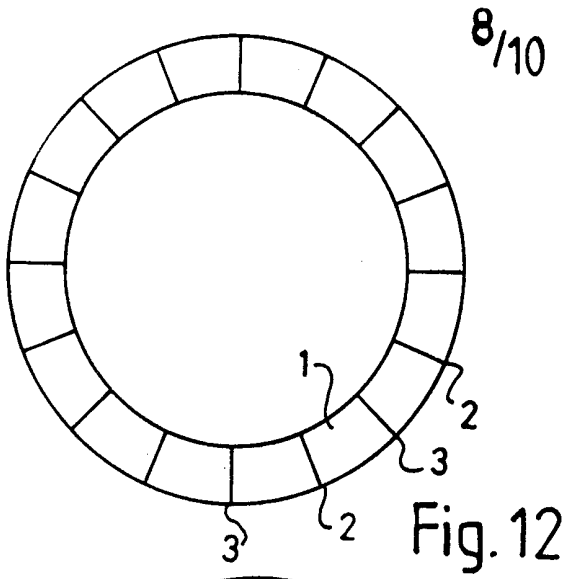

Fig. 10





9/10

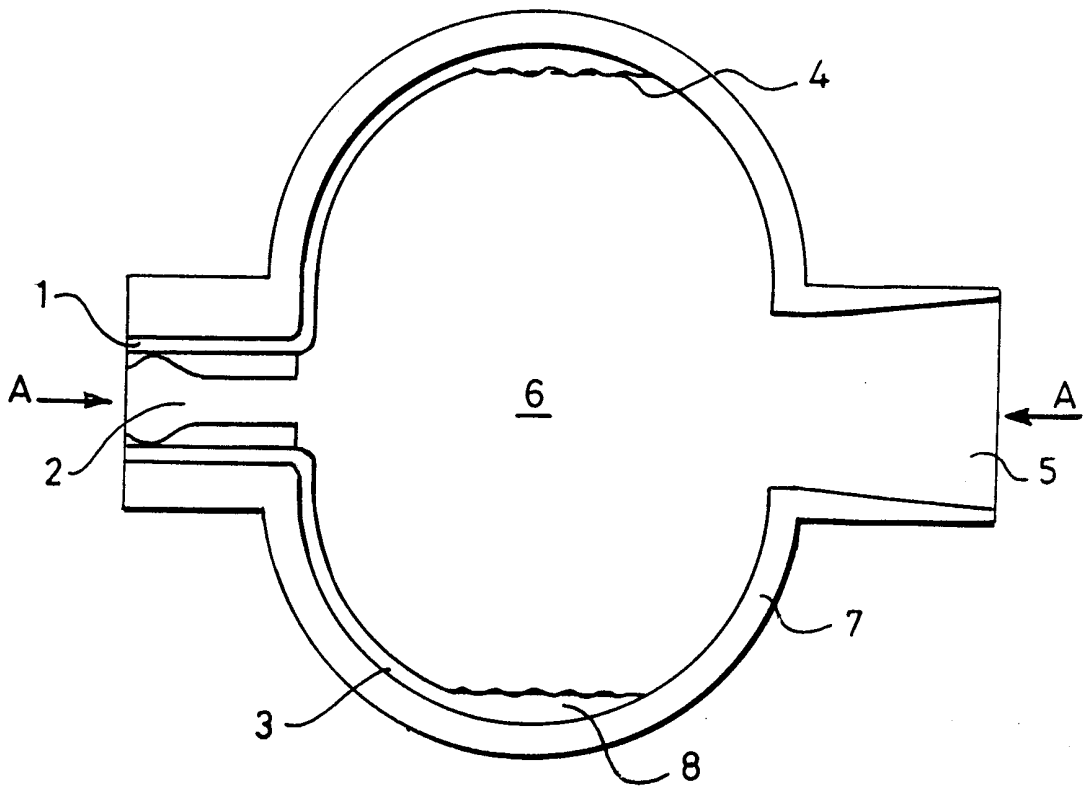

Fig. 17

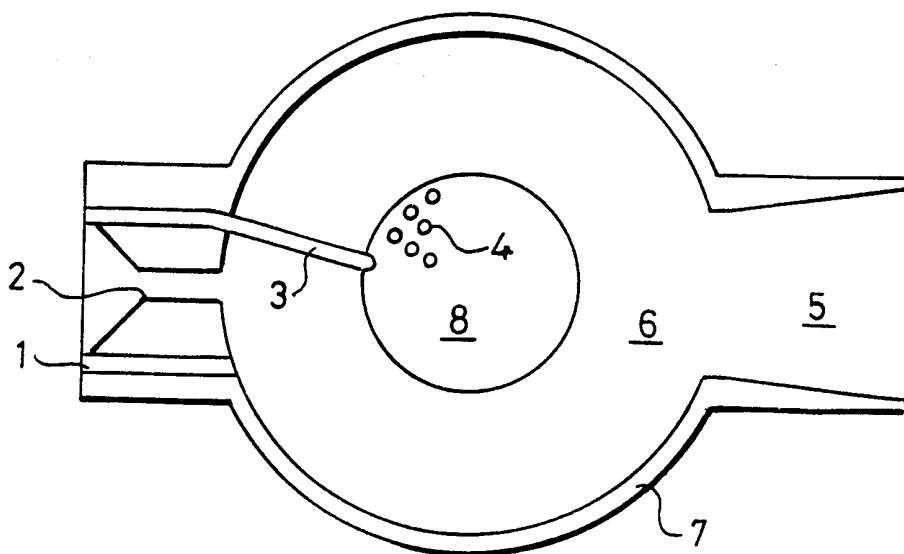

Fig. 18



# INTERNATIONAL SEARCH REPORT

International Application No

PCT/GB 00/01082

**A. CLASSIFICATION OF SUBJECT MATTER**  
 IPC 7 D06F35/00 D06F43/00

According to International Patent Classification (IPC) or to both national classification and IPC

**B. FIELDS SEARCHED**

Minimum documentation searched (classification system followed by classification symbols)

IPC 7 D06F

Documentation searched other than minimum documentation to the extent that such documents are included in the fields searched

Electronic data base consulted during the international search (name of data base and, where practical, search terms used)

EPO-Internal

**C. DOCUMENTS CONSIDERED TO BE RELEVANT**

Category °	Citation of document, with indication, where appropriate, of the relevant passages	Relevant to claim No.
A	WO 97 15709 A (T. PEETERS) 1 May 1997 (1997-05-01)  the whole document ---	1-5, 8-11,13, 42
A	GB 1 069 569 A (CONSTRUCTIEWERKHUIZEN EMILE D'HOOGHE P.V.B.A.) the whole document ---	1,14,18, 37,42
A	US 5 232 476 A (BAXTER INTERNATIONAL INC.) 3 August 1993 (1993-08-03)  column 6, line 42 -column 7, line 34; figures 4,5  ---  -/--	1,2, 6-10,13, 42,44

Further documents are listed in the continuation of box C.

Patent family members are listed in annex.

° Special categories of cited documents :

- \*A\* document defining the general state of the art which is not considered to be of particular relevance
- \*E\* earlier document but published on or after the international filing date
- \*L\* document which may throw doubts on priority claim(s) or which is cited to establish the publication date of another citation or other special reason (as specified)
- \*O\* document referring to an oral disclosure, use, exhibition or other means
- \*P\* document published prior to the international filing date but later than the priority date claimed

- \*T\* later document published after the international filing date or priority date and not in conflict with the application but cited to understand the principle or theory underlying the invention
- \*X\* document of particular relevance; the claimed invention cannot be considered novel or cannot be considered to involve an inventive step when the document is taken alone
- \*Y\* document of particular relevance; the claimed invention cannot be considered to involve an inventive step when the document is combined with one or more other such documents, such combination being obvious to a person skilled in the art.
- \*Z\* document member of the same patent family

Date of the actual completion of the international search

3 July 2000

Date of mailing of the international search report

10/07/2000

Name and mailing address of the ISA

European Patent Office, P.B. 5818 Patentlaan 2  
 NL - 2280 HV Rijswijk  
 Tel. (+31-70) 340-2040, Tx. 31 651 epo nl,  
 Fax: (+31-70) 340-3016

Authorized officer

Courrier, G

INTERNATIONAL SEARCH REPORT

Inte. onal Application No  
PCT/GB 00/01082

C.(Continuation) DOCUMENTS CONSIDERED TO BE RELEVANT

Category	Citation of document, with indication, where appropriate, of the relevant passages	Relevant to claim No.
A	DE 42 36 873 A (H. FALLER) 5 May 1994 (1994-05-05)  claims; figures ----	1-5, 8-11, 13, 42
A	US 5 459 945 A (A. SHULENBERGER) 24 October 1995 (1995-10-24) abstract; figures ----	1, 6-8, 42
A	US 2 335 560 A (N. CRANE) 30 November 1943 (1943-11-30)  the whole document -----	1, 2, 12, 20, 26, 36, 42

# INTERNATIONAL SEARCH REPORT

information on patent family members

International Application No

PCT/GB 00/01082

Patent document cited in search report	Publication date	Patent family member(s)	Publication date
WO 9715709 A	01-05-1997	BE 1009718 A	01-07-1997
		AU 7270996 A	15-05-1997
GB 1069569 A		FR 1412111 A	05-01-1966
		NL 6411899 A	26-04-1965
US 5232476 A	03-08-1993	US 5106404 A	21-04-1992
		AU 3728893 A	05-10-1993
		MX 9301156 A	01-09-1993
		US 5346534 A	13-09-1994
		WO 9317770 A	16-09-1993
		ZA 9301373 A	23-09-1993
		AT 136228 T	15-04-1996
		AU 634673 B	25-02-1993
		AU 8613391 A	30-03-1992
		BR 9106174 A	16-03-1993
		CA 2067163 A	13-03-1992
		DE 69118508 D	09-05-1996
		DE 69118508 T	22-08-1996
		DK 498877 T	06-05-1996
		EP 0498877 A	19-08-1992
		ES 2088017 T	01-08-1996
		IE 70754 B	30-12-1996
		JP 8032289 B	29-03-1996
		JP 5500473 T	04-02-1993
		MX 9101072 A	04-05-1992
		NO 180324 B	23-12-1996
		WO 9204101 A	19-03-1992
		US 5192340 A	09-03-1993
US 5304253 A	19-04-1994		
ZA 9107047 A	27-05-1992		
DE 4236873 A	05-05-1994	NONE	
US 5459945 A	24-10-1995	NONE	
US 2335560 A	30-11-1943	NONE	