



- (51) International Patent Classification:
A61B 17/86 (2006.01)
- (21) International Application Number:
PCT/US2013/042170
- (22) International Filing Date:
22 May 2013 (22.05.2013)
- (25) Filing Language: English
- (26) Publication Language: English
- (30) Priority Data:
61/650,364 22 May 2012 (22.05.2012) US
- (71) Applicant: LIFENET HEALTH [US/US]; 1864 Concert Drive, Virginia Beach, VA 23453 (US).
- (72) Inventors: CHEN, Jingsong; 1864 Concert Drive, Virginia Beach, VA 23453 (US). SANDER, Thomas; 1864 Concert Drive, Virginia Beach, VA 23453 (US). PHELPS, Dennis, L.; 1864 Concert Drive, Virginia Beach, VA 223453 (US). PRITCHARD, Andy; 1864 Concert Drive, Virginia Beach, VA 23453 (US).
- (74) Agents: LEE, H., Janice et al.; Morgan, Lewis & Bockius LLP, 1111 Pennsylvania Avenue, NW, Washington, DC 20004 (US).

(81) Designated States (unless otherwise indicated, for every kind of national protection available): AE, AG, AL, AM, AO, AT, AU, AZ, BA, BB, BG, BH, BN, BR, BW, BY, BZ, CA, CH, CL, CN, CO, CR, CU, CZ, DE, DK, DM, DO, DZ, EC, EE, EG, ES, FI, GB, GD, GE, GH, GM, GT, HN, HR, HU, ID, IL, IN, IS, JP, KE, KG, KM, KN, KP, KR, KZ, LA, LC, LK, LR, LS, LT, LU, LY, MA, MD, ME, MG, MK, MN, MW, MX, MY, MZ, NA, NG, NI, NO, NZ, OM, PA, PE, PG, PH, PL, PT, QA, RO, RS, RU, RW, SC, SD, SE, SG, SK, SL, SM, ST, SV, SY, TH, TJ, TM, TN, TR, TT, TZ, UA, UG, US, UZ, VC, VN, ZA, ZM, ZW.

(84) Designated States (unless otherwise indicated, for every kind of regional protection available): ARIPO (BW, GH, GM, KE, LR, LS, MW, MZ, NA, RW, SD, SL, SZ, TZ, UG, ZM, ZW), Eurasian (AM, AZ, BY, KG, KZ, RU, TJ, TM), European (AL, AT, BE, BG, CH, CY, CZ, DE, DK, EE, ES, FI, FR, GB, GR, HR, HU, IE, IS, IT, LT, LU, LV, MC, MK, MT, NL, NO, PL, PT, RO, RS, SE, SI, SK, SM, TR), OAPI (BF, BJ, CF, CG, CI, CM, GA, GN, GQ, GW, ML, MR, NE, SN, TD, TG).

Published:
— with international search report (Art. 21(3))

(54) Title: CORTICAL BONE PIN

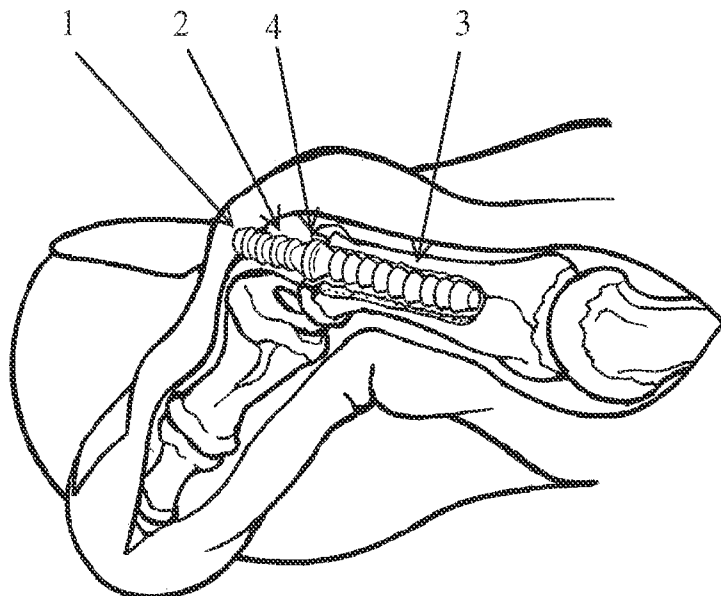

FIG. 5

(57) Abstract: A pin made of cortical bone may be inserted into adjoining bones of a toe to align and secure the bones. The pin may have barbs to prevent migration of the pin. The pin may include a shoulder to further prevent migration of the pin from the bones, to increase the strength of the pin, and to increase the surface area between the bone pin and the host bone. The pin may further include flattened portions on its circumference to aid in rotating the pin during insertion. The pin may be treated to reduce brittleness.



CORTICAL BONE PIN

[0001] This application claims the benefit of U.S. Provisional Application No. 61/650,364 filed May 22, 2012, which is hereby incorporated by reference.

BACKGROUND OF THE INVENTION

FIELD OF THE INVENTION

[0002] The present invention relates to a pin for use in aligning and securing bones, and more particularly, to such a pin made of cortical bone that may be used for aligning and securing bones of a toe of a human patient. The present invention may also be used for aligning and securing bones of a hand, forefoot, or forearm of a patient. In particular, a fractured bone of a hand, foot, or forearm may be treated by inserting a pin according to the present invention into at least one segment of the fractured bone.

DISCUSSION OF THE RELATED ART

[0003] Certain deformities such as hammer toe result in the bones of a toe being arranged in a highly abnormal manner. In some cases, the treatment for such deformities involves inserting a K-wire (Kirschner wire) through the tip of the toe and penetrating through the bones of the toe so as to align the bones in a more ordinary manner. According to this procedure, the K-wire exits the surface of the skin for a certain period of time. This method suffers from several drawbacks. First, the K-wire is exposed, allowing for the K-wire to slide out of the toe. Another drawback is the insertion point is an open wound, thus raising the possibility of infection.

[0004] As another treatment, a metal pin may be inserted through an exposed interphalangeal

joint. This method involves the steps of (i) incising at the appropriate joint, (ii) driving a drill pin into the shaft of the appropriate phalanges, (iii) measuring, with a depth gauge, the depths of the intramedullary canals, (iv) selecting a pin of an appropriate length dependent on the measurements of the lengths of the intramedullary canals, (v) inserting the pin into the proximal phalange, and (vi) placing the distal phalange over the pin. This method suffers from the several drawbacks. First, the metal pin is not resorbable nor is it removable. Another drawback is the pin may migrate into one of the phalanges (especially the proximal phalange). This may cause instability and a failure to fuse. In extreme cases, one of the phalanges (especially the distal phalange) may become detached from the pin.

SUMMARY OF THE INVENTION

[0005] Accordingly, the present invention is directed to a pin that substantially obviates one or more of the problems in the prior art.

[0006] In one aspect of the invention, a pin has an elongated body of a substantially cylindrical shape. The pin may include a raised portion, or a plurality of raised portions, that may be formed of peaks and troughs. Such raised portions are referred to herein as “barb(s).” The barbs may extend around the entire circumference of the pin. In certain embodiments, however, the barbs are located on only a portion of the circumference of the pin. The remainder of the circumference of the pin may be flattened. In certain embodiments, voids are created along the circumference of the barbs to create spokes. The pin may include a protrusion (also referred to as a “shoulder”) extending outward from the pin. In some embodiments, the pin is made of cortical bone. In some embodiments, the cortical bone pin is treated to reduce brittleness.

BRIEF DESCRIPTION OF THE DRAWINGS

[0007] The accompanying drawings, which are included to provide a further understanding of the invention and are incorporated in and constitute a part of this specification, illustrate embodiments of the invention and together with the description serve to explain the principles of the invention. In the drawings:

[0008] FIG. 1 is a perspective view of a pin according to a first exemplary embodiment of the present invention.

[0009] FIG. 2 is a top view of a pin according to a first exemplary embodiment of the present invention.

[0010] FIG. 3 is a side view of a distal portion of a pin according to a first exemplary embodiment of the present invention.

[0011] FIG. 4 is a side view of a proximal end of a pin according to a first exemplary embodiment of the present invention.

[0012] FIG. 5 shows a pin according to a first exemplary embodiment of the present invention partially inserted into the toe of a patient.

[0013] FIG. 6 shows a pin according to a first exemplary embodiment of the present invention fully inserted into the toe of a patient.

[0014] FIG. 7 is a top view of a double-ended drill used to drill out the intermedullary canals of the bones into which a pin according to the present invention is to be inserted.

[0015] FIG. 8 is an end view of a double-ended drill used to drill out the intermedullary canals of the bones into which a pin according to the present invention is to be inserted.

[0016] FIG. 9 is a perspective view of a pin according to a second exemplary embodiment of

the present invention.

[0017] FIG. 10 is a top view of a pin according to a second exemplary embodiment of the present invention.

[0018] FIG. 11 is a detailed view of a barb of a pin according to a second exemplary embodiment of the present invention.

[0019] FIG. 12 is a perspective view of a pin according to a third exemplary embodiment of the present invention.

[0020] FIG. 13 is an end view of a pin according to a third exemplary embodiment of the present invention.

[0021] FIG. 14 is a perspective view of a pin according to a fourth exemplary embodiment of the present invention.

[0022] FIG. 15 is an end view of a pin according to a fourth exemplary embodiment of the present invention.

[0023] FIG. 16 is a top view of a pin according to a fifth exemplary embodiment of the present invention.

[0024] FIG. 17 is a view of a pin according to a fifth exemplary embodiment of the present invention taken along section line 17-17 in FIG. 16.

[0025] FIG. 18 is a perspective view of a pin according to a fifth exemplary embodiment of the present invention and an insertion tool used to insert a pin according to a fifth exemplary embodiment of the present invention into the bones of a patient.

DETAILED DESCRIPTION OF THE PREFERRED EMBODIMENTS

[0026] Reference will now be made in detail to the preferred embodiments of the present

invention, examples of which are illustrated in the accompanying drawings.

[0027] FIGs. 1-4 show a pin 1 according to a first exemplary embodiment of the present invention. As shown in FIG. 1, the pin 1 has a substantially cylindrical shape.

[0028] As shown in FIGs. 1-2, in one embodiment, barbs 2 are provided on the distal end of the pin. Barbs are preferred over threads as the torque required to install a threaded pin may stress the pin to failure. As shown in FIG. 3, the profile of the barbs 2 may be such that, as a barb 2 proceeds from a distal end to a proximal end, the barb 2 slopes gradually from a trough 5 to a crest 6, with an abrupt slope from a crest 6 to a trough 5. This way, the barbs 2 are designed to resist migration of the pin 1 toward a proximal direction after the pin has been inserted into the bone of a toe of a patient. Similarly, the barbs 2 are designed to resist migration of a distal bone of a patient from the pin 1. The barbs 2 may extend completely around the circumference of the pin 1 according to the invention.

[0029] As shown in FIGs. 1-2, in one embodiment, a shoulder 4 is provided. This shoulder 4 may have a diameter greater than the remainder of the pin 1. For example, the shoulder 4 may have a diameter that is approximately 110%, 115%, 120%, 130%, 150%, 170%, 200%, 250%, 300% or 400% of the diameter of the remainder of the pin 1. The diameter of the remainder of the pin 1 may be approximately 1 mm, 2 mm, 3 mm, or 4 mm. The shoulder 4 may have sloped surfaces 9 and 10 on either side of the apex of the shoulder 4 as depicted in FIGs. 1 and 2. According to the invention, surfaces 9 and 10 may also be contoured, convex, concave, stepped, or irregular to complement the surface area created inside the bone. For example, the internal surface area of the bone may be created and/or shaped by the drilling of the intramedullary canals using a drill bit having various profiles. FIGs. 1, 2 and 7 show a sloped profile; of course,

drill bits and shoulder surfaces having other profiles may be employed in other embodiments. In some aspects, pins are designed such that the surface(s) of the pin are complementary to the internal surface area of the bone to maximize, to the extent possible, surface proximity and fusion efficiency. Additionally, the shoulder 4 is designed to prevent migration of the pin 1 into a proximal bone. Thus, it is not necessary that the length of the pin equal the combined lengths of the intramedullary canals of the phalanges. By contrast, in the prior art practice, the length of the pin must be very nearly equal to the combined lengths of the intramedullary canals of the phalanges. In these systems, incorrect selection of the length of the pin may result in pin migration, resulting in instability and failure to fuse. Further, in this application the bone pin undergoes relatively large stress at the proximal bone-bone pin interface. However, according to the invention, because the shoulder 4 has a relatively large diameter, the pin 1 is well suited to undergo the stresses at the proximal bone-bone pin interface. Additionally, as mentioned above, in one embodiment the sloped surfaces 9 and 10 of shoulder 4 increase the surface area of contact between the pin 1 and the host bone, which tends to promote fusion. It being understood that other shoulder profiles may provide improved surface area proximity and fusion efficiency in the case where drill bits having other profiles are employed for example.

[0030] In one embodiment, barbs 3 are provided on the proximal end of the pin 1. As shown in FIG. 4, these barbs 3 are similar to barbs 2; however, barbs 3 may have a profile such that, as the barb 3 proceeds from a distal end to a proximal end, the barb 3 slopes abruptly from a trough 7 to a crest 8 and slopes gradually from a crest 8 to a trough 7. This way, the barbs 3 are designed to resist migration of the pin 1 toward a distal direction. The barbs 3 may extend completely around the circumference of the pin 1 according to the invention.

[0031] In one aspect, the diameters of the features of the proximal portion of the pin may be slightly larger than the diameters of the corresponding features of the distal portion of the pin. In other words, the diameter of crest 8 may be slightly larger than the diameter of crest 6, and the diameter of trough 7 may be slightly larger than the diameter of trough 5.

[0032] The pins of the invention may be made from cortical bone. The cortical bone may be human cortical bone or animal cortical bone. It is understood that pins and bone pins are used interchangeably throughout the description and that a pin made of cortical bone is one preferred material of construction for the pin. In addition to cortical bone, other resorbable and biocompatible materials may be used. Additionally, non-metallic synthetics may be used for the pin material. Cortical bone, resorbable and biocompatible materials, and non-metallic synthetics are preferred pin materials compared to metals to promote enhanced fusion.

[0033] As described in further detail below, a bone pin according to the present invention may be made and treated according to the following procedures.

[0034] In certain embodiments, the bone pin is cleaned according to the methods described in U.S. Patent numbers 5,556,379; 5,797,871; 5,820,581; 5,976,104; 5,977,034; and 6,024,735.

[0035] The bone pin may be machined by a CNC machine. Alternatively, other manufacturing methods may be used.

[0036] In another embodiment, after the bone pin has been cleaned and disinfected, it may be demineralized in accordance with the disclosures of U.S. Patent numbers 6,534,095; 6,830,763; 6,189,537; and 6,305,379, all of which are hereby incorporated by reference. This reduces or eliminates the likelihood of disease transmission and/or improves fusion. The demineralization may be a surface demineralization. The surface demineralization may be applied to the whole

body or a portion of the bone pin 1, such as the shoulder 4. In some embodiments, the demineralized portion of the bone tissue is at least 10%, 20%, 30%, 40%, 50%, 60%, 70%, 80%, or 90% (v/v %) of the bone tissue. In other embodiments, the demineralized portion of the bone tissue is less than 10%, 20%, 30%, 40%, 50%, 60%, 70%, 80%, or 90% (v/v %) of the bone tissue. This may be accomplished by covering the portions of the bone pin not to be demineralized with acid resistant materials, such as paraffin, with the areas to be demineralized, such as shoulder 4, left exposed. For example, the portions of the bone pin 1 labeled "A" in FIG. 2 may be covered with a paraffin, while the portion of the bone pin 1 labeled "B" in FIG. 2 may be exposed. The bone pin may then be treated with an acid solution for a desired amount of time. The acid-resistant material, such as paraffin, may then be removed. In one aspect, this may be accomplished by first refrigerating the bone pin and then detaching the paraffin shell from the bone pin. The absorbed acid may then be removed by rinsing. The depth of demineralization can be controlled by adjusting the type and concentration of the acid solution, and/or the exposure time of the bone pin to the acid solution. The demineralization may also be a full demineralization of a portion of the bone pin, such as the shoulder 4, to enhance bone incorporation and/or create a structural zone with more flexibility.

[0037] The above-described "partial demineralization" technique can be applied to other types of cortical or cortical-cancellous bone grafts to control the exact area and depth of demineralization. For example, a cranial bone flap can be processed through such method to be osteoinductive thus promoting new bone formation and fusion to the adjacent host bone, while still maintaining certain mechanical integrity. The treated graft is thus able to withstand surgical fixation through metal plates and screws. The exterior (i.e. abaxial) surface of the cranial bone

flap, facing the outside of a body, can be first covered with acid resistant materials such as paraffin. The cranial bone flap may then be treated with acid solution to demineralize the interior (i.e. adaxial) surface of the cranial bone flap, facing the cranial cavity. Of course, as is readily understood by those skilled in the art, acid resistant materials may be employed in various patterns and arrangements in order to demineralize certain portions and leave others untreated as desired.

[0038] In another embodiment, the bone pin may be treated in accordance with the disclosures in U.S. Patent numbers 6,293,970, 6,544,289, and 7,063,726, all of which are hereby incorporated by reference, which act to improve the preservation of the bone pin. In particular, the following advantages over conventional methods of preservation may be realized. One conventional method of preservation is freezing the bone graft with a liquid. This requires keeping the bone graft in a very cold (such as -80°F) environment, which may be difficult and expensive. Another conventional method of preservation is freeze-drying the bone graft. However this method results in a brittle bone graft. Further, the surgeon must rehydrate the bone graft prior to insertion into a patient. By contrast, by treating the bone pin in accordance with the disclosures in U.S. Patents 6,293,970, 6,544,289, and 7,063,726, the bone pin may be stored at room temperature, the bone pin is not brittle, and a surgeon need only briefly rinse the bone pin prior to insertion into a patient.

[0039] An exemplary method of inserting the above-described cortical bone pin into a patient is described with reference to FIGs. 5-8. The method described below is similar to the method described by Dr. Stephen J. Miller in *Hammer Toe Correction by Arthrodesis of the Proximal Interphalangeal Joint Using a Cortical Bone Allograft Pin*, Journal of the American Podiatric

Medical Association, Vol. 92, No. 10, pp. 563-69 (2002). First, as with the method described by Dr. Miller, an incision is made above the appropriate joint. The subcutaneous layer is separated. The extensor tendons are retracted or separated, the collateral ligaments are incised, and the joint is brought to the incision. The cartilage from the joint surfaces is then removed. The intramedullary canals of the proximal and distal bones are drilled. A double-ended drill, such as that shown in FIGs. 7-8 (described below), may be used for this step. Migration of the bone pin 1 of the present invention into the proximal phalange is prevented by the shoulder 4. Accordingly, unlike the method described by Dr. Miller, although the surgeon may measure the depths of the intramedullary canals when using a bone pin according to the present invention, it is not necessary to do so. Further, although a surgeon may do so, it is not necessary to cut a pin to the length of the combined measured depths. According to one aspect of the invention, the bone pin 1 may be inserted into the proximal phalange with the shoulder 4 abutting the end of the phalange as shown in FIG. 5. The distal phalange may then be brought up over the bone pin 1 and may be inserted onto the bone pin 1, as shown in FIG. 6. The incision is then closed.

[0040] The double-ended drill referenced in the process above will now be described with reference to FIGs. 7-8. The double-ended drill 170 may include a distal side 173 and a proximal side 175 separated by a hilt stop 178, which may be located at the center of the double-ended drill 170. The drill may include a distal drill 172 and proximal drill 174 and hilt stops 176 and 177. The drill may further include hex flats 182. The drill may also include a detent ball 183 on each side of the drill. The hilt stop 178, hex flats 182 and detent balls 183 may be used in accommodating the drill in standard drill chucks. The overall length 171 of the drill may be from about 3 inches to about 6 inches. The distal drill 172 and proximal drill 174 may include at

least one flute (not shown) along their main shafts and auto-centering drill points. The length of the proximal drill **174** may be about 35 mm or less on a drill having an overall length of 3 inches. The length of the distal drill **172** may be approximately one-half the length of the proximal drill **174**. The overall lengths of the distal side **173** may be equal to the overall length of the proximal side **175**, and these lengths may be independent of the lengths of the distal drill **172** and proximal drill **174**. The width of hex flats **182** may be about 1/4 inch, 3/8 inch or 1/2 inch. The face of hilt stops **176** and **177** may be approximately 60° and may include at least one flute (not shown) for cutting a chamber at the insertion point.

[0041] In addition to the treatment of hammer toe, the present invention is suitable for other applications, such as the treatment of a fractured bone in a hand, foot, or forearm. In particular, the segments of the fractured bone may be aligned and secured by a cortical bone pin described herein.

[0042] A second exemplary embodiment of the present invention will now be described with reference to FIGs. 9-11. As shown in FIG. 9, a pin according to a second embodiment includes barbs **101** and a hilt **102**.

[0043] As depicted in FIG. 10, the pin includes a proximal barb section **111** and a distal barb section **113** separated by the hilt **102**. The proximal barb section **111** may be twice the length of the distal barb section **113**. The width of the hilt **102** (indicated by **112** in FIG. 10) may be about 0.0 mm to about 5.0 mm. Each barb may have a barb angle **114**, being symmetrical to the center line of the pin, of for example approximately 15° to approximately 25°.

[0044] Details of the barbs will now be described with reference to FIG. 11. A barb crest **121** may be pointed or dull. A frustum connection **122** which connects each barb with an adjacent

barb may be sharp or rounded. A barb minor diameter **123** may be approximately 65% to approximately 75% of a barb major diameter **124**, and the barb major diameter **124** may be approximately 130% to approximately 150% of the barb minor diameter **123**. Half of the difference between the barb major diameter **124** and the barb minor diameter **123** yields the barb height **126**. A barb frustum angle **127** may be obtuse, creating a dull crest, or acute, yielding a sharp and pointed crest. The barb length **125** may be approximately 1.0 mm to approximately 3.0 mm and may vary from barb to barb on the same pin.

[0045] A third exemplary embodiment of the present invention will now be described with reference to FIGs. 12-13. In the first and second exemplary embodiments, the barbs are depicted as being frustoconical. The outer surface of each barb is continuous and each cross section taken perpendicular to the main axis of the pin may be defined by a circle. In the third exemplary embodiment, by contrast, various voids are created in each barb, resulting in spokes **131**.

[0046] A fourth exemplary embodiment of the present invention will now be described with reference to FIGs. 14-15. Similar to the third exemplary embodiment, various voids may be created in each barb, resulting in spokes **151**.

[0047] A fifth exemplary embodiment of the present invention will now be described with reference to FIGs. 16-18. Because the bone pin **11** according to this embodiment is similar to the bone pin **1** according to the first exemplary embodiment, only the differences between bone pin **1** and bone pin **11** will be described. Whereas bone pin **1** is depicted as having a substantially circular cross section across its length, bone pin **11** includes flattened side surfaces **13** as shown in FIGs. 16 and 17. These flattened side surfaces **13** may be located on opposite sides of the distal end of bone pin **11**. These flattened side surfaces **13** allow for the use of a tool **20**, shown

in FIG. 18, during insertion of the bone pin 11 into the proximal phalange. In one embodiment, the tool 20 is substantially cylindrical and substantially hollow. Flattened surfaces 21 may be formed on the inside of the tool and may be designed to engage with the flattened side surfaces 13 of the bone pin 11. According to one aspect, when the tool 20 is rotated, the bone pin 11 rotates during insertion into the proximal phalange.

[0048] Other than the specific differences noted above, the second through fifth exemplary embodiments may be similar to the first exemplary embodiment. Thus, for example, the pins according to the second through fifth exemplary embodiments may be made of the same material as the first exemplary embodiment, and may be cleaned, demineralized, and treated according to the same procedures described with reference to the first exemplary embodiment.

[0049] It will be apparent to those skilled in the art that various modifications and variations can be made in the pin of the present invention without departing from the spirit or scope of the invention. Thus, it is intended that the present invention cover the modifications and variations of this invention provided they come within the scope of the appended claims and their equivalents.

WHAT IS CLAIMED IS:

1. A pin, having an elongated body, comprising:
 - a proximal portion;
 - a distal portion;
 - barbs on the proximal portion; and
 - barbs on the distal portion, wherein
 - the barbs on the proximal portion have a profile such that, as the barbs proceed from a distal end to a proximal end, the barbs slope abruptly from a trough to a crest and slope gradually from a crest to a trough, and
 - the barbs on the distal portion have a profile such that, as the barbs proceeds from a distal end to a proximal end, the barbs slope gradually from a trough to a crest and slope abruptly from a crest to a trough.
2. The pin according to claim 1, further comprising a shoulder between the proximal portion and the distal portion, wherein
 - the shoulder has a diameter greater than the remainder of the pin.
3. The pin according to claim 2, further comprising flattened surfaces on opposite sides of the bone pin.
4. The pin according to claim 3, wherein the flattened surfaces are disposed on the distal portion of the pin.
5. The pin according to claim 1, wherein the pin comprises cortical bone.
6. The pin according to claim 5, wherein the cortical bone is human cortical bone.
7. The pin according to claim 5, wherein the cortical bone is animal cortical bone.

8. The pin according to claim 1, wherein the pin comprises resorbable materials.
9. The pin according to claim 1, wherein the pin comprises non-metallic, synthetic materials.
10. A method of using a pin according to claim 1.
11. A method of treating hammer toe comprising the step of inserting the bone pin according to claim 1 into a proximal phalange of a patient.
12. A method of treating a fractured bone or deformed bone or joint of a hand, foot, or forearm comprising the step of inserting the bone pin according to claim 1 into the fractured or deformed bone or a bone at the deformed joint.
13. A pin, having an elongated body, comprising:
 - a proximal portion;
 - a distal portion; and
 - a shoulder between the proximal portion and the distal portion, wherein the shoulder has a diameter greater than the remainder of the pin.
14. The pin according to claim 13, further comprising:
 - barbs on the proximal portion; and
 - barbs on the distal portion, wherein
 - the barbs on the proximal portion have a profile such that, as the barbs proceed from a distal end to a proximal end, the barbs slope abruptly from a trough to a crest and slope gradually from a crest to a trough, and
 - the barbs on the distal portion have a profile such that, as the barbs proceeds from a distal end to a proximal end, the barbs slope gradually from a trough to a crest and

slope abruptly from a crest to a trough.

15. The pin according to claim 14, further comprising flattened surfaces on opposite sides of the bone pin.

16. The pin according to claim 15, wherein the flattened surfaces are disposed on the distal portion of the pin.

17. The pin according to claim 13, wherein the pin comprises cortical bone.

18. The pin according to claim 17, wherein the cortical bone is human cortical bone.

19. The pin according to claim 17, wherein the cortical bone is animal cortical bone.

20. The pin according to claim 13, wherein the pin comprises resorbable materials.

21. The pin according to claim 13, wherein the pin comprises non-metallic, synthetic materials.

22. A method of using a pin according to claim 13.

23. A method of treating hammer toe comprising the step of inserting the bone pin according to claim 13 into a proximal phalange of a patient.

24. A method of treating a fractured bone or deformed bone or joint of a hand, foot, or forearm comprising the step of inserting the bone pin according to claim 13 into the fractured or deformed bone or a bone at the deformed joint.

1/8

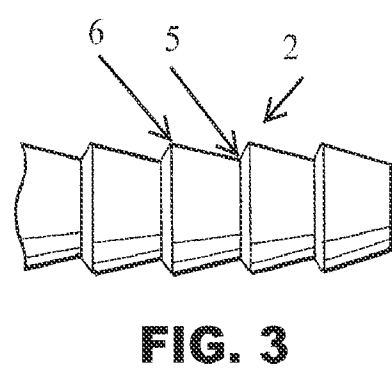
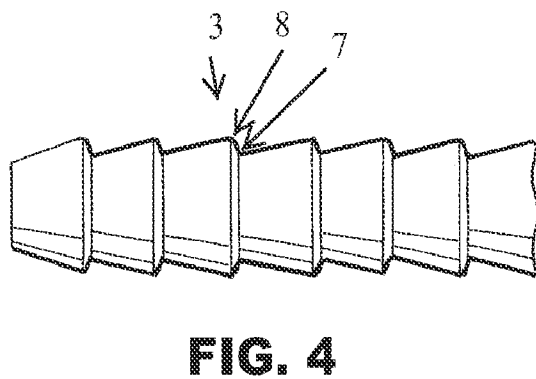
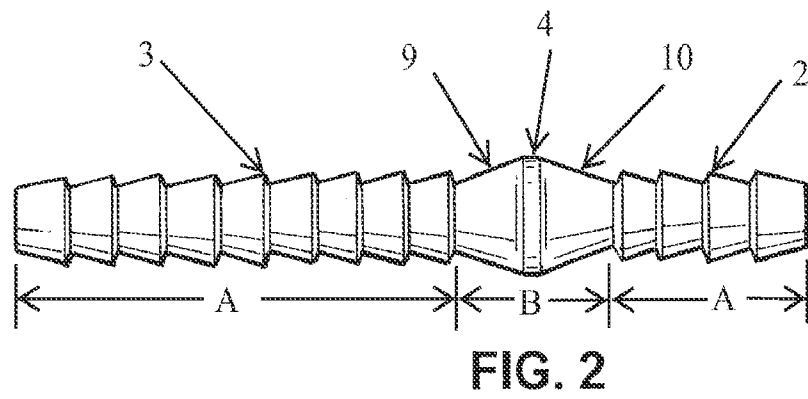
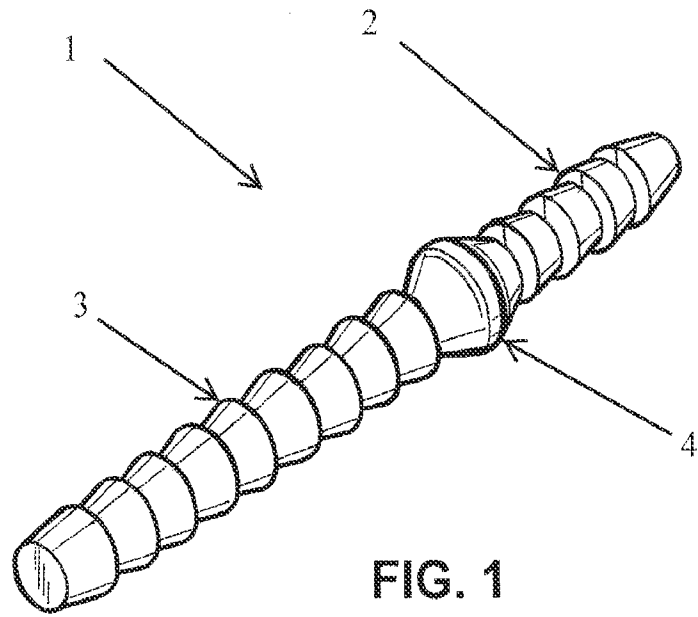

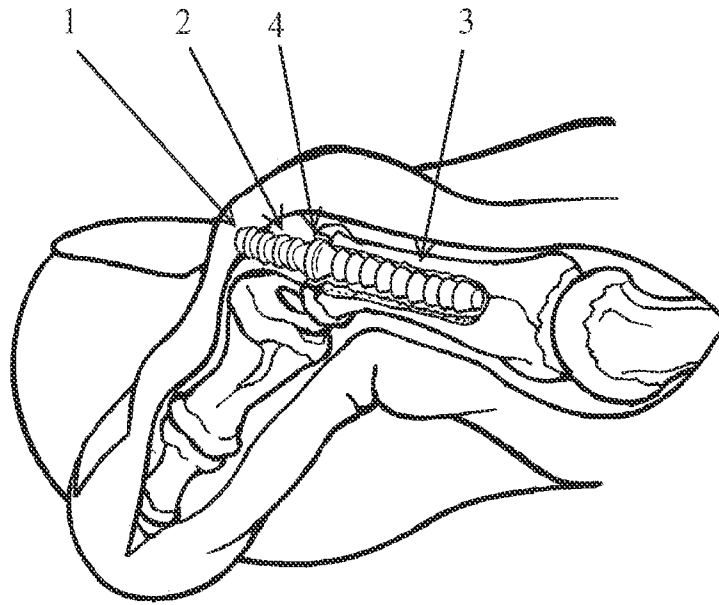

FIG. 5

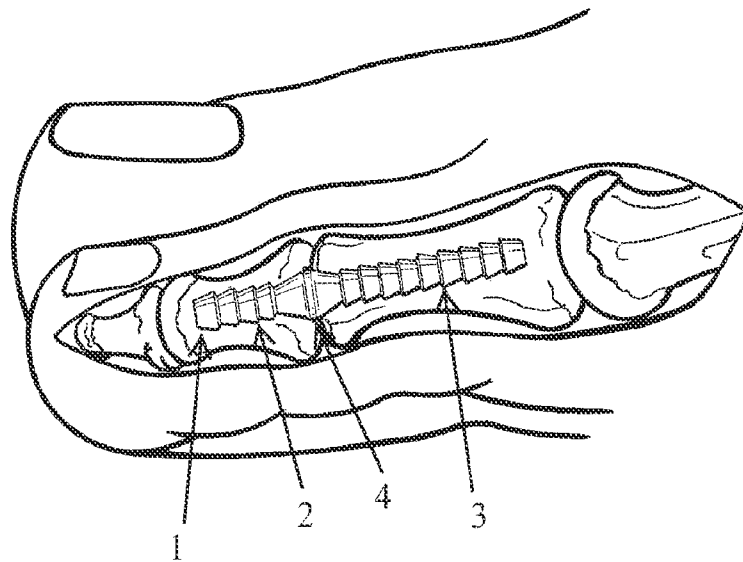

FIG. 6

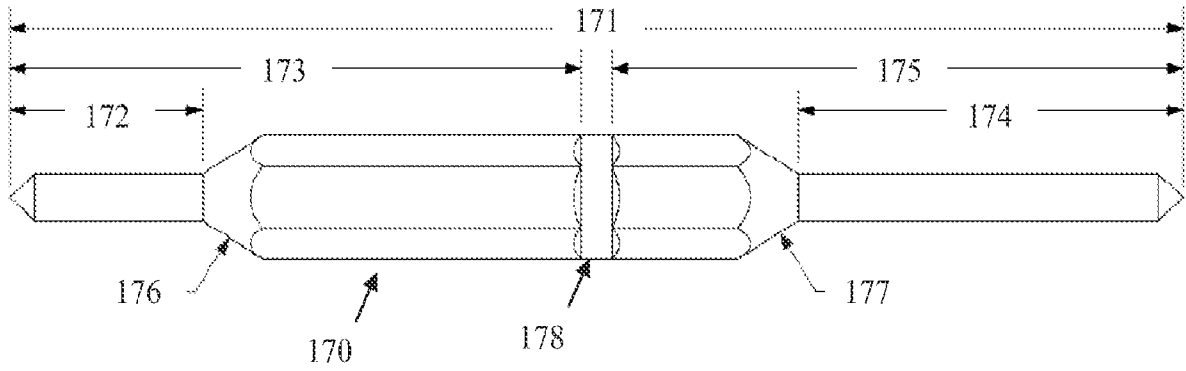

FIG. 7

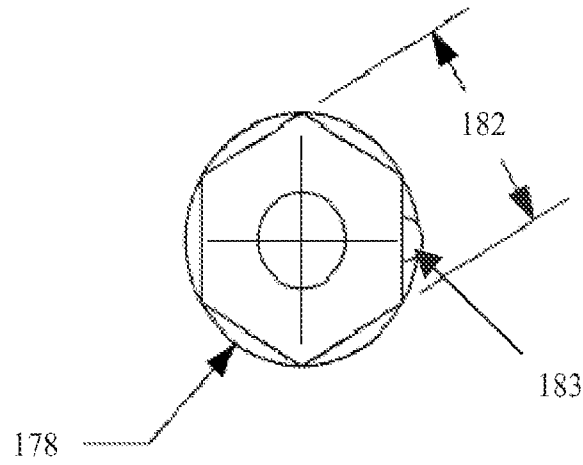

FIG. 8

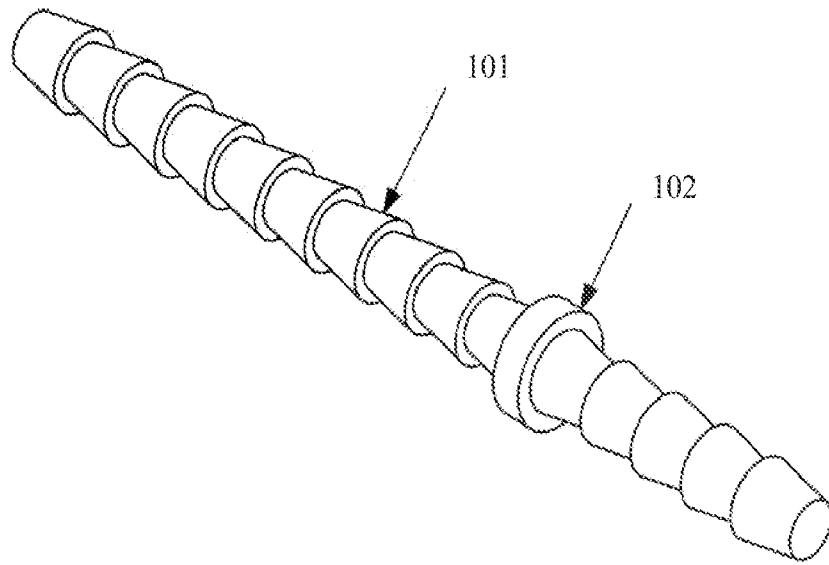

FIG. 9

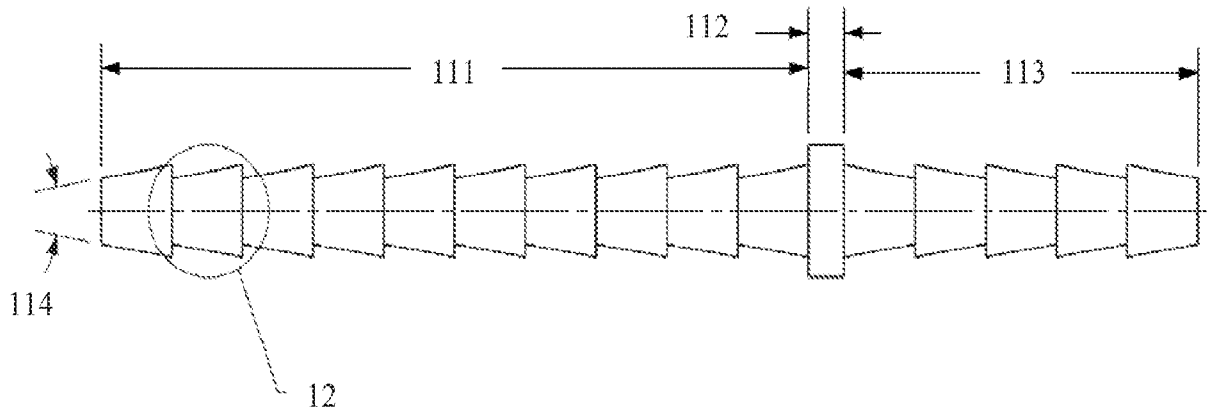

FIG. 10

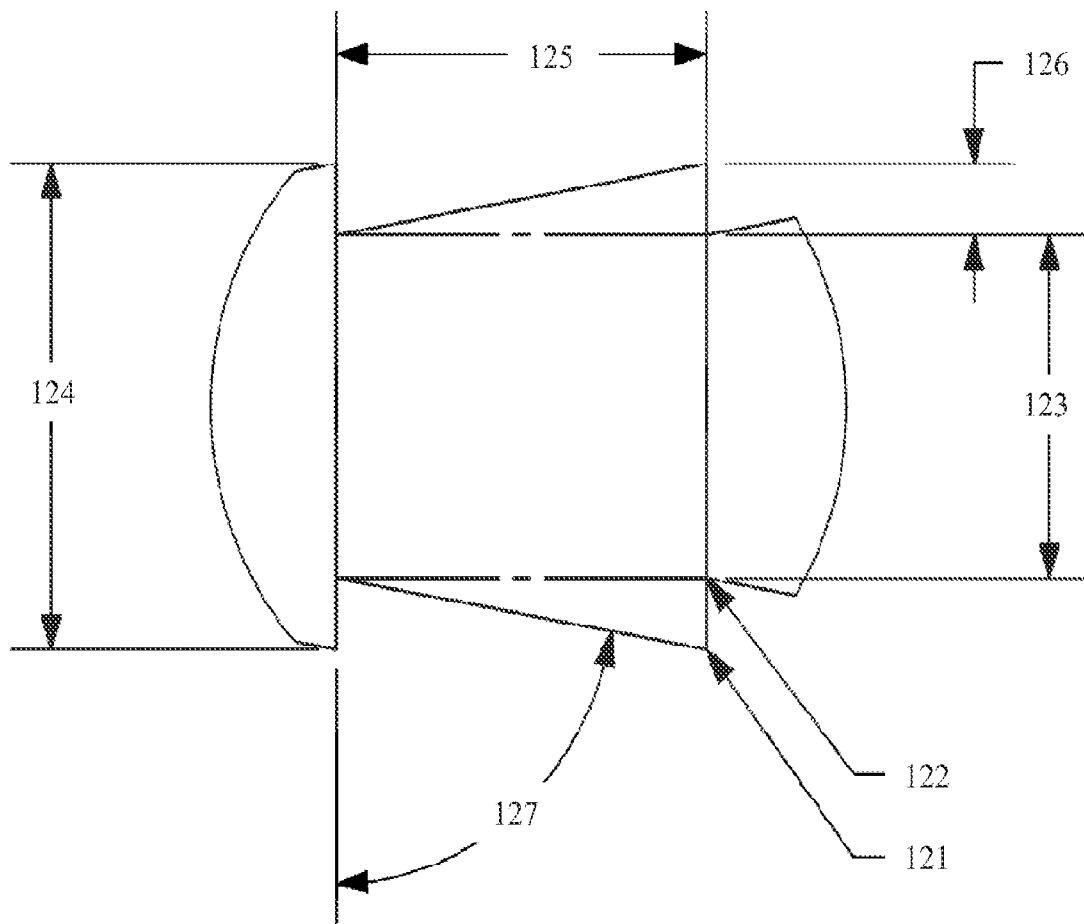

FIG. 11

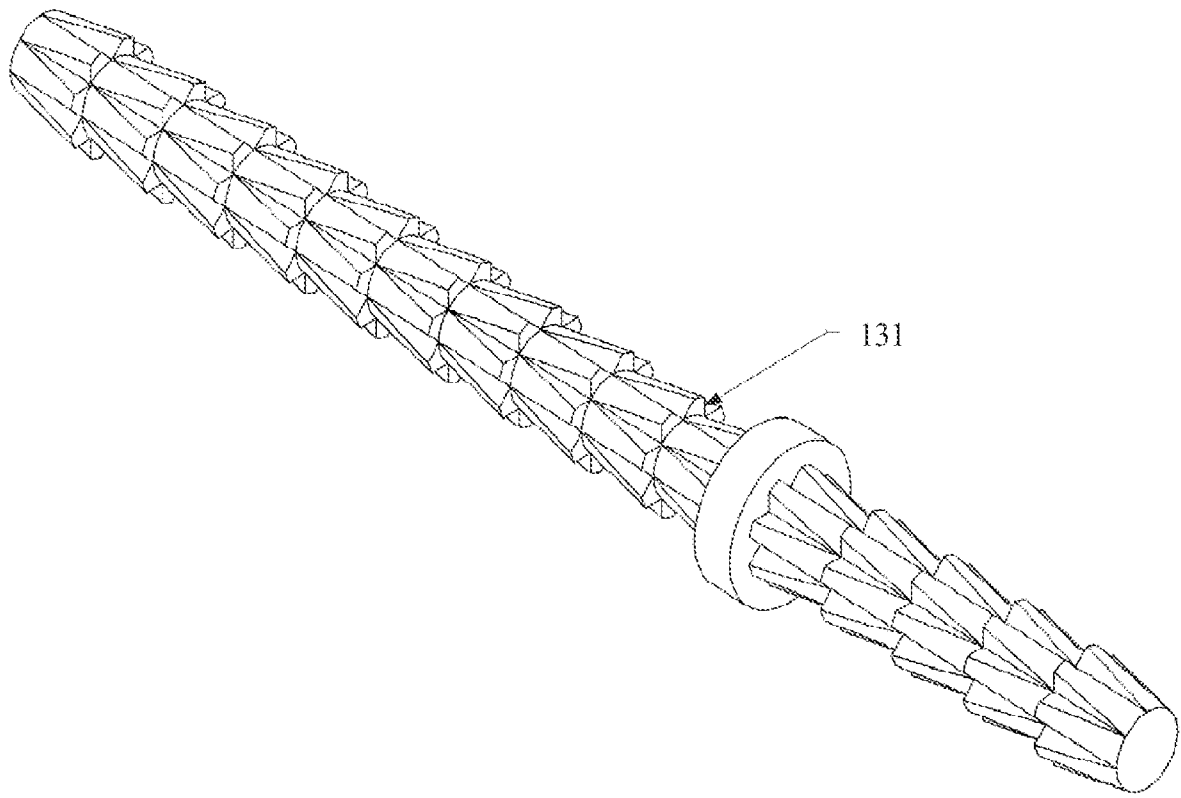

FIG. 12

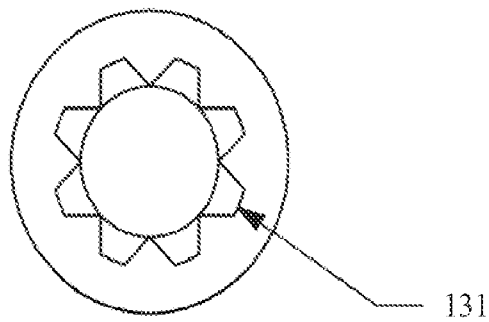

FIG. 13

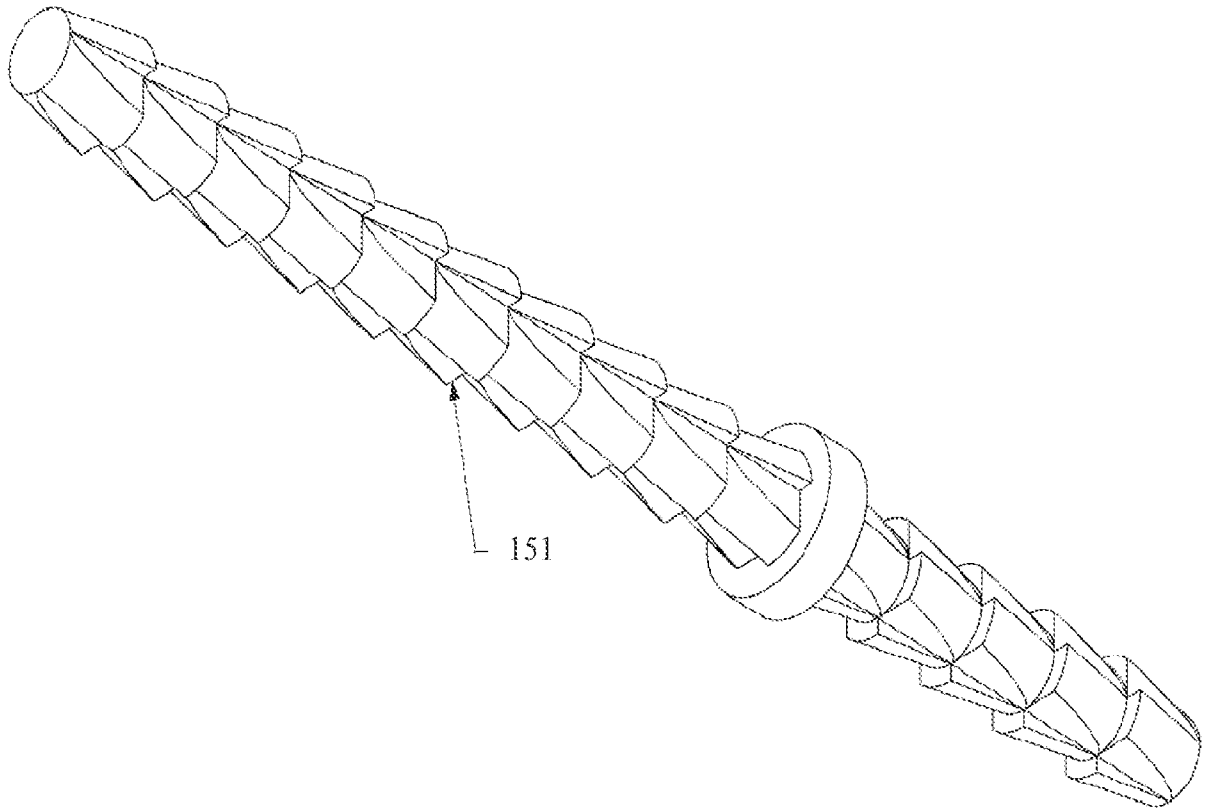

FIG. 14

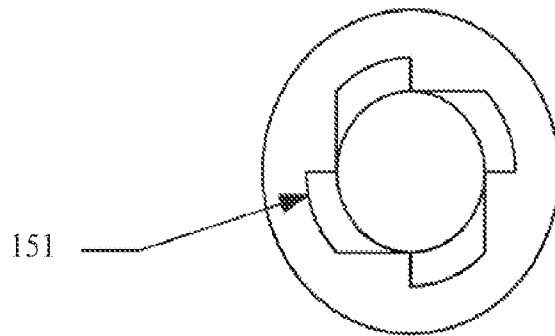
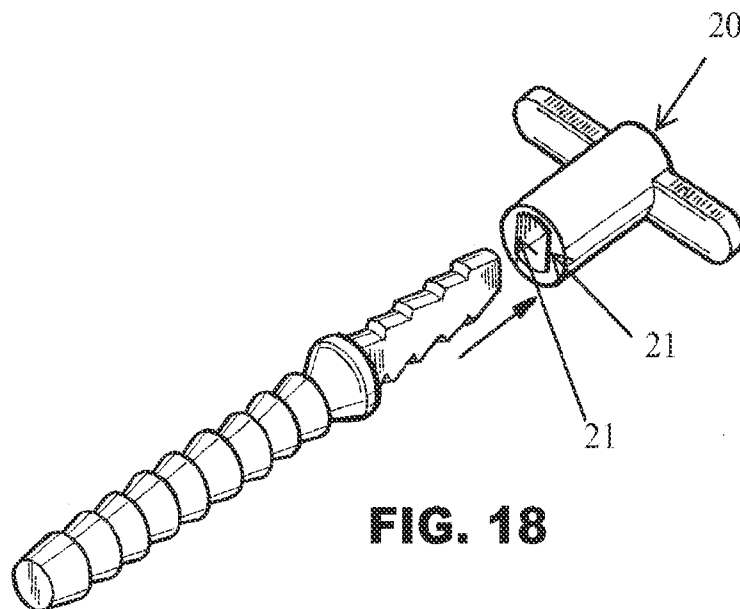
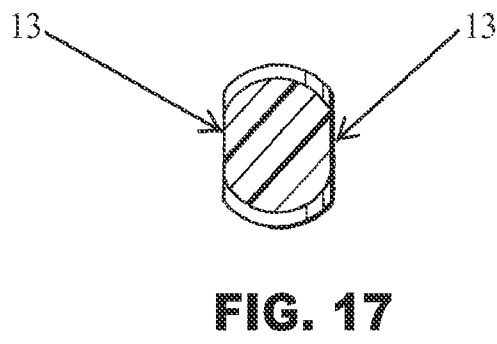
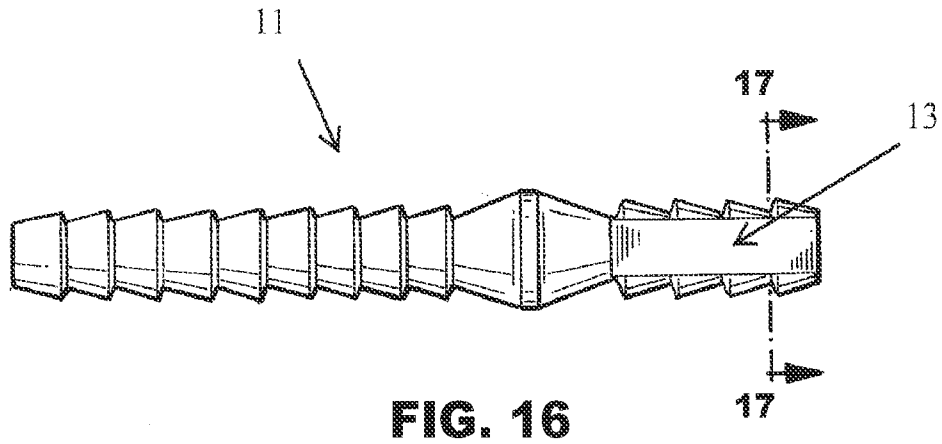

FIG. 15



PCT

INTERNATIONAL SEARCH REPORT

(PCT Article 18 and Rules 43 and 44)

Applicant's or agent's file reference 67949-5049WO	FOR FURTHER ACTION	see Form PCT/ISA/220 as well as, where applicable, item 5 below.
International application No. PCT/US2013/042170	International filing date (<i>day/month/year</i>) 22 May 2013	(Earliest) Priority Date (<i>day/month/year</i>) 22 May 2012
Applicant OPENET HEALTH		

This international search report has been prepared by this International Searching Authority and is transmitted to the applicant according to Article 18. A copy is being transmitted to the International Bureau.

This international search report consists of a total of 2 sheets.

It is also accompanied by a copy of each prior art document cited in this report.

1. Basis of the report

a. With regard to the **language**, the international search was carried out on the basis of:

the international application in the language in which it was filed.

a translation of the international application into _____ which is the language of a translation furnished for the purposes of international search (Rules 12.3(a) and 23.1(b)).

b. This international search report has been established taking into account the **rectification of an obvious mistake** authorized by or notified to this Authority under Rule 91 (Rule 43.6bis(a)).

c. With regard to any **nucleotide and/or amino acid sequence** disclosed in the international application, see Box No. I.

2. **Certain claims were found unsearchable** (see Box No. II).

3. **Unity of invention is lacking** (see Box No. III).

4. With regard to the **title**,

the text is approved as submitted by the applicant.

the text has been established by this Authority to read as follows:

5. With regard to the **abstract**,

the text is approved as submitted by the applicant.

the text has been established, according to Rule 38.2, by this Authority as it appears in Box No. IV. The applicant may, within one month from the date of mailing of this international search report, submit comments to this Authority.

6. With regard to the **drawings**,

a. the figure of the **drawings** to be published with the abstract is Figure No. 5

as suggested by the applicant.

as selected by this Authority, because the applicant failed to suggest a figure.

as selected by this Authority, because this figure better characterizes the invention.

b. none of the figures is to be published with the abstract.

A. CLASSIFICATION OF SUBJECT MATTER

IPC(8) - A61B 17/86 (2013.01)

USPC - 623/21.19

According to International Patent Classification (IPC) or to both national classification and IPC

B. FIELDS SEARCHED

Minimum documentation searched (classification system followed by classification symbols)

IPC(8) - A61B 17/56, 17/58, 17/86; A61F 2/42 (2013.01)

USPC - 606/60; 623/11.11, 18.11, 21.11, 21.15, 21.19

Documentation searched other than minimum documentation to the extent that such documents are included in the fields searched

CPC - A61B 17/7291; A61F 2/4225, 2002/30622, 2002/3085 (2013.01)

Electronic data base consulted during the international search (name of data base and, where practicable, search terms used)

PatBase, Google Patents

C. DOCUMENTS CONSIDERED TO BE RELEVANT

Category*	Citation of document, with indication, where appropriate, of the relevant passages	Relevant to claim No.
X	US 2011/0301652 A1 (REED et al) 08 December 2011 (08.12.2011) entire document	1-2, 10-14, 22-24
Y		3-9, 15-21
Y	US 2011/0082508 A1 (REED) 07 April 2011 (07.04.2011) entire document	3-4, 15-16
Y	US 2002/0022843 A1 (MICHELSON) 21 February 2002 (21.02.2002) entire document	5-9, 17-21

Further documents are listed in the continuation of Box C.

* Special categories of cited documents:

"A" document defining the general state of the art which is not considered to be of particular relevance

"E" earlier application or patent but published on or after the international filing date

"L" document which may throw doubts on priority claim(s) or which is cited to establish the publication date of another citation or other special reason (as specified)

"O" document referring to an oral disclosure, use, exhibition or other means

"P" document published prior to the international filing date but later than the priority date claimed

"T" later document published after the international filing date or priority date and not in conflict with the application but cited to understand the principle or theory underlying the invention

"X" document of particular relevance; the claimed invention cannot be considered novel or cannot be considered to involve an inventive step when the document is taken alone

"Y" document of particular relevance; the claimed invention cannot be considered to involve an inventive step when the document is combined with one or more other such documents, such combination being obvious to a person skilled in the art

"&" document member of the same patent family

Date of the actual completion of the international search.

05 August 2013

Date of mailing of the international search report

15 AUG 2013

Name and mailing address of the ISA/US

Mail Stop PCT, Attn: ISA/US, Commissioner for Patents
P.O. Box 1450, Alexandria, Virginia 22313-1450

Facsimile No. 571-273-3201

Authorized officer:

Blaine R. Copenheaver

PCT Helpdesk: 571-272-4300

PCT OSP: 571-272-7774