

April 7, 1931.

H. BOKELMANN ET AL

1,799,881

MARKING MEANS FOR ELECTRIC CONDUITS

Filed Feb. 24, 1927

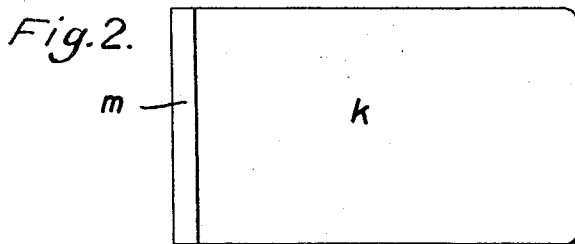
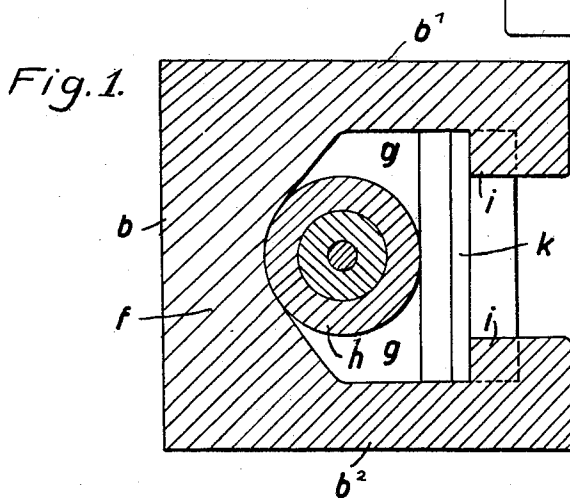
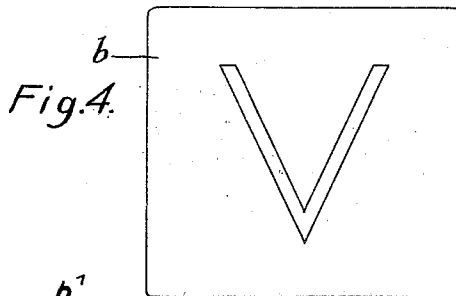

Inventors:
Heinrich Bokelmann & Hans
Gastrow
per.
Dr. Adolf H. Krummholz
Attorney

UNITED STATES PATENT OFFICE

HEINRICH BOKELMANN, OF BERLIN, AND HANS GASTROW, OF BERLIN-ZEHLENDORF,
GERMANY

MARKING MEANS FOR ELECTRIC CONDUITS

Application filed February 24, 1927, Serial No. 170,675, and in Germany February 26, 1926.

This invention has reference to means for the mounting of signs or writing-carrying shields or the like to electric cables and insulated electric conductors generally, and it is intended to provide a more convenient, durable and easier way of securing such signs or plates or the like bearing certain designations to cables and conductors than heretofore known from the previous art. The well known signs for electric conductors are mounted only with difficulty, they are not rigidly retained in position, or, in case of their being secured to the terminal connecting means, they are liable to become readily detached and to drop off upon the disconnection of the respective branches.

These inconveniences are avoided in the subject matter of our invention which provides a sign and means of securing the same to be mounted in a simple and easy manner, and it presents the additional advantage that by the use of an intermediate closing member the clamping attachment to the cable or conductor is intensified and secured. In its broad aspects the invention comprises a clasp or a substantially U-shaped forked or frame-like member and carrying the sign or the plate bearing the designation which is attached in such a manner that it will serve as a closing means for the two free ends of the clasp or frame. In a preferred form of construction of the invention the sign, plate or the like is provided with side legs at an angle to the body part of the devices, and comprising means, such as interiorly projecting shouldered or enlargements adapted for the reception of a closing or securing member of sheet metal or equivalent material which displaceably and detachably covers up the space between said side legs and which by its springiness or the springiness of a portion thereof will yieldingly secure the cable or the like in its proper position without injuring the coating thereof. The entire marking device may be easily and quickly assembled and disassembled and among other valuable features it presents the advantage of possessing several outer faces for the reception of several designations, writings or the like.

In further pursuance of this invention, it is another characteristic and advantageous feature that the multi-faced frame or the like for the mounting of the designation consists of colored, thermoplastic, compressible material, such as so-called Trolit or the like.

With a view of acting as a stop when slidingly pushing the sign or the like onto the piece of sheet metal referred to, this sheet which serves as a closing means may be preferably turned over at one side. As another important feature it may be mentioned that in the case of rather elongated signs or inscription-bearing plates or the like spring acting closures of sheet metal may be slidingly introduced from both sides.

The invention will be described more in detail with reference to the accompanying drawing showing by way of exemplification two embodiments of the principles thereof.

Figure 1 is a cross sectional view of the device with the cable inserted therein; Figure 2 is a plan view of the sheet metal closing plate, Figure 3 is a side view of the said closing plate, and Figure 4 shows diagrammatically in plan view the outer identification surface adapted for the reception of the marks, signs and the like.

The body part f of the U-shaped or yoke like member the back surface of which is designated b presents several exposed surfaces, three indicating surfaces being shown herein. The two other surfaces thereof are respectively designated b^1 and b^2 . The body f carrying the signs or the like is provided with a recess g at its rear side in which the insulated conductor h is inserted. The jaws of the recessed part g are shaped so as to carry flanges, tabs, stops or the like i . At the rear of these flanges, tabs, stops or the like i the closing sheet metal piece k is slidingly introduced in the direction of the insulated conductor or cable. The plate k carries a turned over portion m at its upper side adapted to limit the movement of the sign or inscription bearing plate by abutting against the stops i . In order to force said sign or the like firmly against the conductor, cable or the like, the middle portion of the closing sheet metal plate k is curved outwards at n , so as to be adapted

to spring-actingly place itself with its convex part against the conductor *h*, and to secure the sign in position against the same.

The signs or inscription bearing means in accordance with this construction are particularly suitable for conductors of smaller cross section. The length of the inscription bearing means in the direction of the conductor is not limited, so that the writing or inscription in the longitudinal direction may be of any length desired. There is the further advantage that by providing for the utilization of several surfaces of the inscription bearing means a more extensive inscription and designation than heretofore has become possible without requiring an undue amount of space. In the case of particularly long signs or inscription means closing sheet metal plates are introduced from both sides. The invention is not limited to the specific embodiments herein shown and described, but it may be modified to suit existing conditions and the convenience of the user without deviating from the spirit of the invention, as expressed in the accompanying claims.

We claim:—

1. A marking device for an electric conductor, comprising a substantially U-shaped member adapted for straddling engagement with part of the periphery of the conductor, inwardly and confrontingly projecting tabs on the legs of said U-shaped member, substantially plate-shaped closing means, slidingly supported on said tabs inside of said legs, and a straight-edged, substantially rib-shaped, transversely disposed inwardly projecting portion on said closing means, adapted for substantially tangential, crosswise engagement with said conductor.

2. A marking device for an electric conductor, comprising a substantially yoke-shaped two-legged member, adapted for substantially tangential engagement with said conductor intermediate its legs, substantially flat, plate-shaped closing means, slidingly disposed inside of said legs and in engagement therewith and in the longitudinal direction of the two-legged member and of the conductor, and a transversely convexed, straight-edged portion on said closing means, adapted for substantially tangential, supporting engagement with the conductor.

3. A marking device for an electric conductor, comprising a substantially U-shaped, seating member for the conductor, and spacedly parallel legs on said member, supporting tabs inwardly and confrontingly disposed at the extremities of said legs, and substantially plate-shaped closing means, slidingly supported on said tabs between the legs, and an outwardly projecting, securing portion on said closing means, facing the depression between the legs of the seating member and transversely thereof, and a straight-edged contacting part on the securing portion,

adapted for tangential engagement with the conductor.

4. A marking device for an electric conductor, comprising a substantially U-shaped member, astride of the conductor and engaging therewith intermediate its legs and spaced from said legs, inwardly and confrontingly projecting tabs on the legs, and a substantially flat, slidingly disposed closing member in parallelism with the conductor and resting on the tabs, and a transversely disposed projecting portion on said closing member, convexed in the direction of the conductor and engaging therewith, and a turned-over terminal portion on the closing member, substantially parallel with the said projecting portion.

HEINRICH BOKELMANN.
HANS GASTROW.