



- (51) International Patent Classification:
B60C 23/00 (2006.01) B60C 23/20 (2006.01)
B60C 23/04 (2006.01)
- (21) International Application Number:
PCT/MY2015/000087
- (22) International Filing Date:
30 October 2015 (30.10.2015)
- (25) Filing Language: English
- (26) Publication Language: English
- (30) Priority Data:
PI 2014703332 7 November 2014 (07.11.2014) MY
- (71) Applicant: SALUTICA ALLIED SOLUTIONS SDN. BHD. [MY/MY]; No. 3, Jalan Zarib 6, Kawasan Peridunstrian Zarib, 31500 Lahat, Ipoh, Perak (MY).
- (72) Inventor: PETER HENG SIE JENG; c/o Salutica Allied Solutions Sdn. Bhd., No. 3, Jalan Zarib 6, Kawasan Peridunstrian Zarib, 31500 Lahat, Ipoh, Perak (MY).

(74) Agent: TAN SI SU; c/o QO Patent Sdn Bhd, L5-07, Level 5, Wisma BU8, No. 11, Lebuhr Bandar Utama, Bandar Utama, 47800 Petaling Jaya, Selangor (MY).

(81) Designated States (unless otherwise indicated, for every kind of national protection available): AE, AG, AL, AM, AO, AT, AU, AZ, BA, BB, BG, BH, BN, BR, BW, BY, BZ, CA, CH, CL, CN, CO, CR, CU, CZ, DE, DK, DM, DO, DZ, EC, EE, EG, ES, FI, GB, GD, GE, GH, GM, GT, HN, HR, HU, ID, IL, IN, IR, IS, JP, KE, KG, KN, KP, KR, KZ, LA, LC, LK, LR, LS, LU, LY, MA, MD, ME, MG, MK, MN, MW, MX, MY, MZ, NA, NG, NI, NO, NZ, OM, PA, PE, PG, PH, PL, PT, QA, RO, RS, RU, RW, SA, SC, SD, SE, SG, SK, SL, SM, ST, SV, SY, TH, TJ, TM, TN, TR, TT, TZ, UA, UG, US, UZ, VC, VN, ZA, ZM, ZW.

(84) Designated States (unless otherwise indicated, for every kind of regional protection available): ARIPO (BW, GH, GM, KE, LR, LS, MW, MZ, NA, RW, SD, SL, ST, SZ, TZ, UG, ZM, ZW), Eurasian (AM, AZ, BY, KG, KZ, RU, TJ, TM), European (AL, AT, BE, BG, CH, CY, CZ, DE, DK, EE, ES, FI, FR, GB, GR, HR, HU, IE, IS, IT, LT, LU, LV, MC, MK, MT, NL, NO, PL, PT, RO, RS, SE, SI, SK,

[Continued on next page]

(54) Title: WIRELESS TIRE MONITORING DEVICE

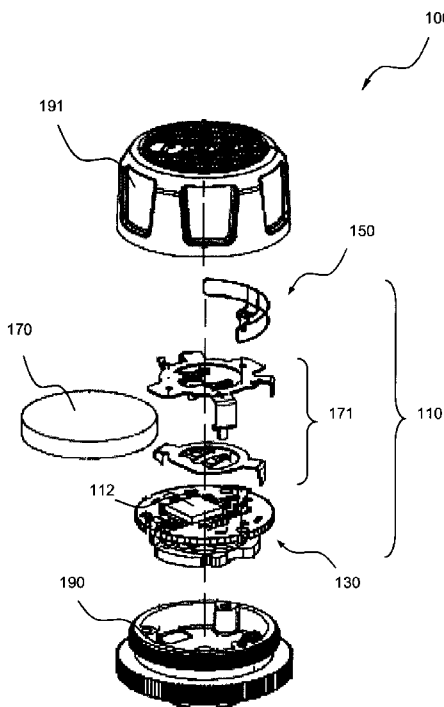
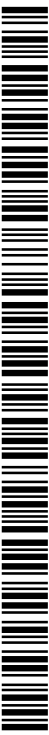

FIG. 1a

(57) Abstract: The present invention relates to a wireless tire monitoring device for a vehicle. Accordingly, the wireless tire monitoring device (100) includes: a) a tire pressure/temperature signal transmitting device (110); b) at least one sensor unit (130) for measuring or detecting at least one parameter relating to the conditions of the tire (200); c) an antenna (150) for transmitting signal corresponding to the tire conditions; wherein the wireless tire monitoring device (100) is detachably mounted to a valve stem (210) of the tire (200) and being served as a cap for the valve stem (210); wherein the antenna (150) includes at least one curvature strip (151) configured at same axis (Z - Z) with the valve stem (210) so that it centre axis aligns with the valve stem (210) of the tire (200); and wherein the antenna (150) and valve stem (210) share a common axis (X - X) of a tire wheel (230) and adapted to be revolved about the common axis (X - X) of the tire wheel (230).



SM, TR), OAPI (BF, BJ, CF, CG, CI, CM, GA, GN, GQ, GW, KM, ML, MR, NE, SN, TD, TG). **Published:**

Declarations under Rule 4.17:

— as to the identity of the inventor (Rule 4.17(i))

— with international search report (Art. 21(3))

— before the expiration of the time limit for amending the claims and to be republished in the event of receipt of amendments (Rule 48.2(h))

WIRELESS TIRE MONITORING DEVICE

FIELD OF INVENTION

5 The present invention relates generally to a wireless tire monitoring device for vehicle, and more particularly to a tire pressure / temperature signal transmitting device with wireless interface.

BACKGROUND OF INVENTION

10

Arriving at the destination conveniently and safely is significantly important for the consumer group who own automobiles. Various types of automobiles or vehicles have become prerequisite traffic means or transporting equipment in the modern society. As a result, people are paying more and more attention to the safety in driving a vehicle.

15

One of the factors that affects the safety of driving is the functionality and proper operation of vehicle's components (such as braking system, tires, ignition system), which is the most important link. In terms of tires, factors that affect the safety include tire pressure and tire temperature in addition to the grooves of the tire surface. As such, the
20 tire pressure and/or temperature detection are crucial for a vehicle.

20

For example, if the tire pressure is 25% lower than the normally required tire pressure over a long period of time, the tire tends to have a dramatic temperature rise that may result in a blowout when the vehicle is moving at a high speed. If the tire pressure is too
25 high or insufficient, it will cause damage to the tires.

Accordingly, should the tire pressure be 25% higher than a standard tire pressure value; the usable life of the tire will be shortened by 15% - 20%; and when the tire pressure is 25% lower than the standard value, the usable life of tire shortens by 30%. Properly inflated tires not only have enhanced performance and safety in use, but also save more
5 fuel and have prolonged tire life.

However, according to statistics, 20% of the currently being used vehicles have insufficiently inflated tires. Moreover, tire temperatures also have important influence on safe driving. The higher the tire temperature is, the lower the tire strength is. That is, tires
10 with high tire temperature are more easily deformed. Moreover, the tire wearing increases by 2% when the tire temperature rises by 1° C.

Only when the tire pressure is at the right amount can the tire achieve its optimal performance. When the tire pressure is too high, the fraction of the tire when rolling
15 becomes small. However, because the contact area between the tire and the ground is shortened, the middle of the tire is worn out quickly. Because the tire's surface tension expands, it creates damages as well as cracks. On the other hand, when the tire pressure is insufficient, the fraction of the tire when rolling becomes great, gas consumption increases, and the wear and tear on both sides of the tire increases relatively. As such, it
20 increases the tire temperature and causes surface or ply of the tire to exfoliate easily. When the tire temperature is overheated, blow out may occur.

To ensure safe driving, various types of tire pressure monitoring systems have been developed. Some prior arts teach the incorporation of sensors, either to the tire proper or
25 in proximity thereof, for measuring an operational parameter of the tire. Once the parameter is measured, it is transmitted to a terminal at a remote location, such as for example a maintenance facility, or to a monitor fixedly mounted to the vehicle.

A number of prior art devices have attempted to solve the problem of improperly inflated vehicle tires. Typically, these devices tend to monitor tire parameters, such as temperature and pressure, and provide an indication to the vehicle operator if any of the vehicle tires are improperly inflated or a potential safety hazard exists due to severe under inflation. Many of the prior art devices provide a remote sensor within each of the tires in addition to a transmitter for transmitting a signal to a centrally located receiving unit. However, some prior art device has succumbed to at least one of the many varied challenges imposed upon a sensor subjected to the incredibly harsh operating environment of a vehicle tire.

A typical vehicle operating environment is not particularly amenable to the transmission and reception of digital or analog signals. Since some of the transmitter is often located entirely within a vehicle tire, powered by a battery separate from the vehicle battery, the receiver must be especially sensitive to the detection of relatively weak signals present in an electrically noisy milieu. Furthermore, the various electrically conductive components found on a typical vehicle may facilitate electrical communication but tend to hinder radio wave transmissions.

Another significant problem associated with the transmitter disposed upon or within the vehicle tire is that rotation of a transmitting antenna induces a "Doppler frequency shift" in the transmitted signal if the antenna is not oriented with its centre of mass along the axis of rotation of the vehicle tire. Thus, systems which utilize a valve stem of the tire as the transmitting antenna must provide complex detection circuitry to compensate for the Doppler shift. Alternatively, such systems may dramatically increase the redundancy of transmissions since much of the information will be filtered out as noise. Moreover, high rotational speed or revolution of the tire wheel may lead to inconsistency of signal

transmission. Thus, inconsistent transmission and relatively weak signals may lead to loss of information or false information with regard to the tire pressure / temperature conditions of the vehicle.

5 In view of these and other shortcomings, it is desirous to provide a wireless tire monitoring device adapted to be detachably mounted to a valve stem of the vehicle tire, such that it provides a simple and effective device that lending in both to economy of manufacture and simplicity / convenient of use, and yet resists to any unfavourable weather conditions, dirt or debris contamination, while enables to functioning reliably
10 under conditions adverse to wireless transmissions, such as frequency shift induced by rotation of the wheel or Doppler shift. The present invention also facilitates prolonged periods of power consumption, and yet substantially reduced in assembly and maintenance costs. The wireless tire monitoring device of the present invention and its combination of elements thereof will be described and/or exemplified in the detailed
15 description.

SUMMARY OF THE INVENTION

The present invention relates to a wireless tire monitoring device for a vehicle. Accordingly, the wireless tire monitoring device includes: a) a tire pressure / temperature
5 signal transmitting device; b) at least one sensor unit for measuring or detecting at least one parameter relating to the conditions of the tire; c) an antenna for transmitting signal corresponding to the tire conditions; wherein the wireless tire monitoring device is detachably mounted to a valve stem of the tire and being served as a cap for the valve stem; wherein the antenna includes at least one curvature strip configured at same axis
10 (Z – Z) with the valve stem so that its centre axis aligns with the valve stem of the tire; and wherein the antenna and valve stem share a common axis (X – X) of a tire wheel and adapted to be revolved about the common axis (X – X) of the tire wheel.

The tire pressure / temperature signal transmitting device is further equipped with a
15 battery holder to accommodate a battery. By way of example but not by way of limitation, the at least one curvature strip of the antenna is a fully, substantially or semi-circular strip adapted to be configured along the circumference of the battery holder.

In the preferred embodiment of the present invention, the antenna, which revolves about
20 the common axis (X – X) of the tire wheel, is being oriented so that its centre axis of the curvature strip lies along with the axis (Z – Z) of the valve stem; and such configuration enables to avoid any inducing of Doppler frequency shift to transmitted signal. The valve stem, which tiltably extends from the tire in nature, enables a radially transmission of the signals from the curvature strip of the antenna to be channelled or directed to the vehicle
25 body. Accordingly, the radially transmission signals of the curvature strip enables to eliminate any inconsistency or weak signals transmission, thus any loss of information or false information relating to the conditions of the tire can be eliminated.

The tire pressure / temperature signal transmitting device is also equipped with a micro-controller. Accordingly, the micro-controller serves to process all related information received from the sensor unit and transmits the information to other associated units in a
5 tire pressure monitoring system (TPMS) via the antenna.

In accordance with the preferred exemplary of the present invention, the antenna is preferably electronically connected to the Bluetooth chip for Bluetooth pairing, wireless communication or encryption, and for transmitting wireless signal relating to the tire
10 conditions, in between the tire pressure / temperature signal transmitting device and the other associated units in tire pressure monitoring system (TPMS). It will be appreciated that the antenna is being controlled by the micro-controller such that it facilitates prolonged periods of power consumption to continuously generate an ultra-low power consumption Bluetooth wave signal to extend the useful life of the battery.

15

The present invention consists of several novel features and a combination of parts hereinafter fully described and illustrated in the accompanying description and drawings, it being understood that various changes in the details may be made without departing from the scope of the invention or sacrificing any of the advantages of the present
20 invention.

BRIEF DESCRIPTION OF THE DRAWINGS

The present invention will be fully understood from the detailed description given herein below and the accompanying drawings which are given by way of illustration only, and
5 thus are not limitative of the present invention, wherein:

FIG. 1a is an exploded view in perspective of a wireless tire monitoring device, which is adapted to be detachably mounted to a valve stem of the vehicle tire in accordance with preferred exemplary of the present invention;

10

FIG. 1b is a partly assembly top and side elevation view of the wireless tire monitoring device in accordance with preferred exemplary embodiment of the present invention;

FIG. 1c is a partly assembly view in perspective of the wireless tire monitoring device of

15
FIG. 1b according to preferred exemplary of the present invention;

FIG. 2a is an enlarged top and side elevation view of a sensor antenna of the wireless tire monitoring device in accordance with preferred exemplary of the present invention;

20
FIG. 2b is an enlarged view in perspective of the sensor antennal of FIG. 1b according to preferred exemplary of the present invention.

FIG. 3 illustrates the wireless tire monitoring device being installed at each valve stem of the tire according to preferred exemplary of the present invention.

25

DETAILED DESCRIPTION OF THE PREFERRED EMBODIMENTS

The present invention relates to a wireless tire monitoring device, and more particularly to a tire pressure / temperature signal transmitting device which is capable of wirelessly
5 interfaced with a tire pressure monitoring system (TPMS). Hereinafter, this specification will describe the present invention according to the preferred embodiments of the present invention. However, it is to be understood that limiting the description to the preferred exemplary embodiments of the invention is merely to facilitate discussion of the present invention and it is envisioned that those skilled in the art may devise various modifications
10 and equivalents without departing from the scope of the appended claims.

The wireless tire monitoring device according to the preferred mode of carrying out the present invention will now be described in accordance to the accompanying drawings
FIGS. 1a to 3, either individually or in any combination thereof.

15

With reference to FIGS. 1a to 1c, the wireless tire monitoring device (100) in accordance with preferred exemplary of the present invention generally includes a tire pressure / temperature signal transmitting device (110), a sensor unit (130), and an antenna (150) for transmitting signal corresponding to the tire conditions.

20

Accordingly, the tire pressure / temperature signal transmitting device (110) includes at least one sensor unit (130) for measuring or detecting at least one parameter, such as for example, but not limited to, tire pressure, temperature, wheel speed, acceleration, distance information or any other preferred parameters relating to the conditions of the
25 tire (200). It should be noted that the tire pressure / temperature signal transmitting device (110) is preferably disposed at each valve stem (210) of the tire (200), such that it

enables to provide desired readings, information or parameters relating to the conditions of the tire (200).

Accordingly, the wireless tire monitoring device (100) is preferably detachably mounted to
5 the valve stem (210) of the tire (200) and being served as a cap for the valve stem (210).
Said wireless tire monitoring device (100) is preferably powered by a battery (170). By
way of example but by way of limitation, on top of the sensor unit (130) is equipped with a
battery holder (171) to accommodate the battery (170).

10 The tire pressure / temperature signal transmitting device (110) may also provide with a
micro-controller (112). Preferably, the micro-controller (112) is electronically connected to
the sensor unit (130), such that to enable the sensor unit (130) to continuously detect the
desired parameters relating to the conditions of the tire (200), and transmits the detected
information to the micro-controller (112). Accordingly, the micro-controller (112) serves to
15 process all related information received from the sensor unit (130) and transmits the
information to other associated units (not shown) in a tire pressure monitoring system
(TPMS) via the antenna (150).

The tire pressure / temperature signal transmitting device (110) may further include a
20 Bluetooth chip with pairing capability to enable the tire pressure / temperature signal
transmitting device (110) to be communicated or paired with other associated units in the
tire pressure monitoring system (TPMS).

In the preferred exemplary, the antenna (150) is preferably electronically connected to the
25 Bluetooth chip for Bluetooth pairing, wireless communication or encryption, and for
transmitting wireless signal relating to the tire conditions, in between the tire pressure /
temperature signal transmitting device (110) and the other associated units in tire

pressure monitoring system (TPMS). It should be noted that the antenna (150) is being controlled by the micro-controller (112) such that it facilitates prolonged periods of power consumption to continuously generate an ultra-low power consumption Bluetooth wave signal (300) to extend the useful life of the battery (170).

5

It should be noted that the antenna (150) includes at least one curvature strip (151) (see FIGS. 2a and 2b) adapted to be configured around the circumference of the battery (170). By way of example but not by way of limitation, the curvature strip (151) may be a fully, substantially or semi-circular strip adapted to be configured along the circumference of
10 the battery holder (171).

It should also be noted that said curvature strip (151) of the antenna (150) is preferably configured at same axis (Z – Z) with the valve stem (210) so that its centre axis aligns with the valve stem (210) of the tire (200) (refer to FIG. 3). As such, the antenna (150) and
15 valve stem (210) share a common axis (X – X) of a tire wheel (230) and adapted to be revolved about the common axis (X – X) of the tire wheel (230) when the vehicle (400) displaces.

Accordingly, in order to avoid inducing a Doppler frequency shift to the transmitted signal,
20 the antenna (150) of the tire pressure / temperature signal transmitting device (110), which revolves about the common axis (X – X) of the tire wheel (230), is being oriented so that its centre axis of the curvature strip (151) lies along with the axis (Z – Z) of the valve stem (210). Because the valve stem (210), which tiltably extends from the tire (200) in nature, a radially transmission of the signals from the curvature strip (151) of the antenna
25 (150) are able to be channelled or directed to the vehicle body. As such, the curvature strip (151) of the antenna (150) enables to eliminate any inconsistency or weak signals

transmission. Thus loss of information or false information relating to the conditions of the tire (200) may also be eliminated.

It will be appreciated that the tire pressure / temperature signal transmitting device (110)
5 is preferably enclosed by a rigid cover (191). Accordingly, the rigid cover (191) is securely mounted to a receptacle (190) in an airtight and/or watertight engagement, such that it is capable to resist any unfavourable weather conditions, dirt or debris contamination, without affecting wireless transmission performance of the wireless tire monitoring device (100).

10

It should be noted that the arrangements or configurations of various units, components and/or elements used to carry out the above-mentioned embodiments are illustrative and exemplary only, and are not restrictive of the invention. One of ordinary skill in the art would recognize that those arrangements or configurations, components and/or elements
15 used herein may be altered in a manner so as to obtain different effects or desired operating characteristics. As such, the above-described should not be construed as limiting in any way, but as a best mode contemplated by the inventor for carrying out the invention.

20 The invention being thus described, it will be obvious that the same may be varied in many ways. Such variations are not to be regarded as a departure from the principle and scope of the invention, and all such modifications as would be obvious to one skilled in the art intended to be included within the scope of following claims.

CLAIMS

1. A wireless tire monitoring device for a vehicle, the wireless tire monitoring device (100) includes:

- 5 a) a tire pressure / temperature signal transmitting device (110);
- b) at least one sensor unit (130) for measuring or detecting at least one parameter relating to the conditions of the tire (200);
- c) an antenna (150) for transmitting signal corresponding to the tire conditions;

10 wherein the wireless tire monitoring device (100) is detachably mounted to a valve stem (210) of the tire (200) and being served as a cap for the valve stem (210);

 wherein the antenna (150) includes at least one curvature strip (151) configured at same axis (Z – Z) with the valve stem (210) so that its centre axis aligns with the valve stem (210) of the tire (200); and

15 wherein the antenna (150) and valve stem (210) share a common axis (X – X) of a tire wheel (230) and adapted to be revolved about the common axis (X – X) of the tire wheel (230).

2. The wireless tire monitoring device (100) according to Claim 1, wherein the tire pressure / temperature signal transmitting device (110) is equipped with a battery holder (171) to accommodate a battery (170).

20

3. The wireless tire monitoring device (100) according to Claim 2, wherein the at least one curvature strip (151) of the antenna (150) is a fully, substantially or semi-circular strip adapted to be configured along the circumference of the battery holder (171).

25

4. The wireless tire monitoring device (100) according to Claim 1, wherein the antenna (150), which revolves about the common axis (X – X) of the tire wheel (230), is being oriented so that centre axis of the curvature strip (151) lies along with the axis (Z – Z) of the valve stem (210); and such configuration enables to avoid any inducing of Doppler frequency shift to transmitted signal.
- 5
5. The wireless tire monitoring device (100) according to Claim 4, wherein the valve stem (210), which tiltably extends from the tire (200), enables a radially transmission of the signals from the curvature strip (151) of the antenna (150) to be channelled or directed to the vehicle body.
- 10
6. The wireless tire monitoring device (100) according to Claim 5, wherein the radially transmission signals of the curvature strip (151) enables to eliminate any inconsistency or weak signals transmission, such that any loss of information or false information relating to the conditions of the tire (200) can be eliminated.
- 15
7. The wireless tire monitoring device (100) according to Claim 1, wherein the tire pressure / temperature signal transmitting device (110) is equipped with a micro-controller (112).
- 20
8. The wireless tire monitoring device (100) according to Claim 7 wherein the micro-controller (112) serves to process all related information received from the sensor unit (130) and transmits the information to other associated units in a tire pressure monitoring system (TPMS) via the antenna (150).
- 25
9. The wireless tire monitoring device (100) according to Claim 8, wherein the antenna (150) is electronically connected to the Bluetooth chip for Bluetooth

pairing, wireless communication or encryption, and for transmitting wireless signal relating to the tire conditions, in between the tire pressure / temperature signal transmitting device (110) and the other associated units in tire pressure monitoring system (TPMS).

5

10. The wireless tire monitoring device (100) according to Claim 9, wherein the antenna (150) is being controlled by the micro-controller (112) such that it facilitates prolonged periods of power consumption to continuously generate an ultra-low power consumption Bluetooth wave signal (300) to extend the useful life

10

of the battery (170).

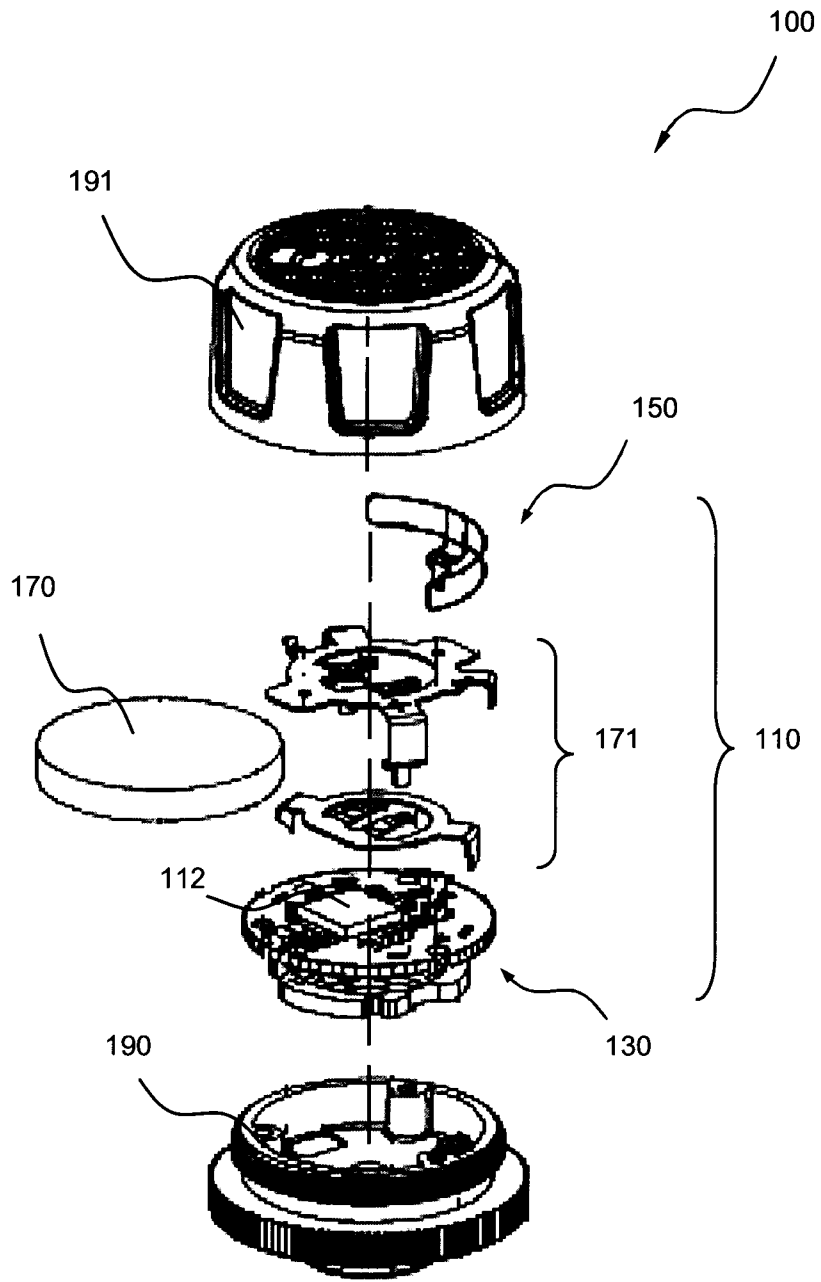
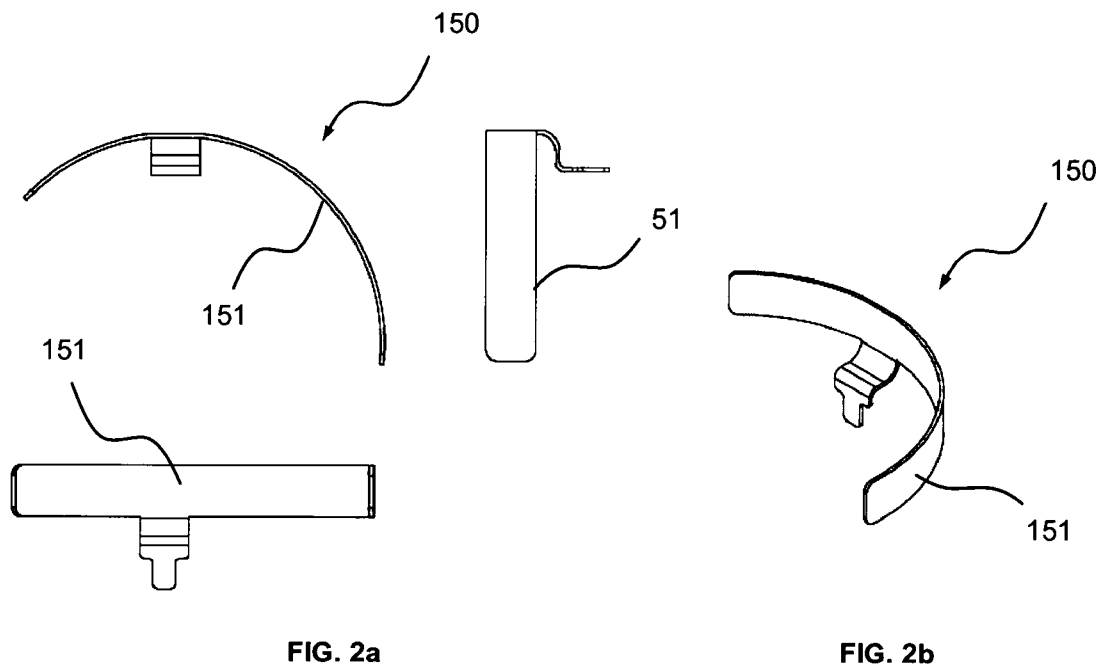
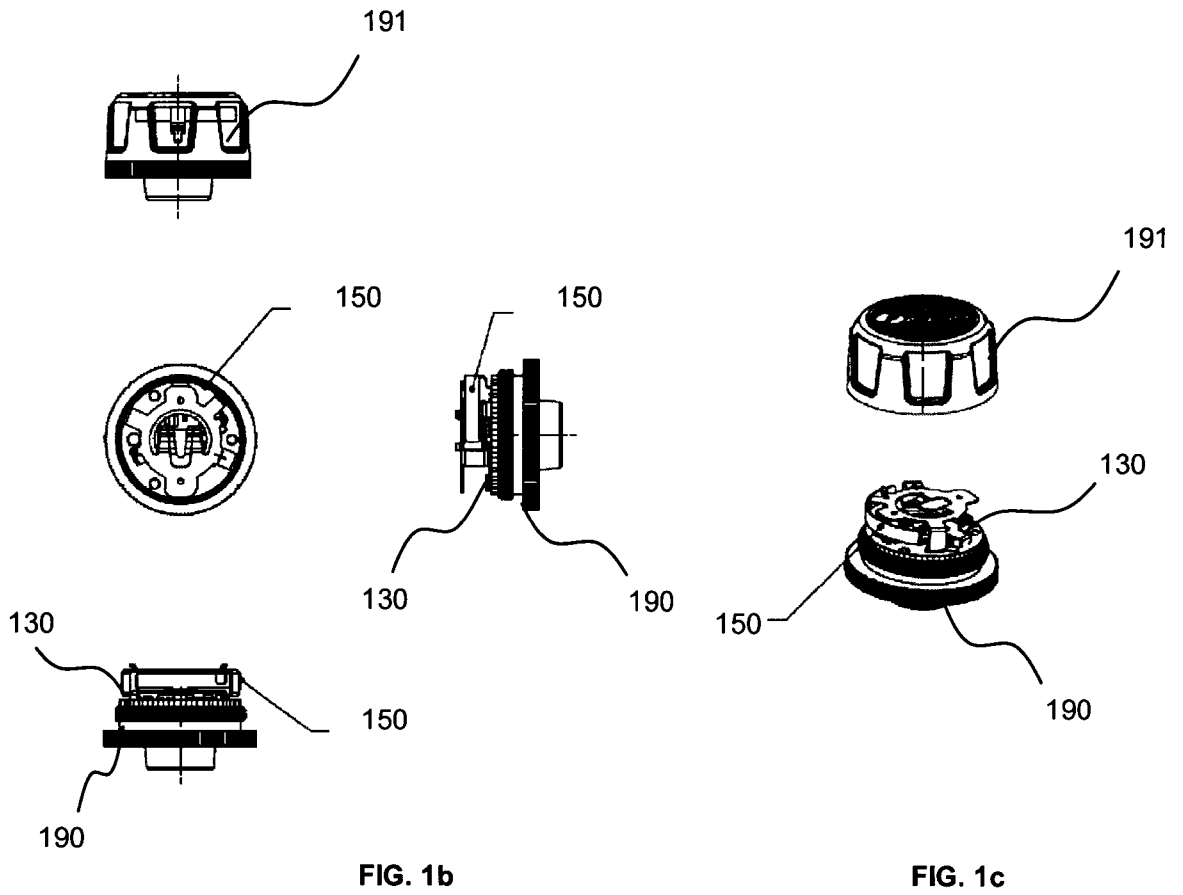

FIG. 1a



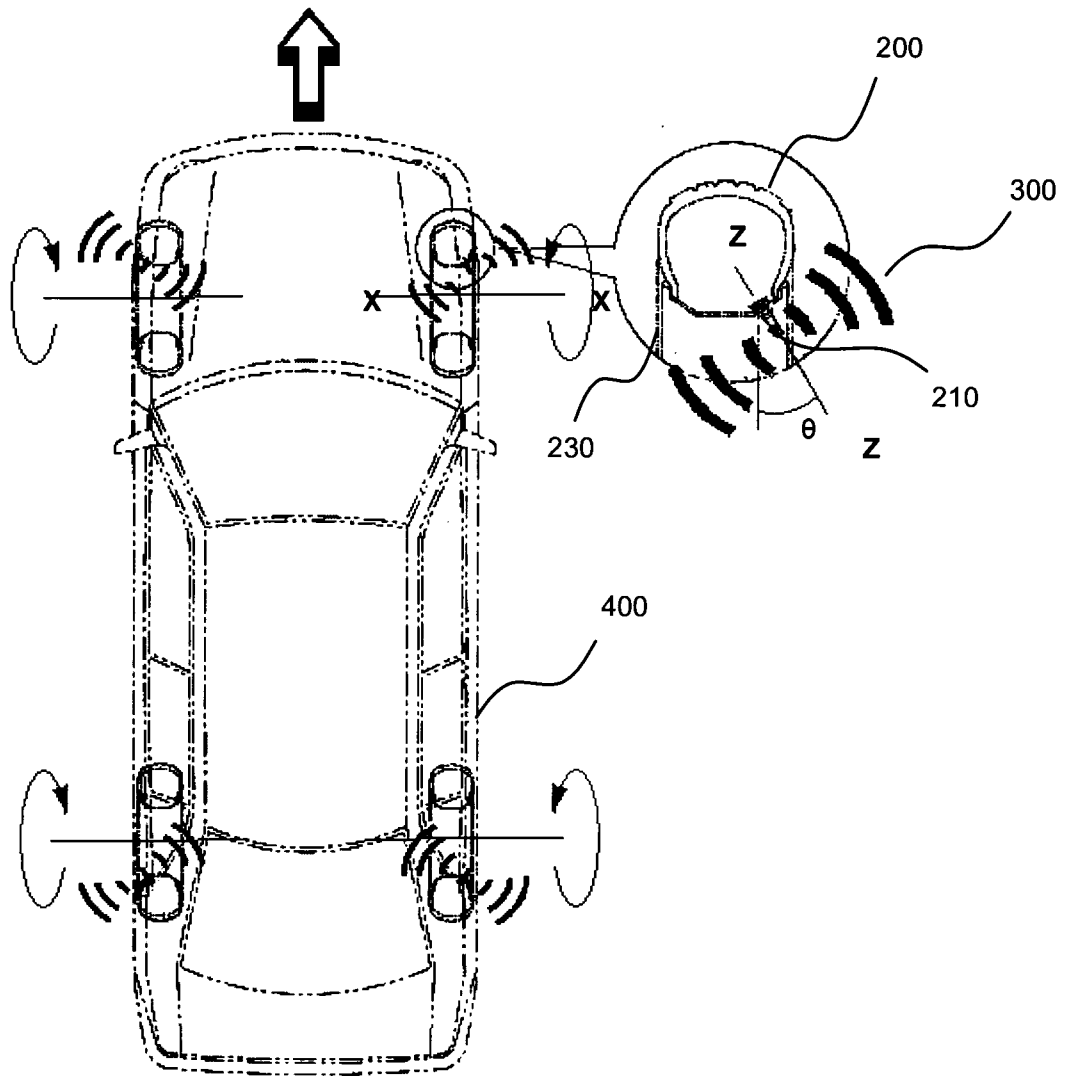

FIG. 3

A. CLASSIFICATION OF SUBJECT MATTER**B60C 23/00(2006.01)i, B60C 23/04(2006.01)i, B60C 23/20(2006.01)i**

According to International Patent Classification (IPC) or to both national classification and IPC

B. FIELDS SEARCHEDMinimum documentation searched (classification system followed by classification symbols)
B60C 23/00; G01M 17/02; B60C 23/02; B60C 23/04; B60C 23/20Documentation searched other than minimum documentation to the extent that such documents are included in the fields searched
Korean utility models and applications for utility models
Japanese utility models and applications for utility modelsElectronic data base consulted during the international search (name of data base and, where practicable, search terms used)
eKOMPASS(KIPO internal) & Keywords: wireless, monitoring, pressure, temperature, tire, antenna, battery, bluetooth and controller**C. DOCUMENTS CONSIDERED TO BE RELEVANT**

Category*	Citation of document, with indication, where appropriate, of the relevant passages	Relevant to claim No.
Y	US 2012-0176233 A1 (PETRUCELLI et al.) 12 July 2012 See paragraphs [0037]-[0042], [0053]; claim 1; and figure 4A.	1-10
Y	US 2003-0112137 A1 (SAHEKI, SETSUHIRO) 19 June 2003 See paragraph [0020] and figure 3.	1-10
A	US 2004-0031316 A1 (LUNDQVIST, TORBJORN BOSON) 19 February 2004 See paragraphs [0005]-[0008] and figures 1-3.	1-10
A	KR 10-2010-0109735 A (SEETRON INC.) 11 October 2010 See paragraphs [0008]-[0021] and figures 7-11.	1-10
A	WO 02-20287 A1 (AUTOMOTIVE TECHNOLOGIES INTERNATIONAL, INC.) 14 March 2002 See claims 1, 21 and figures 1A-1B.	1-10

 Further documents are listed in the continuation of Box C. See patent family annex.

* Special categories of cited documents:

"A" document defining the general state of the art which is not considered to be of particular relevance

"E" earlier application or patent but published on or after the international filing date

"L" document which may throw doubts on priority claim(s) or which is cited to establish the publication date of another citation or other special reason (as specified)

"O" document referring to an oral disclosure, use, exhibition or other means

"P" document published prior to the international filing date but later than the priority date claimed

"T" later document published after the international filing date or priority date and not in conflict with the application but cited to understand the principle or theory underlying the invention

"X" document of particular relevance; the claimed invention cannot be considered novel or cannot be considered to involve an inventive step when the document is taken alone

"Y" document of particular relevance; the claimed invention cannot be considered to involve an inventive step when the document is combined with one or more other such documents, such combination being obvious to a person skilled in the art

"&" document member of the same patent family

Date of the actual completion of the international search

11 March 2016 (11.03.2016)

Date of mailing of the international search report

11 March 2016 (11.03.2016)

Name and mailing address of the ISA/KR

International Application Division
Korean Intellectual Property Office
189 Cheongsa-ro, Seo-gu, Daejeon, 35208, Republic of Korea

Facsimile No. +82-42-472-7140

Authorized officer

BAE, Geun Tae

Telephone No. +82-42-481-3547



INTERNATIONAL SEARCH REPORT

Information on patent family members

International application No.

PCT/MY2015/000087

Patent document cited in search report	Publication date	Patent family member(s)	Publication date
US 2012-0176233 A1	12/07/2012	US 8618925 B2	31/12/2013
US 2003-0112137 A1	19/06/2003	EP 1321314 A2	25/06/2003
		EP 1321314 A3	19/11/2003
		JP 2003-182322 A	03/07/2003
		KR 10-2003-0051146 A	25/06/2003
		TW 528689 A	21/04/2003
US 2004-0031316 A1	19/02/2004	AU 2002-19805 A1	03/06/2002
		AU 2002-19805 B2	06/10/2005
		CA 2429593 A1	30/05/2002
		CN 1505754 A	16/06/2004
		CN 1505754 C	16/06/2004
		EP 1344038 A1	17/09/2003
		EP 1344038 A4	31/08/2005
		EP 1344038 B1	16/07/2008
		JP 2004-525016 A	19/08/2004
		KR 10-0620002 B1	12/09/2006
		KR 10-2003-0062413 A	25/07/2003
		US 2002-0059825 A1	23/05/2002
		US 6629454 B2	07/10/2003
		WO 02-42729 A1	30/05/2002
		WO 02-42729 A9	06/02/2003
KR 10-2010-0109735 A	11/10/2010	US 2012-0017672 A1	26/01/2012
		WO 2010-114187 A1	07/10/2010
WO 02-20287 A1	14/03/2002	AU 1999-15262 A1	07/06/1999
		AU 2000-18202 A1	05/06/2000
		AU 2000-35225 A1	28/09/2000
		AU 2001-19588 A1	25/06/2001
		AU 2001-59640 A1	20/11/2001
		EP 0952933 A1	18/06/2003
		EP 0952933 B1	12/01/2005
		GB 2289332 A	15/11/1995
		GB 2289542 A	22/11/1995
		GB 2289653 A	29/11/1995
		GB 2289786 A	29/11/1995
		GB 2301906 A	18/12/1996
		GB 2301922 A	18/12/1996
		GB 2308102 A	18/06/1997
		GB 2323340 A	23/09/1998
		GB 2324864 A	04/11/1998
		GB 2340978 A	01/03/2000
		GB 2360097 A	12/09/2001
		GB 2363638 A	02/01/2002
		GB 2363769 A	09/01/2002
		GB 2369737 A	05/06/2002
		GB 2373117 A	11/09/2002

INTERNATIONAL SEARCH REPORT

Information on patent family members

International application No.

PCT/MY2015/000087

Patent document cited in search report	Publication date	Patent family member(s)	Publication date
		GB 2383415 A	25/06/2003
		GB 2383415 B	23/02/2005
		GB 2405279 A	23/02/2005
		GB 2405931 A	16/03/2005
		GB 2406170 A	23/03/2005
		GB 2406171 A	23/03/2005
		GB 2406646 A	06/04/2005
		JP 08-175305 A	09/07/1996
		JP 08-198044 A	06/08/1996
		JP 09-175316 A	08/07/1997
		JP 09-189710 A	22/07/1997
		JP 09-240407 A	16/09/1997
		JP 09-501120 A	04/02/1997
		JP 2001-508732 A	03/07/2001
		JP 2002-501459 A	15/01/2002
		JP 2003-532959 A	05/11/2003
		JP 2004-518104 A	17/06/2004
		JP 2004-522932 A	29/07/2004
		JP 2005-306376 A	04/11/2005
		JP 3960394 B2	15/08/2007
		JP 3993253 B2	17/10/2007
		TW 541255 A	11/07/2003
		US 5155307 A	13/10/1992
		US 5192838 A	09/03/1993
		US 5231253 A	27/07/1993
		US 5233141 A	03/08/1993
		US 5326133 A	05/07/1994
		US 5389751 A	14/02/1995
		US 5441301 A	15/08/1995
		US 5505485 A	09/04/1996
		US 5629681 A	13/05/1997
		US 5653462 A	05/08/1997
		US 5653464 A	05/08/1997
		US 5684701 A	04/11/1997
		US 5694320 A	02/12/1997
		US 5746446 A	05/05/1998
		US 5748473 A	05/05/1998
		US 5772238 A	30/06/1998
		US 5809437 A	15/09/1998
		US 5822707 A	13/10/1998
		US 5829782 A	03/11/1998
		US 5835613 A	10/11/1998
		US 5845000 A	01/12/1998
		US 5848802 A	15/12/1998
		US 5863068 A	26/01/1999
		US 5901978 A	11/05/1999
		US 5943295 A	24/08/1999
		US 6009970 A	04/01/2000
		US 6039139 A	21/03/2000
		US 6078854 A	20/06/2000

INTERNATIONAL SEARCH REPORT

Information on patent family members

International application No.

PCT/MY2015/000087

Patent document cited in search report	Publication date	Patent family member(s)	Publication date
		US 6081757 A	27/06/2000
		US 6088640 A	11/07/2000
		US 6116639 A	12/09/2000
		US 6134492 A	17/10/2000
		US 6141432 A	31/10/2000
		US 6149194 A	21/11/2000
		US 6168198 B1	02/01/2001
		US 6175787 B1	16/01/2001
		US 6179326 B1	30/01/2001
		US 6186537 B1	13/02/2001
		US 6206129 B1	27/03/2001
		US 6209909 B1	03/04/2001
		US 6234519 B1	22/05/2001
		US 6234520 B1	22/05/2001
		US 6242701 B1	05/06/2001
		US 6250668 B1	26/06/2001
		US 6253134 B1	26/06/2001
		US 6254127 B1	03/07/2001
		US 6270116 B1	07/08/2001
		US 6279946 B1	28/08/2001
		US 6283503 B1	04/09/2001
		US 6324453 B1	27/11/2001
		US 6325414 B2	04/12/2001
		US 6326704 B1	04/12/2001
		US 6328126 B2	11/12/2001
		US 6330501 B1	11/12/2001
		US 6343810 B1	05/02/2002
		US 6370475 B1	09/04/2002
		US 6393133 B1	21/05/2002
		US 6397136 B1	28/05/2002
		US 6405132 B1	11/06/2002
		US 6412813 B1	02/07/2002
		US 6422595 B1	23/07/2002
		US 6442465 B2	27/08/2002
		US 6442504 B1	27/08/2002
		US 6445988 B1	03/09/2002
		US 6452870 B1	17/09/2002
		US 6459973 B1	01/10/2002
		US 6474683 B1	05/11/2002
		US 6484080 B2	19/11/2002
		US 6507779 B2	14/01/2003
		US 6513830 B2	04/02/2003
		US 6513833 B2	04/02/2003
		US 6517107 B2	11/02/2003
		US 6526352 B1	25/02/2003
		US 6529809 B1	04/03/2003
		US 6532408 B1	11/03/2003
		US 6533316 B2	18/03/2003
		US 6553296 B2	22/04/2003
		US 6555766 B2	29/04/2003

INTERNATIONAL SEARCH REPORT

Information on patent family members

International application No.

PCT/MY2015/000087

Patent document cited in search report	Publication date	Patent family member(s)	Publication date
		US 6557889 B2	06/05/2003
		US 6609053 B1	19/08/2003
		US 6615656 B1	09/09/2003
		US 6623033 B2	23/09/2003
		US 6648367 B2	18/11/2003
		US 6653577 B2	25/11/2003
		US 6662642 B2	16/12/2003
		US 6685218 B1	03/02/2004
		US 6689962 B2	10/02/2004
		US 6712387 B1	30/03/2004
		US 6715790 B2	06/04/2004
		US 6720920 B2	13/04/2004
		US 6731569 B2	04/05/2004
		US 6733036 B2	11/05/2004
		US 6735506 B2	11/05/2004
		US 6736231 B2	18/05/2004
		US 6738697 B2	18/05/2004
		US 6746078 B2	08/06/2004
		US 6748797 B2	15/06/2004
		US 6749218 B2	15/06/2004
		US 6755273 B2	29/06/2004
		US 6757602 B2	29/06/2004
		US 6768944 B2	27/07/2004
		US 6772057 B2	03/08/2004
		US 6778672 B2	17/08/2004
		US 6782316 B2	24/08/2004
		US 6784379 B2	31/08/2004
		US 6792342 B2	14/09/2004
		US 6793242 B2	21/09/2004
		US 6805404 B1	19/10/2004
		US 6820897 B2	23/11/2004
		US 6823244 B2	23/11/2004
		US 6833516 B2	21/12/2004
		US 6850824 B2	01/02/2005
		US 6856873 B2	15/02/2005
		US 6856876 B2	15/02/2005
		US 6869100 B2	22/03/2005
		US 6875976 B2	05/04/2005
		US 6885968 B2	26/04/2005
		US 6892572 B2	17/05/2005
		US 6899134 B2	31/05/2005
		US 6905135 B2	14/06/2005
		US 6910711 B1	28/06/2005
		US 6918459 B2	19/07/2005
		US 6919803 B2	19/07/2005
		US 6942248 B2	13/09/2005
		US 6950022 B2	27/09/2005
		US 6958451 B2	25/10/2005
		US 6984818 B1	10/01/2006
		US 6988026 B2	17/01/2006

INTERNATIONAL SEARCH REPORT

Information on patent family members

International application No.

PCT/MY2015/000087

Patent document cited in search report	Publication date	Patent family member(s)	Publication date
		US 7025379 B2	11/04/2006
		US 7040653 B1	09/05/2006
		US 7049945 B2	23/05/2006
		US 7050897 B2	23/05/2006
		US 7052038 B2	30/05/2006
		US 7070202 B2	04/07/2006
		US 7079450 B2	18/07/2006
		US 7082359 B2	25/07/2006
		US 7085637 B2	01/08/2006
		US 7089099 B2	08/08/2006
		US 7097201 B2	29/08/2006
		US 7103460 B1	05/09/2006
		US 7110880 B2	19/09/2006
		US 7126583 B1	24/10/2006
		US 7134687 B2	14/11/2006
		US 7147246 B2	12/12/2006
		US 7164117 B2	16/01/2007
		US 7202776 B2	10/04/2007
		US 7209221 B2	24/04/2007
		US 7243945 B2	17/07/2007
		US 7253725 B2	07/08/2007
		US 7284769 B2	23/10/2007
		US 7295925 B2	13/11/2007
		US 7313467 B2	25/12/2007
		US 7324039 B2	29/01/2008
		US 7330784 B2	12/02/2008
		US 7334657 B2	26/02/2008
		US 7338069 B2	04/03/2008
		US 7359527 B2	15/04/2008
		US 7359782 B2	15/04/2008
		US 7379800 B2	27/05/2008
		US 7386372 B2	10/06/2008
		US 7387183 B2	17/06/2008
		US 7401807 B2	22/07/2008
		US 7407029 B2	05/08/2008
		US 7408453 B2	05/08/2008
		US 7413048 B2	19/08/2008
		US 7415126 B2	19/08/2008
		US 7418346 B2	26/08/2008
		US 7421321 B2	02/09/2008
		US 7426437 B2	16/09/2008
		US 7444210 B2	28/10/2008
		US 7467034 B2	16/12/2008
		US 7467809 B2	23/12/2008
		US 7481453 B2	27/01/2009
		US 7523803 B2	28/04/2009
		US 7527288 B2	05/05/2009
		US 7549327 B2	23/06/2009
		US 7555370 B2	30/06/2009
		US 7570785 B2	04/08/2009

INTERNATIONAL SEARCH REPORT

Information on patent family members

International application No.

PCT/MY2015/000087

Patent document cited in search report	Publication date	Patent family member(s)	Publication date
		US 7575248 B2	18/08/2009
		US 7580782 B2	25/08/2009
		US 7588115 B2	15/09/2009
		US 7596242 B2	29/09/2009
		US 7602313 B2	13/10/2009
		US 7603894 B2	20/10/2009
		US 7604080 B2	20/10/2009
		US 7610146 B2	27/10/2009
		US 7620521 B2	17/11/2009
		US 7629899 B2	08/12/2009
		US 7630802 B2	08/12/2009
		US 7630806 B2	08/12/2009
		US 7635043 B2	22/12/2009
		US 7647180 B2	12/01/2010
		US 7648164 B2	19/01/2010
		US 7650210 B2	19/01/2010
		US 7650212 B2	19/01/2010
		US 7655895 B2	02/02/2010
		US 7657354 B2	02/02/2010
		US 7660437 B2	09/02/2010
		US 7663502 B2	16/02/2010
		US 7672756 B2	02/03/2010
		US 7676062 B2	09/03/2010
		US 7693626 B2	06/04/2010
		US 7695015 B2	13/04/2010
		US 7712777 B2	11/05/2010
		US 7726684 B2	01/06/2010
		US 7734061 B2	08/06/2010
		US 7738678 B2	15/06/2010
		US 7740273 B2	22/06/2010
		US 7744122 B2	29/06/2010
		US 7760080 B2	20/07/2010
		US 7762580 B2	27/07/2010
		US 7762582 B2	27/07/2010
		US 7766383 B2	03/08/2010
		US 7768380 B2	03/08/2010
		US 7769513 B2	03/08/2010
		US 7770920 B2	10/08/2010
		US 7779956 B2	24/08/2010
		US 7783403 B2	24/08/2010
		US 7786864 B1	31/08/2010
		US 7788008 B2	31/08/2010
		US 7791503 B2	07/09/2010
		US 7796081 B2	14/09/2010
		US 7815219 B2	19/10/2010
		US 7819003 B2	26/10/2010
		US 7831358 B2	09/11/2010
		US 7832762 B2	16/11/2010
		US 7840342 B1	23/11/2010
		US 7840355 B2	23/11/2010

INTERNATIONAL SEARCH REPORT

Information on patent family members

International application No.

PCT/MY2015/000087

Patent document cited in search report	Publication date	Patent family member(s)	Publication date
		US 7852462 B2	14/12/2010
		US 7860626 B2	28/12/2010
		US 7880594 B2	01/02/2011
		US 7887089 B2	15/02/2011
		US 7889096 B2	15/02/2011