

(19) World Intellectual Property Organization  
International Bureau



(43) International Publication Date  
27 September 2007 (27.09.2007)

PCT

(10) International Publication Number  
**WO 2007/107629 A1**

- (51) International Patent Classification:  
F24J 3/08 (2006.01) F24D 15/04 (2006.01)
- (21) International Application Number:  
PCT/FI2007/050140
- (22) International Filing Date: 15 March 2007 (15.03.2007)
- (25) Filing Language: Finnish
- (26) Publication Language: English
- (30) Priority Data:  
20065172 16 March 2006 (16.03.2006) FI
- (71) Applicant (for all designated States except US): MAT-EVE OY [FI/FI]; Rajalammentie 32, FI-65280 Vaasa (FI).
- (72) Inventors; and
- (75) Inventors/Applicants (for US only): PANULA, Erkki-Jussi [FI/FI]; Mittakepintie 4, FI-SEINÄJOKI 60200 (FI). LIESKOSKI, Mauri [FI/FI]; Rajalammentie 32, FI-65280 Vaasa (FI).
- (74) Agent: KOLSTER OY AB; Iso Roobertinkatu 23, P.O.Box 148, FI-00121 Helsinki (FI).
- (81) Designated States (unless otherwise indicated, for every kind of national protection available): AE, AG, AL, AM,

AT, AU, AZ, BA, BB, BG, BR, BW, BY, BZ, CA, CH, CN, CO, CR, CU, CZ, DE, DK, DM, DZ, EC, EE, EG, ES, FI, GB, GD, GE, GH, GM, GT, HN, HR, HU, ID, IL, IN, IS, JP, KE, KG, KM, KN, KP, KR, KZ, LA, LC, LK, LR, LS, LT, LU, LY, MA, MD, MG, MK, MN, MW, MX, MY, MZ, NA, NG, NI, NO, NZ, OM, PG, PH, PL, PT, RO, RS, RU, SC, SD, SE, SG, SK, SL, SM, SV, SY, TJ, TM, TN, TR, TT, TZ, UA, UG, US, UZ, VC, VN, ZA, ZM, ZW.

(84) Designated States (unless otherwise indicated, for every kind of regional protection available): ARIPO (BW, GH, GM, KE, LS, MW, MZ, NA, SD, SL, SZ, TZ, UG, ZM, ZW), Eurasian (AM, AZ, BY, KG, KZ, MD, RU, TJ, TM), European (AT, BE, BG, CH, CY, CZ, DE, DK, EE, ES, FI, FR, GB, GR, HU, IE, IS, IT, LT, LU, LV, MC, MT, NL, PL, PT, RO, SE, SI, SK, TR), OAPI (BF, BJ, CF, CG, CI, CM, GA, GN, GQ, GW, ML, MR, NE, SN, TD, TG).

Declaration under Rule 4.17:  
— of inventorship (Rule 4.17(iv))

Published:  
— with international search report

For two-letter codes and other abbreviations, refer to the "Guidance Notes on Codes and Abbreviations" appearing at the beginning of each regular issue of the PCT Gazette.

(54) Title: SYSTEM AND DISTRIBUTION TANK FOR LOW-ENERGY NETWORK

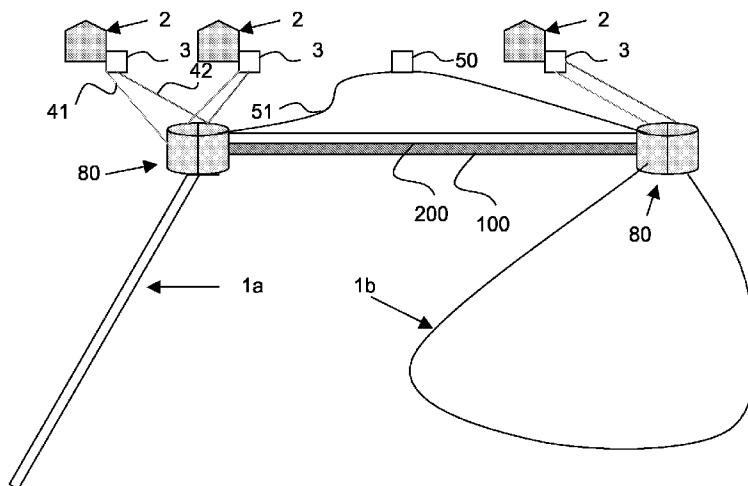

(57) Abstract: The invention relates to a system for a low-energy network, comprising a collector circuit (1a, 1b) filled with a first transfer solution, a heat transfer circuit (7) filled with a second transfer solution, and a terminal (3) adapted to transfer heat between the transfer solutions of the collector circuit (1a, 1b) and the heat transfer circuit (7). The system is characterized in that the collector circuits (1a, 1b) are connected to the terminal via two distribution reservoirs (82, 81), of which the first distribution reservoir (81) is isolated and configured to receive and transfer heated transfer liquid, and the second distribution reservoir (82) is configured to receive and transfer cooled transfer liquid, and at least one collector circuit (1a,1b) connecting the first distribution reservoir (81) and the second distribution reservoir (82) is connected to each distribution reservoir (81, 82) terminating the low-energy network. The invention further relates to a distribution tank (80) for a low-energy network.

WO 2007/107629 A1

## SYSTEM AND DISTRIBUTION TANK FOR LOW-ENERGY NETWORK

### BACKGROUND OF THE INVENTION

**[0001]** The invention relates to the utilization of low energy, such as geothermal heat, and particularly to a system for transferring heat with a terminal, such as a heat pump or the like, from the earth or water via a transfer medium.

**[0002]** In present practice, the utilization of low energy obtained from the earth, water or rock refers to heating of a building and service water by means of a pump and a heat collector circuit. The operating principle of such a geothermal heat system corresponds to that of a freezer, but is reverse: the system cools the earth and heats a water accumulator, for example. Often 2 to 3 units of heat are obtained per electric energy unit employed. The performance is significantly better than in direct electric heating. The consumption of heating energy in properties is significant under cold weather conditions. The utilization of geothermal heat is increasingly cost-effective as the costs of electricity and oil continue to rise.

**[0003]** Alternatively, a geothermal heat pump system may be utilized also for cooling interiors, for example by circulating a cool solution from the earth through a cooler located in the incoming airflow.

**[0004]** A common manner of heat recovery is a pipework located horizontally at a depth of 1 to 1.2 metres. However, such a pipework requires a wide surface area, which renders it usable only in large plots of land. The collector circuit may be located in the ground or in water. The placement of a horizontal pipework in the ground requires that a pipe ditch be dug in the entire area of the collector circuit. The pipe loops of the circuit have to be at a distance of at least 1.5 metres from each other in order for adjacent loops not to interfere with each other's heat recovery. The placement of a horizontal pipe in a park, for example, is difficult without harming plants and roots of trees.

**[0005]** A thermal well is another common manner of heat recovery. It involves the immersion of a pipework into a hole drilled in a rock. A thermal well, i.e. a drilled well, is usually drilled vertically. Very little surface area is required for a thermal well compared with a horizontal pipework. However, a significant layer of loose ground may exist on top of the rock. The loose ground has to be provided with a protecting tube, which raises costs. Accordingly, ground having a thick layer of loose ground, restricts the placement of a ther-

mal well. Heat yield in a thermal well is usually higher than in a horizontal pipework. Heat yield from a thermal well partly depends on the flow of groundwater. However, it is impossible to estimate the flow of groundwater without implementing expensive drilling.

**[0006]** A third manner of heat recovery is to place a heat collector pipework at the bottom of a lake or other waterway, whereby heat is transferred from the bottom sediment and water to a transfer solution. The pipe may be transported to the water in the ground, but in that case, separate trenches should exist for the inlet and outlet pipes. A pipework located in water is easy to install at the bottom of a waterway. However, a pipe filled with solution is lighter than water, and therefore tends to rise upwards. Risen pipe sections may cause air pockets that interfere with the circulation. Accordingly, the pipe has to be anchored to the bottom with the use of a sufficient number of weights. A pipework placed at the bottom is also always susceptible to damage. An anchor of a boat or the like may engage the pipework and damage the pipe. At the water line, the inlet and outlet pipes have to be buried into the bottom in order for ice not to break the pipework.

**[0007]** The selection between these three manners depends on the location, area and ground of the available area. Previously, the aim was to implement geothermal networks in such a manner that several houses share one common, larger heat collector circuit. However, to connect several properties to such a system requires a corresponding extension of the heat collector circuit.

## BRIEF DESCRIPTION OF THE INVENTION

**[0008]** An object of the invention is thus to provide a system for a low-energy network and a distribution tank for the system in a manner allowing the above problems to be solved. The object of the invention is achieved with a system and a distribution tank that are characterized in what is stated in the independent claims. Preferred embodiments of the invention are described in the dependent claims.

**[0009]** The invention is based on interconnecting the distribution tanks of a low-energy network with a main pipework and on optionally connecting ground circuits and heating circuits via a terminal to the distribution tanks according to the need. In each location, the ground circuits may be implemented in a suitable manner. Accordingly, the ground circuit may also be lo-

cated at the bottom of a waterway. In addition, the system is expandable or, alternatively, heating circuits or ground circuits can be removed therefrom or closed without restricting the operation of the rest of the system sections.

**[0010]** An aspect of the invention is to provide a system for implementing a low-energy network.

**[0011]** Another aspect of the invention is to provide a distribution tank for a low-energy network.

**[0012]** In accordance with an embodiment of an aspect of the invention, the system comprises a collector circuit filled with a first transfer solution, a heat transfer circuit filled with a second transfer solution, and a terminal adapted to transfer heat between the transfer solutions of the collector circuit and the heat transfer circuit, wherein the collector circuits are connected to the terminal via two distribution reservoirs, of which the first distribution reservoir is isolated and configured to receive and transfer heated transfer liquid, and the second distribution reservoir is configured to receive and transfer cooled transfer liquid, and at least one collector circuit connecting the first distribution reservoir and the second distribution reservoir is connected to each distribution reservoir terminating the low-energy network. Herein, a terminating distribution reservoir refers to a reservoir from which the network starts or to which it ends. The network of the invention does not limit the shape and routes of the network. The network may be implemented in circuit form, whereby the network starts and ends at the same terminating distribution reservoir. Similarly, the network of the invention may be stellate, whereby there are several terminating distribution reservoirs. An advantage of the invention is that the network may be expanded without restrictions. For example, a network extension may be connected by means of a main pipework and distribution reservoirs to any distribution reservoir of a network implemented in circuit form. In this case, the distribution reservoirs separate from the circuit serve as terminating distribution reservoirs.

**[0013]** In accordance with an embodiment, first distribution reservoirs and second distribution reservoirs are interconnected in the distribution tank. The distribution reservoirs are arranged in the distribution tank in such a manner that an isolation section for decreasing heat transfer between the reservoirs is arranged between the distribution reservoirs.

**[0014]** The distribution tanks are connected with a first main pipe for transferring transfer solution cooled with a terminal, such as a geothermal

pump or the like, and with a second main pipe for transferring transfer solution heated in the ground circuit. The first main pipe can be isolated, allowing main pipes to be placed in each other's vicinity without any significant heat transfer therebetween. The thickness of the isolation of the first main pipe may be increased or decreased depending on the installation depths of the main pipes or the distance therebetween. Preferably, the main pipes may be placed in the same dug ditch on top of each other, which eliminates the need to dig separate ditches. The depth of placement of the main pipes may vary, but it may be 1 to 2 metres, for example, allowing a non-isolated main pipe to receive heat from the ground.

**[0015]** The second main pipe is non-isolated in a manner allowing thermal energy to transfer between the transfer liquid in the pipe and the ground outside the pipe. This being so, the main pipes also serve as part of the collector circuits that may be utilized for both heating and cooling of properties.

**[0016]** In accordance with an embodiment of the invention, each ground circuit connected to a distribution tank is provided with measuring means and adjusting means in a manner enabling the measurement of the heat production of each collector circuit with the measuring means and the flow rate of each collector circuit is separately adjustable with the adjusting means to conform with the requirement of the terminals. This enables the use of a control system for electric control of the adjusting means of the distribution tank. The connection of the adjusting means and measuring means of the distribution tank to the control system may be not only a wired connection, but also a wireless data communication connection. A wireless connection to the control system may facilitate the implementation of the system, in connection with expansion of the system, for example.

**[0017]** The control system enables the restriction of the flow of the different collector circuits such that transfer liquid is obtained to the terminal from the most advantageous collector circuit or collector circuits. In other words, the control system is used to adjust the flow rates of the collector circuits in a manner allowing the temperature of the transfer liquid to be set to a level wherein the performance of the terminals is maximally high. In this case, one terminal may utilize other collector circuits connected to the system in addition to or instead of its 'own' collector circuit.

**[0018]** Separate collector circuits cannot be positioned on all properties. In the solution of the invention, such properties may also be connected

to the system through terminals. A measuring apparatus connected to the terminals may be used as billing basis. An advantage of the invention is explicitly that the flow of the collector circuits may be implemented by means of terminals, without a separate pump. When all terminals are closed, the flow stops and the temperature of the transfer liquid settles to correspond to the temperature of the surrounding ground or water. However, it is possible to provide larger systems, for example, with a separate pump.

**[0019]** Consequently, it is to be noted that the network may be provided with distribution tanks without a single ground circuit. Such a situation may arise for instance in the case of a multi-storey building, wherein several heat circuits of properties are connected to one distribution tank, and the ground circuits are implemented at a near-by field area or below a park, for example.

**[0020]** However, at least one ground circuit is connected to each terminating distribution tank of a low-energy network in order for the transfer solution to be transferred from the main pipe to another without directly mixing cooled and warmed liquids. The ground circuit may be selected according to the location of the distribution tank. For example, the ground circuit may be a horizontal circuit, a vertical or obliquely downwards directed pipe having an outer and an inner pipe, a thermal well drilled in rock or a pipework placed in a waterway. One or more ground circuits may be placed in one distribution tank in accordance with the location and the ground.

**[0021]** In accordance with another aspect of the invention, a distribution tank for a low-energy network comprises two reservoirs, a first reservoir and a second reservoir, of which the first reservoir is intended to receive and transfer heated transfer liquid and the second reservoir is intended to receive and transfer cooled transfer liquid. The reservoirs are provided with main pipe receiving means for receiving the main pipes into a first and a second space, respectively, and receiving means for ground circuits and/or terminal pipeworks for receiving the pipeworks into a first and a second space, respectively. The number of ground circuit and/or terminal receiving means may vary. A distribution tank may be prepared for connection under factory conditions, and therefore it would be advantageous to reserve extra connection points for possible network extensions or changes.

**[0022]** An isolation section separates the first reservoir from the second reservoir. The isolation section serves to minimize heat transfer be-

tween cold liquid and liquid heated in a ground circuit. The first and second reservoirs of the distribution tank preferably have a volume that stores liquid in the reservoir. The distribution reservoirs equalize the flow in the pipeworks and enable an even flow control for each pipe originating from the distribution reservoir.

#### BRIEF DESCRIPTION OF THE FIGURES

**[0023]** In the following, the invention will be described in more detail in connection with preferred embodiments with reference to the accompanying drawings, in which

Figure 1 schematically shows an embodiment of the system of the present invention;

Figure 2 shows a second embodiment of the system of the present invention;

Figure 3 shows a third embodiment of the system of the present invention;

Figure 4 shows a front view of an embodiment of the distribution tank of the present invention;

Figure 5 shows a front view of a second embodiment of the distribution tank of the present invention;

Figure 6 shows a top view of the second embodiment of the distribution tank of the present invention;

Figure 7 is a partial view of an embodiment of an end part of a pipe to be connected to a distribution tank of the present invention.

#### DETAILED DESCRIPTION OF THE INVENTION

**[0024]** Referring to Figure 1, wherein an embodiment of the system according to the present invention is shown, a pipe 1a comprising an inner and an outer tube is located obliquely below ground level, a second collector tube 1b being a pipe constituting a one-piece circuit. A terminal 3 utilizes the low energy accumulated in the pipework 1a and 1b, and transfers it to a house 2 via a transfer pipe 41, wherein it circulates via a heating circuit 7 and returns via a transfer pipe 42 to the collector pipework 1a, 1b. The number, length, inclination etc. of the pipes 1a, 1b may vary in accordance with the energy requirement and/or ground.

**[0025]** The terminal 3 may be a geothermal pump, for example. The terminal 3 is connected to the collector circuits 1a and 1b via distribution tanks

80. The collector circuits 7 are connected to the terminal 3 via two distribution reservoirs 82, 81. The first distribution reservoir 81 is isolated and configured to receive and transfer heated transfer liquid, the second distribution reservoir 82 being configured to receive and transfer cooled transfer medium. One collector circuit 1a, 1b for connecting the first distribution reservoir 81 and the second distribution reservoir 82 is connected to each distribution reservoir terminating the low-energy network. Thus, the transfer solution may be transferred from one main pipe to another without direct mixing of the cooled and heated liquid. Figure 1 only shows two distribution tanks 80, but it is obvious that the system may comprise a plurality of distribution tanks 80. This being so, distribution tanks having no collector circuits can be placed between the terminating distribution tanks 80 of the system, such tanks having connected thereto not only main pipes 100, 200, but also transfer pipes 41, 42 to the terminals of the properties. An applicable connecting manner also allows the direct connection (not shown) of the transfer pipe of one house 2, for example, to the main pipes 100, 200.

**[0026]** Figure 2 shows a second embodiment of the system according to the present invention. The terminals 3 of two houses 2 are connected to the distribution tank 80 located on the left, the terminal 3 of one house 2 being connected to the distribution tank located on the right. The flow in the collector pipes connected to the distribution tanks 80 is controlled with a control system 50. In the case of heating, wherein for instance the terminal 3 starts and when the transfer liquid of collector circuit 1b is warmer than the liquid of collector circuit 1a, the control system is able to restrict the flow of collector circuit 1a and increase the flow of collector circuit 1b such that the terminal is able to receive transfer liquid that is as warm as is preferable in view of performance. In the case of cooling, the situation is naturally reversed.

**[0027]** The control system 50 includes preset data for each collector circuit connected thereto and is able to use the data to restrict or increase the flow of each collector circuit to achieve the desired end temperature. In addition, the temperature of the transfer liquid returning from the collector pipe is measured with measuring means, in response to which the control system is able to perform an adjustment. For example, the control system may have information on the lengths of the main pipes, allowing it to also take into account a change in the temperature occurring in the main pipe.

**[0028]** Figure 3 shows a third embodiment of the system according

to the present invention, wherein the control system 50 is connected to one distribution tank by a wired connection and to another distribution tank 80 by a wireless connection. In the case of the wireless connection, the control system 50 and the distribution tank are provided with appropriate transmission and reception means 51a, 51b. The control system 50 is preferably connected to an information network, such as the Internet. This enables remote monitoring and control of the system.

**[0029]** Figure 4 shows a front view of an embodiment of the distribution tank according to the present invention. The distribution tank 80 comprises a first reservoir 81 and a second reservoir 82, of which the first reservoir 81 is intended to receive and transfer heated transfer liquid, the second reservoir 82 being intended to receive and transfer cooled transfer liquid. The reservoirs comprise main pipe receiving means 110, 210 for receiving the main pipes 100, 200 to the first and second distribution reservoir 81, 82, respectively. In this embodiment, the main pipe receiving means 110, 210 are tubular sections that project from the distribution tank 80 and to which the main pipes 100, 200 may be connected in an appropriate manner, by welding, for example. The figure further shows ground circuit and/or terminal pipe receiving means 11, 12 for receiving the pipeworks in the first and second space 81, 82, respectively. The figure only shows one pair of each receiving means, but it is evident that their number may vary.

**[0030]** When the receiving means 11, 12, 110, 120 are manufactured such that their ends are closed before installation, their number may be set larger, taking into account a possible expansion of the system. In this case, it would be preferable to reserve at least one extra pair of main pipe receiving means 110, 120 in each distribution tank. The first reservoir 81 and second reservoir 82 of the distribution tank 80 are separated with an isolation section 86. The figures show an embodiment, wherein the distribution tank is round when observed from above, the distribution reservoirs therein being semicircles. However, it is evident that both the distribution tank and the reservoirs therein may be of different shapes. For example, the distribution reservoirs may be placed on top of each other, allowing also them to have a cylindrical shape. It is also possible to place the distribution reservoirs separately, for example in larger systems, wherein the number of pipes to be connected is large.

**[0031]** Figure 5 shows a front view of the second embodiment of the distribution tank according to the present invention. The distribution tank 80 is

provided with measuring means 83 and adjusting means 85. In this embodiment, the measuring means 83 are placed in the receiving means 11 of the pipeworks of the ground circuits, and the adjusting means 85 to the receiving means 12 of the pipework of the ground circuits. However, the location of the measuring means 83 and the adjusting means 85 may vary for instance such that they are located at the same point. Two arrows show the transfer of heat from the ground to the second, non-isolated distribution reservoir 82. The system may further comprise shutoff means (not shown), by means of which one or more network section may be separated for the duration of repair or expansion of the network, for example.

**[0032]** Figure 6 shows a top view of the second embodiment of the distribution tank according to the present invention. The isolation section 86 is placed between the first distribution reservoir 81 and the second distribution reservoir 82.

**[0033]** Figure 7 is a partial view of an embodiment of the end section of the pipe 1a (shown in Figures 1 to 3) to be connected to a distribution tank according to the present invention. The transfer liquid is transferable via a cover part 60 in the pipe 1 to the distribution tank. The cover part 60 comprises an inner connecting sleeve 61, which is connected inside the pipe 1 to the inner pipe 10, and an outer connecting sleeve 62, with which the transfer liquid of the outer pipe 20 can be led to a separate pipe. The cover part 60 can be connected to the pipes to be connected to the distribution tank by conventional methods, by welding, for example.

**[0034]** It is obvious to a person skilled in the art that as technology advances, the basic idea of the invention can be implemented in a variety of ways. Consequently, the invention and its embodiments are not restricted to the above examples, but may vary within the scope of the claims.

## CLAIMS

1. A system for a low-energy network, comprising:  
a collector circuit (1a, 1b) filled with a first transfer solution,  
a heat transfer circuit (7) filled with a second transfer solution,  
a terminal (3) adapted to transfer heat between the transfer solutions of the collector circuit (1a, 1b) and the heat transfer circuit (7),  
c h a r a c t e r i z e d in that  
the collector circuits (7) are connected to the terminal (3) via two distribution reservoirs (82, 81), of which  
the first distribution reservoir (81) is isolated and configured to receive and transfer heated transfer liquid, and the second distribution reservoir (82) is configured to receive and transfer cooled transfer liquid,  
and at least one collector circuit (1a, 1b) connecting the first distribution reservoir (81) and the second distribution reservoir (82) is connected to each distribution reservoir terminating the low-energy network.
2. A system as claimed in claim 1, c h a r a c t e r i z e d in that the first distribution reservoirs (81) and the second distribution reservoirs (82) are interconnected in a distribution tank (80) in such a manner that an isolation section (83) is arranged between the distribution reservoirs.
3. A system as claimed in claim 1 or 2, c h a r a c t e r i z e d in that the distribution reservoirs (82, 81) are interconnected with a first main pipe (100) and a second main pipe (200), one of which is arranged to enable transfer of heat energy between the transfer liquid in the pipe and the ground outside the pipe.
4. A system as claimed in any one of claims 1 to 3, c h a r a c t e r i z e d in that that each collector circuit (1a, 1b) connected to the distribution reservoirs (81, 82) is provided with measuring means (83) and adjusting means (85) in a manner enabling the measurement of the heat production of each collector circuit with the measuring means (83), the flow rate of each collector circuit (1a, 1b) being separately adjustable with the adjusting means to correspond to the requirements of the terminals.
5. A system as claimed in claim 4, c h a r a c t e r i z e d in that it further comprises a control system (50) for electrically controlling the adjusting means (85).
6. A system as claimed in claim 5, c h a r a c t e r i z e d in that the

connection between the adjusting means (85) of the distribution tank and the control system (50) is a wireless data communication connection.

7. A system as claimed in any one of the preceding claims, characterized in that the second main pipe (100) comprises an isolation layer.

8. A system as claimed in any one of claims 1 to 5, characterized in that the pipework connected to the distribution tank comprises shutoff means.

9. A distribution tank for a low-energy network, characterized in that it comprises:

two reservoirs (82, 81), a first reservoir (81) and a second reservoir (82), of which the first distribution reservoir (81) is configured to receive and transfer heated transfer liquid, and the second distribution reservoir (82) is configured to receive and transfer cooled transfer liquid, the reservoirs (81, 82) comprising:

main pipe receiving means (110, 210) for receiving main pipes (100, 200) in the first and second distribution reservoirs (81, 82), respectively,

receiving means (11, 12) for pipeworks of ground circuits (1a, 1b) and/or a terminal (3) for receiving the pipeworks into a first and second space (81, 82), respectively.

10. A distribution tank as claimed in claim 9, characterized in that the first reservoir (81) and the second reservoir (82) are separated from each other with an isolation section (86).

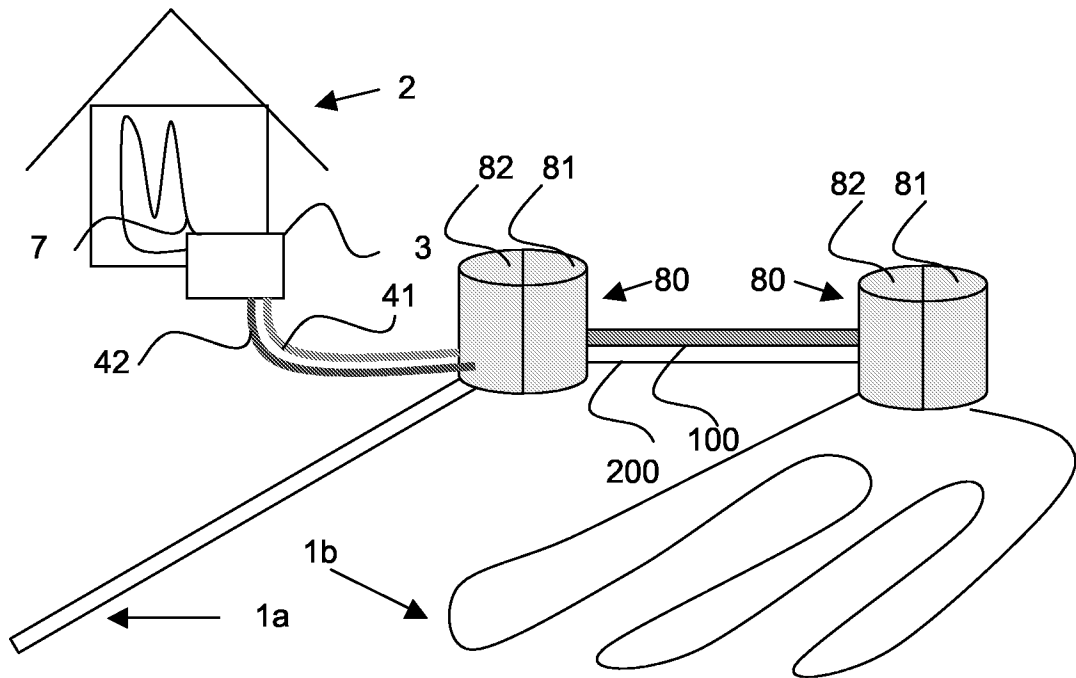

FIG. 1

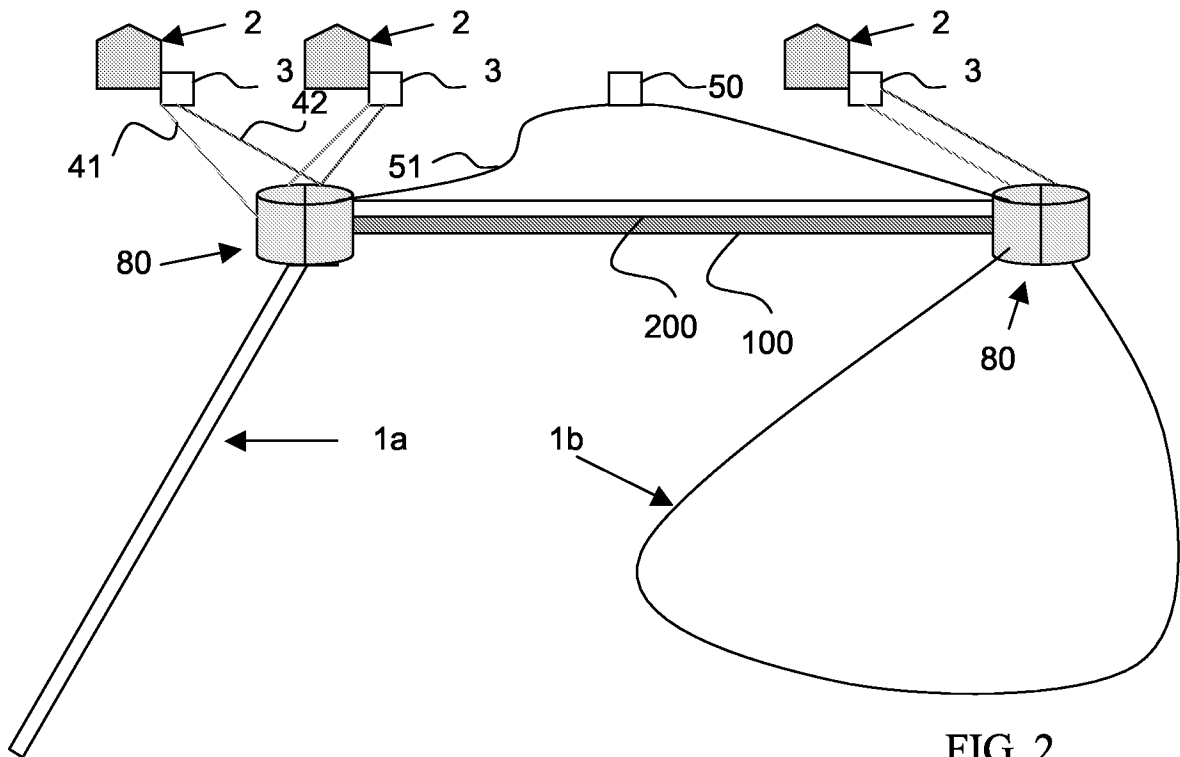

FIG. 2

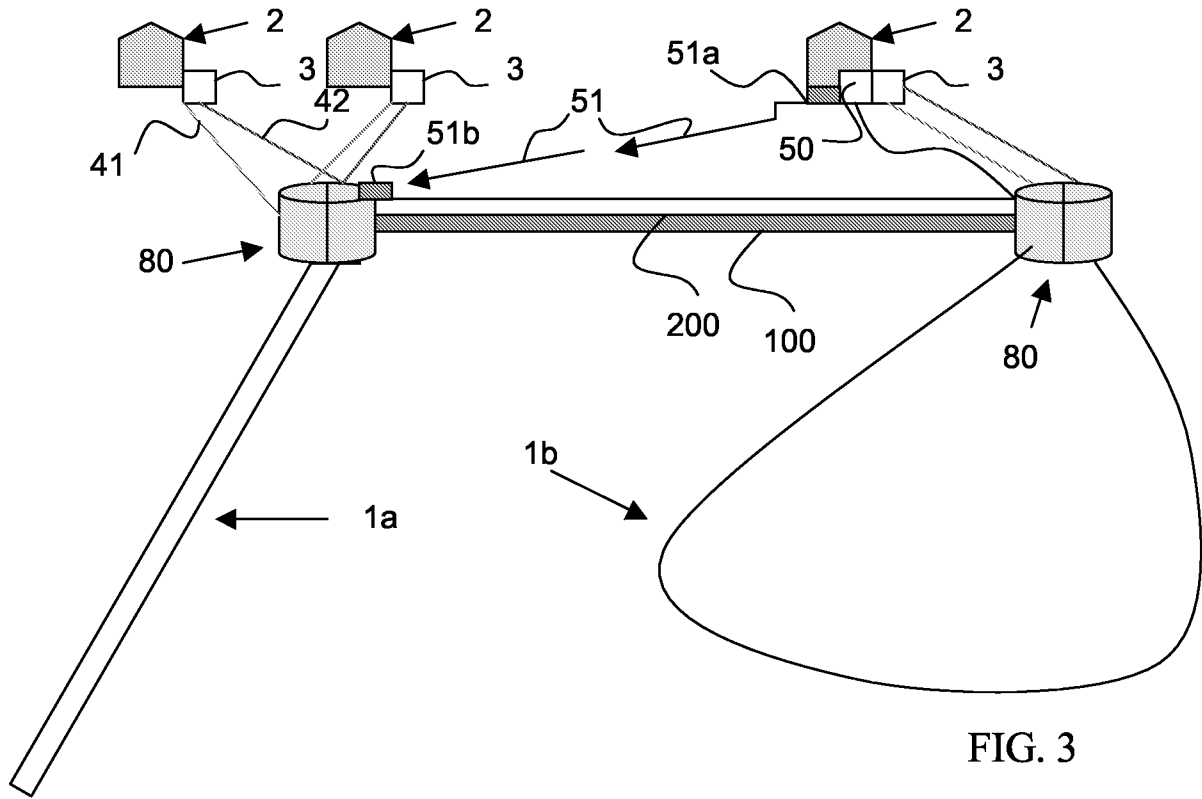

FIG. 3

3/5

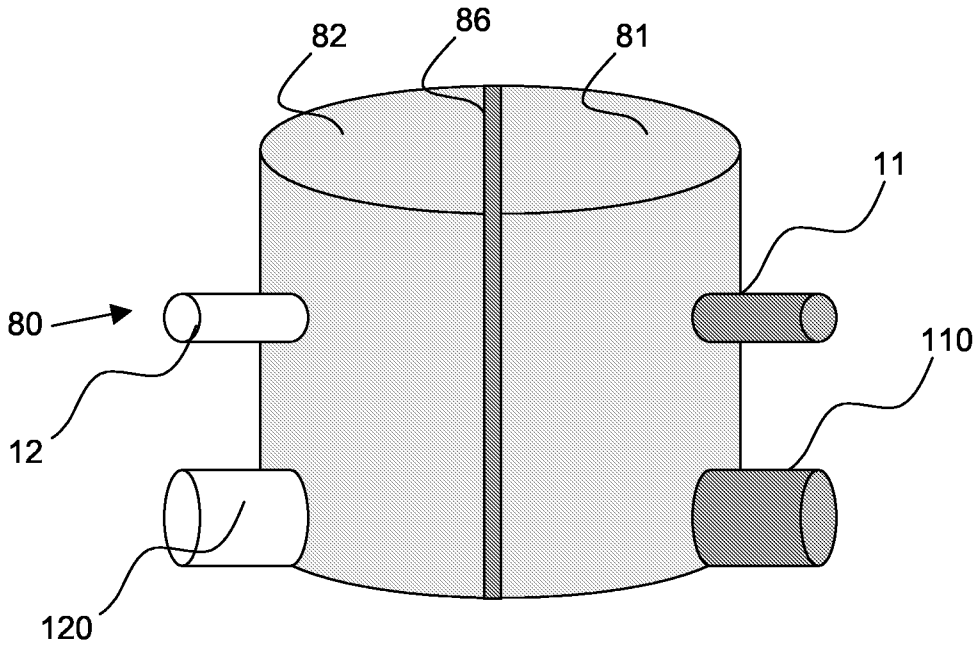

FIG. 4

4/5

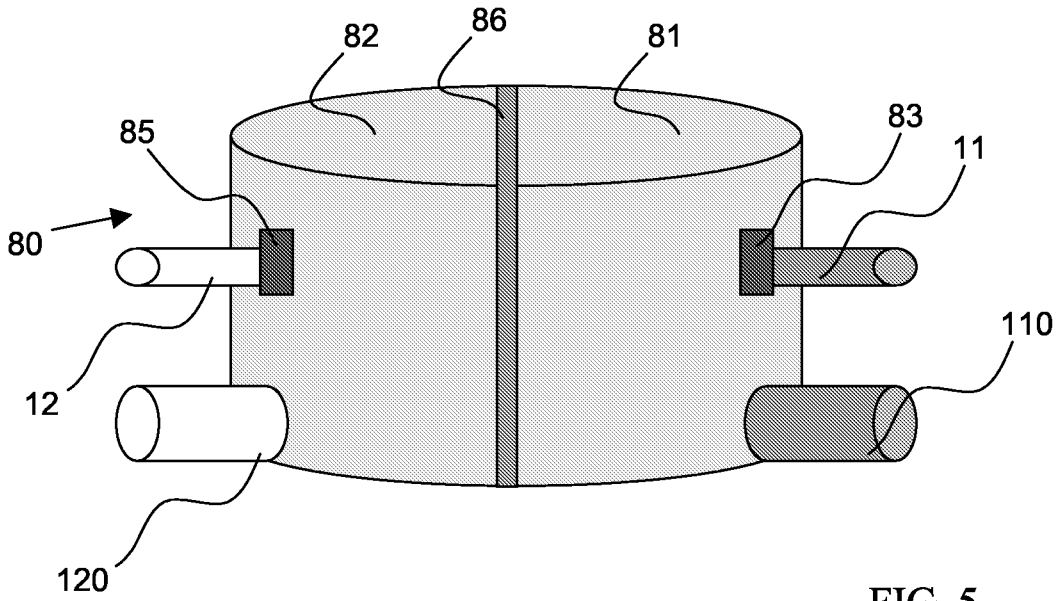

FIG. 5

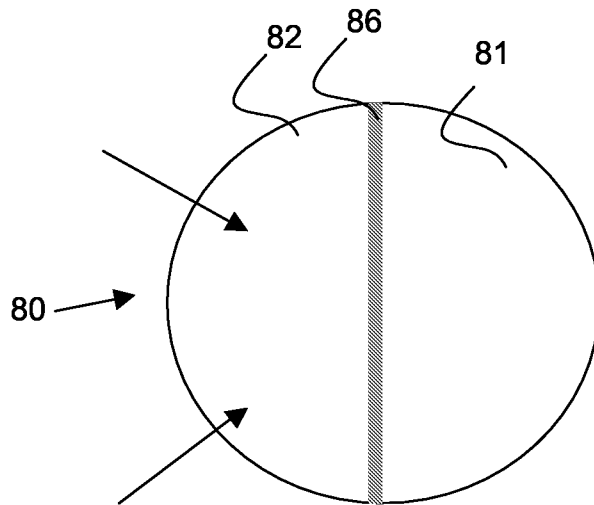

FIG. 6

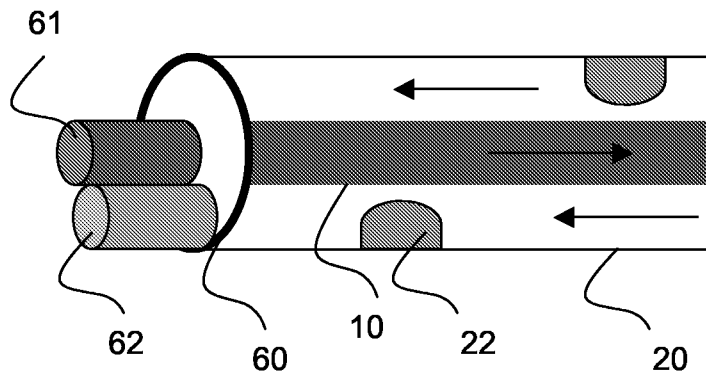

FIG. 7

## INTERNATIONAL SEARCH REPORT

International application No.

PCT/FI2007/050140

A. CLASSIFICATION OF SUBJECT MATTER See extra sheet According to International Patent Classification (IPC) or to both national classification and IPC		
B. FIELDS SEARCHED Minimum documentation searched (classification system followed by classification symbols) IPC8: F24J, F24D Documentation searched other than minimum documentation to the extent that such documents are included in the fields searched FI, SE, NO, DK Electronic data base consulted during the international search (name of data base and, where practicable, search terms used) EPO-INTERNAL, WPI		
C. DOCUMENTS CONSIDERED TO BE RELEVANT		
Category*	Citation of document, with indication, where appropriate, of the relevant passages	Relevant to claim No.
A	US 2005121169 A1 (MCNAIR EDWARD F) 09 June 2005 (09.06.2005), whole document	1 - 10
<input type="checkbox"/> Further documents are listed in the continuation of Box C. <input checked="" type="checkbox"/> See patent family annex.		
* Special categories of cited documents: "A" document defining the general state of the art which is not considered to be of particular relevance "E" earlier application or patent but published on or after the international filing date "L" document which may throw doubts on priority claim(s) or which is cited to establish the publication date of another citation or other special reason (as specified) "O" document referring to an oral disclosure, use, exhibition or other means "P" document published prior to the international filing date but later than the priority date claimed		"T" later document published after the international filing date or priority date and not in conflict with the application but cited to understand the principle or theory underlying the invention "X" document of particular relevance; the claimed invention cannot be considered novel or cannot be considered to involve an inventive step when the document is taken alone "Y" document of particular relevance; the claimed invention cannot be considered to involve an inventive step when the document is combined with one or more other such documents, such combination being obvious to a person skilled in the art "&" document member of the same patent family
Date of the actual completion of the international search 06 June 2007 (06.06.2007)		Date of mailing of the international search report 29 June 2007 (29.06.2007)
Name and mailing address of the ISA/FI National Board of Patents and Registration of Finland P.O. Box 1160, FI-00101 HELSINKI, Finland Facsimile No. +358 9 6939 5328		Authorized officer Raimo Herjo Telephone No. +358 9 6939 500

**INTERNATIONAL SEARCH REPORT**  
**Information on patent family members**

International application No.  
PCT/FI2007/050140

Patent document cited in search report	Publication date	Patent family members(s)	Publication date
US 2005121169 A1	09/06/2005	None	
.....			

INTERNATIONAL SEARCH REPORT

International application No.  
PCT/FI2007/050140

CLASSIFICATION OF SUBJECT MATTER

Int. Cl.

**F24J 3/08** (2006.01)

*F24D 15/04* (2006.01)