

(12) STANDARD PATENT
(19) AUSTRALIAN PATENT OFFICE

(11) Application No. **AU 2012202773 B1**

(54) Title
Videographic display of real-time medical treatment

(51) International Patent Classification(s)
G06T 9/20 (2006.01) **G06F 17/00** (2006.01)
A61B 6/00 (2006.01)

(21) Application No: **2012202773** (22) Date of Filing: **2012.05.11**

(30) Priority Data

(31) Number	(32) Date	(33) Country
13/462,750	2012.05.02	US

(43) Publication Date: **2013.09.19**

(43) Publication Journal Date: **2013.09.19**

(44) Accepted Journal Date: **2013.09.19**

(71) Applicant(s)
ViewRay Incorporated

(72) Inventor(s)
Dempsey, James F.

(74) Agent / Attorney
Pizzseys, PO Box 291, WODEN, ACT, 2606

(56) Related Art
US 2008/0033287
US 5391139
US 6512942

ABSTRACT

Systems and methods for creation of a videographic representation of a real-time medical treatment by a processor operating in conjunction with a treatment device and an imaging device are described. The representation may include real-time imaging data, a representation of real-time treatment data and contours of relevant anatomy among other things. Related systems and techniques are also described.

2012202773 11 May 2012

AUSTRALIA
Patents Act 1990

Regulation 3.2

Complete Specification
Standard Patent
Convention

APPLICANT: **ViewRay Incorporated**

Invention Title: **VIDEOGRAPHIC DISPLAY OF REAL-TIME
MEDICAL TREATMENT**

The following statement is a full description of this invention, including the best method of performing it known to me:

VIDEOGRAPHIC DISPLAY OF REAL-TIME MEDICAL TREATMENT

CROSS-REFERENCE TO RELATED APPLICATION

[0001] This application claims the benefit of priority to U.S. Utility Patent Application Serial No. 13/462,750, filed on May 2, 2012. Priority of the aforementioned filing date is hereby claimed and the disclosure of the patent application is hereby incorporated by reference in its entirety.

TECHNICAL FIELD

[0002] The present disclosure relates to systems and methods for creation of a videographic representation of a real-time medical treatment performed by a treatment device in conjunction with an imaging device.

BACKGROUND

[0003] During certain medical treatments, for example, surgery or radiation therapy, movement of portions of the body being treated can decrease the effectiveness of a treatment or even cause harmful results. For example, movement of a tumor during radiation therapy can cause the radiation beam to miss the tumor and hit healthy tissue. Thus, it would be advantageous to provide visual confirmation or documentation of medical treatments, so as to enable convenient assessment of treatment accuracy.

SUMMARY

[0004] Creation of a videographic display of a real-time treatment by a treatment device operating in conjunction with an imaging device is described. An initial image of a treatment region can be obtained. One or more contours of relevant anatomy

in the initial image can be provided for or calculated. Real-time images of the treatment region and real-time treatment data can be obtained during a medical treatment. One or more real-time contours of relevant anatomy in a plurality of the real-time images can be determined and a videographic display can be created. The videographic display can include the real time images, corresponding real-time contours and a representation of the real-time treatment data. Related apparatus, systems and techniques are also described.

[0005] In one aspect, real-time images of a treatment region can be obtained during a medical treatment. One or more real-time contours of relevant anatomy in a plurality of the real-time images can be determined. A videographic display of a plurality of the real-time images can be provided for. The videographic display can include the corresponding real-time contours and a representation of the real-time treatment data.

[0006] The real-time images can be obtained from a magnetic resonance imaging system and can be determined using deformable image registration. In one implementation, the medical treatment can be radiation therapy and the real time treatment data can comprise one or more of: firing status of one or more radiation beams of a radiation therapy device, location of one or more radiation beams, shape of one or more radiation beams, intensity of radiation associated with one or more radiation beams, and delivered radiation dose. The representation of the real-time treatment data in the videographic display can include one or more of: a graphical representation of a beam for one or more radiation beams when the one or more radiation beams are on, an indication of accumulated dose deposition, and textual indications of the amount of accumulated deposited dose.

[0007] Initial and real-time images can be obtained from one or more of: a magnetic resonance imaging system, a positron emission tomography scanner, a computed tomography scanner and an X-ray machine. The real-time contours can be determined using deformable image registration.

[0008] Real-time treatment data can comprise at least one of surgical instrument location information, surgical incision location information, a graphical representation of an instrument and a portion of a medical professional that can be captured in the real-time images. The videographic display can be provided on a remote device and can be three dimensional.

[0009] In another aspect, a system can comprise an imaging device, a treatment device, a display, and a processor. The imaging device can be configured to acquire real-time images of a treatment region during a medical treatment. The treatment device can be configured to acquire real-time treatment data during the medical treatment. The processor can be configured to determine real-time contours of relevant anatomy in a plurality of real-time images and to output to the display a videographic display of a plurality of the real-time images. The videographic display can include the corresponding real-time contours and a representation of the real-time treatment data.

[0010] The imaging device can be a magnetic resonance imaging system and the processor can determine the real-time contours using deformable image registration. The treatment device can be a radiation therapy device having one or more radiation beams and the real time treatment data comprising one or more of: firing status of one or more radiation beams, location of one or more radiation beams radiation beams, shape of one or more radiation beams, intensity of radiation associated with one or more radiation

beams, and delivered radiation dose. The representation of the real-time treatment data in the videographic display can include one or more of: a graphical representation of a beam for one or more radiation beams when the radiation beam is on, an indication of accumulated dose deposition, and textual indications of the amount of accumulated deposited dose.

[0011] The imaging device can be selected from: a magnetic resonance imaging system, a positron emission tomography scanner, a computed tomography scanner and an X-ray machine. The system can further comprise a second imaging device that can be configured to acquire a portion of the images of the treatment region.

[0012] The processor can determine the real-time contours using deformable image registration. The real-time treatment data can comprise at least one of surgical instrument location information, surgical incision location information, a graphical representation of at least one of an instrument that is captured in the real-time images and a portion of a medical professional that is captured in real-time images. The display can be on a remote device and can be three dimensional. The videographic display can be provided over a web interface to a social media site.

[0013] These and other features, aspects, and advantages of the present disclosure will become better understood with reference to the following description and claims.

BRIEF DESCRIPTION OF DRAWINGS

[0014] Features, aspects, and implementations of the disclosure are described in conjunction with the attached drawings, in which:

[0015] FIG. 1 is a simplified diagram illustrating aspects of a system consistent with implementations of the current subject matter;

[0016] FIG. 2 illustrates an example of a treatment device operating in conjunction with an exemplary imaging device;

[0017] FIG. 3 illustrates another example treatment device operating in conjunction with an exemplary imaging device;

[0018] FIG. 4 illustrates yet another example of treatment device operating in conjunction with an imaging device;

[0019] FIG. 5 is a simplified diagram illustrating aspects of a method consistent with implementations of the current subject matter; and

[0020] FIG. 6 illustrates a videographic display consistent with implementations of the current subject matter.

DETAILED DESCRIPTION

[0021] The subject matter described herein provides many advantages, some of which are noted below. The creation of a videographic display of real-time medical treatment allows visual documentation of the treatment to be shared with a doctor, patient, family member, caretaker, etc. The viewer will be able to see, via a videographic display, portions of the body that were treated, and the operation of a treatment device acting on those body portions to treat the patient (for example, incisions by a robotic surgery scalpel, radiation by a radiation therapy device, etc.). Accordingly, the videographic display can provide evidence of whether the patient was treated properly, thereby providing information and potential psychological satisfaction to the patient or other viewers. The videographic display can also be used to educate and to assess

whether additional treatments or medical-care may be required. Such real-time videographic display of treatment can also ensure efficiency amongst clinicians as their role in treatment can be recorded and shared with the patient and other individuals.

[0022] FIG. 1 is a simplified diagram illustrating aspects of a system 100 consistent with implementations of the current subject matter. The system 100 can include at least a treatment device 102, an imaging device 104, a processor 106, and a display 108. The treatment device 102 can be a radiation therapy device, one or more robotic surgery arms, one or more surgical scalpels, or any other suitable treatment devices, for example, high intensity focused ultrasound (HIFU) ablation devices, cryo-ablation devices, laser ablation devices, RF ablation devices, and catheters or other devices for delivering treatments such as brachytherapy, stents, embolic devices, vascular grafts, suture markers, and orthopedic devices including but not limited to screws and plates. The imaging device 104 can be a magnetic resonance imaging (MRI) system, a positron emission tomography (PET) scanner, a computed tomography (CT) scanner, an X-ray machine, other imaging devices or a combination of imaging devices. The processor 106 can include a computer that includes at least one microprocessor and a machine-readable medium that can store instructions, or the processor may comprise any other computer components configured to implement the systems and methods of the present disclosure. The display 108 can include a terminal device, such as a desktop computer, laptop, tablet computer, cellular phone, television, holograph generator or any other display medium. In some implementations, the terminal device can be a remote device, remote from the treatment device 102 and the imaging device 104. Each of the arrows 110, 112, and 114 can separately characterize either a wired or wireless

connection, such as cellular network, internet, local area network, or wide area network, and each connection may include multiple connections and may pass through and interact with additional elements such as servers, cloud computing devices and the like. Real-time treatment data passes over connection 110 from the treatment device 102 to the processor 106 and real-time image data passes through connection 112 from imaging device 104 to processor 106. Information required to create a videographic display travels across connection 114 from the processor 106 to the display 108.

[0023] FIG. 2 illustrates an example of a treatment device 102 operating in conjunction with an imaging device 104 as described in the present disclosure. The treatment device 102 in this example is a radiation therapy device 206 mounted on a rotatable gantry 216. The imaging device 104 in this example is a magnetic resonance imaging (MRI) system 208. Radiation therapy device 206 can include one or more radiation beam sources, such as a cobalt-60 source or a linear accelerator, which can be controlled to transmit radiation to a predetermined anatomy of a patient 212. The radiation therapy device 206 can further include one or more multi-leaf collimators to shape the radiation beams transmitted to patient 212. The radiation beam or beams may thus be turned on and off, can be rotated on the gantry 116, and can have their shape and intensity modified by multi-leaf collimators or other devices.

[0024] FIG. 3 illustrates an additional example of a treatment device 102 operating in conjunction with an imaging device 104 as described in the present disclosure. The treatment device 102 in this example is a robotic surgery device 306. The imaging device 104 in this example is a magnetic resonance imaging (MRI) system

308. The robotic surgery device 306 can be controlled to move with respect to the body of a patient 310 so as to operate on the patient 310.

[0025] FIG. 4 illustrates an additional example of a treatment device 102 operating in conjunction with an imaging device 104 as described in the present disclosure. The treatment device 102 in this example is a surgical scalpel 406. The imaging device 104 in this example is a magnetic resonance imaging (MRI) system 412. Surgical scalpel 406 can be configured to be used by a clinician 408 on a portion of the body of patient 410 to perform a surgical procedure.

[0026] Further details regarding the exemplary implementations of FIGS. 2-4 will be understood with reference to the below explanation of an exemplary method of the present disclosure.

[0027] FIG. 5 is a simplified diagram illustrating aspects of an exemplary process 500 that may be used to implement the method of the present disclosure. For example, an initial image of a treatment region may be obtained from imaging device 104 at 502. One or more contours of relevant anatomy may then be provided or calculated in the initial image at 504. As an example, contours may include the boundaries of a tumor to be treated and also the boundaries of nearby anatomy that must be avoided in the treatment. These contours may be developed manually by a clinician. In an alternate implementation, the contours can be developed using automated computer programs.

[0028] After the medical treatment begins, real-time image data from the treatment region can be obtained using imaging device 104 at 506. Additionally, real-time treatment data can be obtained from treatment device 102 at 508.

[0029] Real-time treatment data for the implementation depicted in FIG. 2 (wherein treatment device 102 is a radiation therapy device 206) may include one or more of: the firing status of the one or more radiation beams, the angular location of the beam(s), the shape of the beam(s), the intensity of radiation associated with the beam(s), the delivered radiation dose, and the like. Such treatment data can be acquired through, for example, sensors associated with the radiation source, the rotatable gantry, the leaves on the multi-leaf collimator(s), and the control system of the radiation therapy device. Treatment data could also be gathered from the imaging device 102 itself. Other data could be gathered as well, as would be understood by those skilled in the art.

[0030] Real-time treatment data for the implementation depicted in FIG. 3 (wherein treatment device 102 is a robotic surgery device 306) may include one or more of: the location and trajectory of the robotic surgery device 306, coordinates (for example, Cartesian coordinates, spherical coordinates, or cylindrical coordinates) of the incision into the body of the patient 310, the shape of the operative implement of robotic surgery device 306, audio and/or visual recordings of one or more clinicians involved in the surgery, and the like. Such treatment data can be acquired through, for example, sensors associated with the robotic surgery device 306 to record its trajectory, location or change in shape or a graphic or videographic camera or other imaging modality used in conjunction with the robotic surgery device 306. Treatment data could also be gathered from the imaging device 102 as well. Other data could be gathered as well, as would be understood by those skilled in the art.

[0031] Real-time treatment data for the implementation depicted in FIG. 4 (wherein treatment device 102 is a surgical scalpel 406) may include one or more of: the

location and trajectory of the surgical scalpel 406, coordinates (for example, Cartesian coordinates, spherical coordinates, or cylindrical coordinates) of the incision into the body of the patient 416, audio and/or visual recordings of one or more clinicians involved in the surgery, and the like. Such treatment data can be acquired through, for example, sensors associated with the surgical scalpel 406 to record its trajectory or location or a graphic or videographic camera or other imaging modality used in conjunction with the surgical scalpel 406. Treatment data could also be gathered from the imaging device 102 as well. Other data could be gathered as well, as would be understood by those skilled in the art.

[0032] At 510 in FIG. 5, real-time contours of the relevant anatomy in the real-time images may be determined. The real-time contours can be determined using deformable image registration and the initial image and contours acquired in 502 and 504, as well as with real-time images and contours. Contours may also be developed using other image processing techniques individually or in combination, such as, edge detection, pattern recognition, and the like.

[0033] A videographic display of a plurality of the real-time images can be created at 512 in FIG. 5. The display can include the corresponding real-time contours of the plurality of the real-time images and a representation of the real-time treatment data. Display 108 may be a terminal device, such as a desktop computer, laptop, tablet computer, cellular phone, television, holograph generator or any device capable of displaying a video. The display 108 may be located with the treatment device 102 and imaging device 104 or it may be remote from that location. As previously mentioned, the videographic display may utilize a wired connection or a wireless connection, such as

cellular network, internet, local area network, wide area network, metropolitan area network, Bluetooth network, infrared network, Zigbee wireless network, Wibree network, and the like, and each connection may include multiple connections and may pass through and interact with additional elements such as servers and cloud computing devices. In one example, the videographic display may be provided over a web interface to a site such as a social media site where individuals can post, share and comment on various documented medical treatments.

[0034] In one implementation, the components of the treatment data and image data can be assembled together at the processor 106 such that a videographic file can be sent to display 108. In an alternate implementation, the components of the treatment data and image data can be sent separately from the processor 106 to display 108 where the separately received components can be assembled to form the videographic display. The assembly can be performed based upon selections by a viewer of the videographic display.

[0035] In one implementation, acquired treatment data can be overlaid on respective real-time images to form a set of final images, and then images of the set can be combined to form the videographic display. This overlaying can be performed using a correlation, in time and space, of treatment data and corresponding image data.

[0036] At least a portion (for example, a predetermined number) of images of the set of final image data may be combined to form the videographic display. The predetermined number can vary depending factors such as, the communication channel utilized (for example, direct wire connection, cellular network, internet, local area network, wide area network, metropolitan area network, Bluetooth network, etc.), the

available bandwidth of the communication channel, the display type (for example, laptop, desktop computer, tablet computer, cellular phone, wireless device) and other factors. In one example, the predetermined number when the display 108 is a mobile phone can be lower than the predetermined number when the display 108 is a high processing capability computer. In some implementations, the predetermined number can be determined by a clinician based on a personal preference of the clinician or the patient.

[0037] FIG. 6 illustrates one example of a videographic display 600 that can be created utilizing the method of the present disclosure and the particular treatment device of a radiation therapy device. It is understood that numerous other types of displays can be created based upon the teachings herein. The videographic display 600 can include a graphic or videographic representation of anatomy 602 of a patient. In the example of FIG. 6, the anatomy 602 includes the lungs, heart, spine and abdomen. The anatomy 602 can also include, for example, a tumor 603 that is being treated.

[0038] The videographic display 600 may be two or three dimensional. In one implementation, the multidimensional data in videographic display 600 can be a combination of the data obtained by the processor 106 from the imaging device 104 and treatment device 102. The two dimensional image data for different orientations of the patient can be obtained by processor 106 from the imaging device 104 and treatment device 102, and this two dimensional data can be combined to form the three dimensional data. The combining may be performed using reconstruction algorithms, such as three-dimensional reconstruction, triangulation, and the like. Some such reconstruction algorithms can involve at least one of: matching pixels in different 2D images, sampling a 3D space, determining a consistency function that correlates (based on variance,

covariance, and the like statistical techniques) one or more image parameters (for example, color, anatomical texture, and the like), mapping each pixel in each 2D image to a vector in 3D, and like techniques. When the videographic display 600 has more than two dimensions, a button such as 604 can be provided that can be pressed by a user to view the treatment from different angles; alternatively, a swipe on a touch screen could perform the same function. In one implementation, a user can zoom in or out of the multidimensional display with buttons such as 606 and 608.

[0039] Real-time contours enclosing different anatomical structures or other areas such as a region of anatomy targeted for treatment may be included in the videographic display. Contours may be represented in different colors. For example, the display may include a contour 610 around tumor 603, which may red in color while neighboring structures may be enclosed by a blue contour. Various structures may also include internal shading if desired, which may be partially translucent. In the example where the treatment device 102 is a radiation therapy device, the display may include an additional contour 612 representing the location of the planned treatment beam (which typically extends up to some distance outside of the tumor 603).

[0040] In one implementation, the videographic display 600 can include an option through which a user can select the contours that the user (for example, a clinician or a user of display 108) may desire to view. For example, if the user desires to view only the contour for the tumor, the user can select just that contour.

[0041] Treatment data may be included in videographic display 600. For example, as shown in the FIG. 6 example utilizing a radiation treatment device, beam representations 614 can be included. The beam representations may turn on and off or

change shape or angle or intensity as the video progresses, corresponding to the operation of the actual beams during treatment (as determined by the acquired real-time treatment data). The treatment data can be made translucent so that the real-time image data is still visible. This representation of the beams may depict the beams turning on and off in line with the planned treatment regimen, and they may depict turning on and off as a result of the target tumor 603 moving beyond the contour 612 that represents the location of the planned treatment beam (as may occur as a result of patient motion or normal organ motion). The radiation beam treatment data may be depicted in numerous other ways. Another example representation of treatment data includes an indication of accumulated dose deposition. For example, as dose accumulates over the course of the treatment, the region in which the dose is deposited may turn darker in color.

[0042] The videographic display 600 may also include an information display 622 for displaying additional data such as a patient identifier (ID), the color of various contours, and additional treatment data. Examples of additional treatment data include total deposited dose, treatment time, beam on time, etc. In some implementations, the amount of dose deposited can vary in real-time as the amount increases during the treatment.

[0043] Other treatment data can be included in videographic display 600 when other treatment devices are used. For example, when treatment device 102 is a robotic surgery arm 306 or surgery scalpel 406, a representation of the scalpel or surgery device can be depicted. Alternatively, a representation of where an incision is taking place can be depicted or the representation of treatment data may simply be visible from the imaging data itself. The display may also be configured to depict all or a portion of a

medical professional performing the treatment. Numerous other types of treatment data or combinations of treatment data and other data can be depicted. In some implementations, the user can be provided an option to select which set of treatment data the user desires to view and also to select whether or not to depict any other data or even the imaging data.

[0044] Although a few implementations have been described in detail above, other modifications are possible. For example, the method depicted in FIG. 5 and described herein may not require the particular order shown, or sequential order, to achieve desirable results.

[0045] While various implementations in accordance with the disclosed principles have been described above, it should be understood that they have been presented by way of example only, and are not limiting. Thus, the breadth and scope of the invention(s) should not be limited by any of the above-described exemplary implementations, but should be defined only in accordance with the claims and their equivalents issuing from this disclosure. The present disclosure contemplates that the calculations disclosed in the implementations herein may be performed in a number of ways, applying the same concepts taught herein, and that such calculations are equivalent to the implementations disclosed. Furthermore, the above described advantages are not intended to limit the application of any issued claims to processes and structures accomplishing any or all of the advantages.

[0046] Additionally, section headings shall not limit or characterize the invention(s) set out in any claims that may issue from this disclosure. Specifically, and by way of example, although the headings refer to a "Technical Field," such claims

should not be limited by the language chosen under this heading to describe the so-called technical field. Further, the description of a technology in the "Background" is not to be construed as an admission that technology is prior art to any invention(s) in this disclosure. Neither is the "Summary" to be considered as a characterization of the invention(s) set forth in issued claims. Furthermore, any reference to this disclosure in general or use of the word "invention" in the singular is not intended to imply any limitation on the scope of the claims set forth below. Multiple inventions may be set forth according to the limitations of the multiple claims issuing from this disclosure, and such claims accordingly define the invention(s), and their equivalents, that are protected thereby.

[0047] Throughout this specification and the claims which follow, unless the context requires otherwise, the word "comprise", and variations such as "comprises" and "comprising", will be understood to imply the inclusion of a stated integer or step or group of integers or steps but not the exclusion of any other integer or step or group of integers or steps.

[0048] The reference to any prior art in this specification is not, and should not be taken as, an acknowledgement or any form of suggestion that the prior art forms part of the common general knowledge in Australia.

WHAT IS CLAIMED IS:

1. A method comprising:
 - delivering one or more radiation beams of ionizing radiation from one or more external radioisotope sources of an irradiating device controlled by a radiation treatment system to a treatment region according to a planned treatment regimen;
 - obtaining a plurality of real-time images of the treatment region using an imaging device controlled by the radiation treatment system while delivering of the one or more radiation beams;
 - obtaining real-time treatment data during the delivery of the one or more radiation beams, wherein the real time treatment data comprises one or more of: firing status of the one or more radiation beams, location of the one or more radiation beams, shape of the one or more radiation beams, intensity of radiation associated with the one or more radiation beams, and delivered radiation dose;
 - determining one or more real-time contours of relevant anatomy in the plurality of the real-time images using an image processing technique;
 - providing for a videographic display of one or more of the plurality of the real-time images, the videographic display including one or more corresponding real-time contours and a representation of the real-time treatment data.
2. The method of claim 1, wherein the imaging device is a magnetic resonance imaging system.
3. The method of claim 2, wherein the image processing technique is deformable image registration.
4. The method of claim 1, wherein the representation of the real-time treatment data in the videographic display includes one or more of: a graphical representation of a beam for the one or more radiation beams when the one or more radiation beams are on, an indication of accumulated dose deposition, and textual indications of the amount of accumulated deposited dose.

5. The method of claim 1, wherein initial images and the plurality of real-time images are obtained from one or more of: a magnetic resonance imaging system, a positron emission tomography scanner, a computed tomography scanner and an X-ray machine.

6. The method of claim 5, wherein the image processing technique is deformable image registration.

7. The method of claim 1, wherein the real-time treatment data further comprises at least one of surgical instrument location information and surgical incision location information.

8. The method of claim 1, wherein the real-time treatment data further comprises at least one of a graphical representation of an instrument and a portion of a medical professional that is captured in the real-time images.

9. The method of claim 1, wherein the videographic display is provided on a remote device.

10. The method of claim 1, wherein the videographic display is three dimensional.

11. A system comprising:

an irradiating device configured to deliver to a treatment region one or more radiation beams of ionizing radiation from one or more external radioisotope sources of the irradiating device according to a planned treatment regimen, the irradiating device further configured to acquire real-time treatment data during the delivery of the one or more radiation beams,

wherein the real time treatment data comprises one or more of: firing status of the one or more radiation beams, location of the one or more radiation beams, shape of the one or more radiation beams, intensity of radiation associated with the one or more radiation beams, and delivered radiation dose;

an imaging device configured to acquire a plurality of real-time images of the treatment region during the delivery of the one or more radiation beams;

a display; and,

a processor configured to determine one or more real-time contours of relevant anatomy in the plurality of the real-time images using an image processing technique and to output to the display a videographic display of the plurality of the real-time images, the videographic display including the one or more real-time contours and a representation of the real-time treatment data.

12. The system of claim 11, wherein the imaging device is a magnetic resonance imaging system.

13. The system of claim 12, wherein the image processing technique is deformable image registration.

14. The system of claim 11, wherein the representation of the real-time treatment data in the videographic display includes one or more of: a graphical representation of a beam for the one or more radiation beams when the radiation beam is on, an indication of accumulated dose deposition, and textual indications of the amount of accumulated deposited dose.

15. The system of claim 11, wherein the imaging device is selected from: a magnetic resonance imaging system, a positron emission tomography scanner, a computed tomography scanner and an X-ray machine

16. The system of claim 15, further comprising a second imaging device configured to acquire a portion of the images of the treatment region.

17. The system of claim 11, wherein the real-time treatment data further comprises at least one of surgical instrument location information and surgical incision location information.

18. The system of claim 11, wherein the real-time treatment data further comprises a graphical representation of at least one of an instrument that is captured in the real-time images and a portion of a medical professional that is captured in the real-time images.

19. The system of claim 11, wherein the display is on a remote device.

20. The system of claim 11, wherein the videographic display is provided over a web interface to a social media site.

21. The system of claim 11, wherein the videographic display is three dimensional.

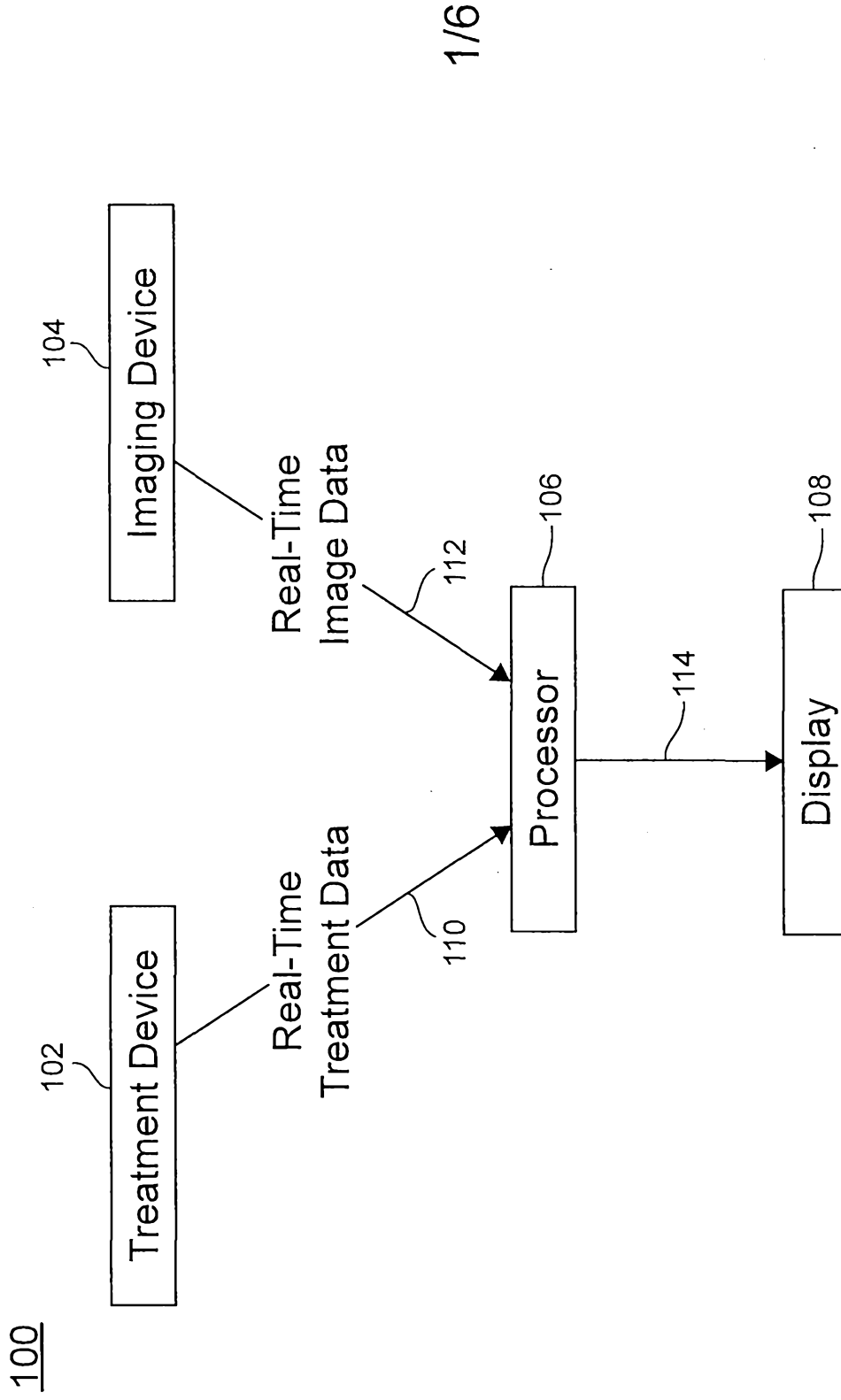

FIG. 1

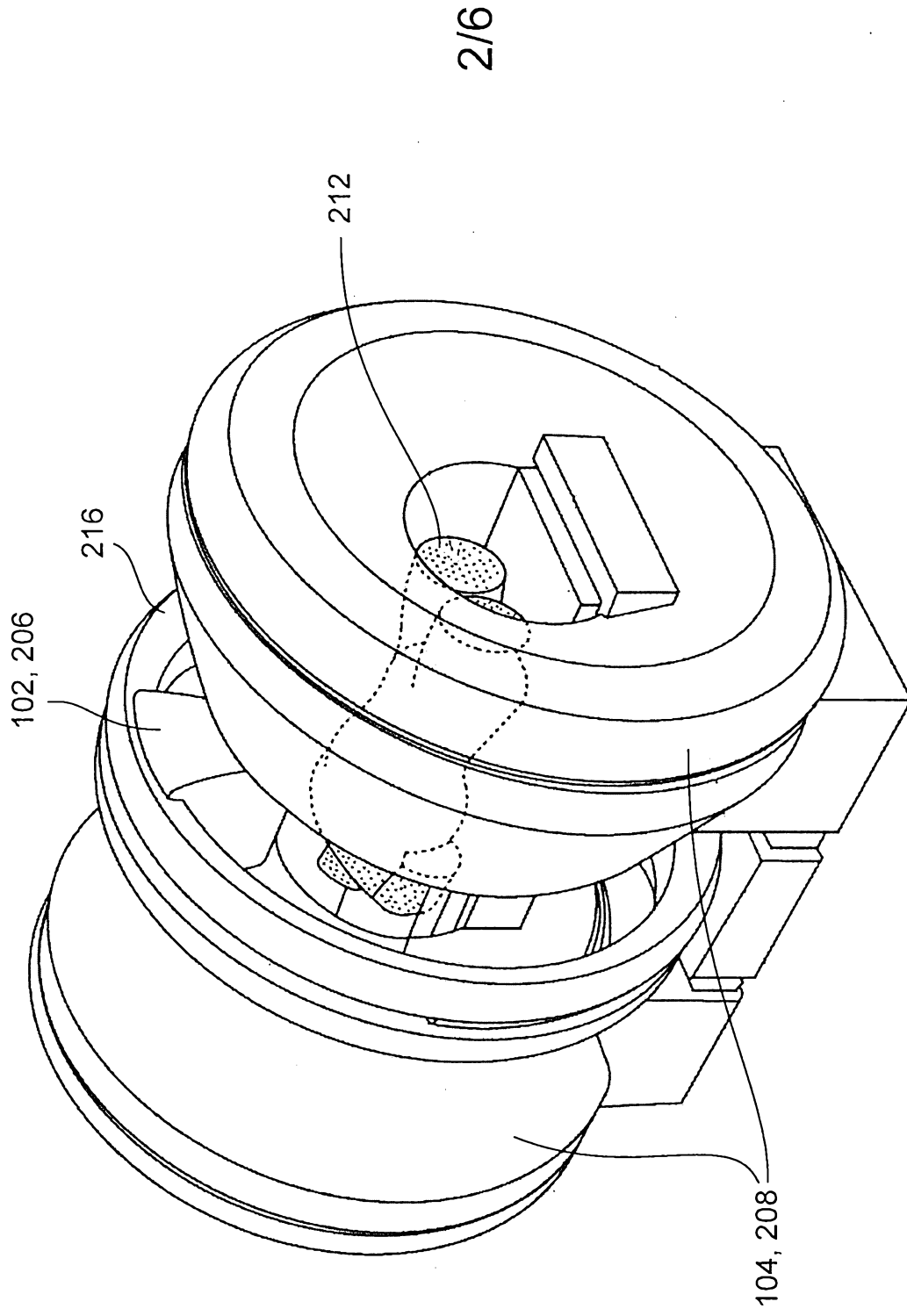

FIG. 2

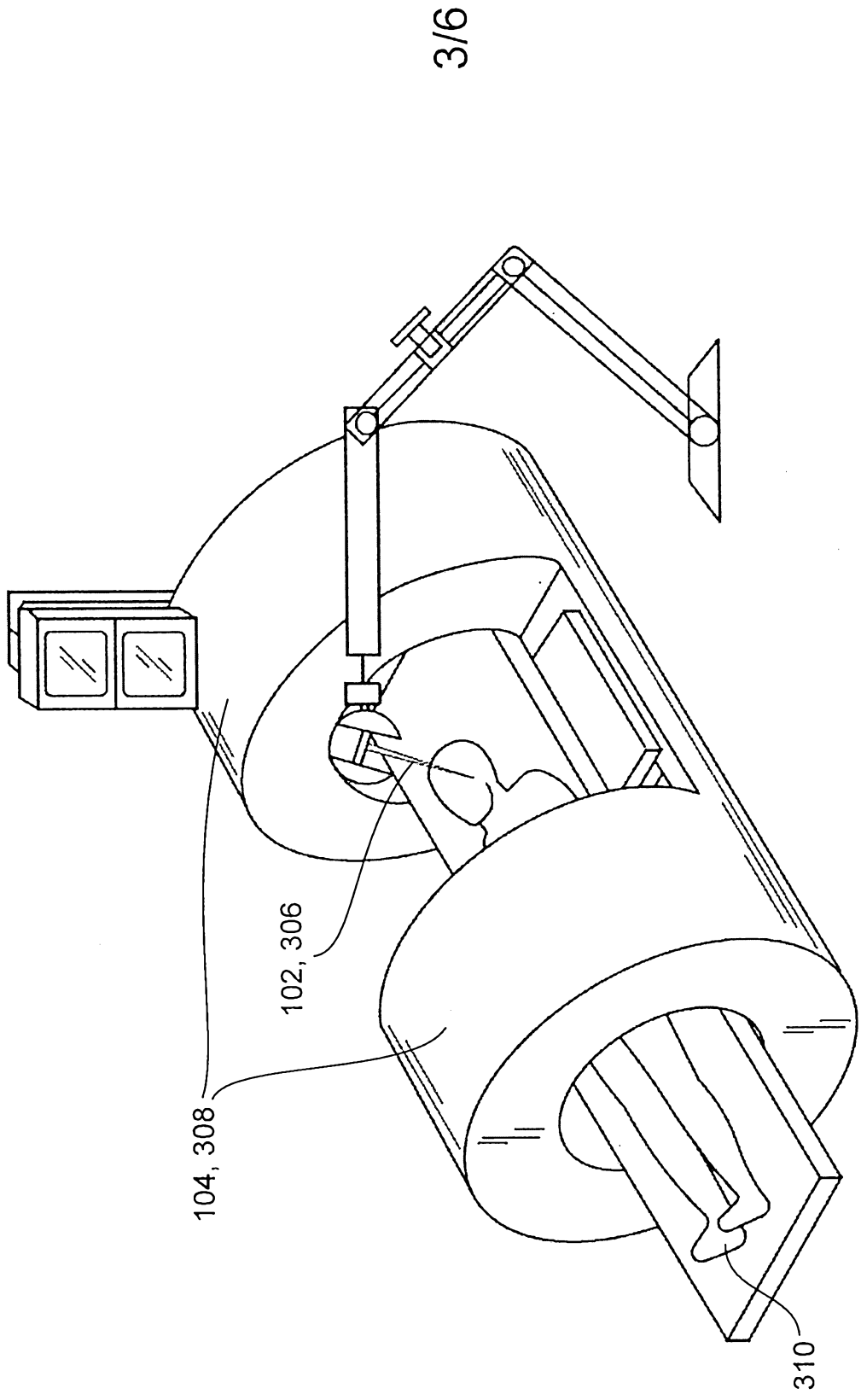

FIG. 3

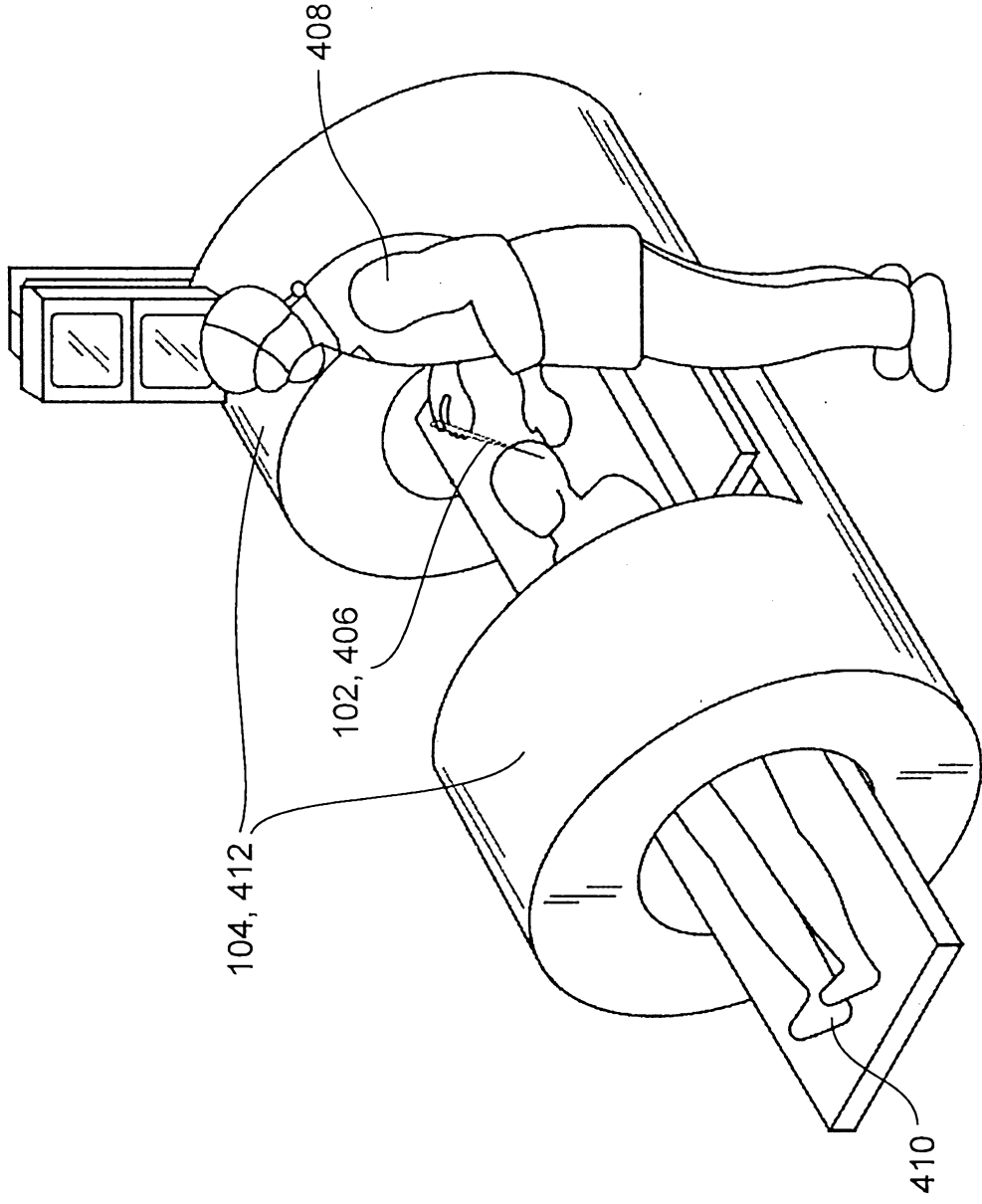

FIG. 4

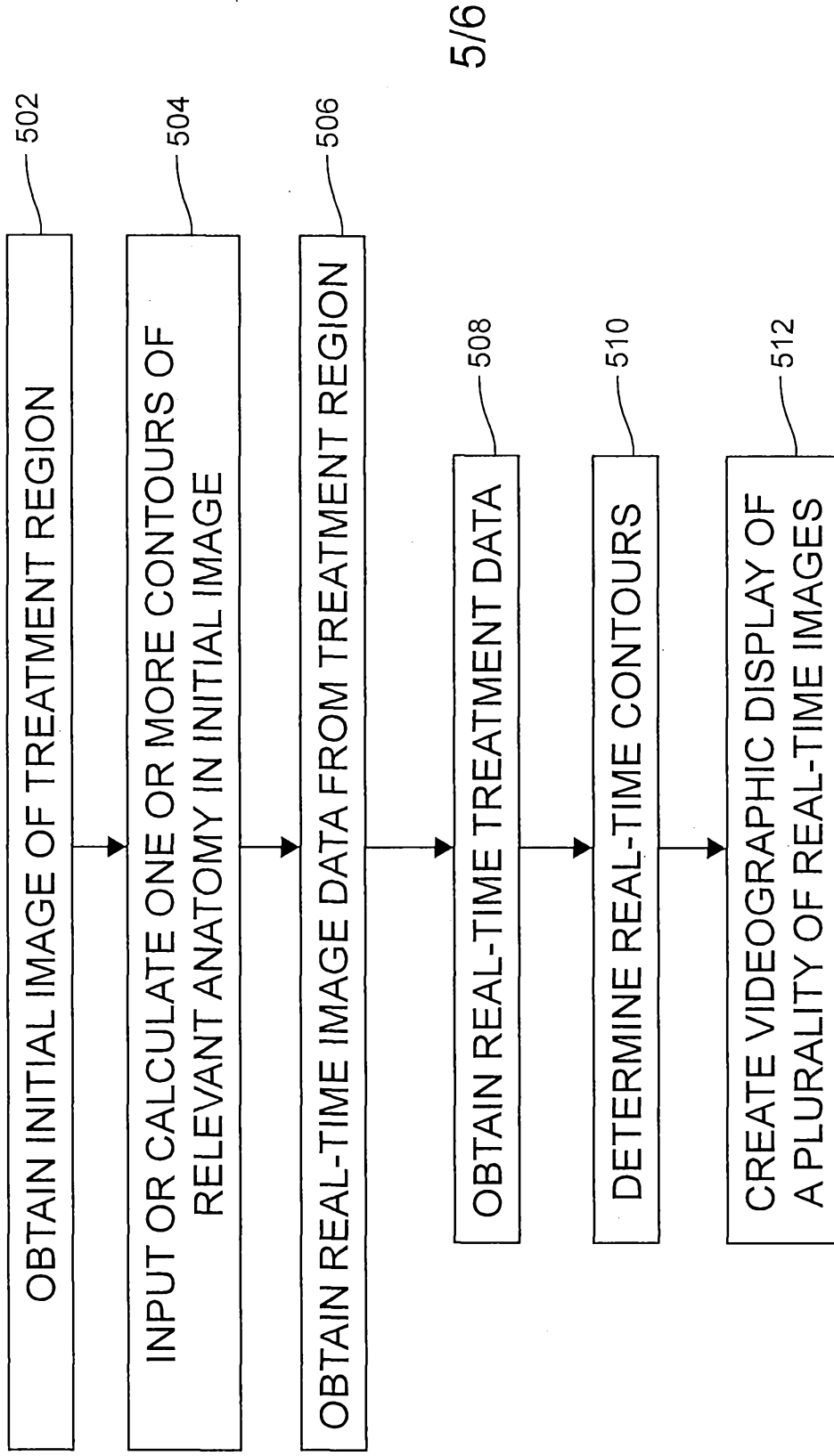

FIG. 5

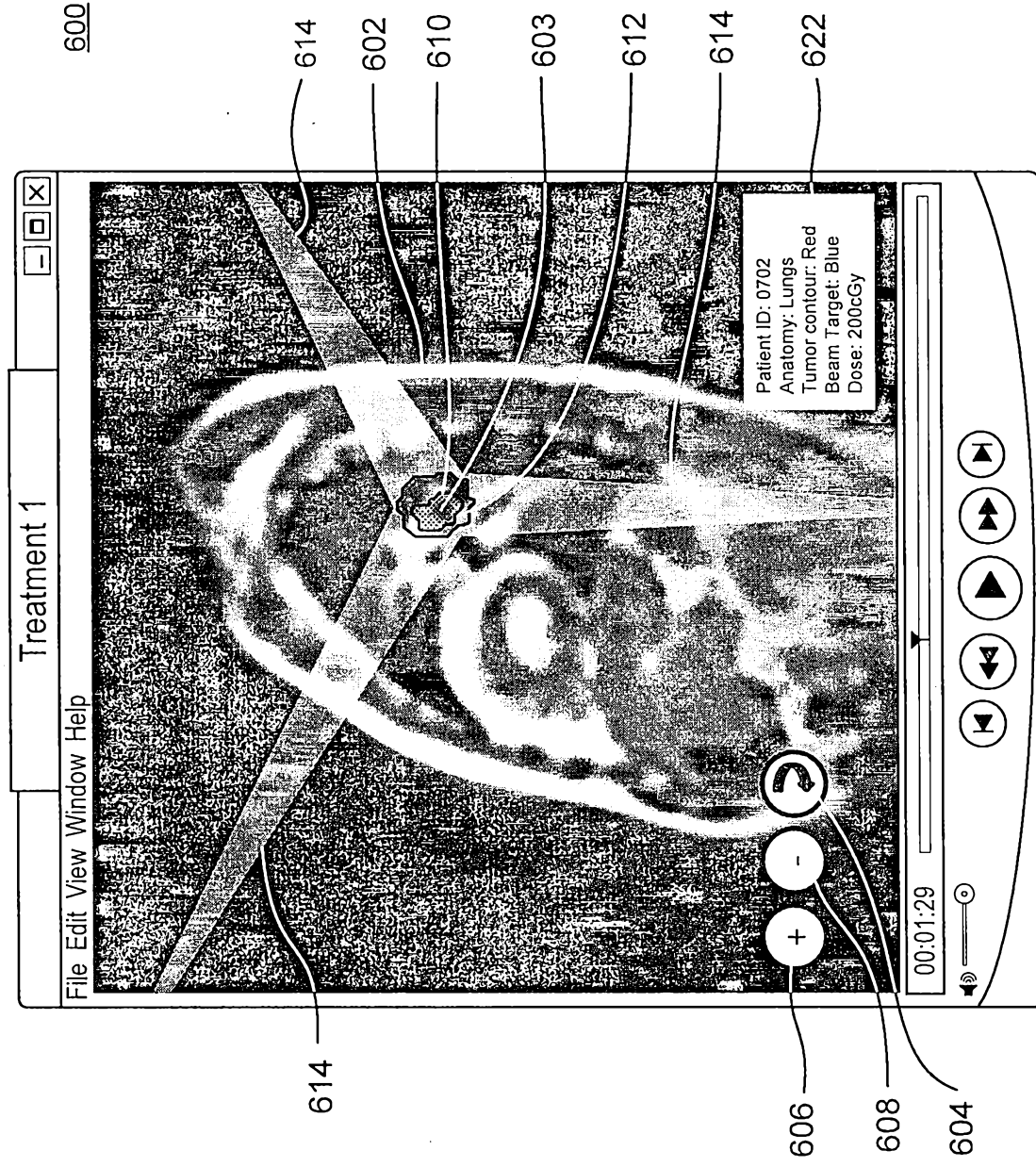

FIG. 6