



US 20060232670A1

(19) **United States**

(12) **Patent Application Publication**
Chu

(10) **Pub. No.: US 2006/0232670 A1**

(43) **Pub. Date: Oct. 19, 2006**

(54) **VEHICLE MONITORING APPARATUS**

(52) **U.S. CL. 348/118; 348/148**

(76) **Inventor: Fu-Lai Chu, Taichung Hsien (TW)**

Correspondence Address:
CHARLES E. BAXLEY, ESQUIRE
SUITE 309
90 JOHN STREET
NEW YORK, NY 10038 (US)

(57) **ABSTRACT**

(21) **Appl. No.: 10/968,557**

(22) **Filed: Oct. 19, 2004**

Publication Classification

(51) **Int. Cl.**
H04N 7/18 (2006.01)
H04N 9/47 (2006.01)

A vehicle monitoring device includes an image taking device having a housing for attaching to a vehicle, a motor disposed in the housing and having a spindle, a follower attached to the spindle and arranged to be rotated and driven by the motor and having a compartment. A video camera is attached to the follower, and rotated in concert with the follower. Another motor is disposed in the compartment of the follower and coupled to the video camera with such as a rack-and-pinion coupling, to rotate and adjust the video camera relative to the follower to different angular directions. A wiper may be attached to the housing, for wiping and cleaning a cap of the housing.

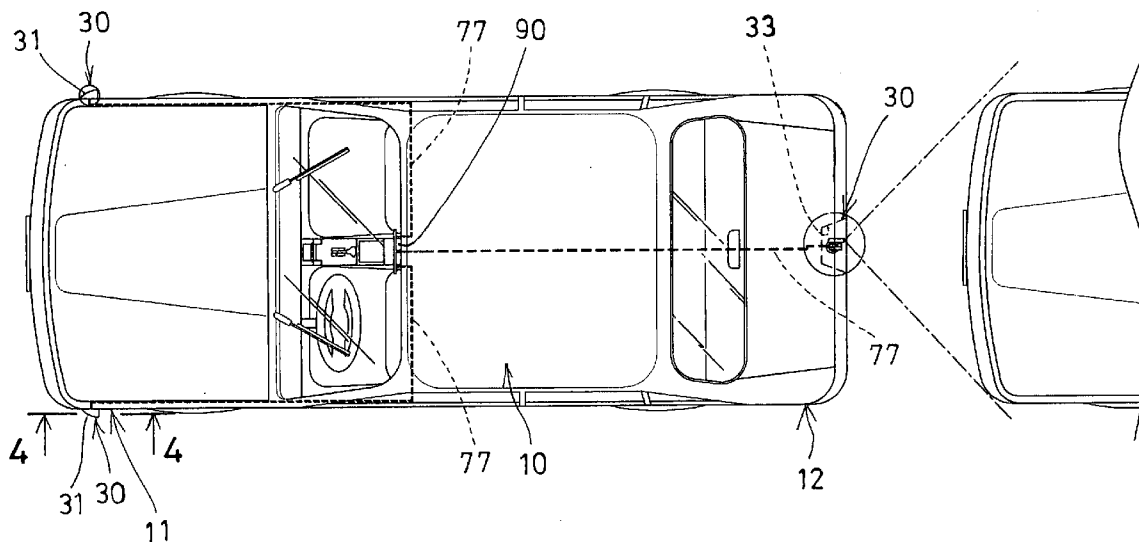

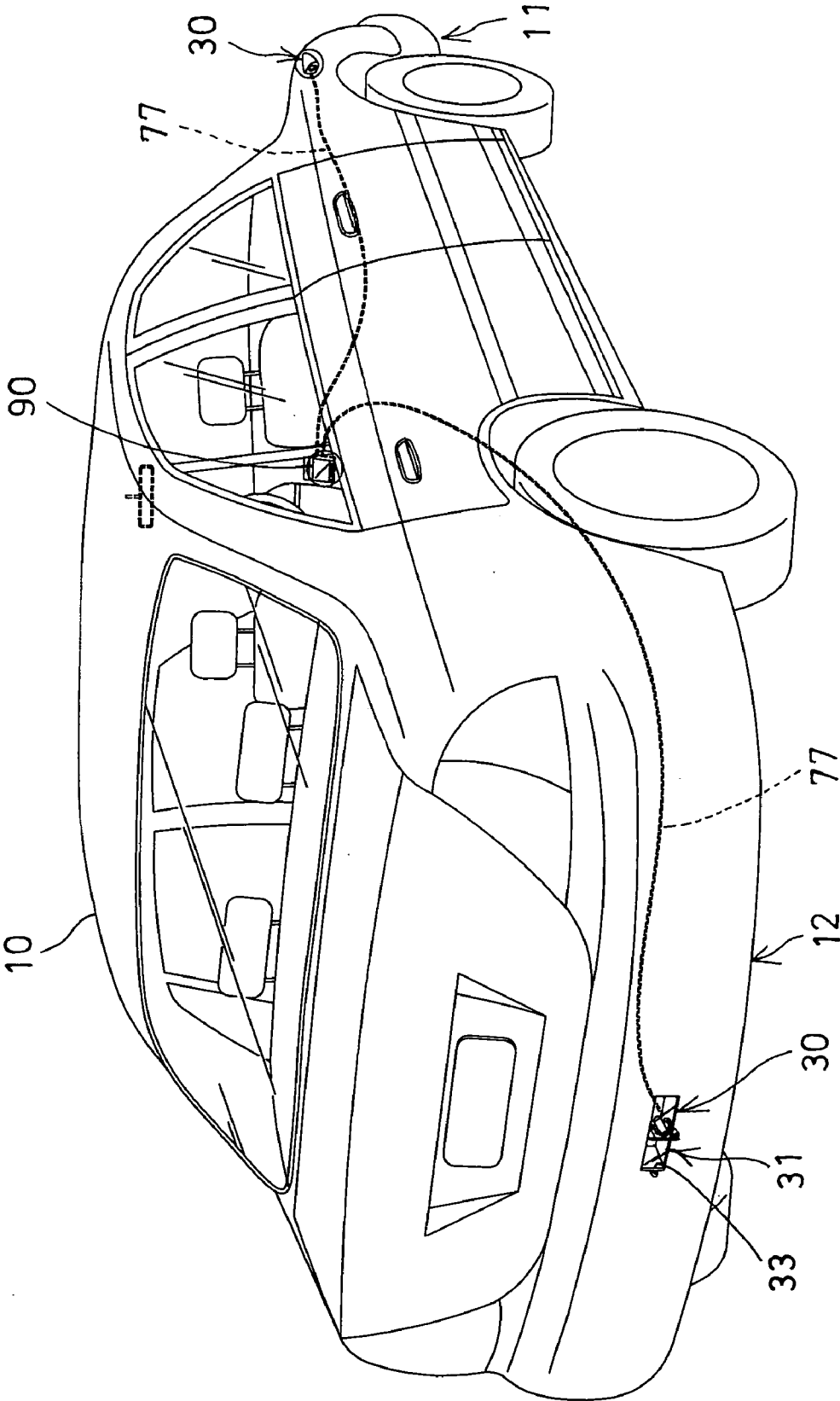

FIG. 1

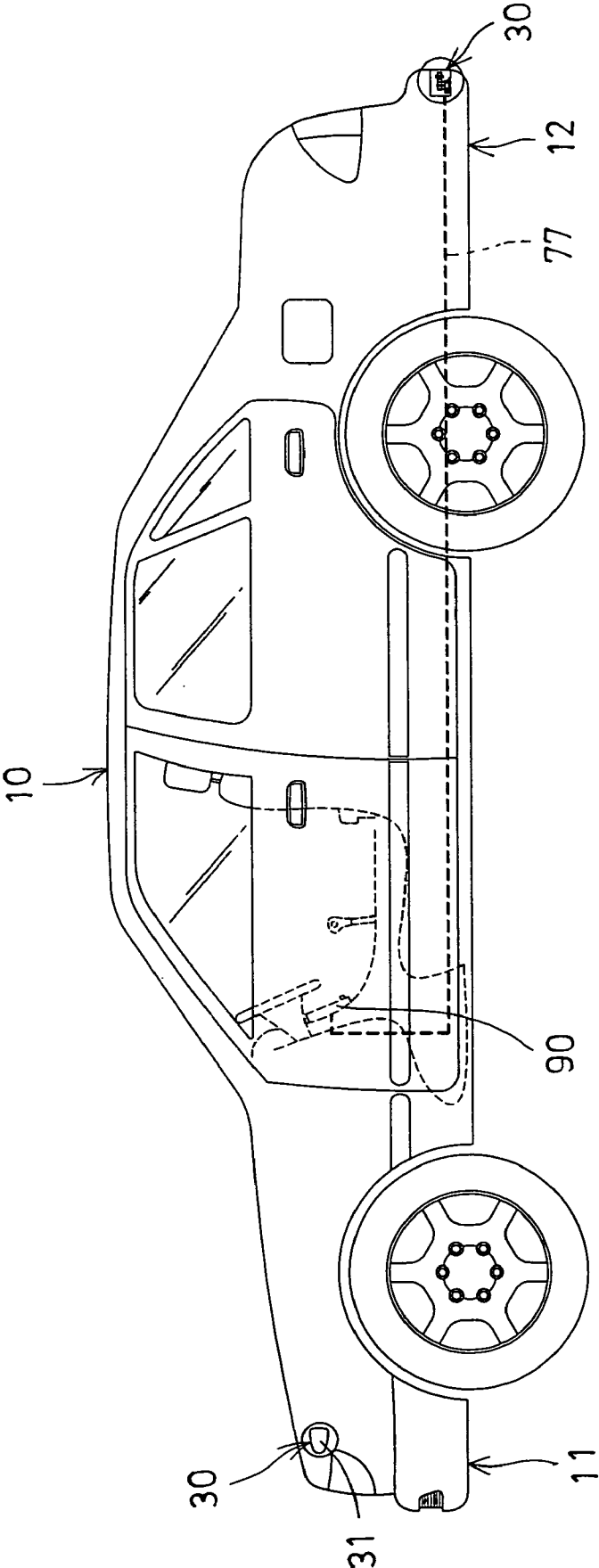

FIG. 2

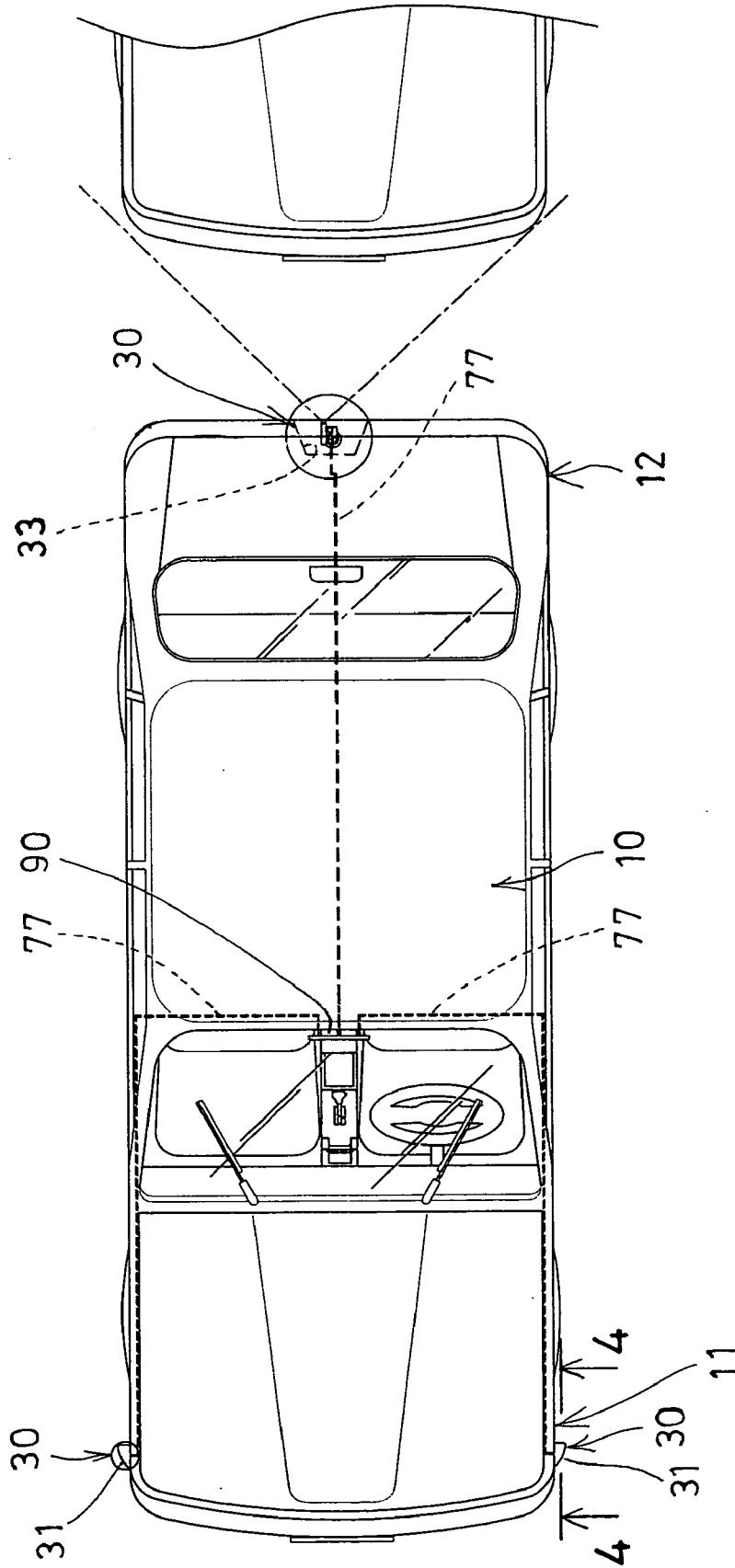

FIG. 3

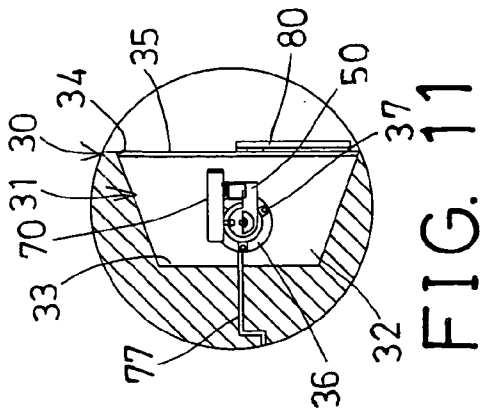

FIG. 11

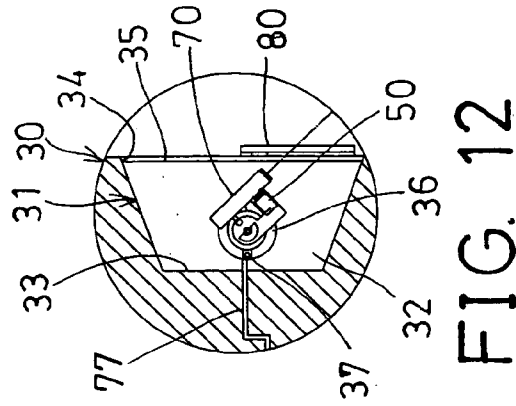

FIG. 12

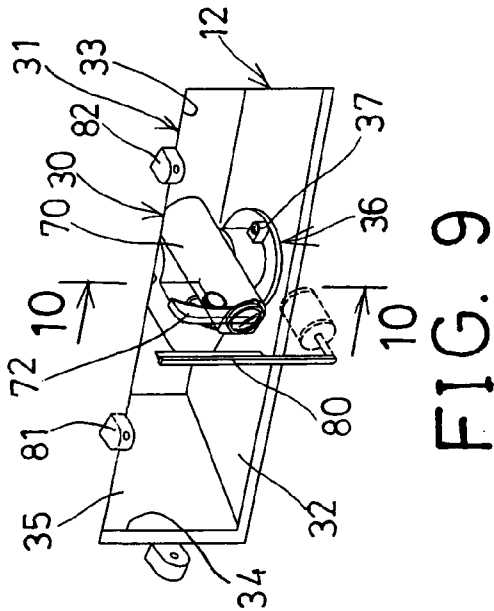

FIG. 9

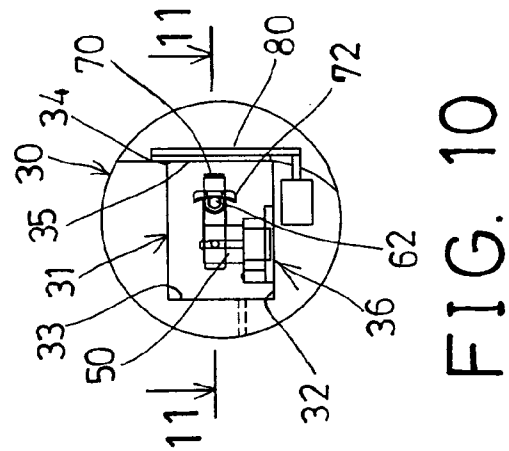

FIG. 10

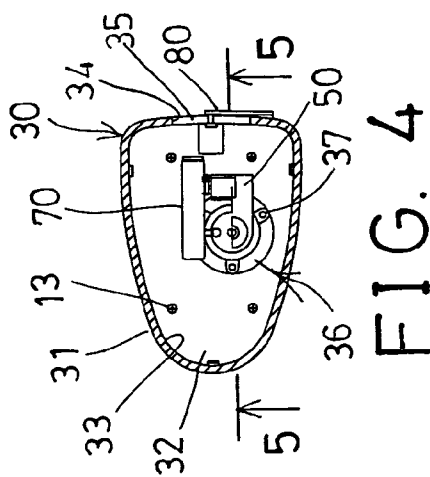

FIG. 4

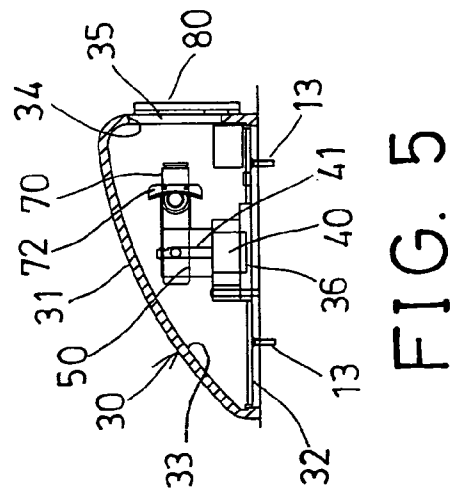

FIG. 5

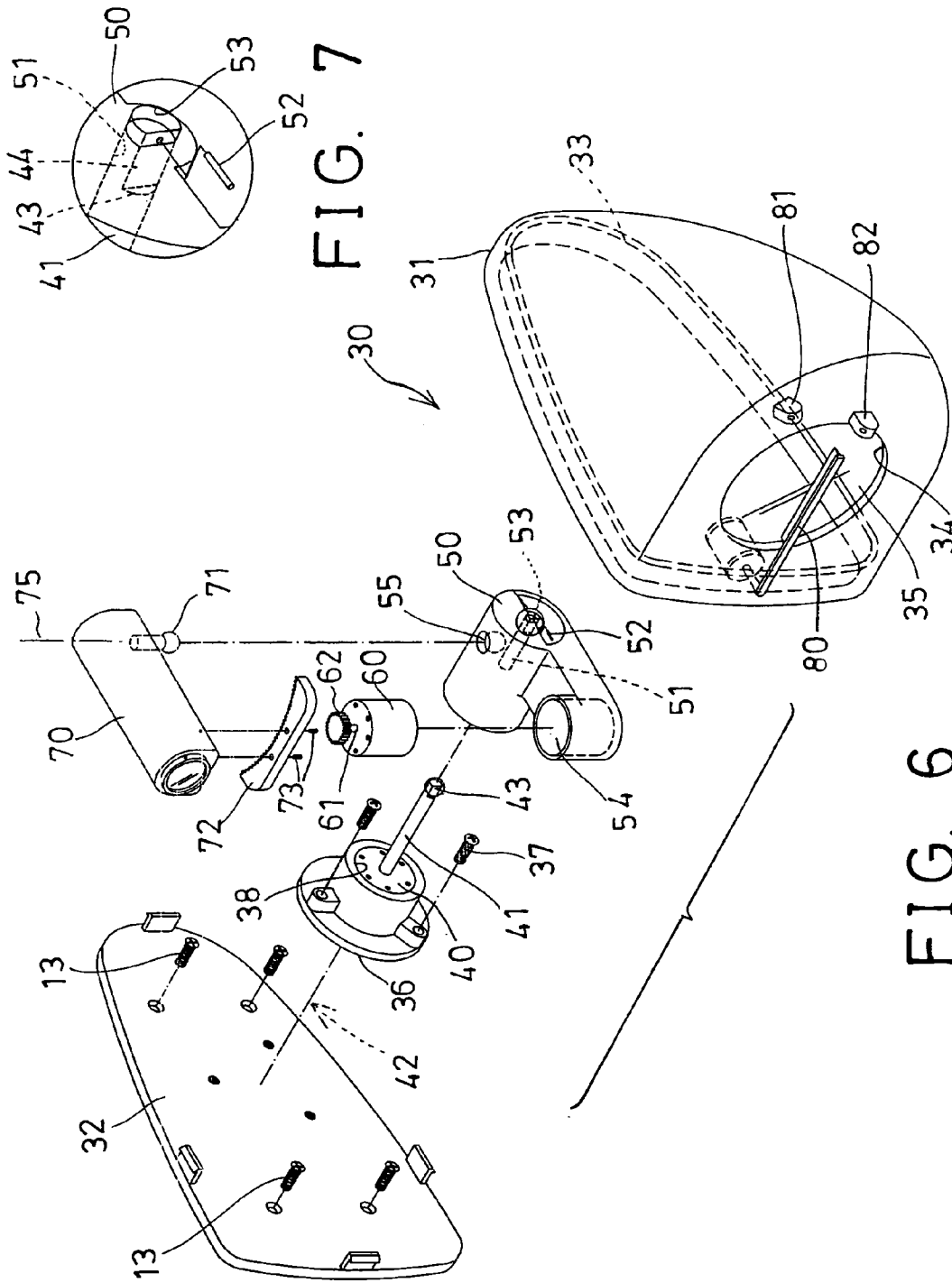

FIG. 7

FIG. 6

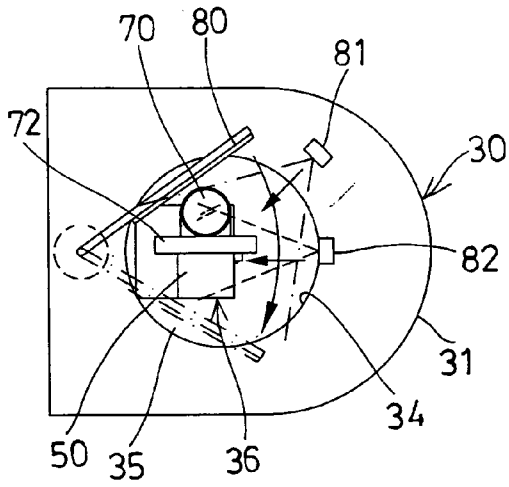

FIG. 17

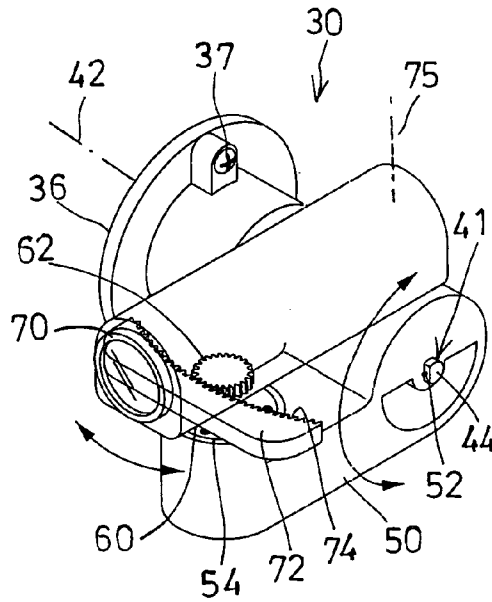

FIG. 8

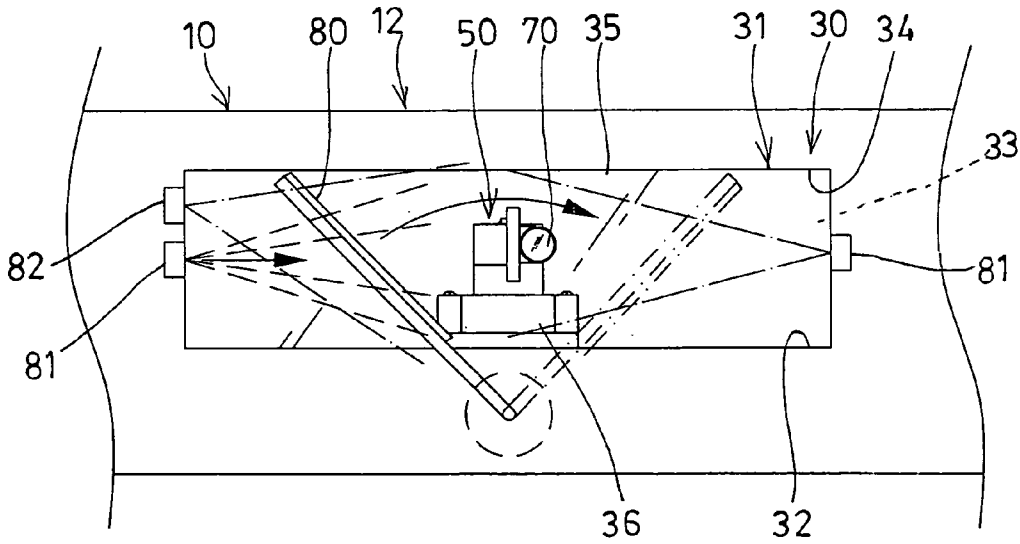

FIG. 18

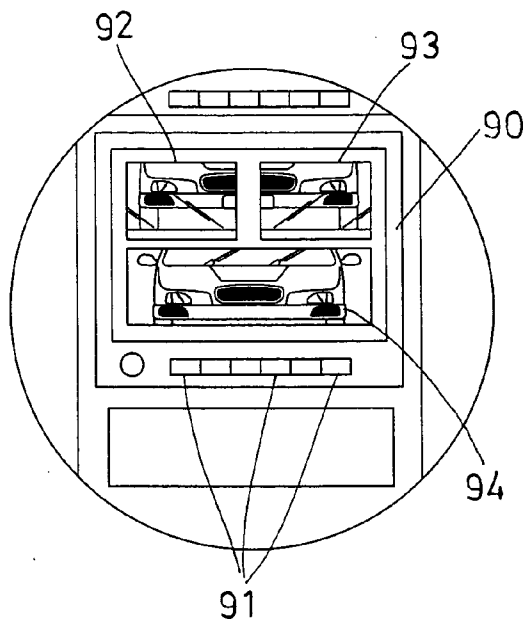

FIG. 13

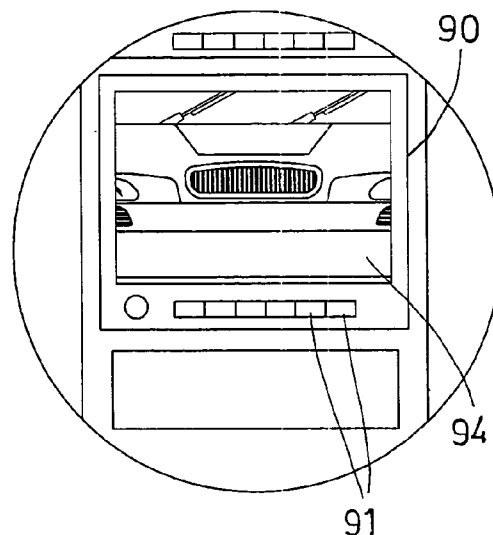

FIG. 14

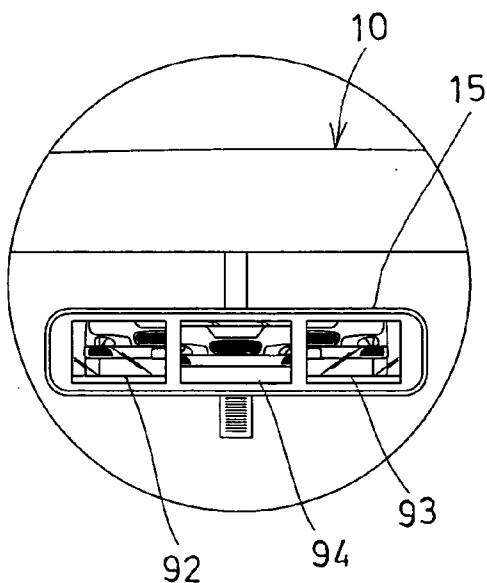

FIG. 15

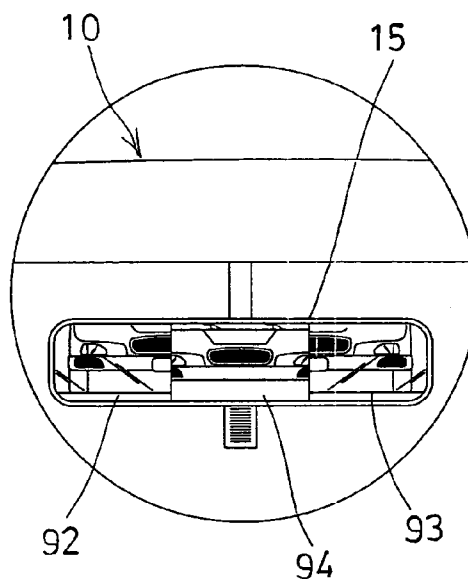

FIG. 16

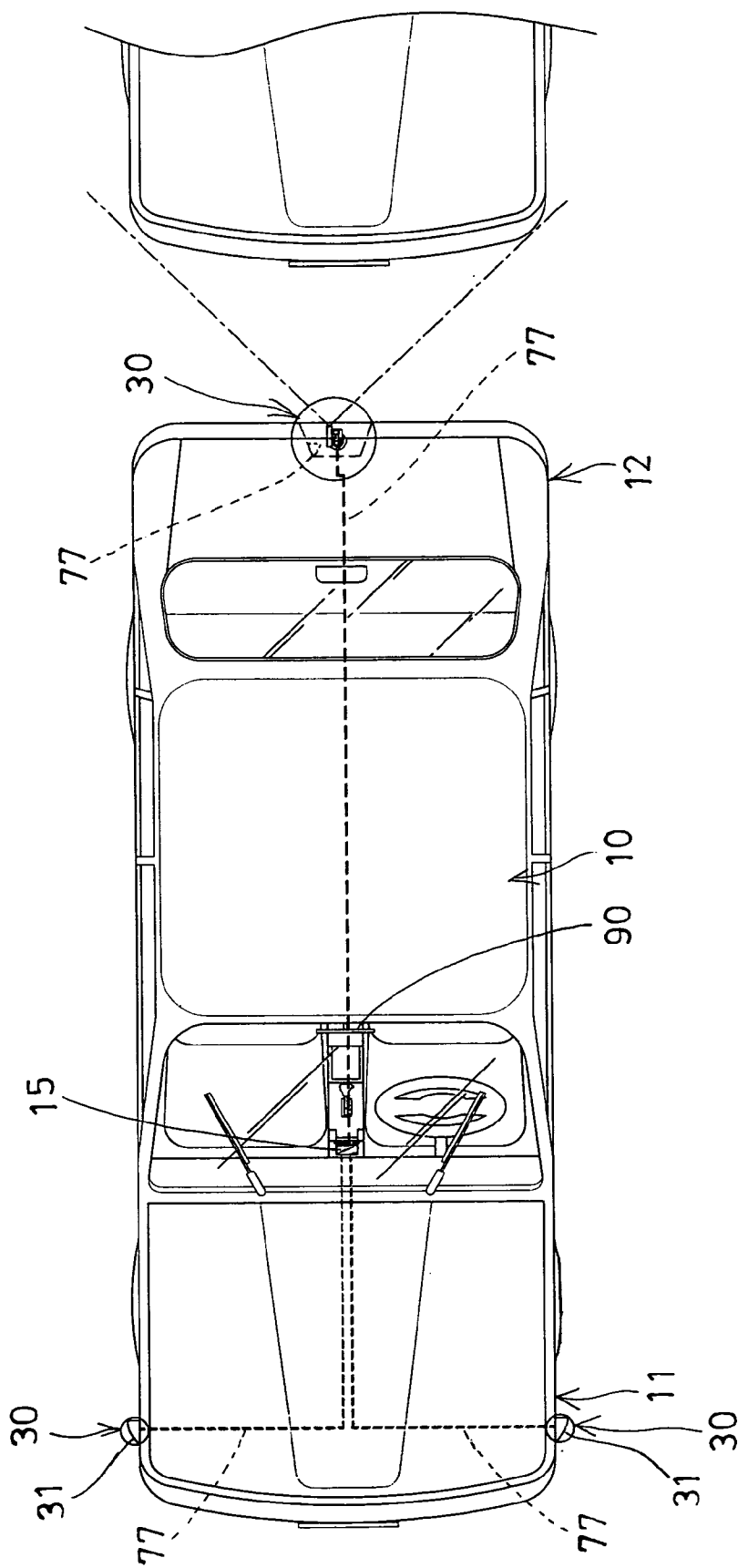

FIG. 19

VEHICLE MONITORING APPARATUS

BACKGROUND OF THE INVENTION

[0001] 1. Field of the Invention

[0002] The present invention relates to a vehicle monitoring apparatus, and more particularly to a vehicle monitoring apparatus having image taking devices or video cameras adjustable to different directions for broadening rearward viewing.

[0003] 2. Description of the Prior Art

[0004] Typical vehicles may comprise a display device provided in a rearview mirror of a vehicle, for showing or displaying various information for the drivers of the vehicles, such as inside temperature in the vehicle, the humidity in the vehicle, the air pressure, the pollution content within the vehicle, the light intensity outside the vehicle, the map of the environment, etc.

[0005] For example, U.S. Pat. No. 5,631,638 to Kaspar et al. discloses a typical information system in a motor vehicle, including one or more electric circuits connected to a vehicle computer of the motor vehicle and one or more sensors, and a display device for displaying information for drivers. However, the typical information system may not be used to show or to view or to see the objects or views behind the vehicles.

[0006] The other typical vehicle monitoring apparatuses have been developed and comprise three or more image taking devices or video cameras attached to two front side portions and a rear portion of vehicles, for taking images or views behind the vehicles, and for allowing the drivers to clearly see the objects or views behind the vehicles.

[0007] For example, U.S. Pat. No. 5,574,443 to Hsieh discloses one of the typical vehicle monitoring apparatuses comprising a display device coupled to three or more video cameras, for taking images or views behind the two side portions and the rear portion of the vehicles, and for allowing the drivers to clearly see the objects or views behind the vehicles via the display device.

[0008] However, the video cameras are solidly fixed to the vehicles, and may not be adjusted relative to the vehicles to different angular directions, such the rearward viewing of the vehicles is limited and may not be directed or adjusted to different viewing directions.

[0009] The present invention has arisen to mitigate and/or obviate the afore-described disadvantages of the conventional vehicle monitoring apparatuses.

SUMMARY OF THE INVENTION

[0010] The primary objective of the present invention is to provide a vehicle monitoring apparatus including one or more image taking devices or video cameras adjustable to different directions for broadening rearward viewing, and for allowing users to reliably and safely view toward various directions behind the vehicles.

[0011] In accordance with one aspect of the invention, there is provided a vehicle monitoring apparatus for a vehicle, comprising an image taking device including a housing, a first motor disposed in the housing and including a spindle extended therefrom, a follower attached to the

spindle of the first motor, and arranged to be rotated and driven by the first motor, the follower including a compartment formed therein, a video camera rotatably attached to the follower, and rotated in concert with the follower, and a second motor disposed in the compartment of the follower and coupled to the video camera, to rotate and adjust the video camera relative to the follower to different angular directions.

[0012] The housing includes a base panel for attaching to the vehicle, and a casing secured to the base panel and having a space formed therein for receiving the first motor therein.

[0013] The follower includes an orifice formed therein for receiving the spindle of the first motor. The follower includes a non-circular portion formed in the orifice thereof, and the spindle of the first motor includes a non-circular end portion received in the non-circular portion of the follower, to prevent the follower from being rotated relative to the spindle of the first motor.

[0014] The follower includes a socket formed therein, the video camera includes a ball attached thereto, and rotatably received in the socket of the follower, to allow the video camera to be rotated and adjusted relative to the follower.

[0015] The video camera includes a rack attached thereto and having a number of teeth provided thereon, the second motor includes a pinion attached thereto and engaged with the teeth of the rack, to rotate and adjust the rack and thus the video camera relative to the follower.

[0016] The housing includes an opening formed therein, and a cap engaged in the opening of the housing, to enclose the opening of the housing, and to prevent dirt or particles from entering into the housing. The image taking device includes a wiper attached to the housing, for wiping and cleaning the cap.

[0017] The image taking device includes at least one water supplying nozzle attached to the housing, for supplying water to clean the cap. The image taking device may further include at least one air supplying nozzle attached to the housing, for supplying air to clean the cap.

[0018] The image taking device includes a control device coupled to the video camera, to control and operate the video camera. The control device includes at least one display device coupled to the video camera, to display images taken by the video camera.

[0019] Further objectives and advantages of the present invention will become apparent from a careful reading of the detailed description provided hereinbelow, with appropriate reference to the accompanying drawings.

BRIEF DESCRIPTION OF THE DRAWINGS

[0020] **FIG. 1** is a rear perspective view of a vehicle in accordance with the present invention including a monitoring apparatus having one or more image taking devices or video cameras adjustable to different directions;

[0021] **FIG. 2** is a side elevational view of the vehicle;

[0022] **FIG. 3** is a top elevational view of the vehicle;

[0023] **FIG. 4** is a partial cross sectional view taken along lines 4-4 of **FIG. 3**;

[0024] FIG. 5 is a partial cross sectional view taken along lines 5-5 of FIG. 4;

[0025] FIG. 6 is a partial exploded view illustrating one of the image taking devices of the vehicle monitoring apparatus in accordance with the present invention;

[0026] FIG. 7 is an enlarged partial perspective view illustrating a portion of the image taking device;

[0027] FIG. 8 is a partial perspective view of the image taking device of the vehicle monitoring apparatus;

[0028] FIG. 9 is an enlarged partial rear perspective view illustrating a rear portion of the vehicle;

[0029] FIG. 10 is an enlarged partial side schematic view illustrating the rear portion of the vehicle;

[0030] FIG. 11 is an enlarged partial cross sectional view taken along lines 11-11 of FIG. 10;

[0031] FIG. 12 is an enlarged partial cross sectional view similar to FIG. 11, illustrating the operation of the image taking device of the vehicle monitoring apparatus;

[0032] FIG. 13 is a partial plan view illustrating the control panel or device of the vehicle monitoring apparatus;

[0033] FIG. 14 is a partial plan view similar to FIG. 13, illustrating the other arrangement of the control panel or device of the vehicle monitoring apparatus;

[0034] FIG. 15 is a partial plan view illustrating the display device of the vehicle monitoring apparatus;

[0035] FIG. 16 is a partial plan view similar to FIG. 15, illustrating the other arrangement of the display device of the vehicle monitoring apparatus;

[0036] FIG. 17 is an enlarged partial plan view illustrating one of the front image taking devices of the vehicle monitoring apparatus;

[0037] FIG. 18 is an enlarged partial plan view illustrating the rear image taking device of the vehicle monitoring apparatus; and

[0038] FIG. 19 is a top elevational view similar to FIG. 3, illustrating the further arrangement of the display device and the control device of the vehicle monitoring apparatus.

DETAILED DESCRIPTION OF THE PREFERRED EMBODIMENT

[0039] Referring to the drawings, and initially to FIGS. 1-3, a vehicle monitoring apparatus in accordance with the present invention comprises one or more, such as two front image taking devices 30 attached to a front portion 11 of a vehicle, and one or more further rear image taking devices 30 attached to a rear portion 12 of the vehicle 10, for taking pictures or for viewing the side portions and the rear portion of the vehicle 10.

[0040] Each of the front image taking devices 30 includes a housing 31 secured to the side portions of the front portion 11 of the vehicle 10 with such as fasteners 13 (FIGS. 4-6). For example, each of the housings 31 of the front image taking devices 30 includes a base panel 32 secured to the vehicle 10 with the fasteners 13. The rear image taking device 30 also includes a housing 31 formed in the rear portion 12 of the vehicle 10 (FIGS. 1 and 9-12), and having a base panel 32 formed or provided therein.

[0041] As shown in FIGS. 4-8, each of the image taking devices 30 includes a chamber 33 formed in the housing 31, and includes an opening 34 formed therein and communicating with the chamber 33 thereof, and includes a glass or transparent or semi-transparent cap 35 engaged in the opening 34 thereof, for enclosing the opening 34 and the chamber 33 thereof, and for preventing dirt or particles or other objects from entering into the housings 31, and for protecting the image taking devices 30.

[0042] Each of the image taking devices 30 further includes a casing 36 disposed in the chamber 33 thereof, and secured to the base panel 32 with such as fasteners 37, and having a space 38 formed therein for receiving a motor 40 therein. The motor 40 includes a spindle 41 extended therefrom and having a longitudinal axis 42, and having a cut off portion 43 formed in the free end portion 44 thereof (FIG. 7), to form or define one or more flat surfaces therein, or to form a non-circular free end portion 44 for the spindle 41.

[0043] A follower 50 includes an orifice 51 formed therein (FIGS. 6, 7), for receiving the spindle 41 of the motor 40, which may be secured to the follower 50 with such as lock pins 52, fasteners, latches, or the like. It is preferable that the follower 50 also includes a corresponding non-circular portion 53 formed in the orifice 51 thereof (FIG. 6), for receiving the corresponding non-circular free end portion 44 of the spindle 41.

[0044] For example, as shown in FIG. 8, the non-circular free end portion 44 of the spindle 41 may be engaged out through the corresponding non-circular portion 53 of the orifice 51 of the follower 50, and then locked or secured to the follower 50 with the lock pins 52, to prevent the follower 50 from being rotated relative to the spindle 41 of the motor 40, and thus to allow the follower 50 to be rotated or driven by the motor 40.

[0045] The follower 50 further includes a compartment 54 formed therein (FIGS. 6, 8), for receiving another motor 60, which includes a spindle 61 offset or spaced away from the spindle 41 of the motor 40, and inclined or perpendicular to the spindle 41 of the motor 40. The motor 60 further includes a pinion 62 secured to the spindle 61 thereof and rotated in concert with the spindle 61 thereof. The follower 50 further includes a socket 55 formed therein.

[0046] A video camera 70, such as a charge couple device (CCD) 70 includes a ball 71 attached to a rear portion thereof, and rotatably received in the socket 55 of the follower 50, to allow the video camera 70 to be rotated or adjusted relative to the follower 50 about a rotating axis 75 that is perpendicular to the longitudinal axis 42 of the spindle 41 of the motor 40, and includes a rack 72 secured to the front portion thereof with such as fasteners 73, and having a number of teeth 74 provided therein, for engaging with the pinion 62, and thus for allowing the video camera 70 to be rotated or adjusted relative to the follower 50 by the motor 60, toward different angular directions.

[0047] In operation, as shown in FIG. 8, the follower 50 and the video camera 70 may be rotated or driven or adjusted by the motor 40 around the longitudinal axis 42 of the spindle 41 of the motor 40. In addition, the video camera 70 may also be the rotated or driven or adjusted by the motor 60 around the rotating axis 75 of the video camera 70, to allow the video camera 70 to be rotated or adjusted toward different angular directions relative to the follower 50 and the casing 36 by the motors 40, 60, and thus to allow the

video camera 70 to clearly take pictures or to suitably view the side portions and the rear portion of the vehicle 10.

[0048] As shown in FIGS. 4-6, 9-12, and 17-18, each of the front and rear image taking devices 30 includes a wiper 80 attached to the front portion thereof, for wiping the cap 35, and for allowing the video camera 70 to more clearly take pictures or to suitably view the side portions and the rear portion of the vehicle 10. One or more water supplying nozzles 81 and one or more air supplying nozzles 82 may also be attached to the front portion of the image taking devices 30, for supplying water and/or air to clean the cap 35.

[0049] As shown in FIGS. 1-3 and 13-14, the vehicle monitoring apparatus further includes a control device 90 disposed such as beside the driver cabinet, and coupled to the video cameras 70 and/or the motors 40, 60 of the image taking devices 30 with such as electric wires or cables 77, for controlling or operating the video cameras 70 and/or the motors 40, 60 of the image taking devices 30. The control device 90 may further includes one or more screens or display devices 92, 93, 94 provided thereon, and coupled to the video cameras 70 respectively, for displaying the images or pictures taken by the video cameras 70 respectively, and thus for allowing the users to easily see or view the side portions and the rear portion of the vehicle 10.

[0050] As shown in FIGS. 15-16 and 19, the control device 90 of the vehicle monitoring apparatus may further include one or more screens or display devices 92, 93, 94 formed or provided in the rear view mirror 15 of the vehicle 10, and also coupled to the video cameras 70 respectively, for displaying the images or pictures taken by the video cameras 70 respectively, and thus for allowing the users to easily see or view the side portions and the rear portion of the vehicle 10.

[0051] The video cameras 70 of the image taking devices 30 may thus be rotated or adjusted toward different angular directions relative to the follower 50 and the casing 36 by the motors 40, 60, to allow the video camera 70 to clearly take pictures or to suitably view the side portions and the rear portion of the vehicle 10.

[0052] Accordingly, the vehicle monitoring apparatus in accordance with the present invention includes one or more image taking devices or video cameras adjustable to different directions for broadening rearward viewing, and for allowing users to reliably and safely view toward various directions behind the vehicles.

[0053] Although this invention has been described with a certain degree of particularity, it is to be understood that the present disclosure has been made by way of example only and that numerous changes in the detailed construction and the combination and arrangement of parts may be resorted to without departing from the spirit and scope of the invention as hereinafter claimed.

I claim:

1. A vehicle monitoring apparatus for a vehicle, comprising:

- an image taking device including a housing,
- a first motor disposed in said housing and including a spindle extended therefrom,
- a follower attached to said spindle of said first motor, and arranged to be rotated and driven by said first motor, said follower including a compartment formed therein,

a video camera rotatably attached to said follower, and rotated in concert with said follower, and

a second motor disposed in said compartment of said follower and coupled to said video camera, to rotate and adjust said video camera relative to said follower to different angular directions.

2. The vehicle monitoring apparatus as claimed in claim 1, wherein said housing includes a base panel for attaching to the vehicle, and a casing secured to said base panel and having a space formed therein for receiving said first motor therein.

3. The vehicle monitoring apparatus as claimed in claim 1, wherein said follower includes an orifice formed therein for receiving said spindle of said first motor.

4. The vehicle monitoring apparatus as claimed in claim 3, wherein said follower includes a non-circular portion formed in said orifice thereof, and said spindle of said first motor includes a non-circular end portion received in said non-circular portion of said follower, to prevent said follower from being rotated relative to said spindle of said first motor.

5. The vehicle monitoring apparatus as claimed in claim 1, wherein said follower includes a socket formed therein, said video camera includes a ball attached thereto, and rotatably received in said socket of said follower, to allow said video camera to be rotated and adjusted relative to said follower.

6. The vehicle monitoring apparatus as claimed in claim 1, wherein said video camera includes a rack attached thereto and having a plurality of teeth provided thereon, said second motor includes a pinion attached thereto and engaged with said teeth of said rack, to rotate and adjust said rack and thus said video camera relative to said follower.

7. The vehicle monitoring apparatus as claimed in claim 1, wherein said housing includes an opening formed therein, and a cap engaged in said opening of said housing, to enclose said opening of said housing, and to prevent dirt or particles from entering into said housing.

8. The vehicle monitoring apparatus as claimed in claim 7, wherein said image taking device includes a wiper attached to said housing, for wiping and cleaning said cap.

9. The vehicle monitoring apparatus as claimed in claim 7, wherein said image taking device includes at least one water supplying nozzle attached to said housing, for supplying water to clean said cap.

10. The vehicle monitoring apparatus as claimed in claim 7, wherein said image taking device includes at least one air supplying nozzle attached to said housing, for supplying air to clean said cap.

11. The vehicle monitoring apparatus as claimed in claim 1, wherein said image taking device includes a control device coupled to said video camera, to control and operate said video camera.

12. The vehicle monitoring apparatus as claimed in claim 11, wherein said control device includes at least one display device coupled to said video camera, to display images taken by said video camera.