

(19) World Intellectual Property Organization  
International Bureau



(43) International Publication Date  
19 November 2009 (19.11.2009)

PCT

(10) International Publication Number  
**WO 2009/138403 A1**

(51) International Patent Classification:

*C01D 7/00* (2006.01)      *C01D 7/10* (2006.01)  
*C01D 7/24* (2006.01)      *C01D 7/12* (2006.01)

(21) International Application Number:

PCT/EP2009/055722

(22) International Filing Date:

12 May 2009 (12.05.2009)

(25) Filing Language:

English

(26) Publication Language:

English

(30) Priority Data:

08156095.5      13 May 2008 (13.05.2008)      EP  
12/126,651      23 May 2008 (23.05.2008)      US

(71) Applicant (for all designated States except US):  
**SOLVAY (Société Anonyme)** [BE/BE]; Rue du Prince Albert, 33, B-1050 Brussels (BE).

(72) Inventors; and

(75) Inventors/Applicants (for US only): **DAVOINE, Perrine** [BE/BE]; Avenue de la Sarriette 59, B-1020 Brussels (BE). **COUSTRY, Francis M.** [BE/BE]; Kasteellaan, 9, B-1652 Alsemberg (BE). **DETOURNAY, Jean-Paul** [BE/BE]; Bd Brand Whitlock 159, bte 5, B-1200 Brussels (BE). **ALLEN, Kurt** [US/BE]; Rue Henrotte 14, B-1150 Brussels (BE).

(74) Agents: **GILLIARD, Pierre** et al.; SOLVAY SA, Intellectual Property Department, Rue de Ransbeek, 310, B-1120 Bruxelles (BE).

(81) Designated States (unless otherwise indicated, for every

kind of national protection available): AE, AG, AL, AM, AO, AT, AU, AZ, BA, BB, BG, BH, BR, BW, BY, BZ, CA, CH, CN, CO, CR, CU, CZ, DE, DK, DM, DO, DZ, EC, EE, EG, ES, FI, GB, GD, GE, GH, GM, GT, HN, HR, HU, ID, IL, IN, IS, JP, KE, KG, KM, KN, KP, KR, KZ, LA, LC, LK, LR, LS, LT, LU, LY, MA, MD, ME, MG, MK, MN, MW, MX, MY, MZ, NA, NG, NI, NO, NZ, OM, PG, PH, PL, PT, RO, RS, RU, SC, SD, SE, SG, SK, SL, SM, ST, SV, SY, TJ, TM, TN, TR, TT, TZ, UA, UG, US, UZ, VC, VN, ZA, ZM, ZW.

(84) Designated States (unless otherwise indicated, for every

kind of regional protection available): ARIPO (BW, GH, GM, KE, LS, MW, MZ, NA, SD, SL, SZ, TZ, UG, ZM, ZW), Eurasian (AM, AZ, BY, KG, KZ, MD, RU, TJ, TM), European (AT, BE, BG, CH, CY, CZ, DE, DK, EE, ES, FI, FR, GB, GR, HR, HU, IE, IS, IT, LT, LU, LV, MC, MK, MT, NL, NO, PL, PT, RO, SE, SI, SK, TR), OAPI (BF, BJ, CF, CG, CI, CM, GA, GN, GQ, GW, ML, MR, NE, SN, TD, TG).

Published:

- with international search report (Art. 21(3))
- before the expiration of the time limit for amending the claims and to be republished in the event of receipt of amendments (Rule 48.2(h))

(54) Title: PROCESS FOR THE JOINT PRODUCTION OF SODIUM CARBONATE AND SODIUM BICARBONATE

(57) Abstract: Process for the joint production of sodium carbonate and sodium bicarbonate crystals, according to which: - Solid powder derived from sodium sesquicarbonate, having a mean particle diameter comprised between 0,1 and 10mm is dissolved in water; - The resulting water solution is introduced into a crystallizer, wherein a first water suspension comprising sodium carbonate crystals is produced; - The first water suspension is subjected to a separation, in order to produce crystals comprising sodium carbonate on the one hand, which are valorized, and a mother liquor on the other hand; - Part of the mother liquor is taken out of the crystallizer and put into contact in, a gas liquid contactor, with a gas comprising carbon dioxide, in order to produce a second water suspension comprising sodium bicarbonate crystals, which are separated and valorized.



WO 2009/138403 A1

Process for the joint production of sodium carbonate and sodium bicarbonate

This invention relates to a method for the joint production of sodium carbonate and sodium bicarbonate out of trona ore.

Trona ore is a mineral that contains about 90-95 % sodium sesquicarbonate (Na<sub>2</sub>CO<sub>3</sub>.NaHCO<sub>3</sub>.2H<sub>2</sub>O). A vast deposit of mineral trona is found in southwestern Wyoming near Green River. This deposit includes beds of trona and mixed trona and halite (rock salt or NaCl) which covers approximately 2,600 km<sup>2</sup>. The major trona beds range in size from less than 428 km<sup>2</sup> to at least 1,870 km<sup>2</sup>. By conservative estimates, these major trona beds contain about 75 billion metric tons of ore. The different beds overlap each other and are separated by layers of shale. The quality of the trona varies depending on its particular location in the stratum.

A typical analysis of the trona ore mined in Green River is as follows :

TABLE 1

Constituent	Weight Percent
Na <sub>2</sub> CO <sub>3</sub>	43.6
NaHCO <sub>3</sub>	34.5
H <sub>2</sub> O (crystalline and free moisture)	15.4
NaCl	0.01
Na <sub>2</sub> SO <sub>4</sub>	0.01
Fe <sub>2</sub> O <sub>3</sub>	0.14
Insolubles	6.3

The sodium sesquicarbonate found in trona ore is a complex salt that is soluble in water and dissolves to yield approximately 5 parts by weight sodium carbonate (Na<sub>2</sub>CO<sub>3</sub>) and 4 parts sodium bicarbonate (NaHCO<sub>3</sub>), as shown in the above analysis. The trona ore is processed to remove the insoluble material, the organic matter and other impurities to recover the valuable alkali contained in the trona.

The most valuable alkali produced from trona is sodium carbonate. Sodium carbonate is one of the largest volume alkali commodities made in the United States. In 1992, trona-based sodium carbonate from Wyoming comprised about 90 % of the total U.S. soda ash production. Sodium carbonate finds major

use in the glass-making industry and for the production of baking soda, detergents and paper products.

A common method to produce sodium carbonate from trona ore is known as the "monohydrate process". In that process, crushed trona ore is calcined (i.e., heated) into crude sodium carbonate which is then dissolved in water. The resulting water solution is purified and fed to a crystallizer where pure sodium carbonate monohydrate crystals are crystallized. The monohydrate crystals are separated from the mother liquor and then dried into anhydrous sodium carbonate. However, the soluble impurities contained in the trona ore, tend to accumulate into the crystallizer. To avoid build up of impurities, the mother liquor must be purged. The purge liquor, which represents important quantities for industrial monohydrate plants, is commonly sent to evaporative ponds. The significant quantity of alkali which is contained in the purge liquor is consequently lost. Moreover, the stocking of large quantities of purge liquors in evaporative ponds raise environmental problems, because of the scarce availability of new areas for stocking.

On the other side, sodium bicarbonate is a product with a wide range of interesting properties and a very wide range of applications from high tech ingredients for the pharma industry to the human food and animal feed, and to the use in flue gas treatment. In flue gas treatment sodium bicarbonate is most likely among the most efficient chemicals for the removal of a wide range of pollutants (most notably the acidic one), and its use is limited only by the competition of less efficient but much cheaper chemicals such as lime or even limestone.

The production of sodium bicarbonate is currently almost entirely made by the carbonation of sodium carbonate. In Europe, the carbonation is usually performed in situ in the soda ash plants from CO<sub>2</sub> coproduced during the production of soda ash (mainly the CO<sub>2</sub> generation in the lime kilns). In USA, the carbonation is usually made in separate plants which purchase independently the soda ash and the CO<sub>2</sub> and combine them.

Because of the nature of this most important process for the bicarbonate production, the price for bicarbonate is above the price of the soda ash. With such economics the uses of bicarbonate will always be limited by the competition of cheaper substitutes, most notably in the flue gas treatment.

US2003/0017099 discloses a process for the joint production of sodium carbonate and bicarbonate, according to which solid trona is dissolved in water

and the resulting water solution is fed into a monohydrate crystallizer in order to produce sodium carbonate. The purge liquor is introduced into a decahydrate crystallizer and the decahydrate crystals converted into sodium bicarbonate. It has been observed that this process is not efficient when the purge liquor, depending on the trona source, contains high levels of impurities. In particular, the sodium chloride content of the trona ore can vary depending on the precise trona vein which is exploited. High levels of sodium chloride in the purge liquor prevents smooth crystallisation of decahydrate.

The invention aims on one side at reducing the amount of alkali lost in the evaporative ponds and on the other side at producing bicarbonate from trona in a smooth and inexpensive way, thereby opening new applications for the sodium bicarbonate.

Accordingly, the invention concerns a process for the joint production of sodium carbonate and sodium bicarbonate, wherein :

- A solid powder derived from sodium sesquicarbonate, having a mean particle diameter comprised between 0,1 and 10mm is dissolved in water;
- The resulting water solution is introduced into a crystallizer, wherein a first water suspension comprising sodium carbonate crystals is produced;
- The first water suspension is subjected to a separation, in order to obtain crystals comprising sodium carbonate on the one hand, which are valorized, and a mother liquor on the other hand;
- Part of the mother liquor is taken out of the crystallizer and put into contact with a gas comprising carbon dioxide, in order to produce a second water suspension comprising sodium bicarbonate crystals, which are separated and valorized.

The process according to the invention allows the joint production of sodium carbonate and sodium bicarbonate, out of sodium sesquicarbonate. Sodium sesquicarbonate containing intrinsically both sodium carbonate and bicarbonate, this process valorizes in an optimum way the raw materials which are consumed.

In the process according to the invention, solid powder derived from sodium sesquicarbonate is dissolved in water. The expression “derived from sesquicarbonate” means that the powder can consist essentially of sesquicarbonate, but can also consist of a product which results from a direct transformation of sesquicarbonate. For example, the transformation can be a calcination which transforms the sesquicarbonate essentially in sodium

carbonate. The sesquicarbonate can have different origins. It can be produced artificially out of different sodium sources. However, it is recommended that sesquicarbonate comes from a natural trona ore. In this recommended embodiment purification of the water solution obtained after the dissolution of the solid powder in water will in general be necessary, in order to purify it from the main impurities contained in the ore. The purification generally involves settling and filtration steps, to allow insolubles to separate from the water solution. It also involves generally the use of reagents in order to remove organic matters still contained in the purified water solution. Active carbon is an example of such reagent.

The water in which the solid powder derived from sesquicarbonate is dissolved can be fresh water. However water has to be understood in a wide sense. The water can contain recycled water solutions already containing alkalis, coming from the process according to the invention or from other processes. The water can also comprise mother liquors (crystallization waters) produced downstream of the process according to the invention, when sodium carbonate and bicarbonate are crystallized, for instance. The process is also suited when the water is a mine water. By mine water is understood the water solution which is formed when water is directly injected into the trona ore deposits, whereby, on contact with the water, some ore dissolves in it.

The mean particle diameter of the powder which is dissolved in the water is comprised between 0,1 and 10mm. Powders having a mean diameter below 0,1 mm frequently contain too much impurities, f.i. when the sesquicarbonate is a trona ore, whereas powders having a mean diameter above 10 mm tend to be difficult to handle and dissolve in water. The mean diameter is the  $D_{50}$ , that is the diameter such that half of the particles, in weight, have a diameter lower than the specified value. For non spherical particles, the diameter is the equivalent one, that is six times the value of the volume of the particles divided by its external area.

The powder which derives from sesquicarbonate can consist essentially of sesquicarbonate and the impurities accompanying it, as in the embodiment wherein the source of sesquicarbonate is natural trona ore.

In a recommended embodiment of the invention, the powder derived from sesquicarbonate is calcined sesquicarbonate. In this embodiment, the sesquicarbonate is first calcined, preferably at a temperature comprised between 100 and 400°C, before its dissolution in water. During calcination, the sodium

sesquicarbonate in the trona ore breaks down into sodium carbonate, carbon dioxide and water. Also, calcination releases some of the organics associated with trona or trona shale.

5 The quantity of powder derived from sesquicarbonate which is dissolved into water is regulated in order to obtain a resulting water solution containing enough sodium carbonate and bicarbonate to allow smooth crystallization of both chemicals in the later stages of the process. It is recommended that the resulting water solution contains at least 15%, preferably 20%, most preferably 25% in weight of sodium carbonate.

10 The crystallizer into which the resulting water solution is introduced must be able to crystallize sodium carbonate. The crystallized sodium carbonate can be in different hydration forms : monohydrate, decahydrate,... or can be anhydrous.

15 In a preferred embodiment of the invention, the sodium carbonate crystals produced in the crystallizer are in the monohydrate form. The crystallizer is then part of what is commonly referred to as the "monohydrate process". In the monohydrate process, crushed trona ore is calcined at a temperature between 125°C and 250°C to convert sodium bicarbonate into sodium carbonate and form crude soda ash. The resulting crude sodium carbonate and the remaining  
20 organics are then dissolved in water. After dissolving the calcined trona, any undissolved solids are removed and the solution is treated with activated carbon to remove some of the organics present in the solution. The solution is then filtered. One of the advantages of the monohydrate process is that calcined trona dissolves faster than raw trona. Another advantage is that calcined trona can  
25 produce more concentrated sodium carbonate solutions, whose concentrations can reach about 30 %, while dissolved raw trona results into solutions having only about 16 % sodium carbonate plus 10 % sodium bicarbonate. The filtered solution of sodium carbonate is fed to an evaporative crystallizer where some of the water is evaporated and some of the sodium carbonate forms into sodium  
30 carbonate monohydrate crystals ( $\text{Na}_2\text{CO}_3 \cdot \text{H}_2\text{O}$ ). A slurry containing these monohydrate crystals and a mother liquor is removed from the evaporators and the crystals are separated from the mother liquor. The crystals are then calcined, or dried, to convert it to dense soda ash. The mother liquor is recycled back to the evaporator circuit for further processing into sodium carbonate monohydrate  
35 crystals.

In the process according to the invention, the composition of the mother liquor which is put into contact with carbon dioxide can vary according to the crystallization conditions. In general, it is recommended that the mother liquor contains a sufficient quantity of sodium carbonate.

5 In a recommended embodiment of the process according to the invention, the mother liquor contains at least 175 g/kg, preferably 190g/kg, more preferably 205g/kg, most preferably 220g/kg of sodium carbonate. It is however recommended that the mother liquor does not contain more than 250 g/kg, preferably not more than 240g/kg of sodium carbonate. It is also recommended  
10 that the mother liquor does not contain more than 30 g/kg, preferably 20 g/kg, more preferably 15g/kg, most preferably 10g/kg of sodium bicarbonate. It is additionally recommended that the mother liquor contains from 3 to 6, preferably from 4 to 5 equivalent/kg total alkali content. This means that one kg of mother solution contains advantageously from 3 to 6, preferably from 4 to 5 moles on  
15 ion  $\text{Na}^+$ , whether coming from sodium carbonate or sodium bicarbonate.

The process according to the invention allows to directly produce fairly pure sodium bicarbonate crystals out of quite impure mother liquors. The mother liquor is even advantageously a purge stream from the crystallizer, used to maintain the concentration of impurities in the crystallizer below a threshold  
20 value.

In an advantageous embodiment of the invention, the mother liquor contains at least 10 g/kg, preferably 20 g/kg, most preferably 30 g/kg of NaCl.

In another advantageous embodiment of the invention, the mother liquor contains at least 1g/kg, preferably 4 g/kg, most preferably 8 g/kg of  $\text{Na}_2\text{SO}_4$ .

25 In still another advantageous embodiment of the invention, the mother liquor contains at least 0,5 g/kg, preferably 0,6 g/kg of Si (counted as silica).

It is however recommended in those advantageous embodiments that the mother liquor does not contain more than 60 g/kg, preferably not more than 50g/kg of sodium chloride. It is also recommended that the mother liquor does  
30 not contain more than 20 g/kg, more preferably 15g/kg of sodium sulfate and not more than 1,5, preferably 1g/kg of silica.

In those advantageous embodiments, it has been observed that the produced sodium bicarbonate crystals contain much less impurities than the mother liquor. It is advantageous that the crystals contain less than 0,1 g/kg  
35  $\text{Na}_2\text{SO}_4$ , less than 1 g/kg NaCl and less than 5g/kg silica.

In the process according to the invention, the gas comprising carbon dioxide must react efficiently with the mother liquor in the gas liquid reactor. To that end, it is recommended that the gas comprises at least 20% in weight, advantageously 40%, preferably 60%, more preferably 80% CO<sub>2</sub>. It is particularly efficient to use pure (100%) CO<sub>2</sub>. It is also recommended to use a well stirred gas liquid reactor, comprising a gas injector able to distribute the gas homogeneously into the reactor. The liquid constitutes advantageously the continuous phase inside the reactor, the gas being injected at the bottom and moving upwards. The reactor comprises preferably cooling means, to counteract the exothermicity of the reaction. The CO<sub>2</sub> can have different origins. In one recommended embodiment, the CO<sub>2</sub> comes from a natural gas plant, after having been concentrated for example through an amine process. Preferably, the CO<sub>2</sub> comes from the monohydrate soda ash plant, for instance from the calciners used to calcine the trona.

The temperature inside the gas liquid reactor is preferably between 60 and 80°C, more preferably between 65 and 75°C. The temperature of the mother liquor when it is introduced into the reactor is advantageously a little higher, preferably between 80 and 95 °C.

In order to obtain a water suspension comprising enough sodium bicarbonate crystals, it is preferable to maintain a residence time in the gas liquid reactor greater than 10 minutes, more preferably greater than 20 minutes.

The (second) water suspension produced into the gas liquid reactor is subjected to a separation. The separation of the crystals from the suspension can be carried out by any appropriate mechanical separating means, for example by settling, by centrifugation, by filtration or by a combination of these three separating means. The sodium bicarbonate crystals are finally dried and packed.

The process according to the invention is particularly effective to produce crystals with a median diameter ( $D_{50}$ ) between 75 and 250 $\mu\text{m}$ , preferably between 80 and 150  $\mu\text{m}$ .  $D_{10}$  diameters are preferably between 40 and 100  $\mu\text{m}$ , whereas  $D_{90}$  diameters are preferably between 175 and 500 $\mu\text{m}$ .  $D_x$  is the diameter value such that x percent of the particles have a diameter lower than the value. When the particles have an approximately spherical shape, the diameter is the diameter of the particle. For irregular shapes, the diameter is six times the volume of the particle divided by its outer surface.

The sodium bicarbonate crystals produced by the process according to the invention have a very special structure : they contain impurities at a particular,

however low, level. This level is higher than that of conventional sodium bicarbonate crystals f.i. produced out of commercial sodium carbonate. Those impurities are a kind of memory in the bicarbonate crystals of the composition of the mother liquor. The usefulness of those impurities are not yet fully  
5 experienced, but their concentration corresponds to the level of many additives. Positive impact on storage and flowability of powders of such crystals can be expected. The crystals have also a unique granulometry. Moreover, they are extremely advantageous for many applications, in which cost is a major aspect.

The invention concerns also a reagent powder comprising sodium  
10 bicarbonate crystals obtainable by the process according to the invention. The crystals of such reagent powder comprise preferably from 0,1 to 1 g/kg NaCl, and/or from 0,01 to 0,1 g/kg Na<sub>2</sub>SO<sub>4</sub> and/or from 0,5 to 5g/kg silica.

Such reagent powders are particularly suited for the removal of pollutants from gases.

15 Consequently, the invention concerns also a process for treating a gas containing noxious pollutants, preferably HCl and/or SO<sub>2</sub> according to which a reagent powder according to the invention is injected in the gas, the pollutants react with the reagent and the product of the reaction is separated from the gas. The separation of the products of the reaction can most simply be performed by  
20 filtration, using bag filters or electrostatic filters. In this process, it is recommended that the temperature of the gas is above 100°C, preferably 110°C, more preferably 120°C, most preferably 130°C. At those temperatures, the sodium bicarbonate quickly decomposes into sodium carbonate having a high specific surface and thus high reactivity. The decomposition occurs within  
25 seconds, in the gas treatment duct. The reagent is injected in the dry or semidry state. By semidry state injection is understood injection of fine droplets of a water solution or preferably suspension of the reagent into a hot gas, having a temperature above 100°C. The solution or suspension evaporates immediately after its contact with the hot gas.

30 In the process for the joint production of sodium carbonate and sodium bicarbonate crystals according to the invention, the gas comprising CO<sub>2</sub> is preferably produced by indirect calcination of a composition releasing CO<sub>2</sub> upon calcination, preferably a composition comprising an alkali bicarbonate, more preferably sesquicarbonate or trona. Calcination of trona is advantageously  
35 operated between 140 and 180°C. By indirect calcination is meant calcination wherein the composition to be calcined is not in direct contact with the heat

source utilized to warm the calciner. This is indeed the situation in conventional calciners, wherein the composition is in direct contact with the combustion gases produced by the burning fuel. In this embodiment, it is recommended to use steam heated calciners, wherein the steam is circulated into pipes, and the composition, preferably trona, is heated by contact with the exterior surface of the pipes. The steam is advantageously produced by electricity and steam cogeneration. It has been observed that the gas comprising CO<sub>2</sub> which is produced that way, after suitable drying for instance by a condensing step, has an elevated concentration in CO<sub>2</sub>, typically more than 80% in volume, preferably more than 90%, most preferably more than 95%. The CO<sub>2</sub> has also a great purity. Thanks to those properties, a gas comprising CO<sub>2</sub> produced that way is especially suitable for the production of sodium bicarbonate out of a water solution comprising sodium carbonate.

Consequently, the invention concerns finally also a process for the production of sodium bicarbonate crystals, according to which :

- A composition releasing CO<sub>2</sub> upon calcination is indirectly calcinated in order to produce a gas comprising CO<sub>2</sub>;
- a water solution comprising sodium carbonate is put into contact, in a gas liquid contactor, with the gas comprising CO<sub>2</sub>, in order to produce a water suspension comprising sodium bicarbonate crystals, which are separated.

In this process, the solution comprising sodium carbonate comprises preferably at least 175g/kg of sodium carbonate, and the gas comprising CO<sub>2</sub> comprises at least 90% CO<sub>2</sub>. The sodium carbonate is preferably produced by the monohydrate process described in this specification. Other preferred embodiments of the process for the joint production of sodium carbonate and sodium bicarbonate crystals described above are also advantageously adapted to this process for the production of sodium bicarbonate.

The annexed figure illustrates a particular embodiment of the invention. Crushed sodium carbonate crystals 1, originating from calcined trona ore, and water 2 are introduced in a leaching tank 3. The resulting water solution, containing insolubles in suspension, is filtered and purified in a purification unit 5. The purified water solution 6 is introduced into a monohydrate crystallizer 7, wherein a suspension 8 containing sodium carbonate monohydrate crystals is produced. Those crystals 10 are separated from the suspension in a separator 9. The resulting mother liquor 11 is sent back to the crystallizer 7. A purge stream 12 from the crystallizer 7 is carbonated in a reactor 13, fed by

carbon dioxide 14. A water suspension 15 comprising sodium bicarbonate crystals is extracted from the reactor 13. The crystals 22 are finally separated in a filter 16. The second mother liquor 17 is debicarbonated with vapor 20 and then sent to a storage pond. Carbon dioxide 19 is advantageously recycled.

5           Details and particularities of the invention will appear from the description of the following examples.

#### Example 1

Crushed trona ore originating from Wyoming was used as feed material in a monohydrate process for the production of sodium carbonate. Accordingly, the  
10           crushed trona ore was calcined at a temperature of 170°C. The resulting sodium carbonate was leached in a quantity regulated in order to get a water solution containing 30 % (weight) of sodium carbonate. The resulting water solution was then filtered, purified and introduced into a crystallizer, according to the monohydrate process. A first water suspension comprising sodium carbonate  
15           monohydrate crystals was produced in the crystallizer. The suspension was submitted to a separation, resulting in sodium carbonate monohydrate crystals (which are further processed into dense anhydrous sodium carbonate crystals) on one side and a (first) mother liquor on the other side. Part of the mother liquor was then taken out of the crystallizer, as part of a purge stream. The composition  
20           of the mother liquor is given in table 1. The mother liquor was stored in a tank and heated at 87°C. This mother liquor was introduced from the tank into a lab-scale, atmospheric pressure gas-liquid reactor, at a flow rate of 1,6 kg/h. The reactor was agitated and maintained at 70°C. A carbon dioxide gas stream (100% CO<sub>2</sub>), saturated at about 40°C was introduced into the reactor at a flow  
25           rate of 0,8 m<sup>3</sup>/h and approximately atmospheric pressure. Residence time into the reactor was calculated as approximately 1h. A second water suspension comprising sodium bicarbonate crystals was produced and extracted from the bottom of the reactor. The crystals were separated from the suspension. The resulting second mother liquor had the composition given in table 2. Size and  
30           composition of those crystals are given in table 3.

#### Example 2

In example 2, it was processed as in example 1, except that another specimen of mother liquor was submitted to carbonation, with slightly higher alkali content. The residence time was also increased to 2hours. The results are  
35           given in tables 1 to 3. The residual sodium carbonate content of the second

mother liquor was much higher than in example 1. The sodium bicarbonate crystals comprised also more fine particles (greater span).

#### Example 3

5 In example 3, it was operated as in example 2 (2h residence time) and the same specimen of mother liquor was used than in example 2, but was further slightly diluted with water, in order to bring its alkali content back to the value of example 1. The results are given in tables 1 to 3. The residual sodium carbonate content of the second mother liquor was back to the value of example 1.

#### 10 Example 4

In example 4, it is operated as in example 1, except that the purge stream from the crystallizer is sent into a pilot scale reactor, at a flow rate of 320 kg/h. Carbon dioxide having a concentration of 75% is introduced into the reactor at a flow rate of 18,5 Nm<sup>3</sup>/h, and at a pressure of 2,5 absolute bars. The crystals  
15 separated from the extracted suspension have approximately the same composition as those of example 1. Their diameters have a D<sub>10</sub> of 60µm, a D<sub>50</sub> of 120µm and a D<sub>90</sub> of 200µm.

	Example 1	Example 2	Example 3
NaHCO <sub>3</sub>	9 g/kg	14 g/kg	9 g/kg
Na <sub>2</sub> CO <sub>3</sub>	229 g/kg	239 g/kg	229 g/kg
NaCl	35 g/kg	39 g/kg	36 g/kg
Na <sub>2</sub> SO <sub>4</sub>	9 g/kg	10 g/kg	9 g/kg
Ca	8 mg/kg		
Mg	0,7mg/kg		
Fe	0,1mg/kg		
Al	0,3 mg/kg		
Si	800 mg/kg		
COT	613 mg/kg		
H <sub>2</sub> O	718 g/kg	698 g/kg	717 g/kg

Table 1

- 12 -

	Example 1	Example 2	Example 3
NaHCO <sub>3</sub>	93 g/kg	63 g/kg	96 g/kg
Na <sub>2</sub> CO <sub>3</sub>	46 g/kg	115 g/kg	44 g/kg
NaCl	39 g/kg	45 g/kg	32 g/kg
Na <sub>2</sub> SO <sub>4</sub>	10 g/kg	12 g/kg	7 g/kg
Ca	0,5 mg/kg		
Mg	0,2 mg/kg		
Fe	<0,04 mg/kg		
Al	<0,04 mg/kg		
Si	400 mg/kg		
COT	602 mg/kg		
H <sub>2</sub> O	812 g/kg	765 g/kg	821 g/kg

Table 2

	Example 1	Example 2	Example 3
NaHCO <sub>3</sub>	977 g/kg	989 g/kg	985 g/kg
Na <sub>2</sub> CO <sub>3</sub>	18 g/kg	9 g/kg	10 g/kg
NaCl	0,3 g/kg		
Na <sub>2</sub> SO <sub>4</sub>	80 mg/kg		
Ca	23 mg/kg	43 mg/kg	37 mg/kg
Mg	2,5 mg/kg		
Fe	0,4 mg/kg		
Al	1,0 mg/kg		
Si	2,6 g/kg		
COT	<50 mg/kg		
D <sub>10</sub>	22 μm	21 μm	40 μm
D <sub>50</sub>	89 μm	80 μm	110 μm
D <sub>90</sub>	222 μm	294 μm	220 μm
Span	2,2	3,4	1,6

Table 3

CLAIMS

1. Process for the joint production of sodium carbonate and sodium bicarbonate crystals, according to which :
- 5       ▪ Solid powder derived from sodium sesquicarbonate, having a mean particle diameter comprised between 0,1 and 10mm is dissolved in water;
  - The resulting water solution is introduced into a crystallizer, wherein a first water suspension comprising sodium carbonate crystals is produced;
  - 10       ▪ The first water suspension is subjected to a separation, in order to obtain crystals comprising sodium carbonate on the one hand, which are valorized, and a mother liquor on the other hand;
  - Part of the mother liquor is taken out of the crystallizer and put into contact, in a gas liquid contactor, with a gas comprising carbon dioxide, in order to produce a second water suspension comprising sodium bicarbonate crystals, which are separated and valorized.
- 15       2. Process according to claim 1, wherein the powder derived from sodium sesquicarbonate is calcined sodium sesquicarbonate.
3. Process according to claim 2, wherein the sodium carbonate crystals which are obtained out of the first water suspension are in the monohydrate form.
- 20       4. Process according to claim 3, wherein the mother liquor which is taken out of the crystallizer contains at least 175 g/kg of sodium carbonate.
5. Process according to claim 1, wherein the mother liquor which is taken out of the crystallizer contains at least 1g/kg of Na<sub>2</sub>SO<sub>4</sub>.
6. Process according to claim 1, wherein the sodium bicarbonate crystals contain less than 0,1g/kg Na<sub>2</sub>SO<sub>4</sub>.
- 25       7. Process according to claim 1, wherein the gas comprising carbon dioxide comprises at least 20% CO<sub>2</sub>.

- 14 -

8. Process according to claim 1, wherein the gas comprising CO<sub>2</sub> is produced by indirect calcination of a composition releasing CO<sub>2</sub> upon calcination.

5 9. Reagent powder comprising sodium bicarbonate crystals obtainable by the process according to claims 1 to 8.

10. Reagent powder according to the preceding claim, comprising from 0,1 to 1 g/kg NaCl, and/or from 0,01 to 0,1 g/kg Na<sub>2</sub>SO<sub>4</sub> and/or from 0,5 to 5g/kg silica.

10 11. Process for treating a gas containing noxious pollutants, according to which a reagent powder according to claim 9 is injected in the gas, the pollutants react with the reagent and the product of the reaction is separated from the gas.

12. Process according to claim 11 wherein the pollutants comprise HCl and/or SO<sub>2</sub>.

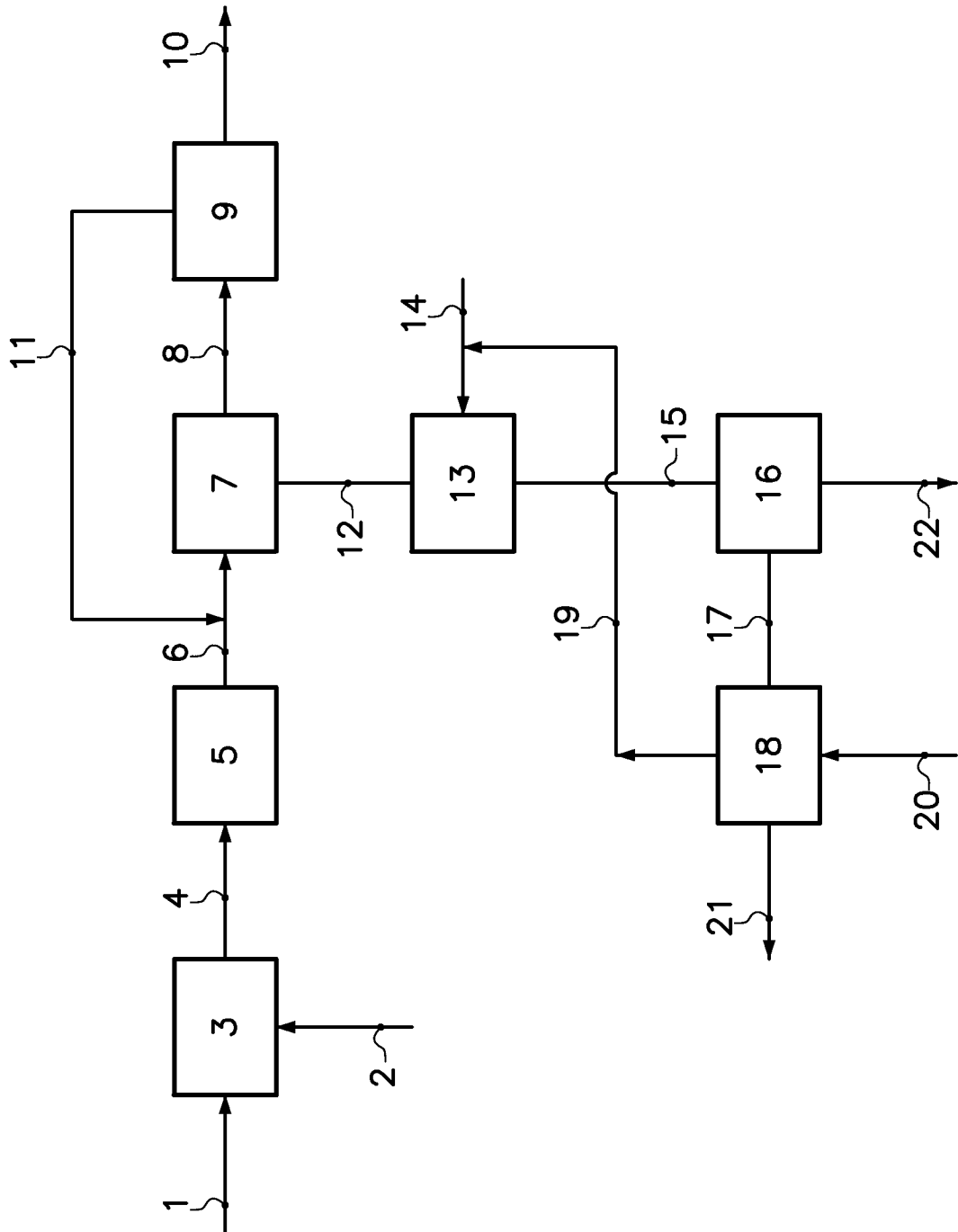

**INTERNATIONAL SEARCH REPORT**

International application No  
PCT/EP2009/055722

**A. CLASSIFICATION OF SUBJECT MATTER**

INV. C01D7/00 C01D7/24 C01D7/10 C01D7/12

According to International Patent Classification (IPC) or to both national classification and IPC

**B. FIELDS SEARCHED**

Minimum documentation searched (classification system followed by classification symbols)  
C01D

Documentation searched other than minimum documentation to the extent that such documents are included in the fields searched

Electronic data base consulted during the international search (name of data base and, where practical, search terms used)

EPO-Internal

**C. DOCUMENTS CONSIDERED TO BE RELEVANT**

Category*	Citation of document, with indication, where appropriate, of the relevant passages	Relevant to claim No.
X	US 2006/182675 A1 (CEYLAN ISMAIL [TR] ET AL) 17 August 2006 (2006-08-17) paragraphs [0024], [0025], [0034] - [0045], [0053], [0055]; figure 1	1-12
X	US 6 171 567 B1 (FAGIOLINI NILO [IT]) 9 January 2001 (2001-01-09) column 4, line 41 - line 55; claim 1	9,11,12
X	US 5 474 581 A (NINANE LEON [FR] ET AL) 12 December 1995 (1995-12-12) column 6, line 40 - line 46	9,11,12
X	US 4 385 039 A (LOWELL PHILIP S ET AL) 24 May 1983 (1983-05-24) claim 1	9,11,12
	----- -/--	

Further documents are listed in the continuation of Box C.

See patent family annex.

\* Special categories of cited documents :

- \*A\* document defining the general state of the art which is not considered to be of particular relevance
- \*E\* earlier document but published on or after the international filing date
- \*L\* document which may throw doubts on priority claim(s) or which is cited to establish the publication date of another citation or other special reason (as specified)
- \*O\* document referring to an oral disclosure, use, exhibition or other means
- \*P\* document published prior to the international filing date but later than the priority date claimed

- \*T\* later document published after the international filing date or priority date and not in conflict with the application but cited to understand the principle or theory underlying the invention
- \*X\* document of particular relevance; the claimed invention cannot be considered novel or cannot be considered to involve an inventive step when the document is taken alone
- \*Y\* document of particular relevance; the claimed invention cannot be considered to involve an inventive step when the document is combined with one or more other such documents, such combination being obvious to a person skilled in the art.
- \*&\* document member of the same patent family

Date of the actual completion of the international search

28 August 2009

Date of mailing of the international search report

04/09/2009

Name and mailing address of the ISA/

European Patent Office, P.B. 5818 Patentlaan 2  
NL - 2280 HV Rijswijk  
Tel. (+31-70) 340-2040,  
Fax: (+31-70) 340-3016

Authorized officer

Engelen, Karen

## INTERNATIONAL SEARCH REPORT

International application No  
PCT/EP2009/055722

C(Continuation). DOCUMENTS CONSIDERED TO BE RELEVANT

Category*	Citation of document, with indication, where appropriate, of the relevant passages	Relevant to claim No.
X	US 2003/017099 A1 (KURTZ ANDREW D [US]) 23 January 2003 (2003-01-23) cited in the application paragraph [0019]; claim 5; example 1 -----	1-10
X	US 4 104 033 A (MAHN FREDERICK ET AL) 1 August 1978 (1978-08-01) column 1, line 11 - line 17 column 2, line 56 - line 62 column 3, line 19 - line 61 claims 1,16 -----	1-10
X	US 5 624 647 A (ZOLOTOCHIN VLADIMIR M [US] ET AL) 29 April 1997 (1997-04-29) column 3, line 44 - column 4, line 1 column 5, line 57 - column 9, line 7; figure 1 -----	1-10
X	US 2003/049192 A1 (BRAMAN VICTOR EUGENE [US] ET AL BRAMAN VICTOR EUGENE [US] ET AL) 13 March 2003 (2003-03-13) claims 1,2,13; figure 1 -----	1-10

# INTERNATIONAL SEARCH REPORT

Information on patent family members

International application No

PCT/EP2009/055722

Patent document cited in search report	Publication date	Patent family member(s)	Publication date
US 2006182675	A1	17-08-2006	CN 1772615 A 17-05-2006
			TR 200403060 A2 21-06-2006
US 6171567	B1	09-01-2001	AT 160518 T 15-12-1997
			AU 686310 B2 05-02-1998
			AU 1533895 A 08-08-1995
			BG 63194 B1 29-06-2001
			BG 100728 A 28-02-1997
			BR 9506527 A 16-09-1997
			CA 2181386 A1 27-07-1995
			CN 1143333 A 19-02-1997
			CZ 9602150 A3 13-11-1996
			DE 69501113 D1 08-01-1998
			DE 69501113 T2 10-06-1998
			DK 740577 T3 10-08-1998
			WO 9519835 A1 27-07-1995
			EP 0740577 A1 06-11-1996
			ES 2112044 T3 16-03-1998
			FI 962924 A 19-07-1996
			GR 3026119 T3 29-05-1998
			HK 1003489 A1 30-10-1998
			HU 77492 A2 28-05-1998
			IT 1269193 B 21-03-1997
			JP 4243347 B2 25-03-2009
			JP 9507654 T 05-08-1997
			JP 2008012535 A 24-01-2008
			NO 963020 A 17-09-1996
			NZ 278870 A 28-01-1999
			PL 315555 A1 12-11-1996
			RO 117510 B1 30-04-2002
RU 2135269 C1 27-08-1999			
SG 59981 A1 22-02-1999			
SK 94396 A3 05-03-1997			
US 5474581	A	12-12-1995	AT 163903 T 15-03-1998
			CZ 9400118 A3 13-07-1994
			DE 69224746 D1 16-04-1998
			DE 69224746 T2 22-10-1998
			DK 595861 T3 21-12-1998
			WO 9302014 A1 04-02-1993
			EP 0595861 A1 11-05-1994
			ES 2115674 T3 01-07-1998
			FR 2679221 A1 22-01-1993
			HU 67592 A2 28-04-1995
US 4385039	A	24-05-1983	NONE
US 2003017099	A1	23-01-2003	US 2004057892 A1 25-03-2004
US 4104033	A	01-08-1978	NONE
US 5624647	A	29-04-1997	NONE
US 2003049192	A1	13-03-2003	NONE