



INTERNATIONAL APPLICATION PUBLISHED UNDER THE PATENT COOPERATION TREATY (PCT)

<p>(51) International Patent Classification ⁷ : H01M 2/08, 2/12, 2/32</p>	<p>A1</p>	<p>(11) International Publication Number: WO 00/11735</p> <p>(43) International Publication Date: 2 March 2000 (02.03.00)</p>									
<p>(21) International Application Number: PCT/US99/18606</p> <p>(22) International Filing Date: 16 August 1999 (16.08.99)</p> <p>(30) Priority Data:</p> <table border="0"> <tr> <td>60/097,445</td> <td>21 August 1998 (21.08.98)</td> <td>US</td> </tr> <tr> <td>60/102,951</td> <td>2 October 1998 (02.10.98)</td> <td>US</td> </tr> <tr> <td>09/293,677</td> <td>16 April 1999 (16.04.99)</td> <td>US</td> </tr> </table> <p>(71) Applicant: EVEREADY BATTERY COMPANY, INC. [US/US]; P.O. Box 450777, 25225 Detroit Road, Westlake, OH 44145 (US).</p> <p>(72) Inventors: TUCHOLSKI, Gary, R.; 6317 Dellrose Drive, Parma Heights, OH 44130 (US). SONDECKER, George, R.; 2202 Berkley Lane, Asheboro, NC 27203 (US).</p> <p>(74) Agent: TOYE, Russell, H., Jr.; Eveready Battery Company, Inc., P.O. Box 450777, 25225 Detroit Road, Westlake, OH 44145 (US).</p>		60/097,445	21 August 1998 (21.08.98)	US	60/102,951	2 October 1998 (02.10.98)	US	09/293,677	16 April 1999 (16.04.99)	US	<p>(81) Designated States: AL, AM, AT, AU, AZ, BA, BB, BG, BR, BY, CA, CH, CN, CU, CZ, DE, DK, EE, ES, FI, GB, GE, GH, GM, HU, ID, IL, IN, IS, JP, KE, KG, KP, KR, KZ, LC, LK, LR, LS, LT, LU, LV, MD, MG, MK, MN, MW, MX, NO, NZ, PL, PT, RO, RU, SD, SE, SG, SI, SK, SL, TJ, TM, TR, TT, UA, UG, UZ, VN, YU, ZW, ARIPO patent (GH, GM, KE, LS, MW, SD, SL, SZ, UG, ZW), Eurasian patent (AM, AZ, BY, KG, KZ, MD, RU, TJ, TM), European patent (AT, BE, CH, CY, DE, DK, ES, FI, FR, GB, GR, IE, IT, LU, MC, NL, PT, SE), OAPI patent (BF, BJ, CF, CG, CI, CM, GA, GN, GW, ML, MR, NE, SN, TD, TG).</p> <p>Published <i>With international search report.</i></p>
60/097,445	21 August 1998 (21.08.98)	US									
60/102,951	2 October 1998 (02.10.98)	US									
09/293,677	16 April 1999 (16.04.99)	US									
<p>(54) Title: ELECTROCHEMICAL CELL HAVING LOW PROFILE SEAL ASSEMBLY</p>											
<p>(57) Abstract</p>											
<p>An electrochemical cell is provided comprising: a can (312) for containing electrochemically active materials, the can (312) including an open end and a closed end; a first outer cover (345) positioned across the open end of the can (312); a collector (340) electrically coupled to the first outer cover (345) and extending internally within the can (312) to electrically contact one of the positive and negative electrodes; and an annular seal (330) having an L-shaped cross section disposed between the can (312) and the first outer cover (345) for electrically insulating the can (312) from the first outer cover (345) and creating a seal between the first outer cover (345) and the can (312). A pressure relief mechanism such as a groove (370) is preferably formed in the closed end of the can (312). Also provided is a collector and seal assembly for such electrochemical cell, and a method of assembling the electrochemical cell. The cell construction allows a large internal volume to be available for containing electrochemically active materials. The collector may have the shape of a nail and the seal may have a J-shaped cross section.</p>											

FOR THE PURPOSES OF INFORMATION ONLY

Codes used to identify States party to the PCT on the front pages of pamphlets publishing international applications under the PCT.

AL	Albania	ES	Spain	LS	Lesotho	SI	Slovenia
AM	Armenia	FI	Finland	LT	Lithuania	SK	Slovakia
AT	Austria	FR	France	LU	Luxembourg	SN	Senegal
AU	Australia	GA	Gabon	LV	Latvia	SZ	Swaziland
AZ	Azerbaijan	GB	United Kingdom	MC	Monaco	TD	Chad
BA	Bosnia and Herzegovina	GE	Georgia	MD	Republic of Moldova	TG	Togo
BB	Barbados	GH	Ghana	MG	Madagascar	TJ	Tajikistan
BE	Belgium	GN	Guinea	MK	The former Yugoslav Republic of Macedonia	TM	Turkmenistan
BF	Burkina Faso	GR	Greece	ML	Mali	TR	Turkey
BG	Bulgaria	HU	Hungary	MN	Mongolia	TT	Trinidad and Tobago
BJ	Benin	IE	Ireland	MR	Mauritania	UA	Ukraine
BR	Brazil	IL	Israel	MW	Malawi	UG	Uganda
BY	Belarus	IS	Iceland	MX	Mexico	US	United States of America
CA	Canada	IT	Italy	NE	Niger	UZ	Uzbekistan
CF	Central African Republic	JP	Japan	NL	Netherlands	VN	Viet Nam
CG	Congo	KE	Kenya	NO	Norway	YU	Yugoslavia
CH	Switzerland	KG	Kyrgyzstan	NZ	New Zealand	ZW	Zimbabwe
CI	Côte d'Ivoire	KP	Democratic People's Republic of Korea	PL	Poland		
CM	Cameroon	KR	Republic of Korea	PT	Portugal		
CN	China	KZ	Kazakstan	RO	Romania		
CU	Cuba	LC	Saint Lucia	RU	Russian Federation		
CZ	Czech Republic	LI	Liechtenstein	SD	Sudan		
DE	Germany	LK	Sri Lanka	SE	Sweden		
DK	Denmark	LR	Liberia	SG	Singapore		
EE	Estonia						

ELECTROCHEMICAL CELL HAVING LOW PROFILE SEAL ASSEMBLY

The present invention generally relates to an electrochemical cell construction.
5 More particularly, the present invention relates to the containers and collector assemblies used for an electrochemical cell, such as an alkaline cell.

Figure 1 shows the construction of a conventional C sized alkaline cell 10. As shown, cell 10 includes a cylindrically shaped can 12 having an open end and a closed
10 end. Can 12 is preferably formed of an electrically conductive material, such that an outer cover 11 welded to a bottom surface 14 at the closed end of can 12 serves as an electrical contact terminal for the cell.

Cell 10 further typically includes a first electrode material 15, which may serve
15 as the positive electrode (also known as a cathode). The first electrode material 15 may be preformed and inserted into can 12, or may be moulded in place so as to contact the inner surfaces of the can 12. For an alkaline cell, first electrode material 15 will typically include MnO_2 . After the first electrode 15 has been provided in can 12, a separator 17 is inserted into the space defined by first electrode 15. Separator 17 is
20 preferably a non-woven fabric. Separator 17 is provided to maintain a physical separation of the first electrode material 15 and a mixture of electrolyte and a second electrode material 20 while allowing the transport of ions between the electrode materials.

25 Once separator 17 is in place within the cavity defined by first electrode 15, an electrolyte is dispensed into the space defined by separator 17, along with the mixture 20 of electrolyte and a second electrode material, which may be the negative electrode (also known as the anode). The electrolyte/second electrode mixture 20 preferably includes a gelling agent. For a typical alkaline cell, mixture 20 is formed of a mixture of
30 an aqueous KOH electrolyte and zinc, which serves as the second electrode material. Water and additional additives may also be included in mixture 20.

Once the first electrode 15, separator 17, the electrolyte, and mixture 20 have been formed inside can 12, a preassembled collector assembly 25 is inserted into the open end of can 12. Can 12 is typically slightly tapered at its open end. This taper serves to support the collector assembly in a desired orientation prior to securing it in place. After collector assembly 25 has been inserted, an outer cover 45 is placed over collector assembly 25. Collector assembly 25 is secured in place by radially squeezing the can against collector assembly 25. The end edge 13 of can 12 is crimped over the peripheral lip of collector assembly 25, thereby securing outer cover 45 and collector assembly 25 within the end of can 12. As described further below, one function served by collector assembly 25 is to provide for a second external electrical contact for the electrochemical cell. Additionally, collector assembly 25 must seal the open end of can 12 to prevent the electrochemical materials therein from leaking from this cell. Additionally, collector assembly 25 must exhibit sufficient strength to withstand the physical abuse to which batteries are typically exposed. Also, because electrochemical cells may produce hydrogen gas, collector assembly 25 may allow internally generated hydrogen gas to permeate therethrough to escape to the exterior of the electrochemical cell. Further, collector assembly 25 should include some form of pressure relief mechanism to relieve pressure produced internally within the cell should this pressure become excessive. Such conditions may occur when the electrochemical cell internally generates hydrogen gas at a rate that exceeds that at which the internally generated hydrogen gas can permeate through the collector assembly to the exterior of the cell.

The collector assembly 25 shown in Figure 1 includes a seal 30, a collector nail 40, an inner cover 44, a washer 50, and a plurality of spurs 52. Seal 30 is shown as including a central hub 32 having a hole through which collector nail 40 is inserted. Seal 30 further includes a V-shaped portion 34 that may contact an upper surface 16 of first electrode 15.

Seal 30 also includes a peripheral upstanding wall 36 that extends upward along the periphery of seal 30 in an annular fashion. Peripheral upstanding wall 36 not only serves as a seal between the interface of collector assembly 25 and can 12, but also

serves as an electrical insulator for preventing an electrical short from occurring between the positive can and negative contact terminal of the cell.

Inner cover 44, which is formed of a rigid metal, is provided to increase the rigidity and support the radial compression of collector assembly 25 thereby improving the sealing effectiveness. As shown in Figure 1, inner cover 44 is configured to contact central hub portion 32 and peripheral upstanding wall 36. By configuring collector assembly 25 in this fashion, inner cover 44 serves to enable compression of central hub portion 32 by collector nail 40 while also supporting compression of peripheral upstanding wall 36 by the inner surface of can 12.

Outer cover 45 is typically made of a nickel-plated steel and is configured to extend from a region defined by the annular peripheral upstanding wall 36 of seal 30 and to be in electrical contact with a head portion 42 of collector nail 40. Outer cover 45 may be welded to head portion 42 of collector nail 40 to prevent any loss of contact. As shown in Figure 1, when collector assembly 25 is inserted into the open end of can 12, collector nail 40 penetrates deeply within the electrolyte/second electrode mixture 20 to establish sufficient electrical contact therewith. In the example shown in Figure 1, outer cover 45 includes a peripheral lip 47 that extends upwardly along the circumference of outer cover 45. By forming peripheral upstanding wall 36 of seal 30 of a length greater than that of peripheral lip 47, a portion of peripheral upstanding wall 36 may be folded over peripheral lip 47 during the crimping process so as to prevent any portion of the upper edge 13 of can 12 from coming into contact with outer cover 45.

Seal 30 is preferably formed of nylon. In the configuration shown in Figure 1, a pressure relief mechanism is provided for enabling the relief of internal pressure when such pressure becomes excessive. Further, inner cover 44 and outer cover 45 are typically provided with apertures 43 that allow hydrogen gas to escape to the exterior of cell 10. The mechanism shown includes an annular metal washer 50 and a plurality of spurs 52 that are provided between seal 30 and inner cover 44. Each spur 52 includes a pointed end 53 that is pressed against a thin intermediate portion 38 of seal 30. Spurs 52 are biased against the lower inner surface of inner cover 44 such that when the

internal pressure of cell 10 increases and seal 30 consequently becomes deformed by pressing upward toward inner cover 44, the pointed ends 53 of spurs 52 penetrate through the thin intermediate portion 38 of seal 30 thereby rupturing seal 30 and allowing the escape of the internally-generated gas through apertures 43.

5

Although the above-described collector assembly 25 performs all the above-noted desirable functions satisfactorily, as apparent from its cross-sectional profile this particular collector assembly occupies a significant amount of space within the interior of the cell 10. It should be noted that the construction shown in Figure 1 is but one example of a cell construction. Other collector assemblies exist that may have lower profiles and hence occupy less space within the cell. However, such collector assemblies typically achieve this reduction in occupied volume at the expense of the sealing characteristics of the collector assembly or the performance and reliability of the pressure relief mechanism.

10
15

The measured external and internal volumes for several batteries that were commercially available at the priority date of this application are listed in the tables shown in Figures 2A and 2B. The tables list the volumes (cc) for D, C, AA, and AAA sized batteries. The collector assembly volume and the percentage of the total cell volume that constitutes the collector assembly volume is provided in Figure 2B for those commercially available batteries listed in Figure 2A. Also provided in Figure 2A is a percentage of the total cell volume that constitutes the internal volume that is available for containing the electrochemically active materials.

20
25

The "total cell volume" includes all of the volume, including any internal void spaces, of the battery. For the battery shown in Figure 1, the total volume ideally includes all of the cross-hatched area as shown in Figure 3A. The "internal volume" of the battery is represented by the cross-hatched area shown in Figure 3B. The "internal volume", as used herein, is that volume inside the cell or battery that contains the electrochemically active materials as well as any voids and chemically inert materials (other than the collector nail) that are confined within the sealed volume of the cell. Such chemically inert materials may include separators, conductors, and any inert

30

additives in the electrodes. As described herein, the term “electrochemically active materials” includes the positive and negative electrodes and the electrolyte. The “collector assembly volume” includes the collector nail, seal, inner cover, washer, spurs and any void volume between the bottom surface of the negative cover and the seal (indicated by the cross-hatched area in Figure 3C). The “container volume” includes the volume of the can, label, negative cover (outer cover 45), void volume between the label and negative cover, positive cover, and void volume between the positive cover and can (shown by the cross-hatched area in Figure 3D). If the label extends onto and into contact with the negative cover, the void volume present between the label and negative cover is included in the container volume, and therefore is also considered as part of the total volume. Otherwise, that void volume is not included in either of the container volume or the total volume.

It should be appreciated that the sum total of the “internal volume”, “collector assembly volume”, and “container volume” is equal to the “total volume”. Accordingly, the internal volume available for electrochemically active materials can be confirmed by measuring the collector assembly volume and container volume and subtracting the collector assembly volume and the container volume from the measured total volume of the battery.

Because the exterior dimensions of the electrochemical cell are generally fixed by the American National Standards Institute (ANSI) or other standards organisations, the greater the space occupied by the collector assembly, the less space that there is available within the cell for the electrochemical materials. Consequently, a reduction in the amount of electrochemical materials that may be provided within the cell results in a shorter service life for the cell. It is therefore desirable to maximise the interior volume within an electrochemical cell that is available for the electrochemically active components.

We have now found that this may be achieved by constructing an electrochemical cell where the space occupied by the collector assembly and the space

occupied by the container volume are minimised while still maintaining adequate sealing characteristics and allowing a reliable pressure relief mechanism.

Accordingly, in a first aspect, the present invention provides an electrochemical
5 cell comprising:

- a can for containing electrochemically active materials including at least positive and negative electrodes and an electrolyte, the can including an open end and a closed end;
- a first outer cover positioned across the open end of the can;
- a collector electrically coupled to the first outer cover and extending internally
10 within the can to electrically contact one of the positive and negative electrodes; and
- an annular seal having an L-shaped cross section disposed between the can and the first outer cover for electrically insulating the can from the first outer cover and creating a seal between the first outer cover and the can.

15 In a second aspect, the present invention provides a collector and seal assembly for an electrochemical cell, the collector and seal assembly comprising:

- a cover adapted to be positioned in an open end of a can containing electrochemically active cell materials including at least positive and negative electrodes and electrolyte;
- 20 a collector electrically coupled to the cover and adapted to extend internally within the can to electrically contact one of the positive and negative electrodes; and
- an annular seal having an L-shaped cross section for sealingly engaging the cover and adapted to electrically insulate the can from the cover and create a seal between the cover and the can.

25 In a third aspect, the present invention provides a method of preparing an electrochemical cell comprising the steps of:

- providing a can having an open end and a closed end and side walls extending between the open end and the closed end;
- 30 disposing electrochemically active materials in the can, the electrochemically active materials including at least positive and negative electrodes and an electrolyte;
- securing a collector to a first outer cover to define a collector/cover assembly;

securing an annular seal having an L-shaped cross section to the perimeter of the collector/cover assembly to define a collector/cover/seal assembly; and

disposing the collector/cover/seal assembly into the can so that the collector and the first outer cover are in electrical contact with one of the positive and negative
5 electrodes, thereby disposing the first outer cover into the open end of the can, such that the annular seal forms a seal between the first outer cover and the can.

Preferably, a pressure relief mechanism is formed in a surface of the can, more preferably in a surface at the closed end of the can.

10

Advantageously, by using an annular seal having an L-shaped cross section to electrically insulate the outer cover from the can, a collector assembly may be employed that has a significantly lower profile and thereby occupies significantly less space within an electrochemical cell. Furthermore, this arrangement may enable cell constructions
15 exhibiting lower water loss over time than prior assemblies, thereby increasing the cell's shelf life. An additional advantage of the invention is that a reliable pressure relief mechanism can be provided that does not occupy a significant percentage of the available cell volume. Yet another advantage is that the cell constructions may be simpler to manufacture and require less materials, thereby possibly having lower
20 manufacturing costs. Moreover, cell constructions are enabled that require less radial compressive force to be applied by the can to adequately seal the cell, thereby allowing for the use of a can having thinner side walls, and thus resulting in greater internal cell volume.

25 The present invention will be further understood by reference to the drawings, in which:

Figure 1 is a cross section of a conventional C sized alkaline electrochemical cell;

Figure 2A is a table showing the relative total battery volumes and internal cell
30 volumes available for electrochemically active materials, as measured for those batteries that were commercially available at the priority date of this application;

Figure 2B is a table showing the relative total battery volumes and collector assembly volumes as measured for those batteries that were commercially available as provided in Figure 2A;

5 Figures 3A-3D are cross sections of a conventional C sized alkaline electrochemical cell that illustrate the total battery and various component volumes;

Figure 4A is a cross section of a C sized alkaline electrochemical cell constructed in accordance with an embodiment of the present invention having a rollback cover, an annular L-shaped (J-shaped) seal, and a pressure relief mechanism formed in the can bottom surface;

10 Figure 4B is a cross section of the top portion of a C sized alkaline electrochemical cell constructed in accordance with an embodiment of the present invention having a rollback cover and including an L-shaped annular seal;

Figure 4C is an exploded perspective view of the electrochemical cell shown in Figure 4A illustrating assembly of the collector seal and cover assembly;

15 Figure 5 is a bottom view of a battery can having a pressure relief mechanism formed in the closed end of the can;

Figure 6 is a cross-sectional view taken along line X-X of the can vent shown in Figure 5;

20 Figure 7A is a table showing the calculated total and internal cell volume for various batteries constructed in accordance with the present invention; and

Figure 7B is a table showing the calculated total volume and collector assembly volume for various batteries constructed in accordance with the present invention.

25 As described above, a primary objective of the present invention is to increase the internal volume available in a battery for containing the electrochemically active materials, without detrimentally decreasing the reliability of the pressure relief mechanism provided in the battery and without increasing the likelihood that the battery would otherwise leak.

30 The electrochemical cell comprises a can for containing electrochemically active materials including at least positive and negative electrodes and an electrolyte, the can having an open end and a closed end, and side walls extending between the open end

and closed end; a first outer cover positioned across the open end of the can; a collector electrically coupled to the first outer cover and extending internally within the can to electrically contact one of the positive and negative electrodes; and an annular seal having an L-shaped cross section disposed between the can and the first outer cover for electrically insulating the can from the first outer cover and creating a seal between the first outer cover and the can. The seal may further include an extended vertical member to form a J-shaped cross section.

A pressure relief mechanism is preferably formed in a surface of the can, more preferably in the closed end of the can, for releasing internal pressure from within the can when the internal pressure becomes excessive. As a result, the known complex collector/seal assemblies may be replaced with a collector assembly in accordance with the present invention that consumes less volume and has fewer parts. Thus, a significant improvement in internal cell volume efficiency may be obtained.

The pressure relief mechanism is preferably formed by providing a groove in the surface of can. This groove may be formed, for example, by coining a bottom surface of the can, cutting a groove in the bottom surface, or moulding the groove in the bottom surface of the can at the time the positive electrode is moulded. For an AA sized battery, a suitable thickness of the metal at the bottom of the coined groove is approximately 50 μm (2 mils). For a D sized battery, a suitable thickness is approximately 75 μm (3 mils). The groove may be formed as an arc of approximately 300 degrees. By keeping the shape formed by the groove slightly open, the pressure relief mechanism will have an effective hinge.

The pressure relief mechanism is preferably positioned beneath an outer cover so as to prevent the electrochemical materials from dangerously spraying directly outward from the battery upon rupture. Also, if the battery were used in series with another battery such that the end of the positive terminal of the battery is pressed against the negative terminal of another battery, the provision of an outer cover over pressure relief mechanism allows the mechanism to bow outwardly under the positive protrusion and ultimately rupture. If no outer cover is present in such circumstances, the contact

between the two batteries may otherwise prevent the pressure relief mechanism from rupturing. Furthermore, if an outer cover is not provided over the pressure relief mechanism, the pressure relief mechanism at the positive end of the battery may be more susceptible to damage. The outer cover also shields the pressure relief mechanism
5 from the corrosive effects of the ambient environment and therefore reduces the possibility of premature venting and/or leaking. Thus, preferably the pressure relief mechanism is formed under an outer cover at the closed end of the battery can. The outer cover preferably serves as the positive external battery terminal.

10 The size of the area circumscribed by the groove is preferably selected such that upon rupture due to excessive internal pressure, the area within the groove may pivot at the hinge within the positive protrusion of the outer cover without interference from the outer cover. In general, the size of the area defined by the groove, as well as the selected depth of the groove, depends upon the diameter of the can and the pressure at
15 which the pressure relief mechanism is to rupture and allow internally-generated gases to escape.

The open end of the can is sealed by placing an annular seal, having either a J-shaped or an L-shaped cross section, in the open end of the can. Preferably, the seal is
20 of nylon, although other suitable materials could be used. An outer cover, preferably serving as the negative terminal, which preferably has a rolled back peripheral edge, is inserted within the seal. Subsequently the outer edge of the can may be crimped to hold the seal and cover in place. To help hold the seal in place, a bead is preferably formed around the circumference of the open end of the can. The seal is preferably coated with
25 a material such as asphalt to protect it from the electrochemically active materials and to provide a better seal.

The annular seal may be configured with a J-shaped cross section which includes an extended vertical wall at the outermost perimeter thereof, a shorter vertical wall at the
30 radially inward side of the seal and has a horizontal base member formed between the vertical walls. With the presence of the short vertical section, the annular seal is referred to herein as having either a J-shaped or L-shaped cross section. It should be

appreciated that the J-shaped seal could also be configured absent the short vertical section to form a plain L-shaped cross section.

The electrochemical cell may be assembled as follows. The can, preferably a
5 cylindrical can, is formed with side walls defining the open end and preferably a bead for receiving internally disposed battery materials prior to closure of the can. Disposed within the can are the active electrochemical cell materials including the positive and negative electrodes and the electrolyte, as well as the separator, and any additives. Together, the outer cover, with a collector fastened to the bottom surface of the cover,
10 and the annular seal, are assembled and inserted into the open end of the can to seal and close the can. The collector, preferably a nail, is preferably fastened to the bottom side of the outer cover by welding, such as via a spot weld. Together, the collector and cover are engaged with the seal to form a collector assembly, and the collector assembly is inserted in the can such that the preferably rolled back peripheral edge of the outer cover
15 is disposed against the inside wall of the annular seal above the bead, which supports the seal. The collector assembly is forcibly disposed within the open end of the can to snugly engage and close the can opening. Thereafter, the outer edge of the can is preferably crimped inward to axially force and hold the seal and outer cover in place.

20 Preferably, the inside surface of the outer cover and at least a top portion of the collector are coated with an anti-corrosion coating. The anti-corrosion coating includes materials that are electrochemically compatible with the anode. Examples of such electrochemically compatible materials include epoxy, Teflon[®], polyolefins, nylon, elastomeric materials, or any other inert materials, either alone or in combination with
25 other materials. The coating may be sprayed or painted on and preferably covers that portion of the inside surface of the outer cover and collector which is exposed to the active materials in the void region above the positive and negative electrodes of the cell. It should also be appreciated that the inside surface of the cover could be plated with tin, copper, or other similarly electrochemically compatible materials. By providing an anti-
30 corrosion coating, any corrosion of the outer cover and collector may be reduced and/or prevented, which advantageously reduces the amount of gassing which may otherwise

occur within the electrochemical cell. Reduction in gassing within the cell results in reduced internal pressure build-up.

In a further embodiment, the can may be formed to have the protrusion for the positive battery terminal formed directly in the closed end of the can. In this manner, the void space existing between the closed end of the can and the positive outer cover may be used to contain electrochemically active materials or otherwise provide space for the collection of gases, which otherwise must be provided within the cell. Although the increase in cell volume obtained by forming the protrusion directly in the bottom of the can is not provided in the table in Figure 7A, it will be appreciated by those skilled in the art that the internal volume is typically one percent greater than the volumes listed for the cells listed in the table which are formed with a separate cover.

In a further embodiment, a print layer may be applied directly onto the exterior surface of the battery can to provide a label. By applying the label directly onto the exterior of the can as a print layer, rather than with a label substrate, the internal volume of the cell may be further increased since one does not have to account for the thickness of a label substrate to construct a cell that meets the ANSI or other exterior size standards. By "directly" is meant that no label substrate is present between the print layer and the external surface of the battery can. Current label substrates have thicknesses on the order of 75 μm (3 mils). Because such label substrates overlap to form a seam running along the length of the battery, these conventional labels effectively add about 250 μm (10 mils) to the diameter and of 330 μm (13 mils) to the crimp height of the battery. As a result, the battery can must have a diameter that is selected to accommodate the thickness of the label seam in order to meet the ANSI or other size standards. However, by printing a lithographed label directly on the exterior surface of the can, the diameter of the can may be correspondingly increased approximately 250 μm (10 mils). Such an increase in the diameter of the can significantly increases the internal volume of the battery. Thus, the internal volume of the batteries with substrate labels could be further increased, for example by 2 percent (1.02 cc) for a D sized battery, 2.6 percent (0.65 cc) for a C sized battery, 3.9 percent

(0.202 cc) for an AA sized cell, and 5.5 percent (0.195 cc) for an AAA sized battery, if the labels were printed directly on the exterior of the can.

5 Labels may also be printed on the can using transfer printing techniques in which the label image is first printed on a transfer medium and then transferred directly onto the can exterior. Distorted lithography may also be used whereby intentionally distorted graphics are printed on flat material so as to account for subsequent stress distortions of the flat material as it is shaped into the tube or cylinder of the cell can.

10 Prior to printing the lithographed label, the exterior surface of the can is preferably cleaned. To enhance adherence of the print to the can, a base coat of primer may be applied to the exterior surface of the can. The print layer is then applied directly on top of the base coat on the can by known lithographic printing techniques. The label may further comprise an electrically insulating overcoat. A varnish overcoat is
15 preferably applied over the print layer to cover and protect the print layer, and also to serve as an electrically insulating layer. The printed label may be cured with the use of high temperature heating or ultraviolet radiation techniques.

20 With the use of the printed label, the thickness of the label may be significantly reduced compared with a conventional label on a substrate, to a maximum thickness of approximately 13 μm (0.5 mils). In a particular embodiment, the printed label has a base coat layer of a thickness in the range of about 2.5 to 5 μm (0.1 to 0.2 mil), a print layer of a thickness of approximately 2.5 μm (0.1 mil), and a varnish overcoat layer of a thickness in the range of about 2.5 to 5 μm (0.1 to 0.2 mil).

25

By reducing the label thickness, the can is able to be increased in diameter, thereby offering a further increase in available volume for active cell materials while maintaining a predetermined outside diameter of the battery.

30 As will be appreciated, through the use of the constructions noted above, a battery can may be made with thinner walls, on the order of 100-200 μm (4-8 mils), since the construction techniques outlined below do not require the thicker walls that are

required in conventional batteries to ensure a sufficient crimp and seal. Furthermore, a label may be lithographed directly onto the exterior surface of the battery can. By making the can walls thinner and lithographing the label directly onto the exterior of the can, the internal volume of the cell may be further increased since one does not have to
5 account for the thickness of the label substrate to construct a cell that meets the ANSI exterior size standards.

While the present invention has been described above as having primary applicability to alkaline batteries, it will be appreciated by those skilled in the art that
10 similar benefits may be obtained by employing the inventive constructions in batteries utilising other electrochemical systems. For example, the inventive constructions may be employed in primary systems such as carbon-zinc and lithium based batteries and in rechargeable batteries, such as NiCd, metal hydride, and Li based batteries.
Furthermore, certain constructions of the present invention may be used in raw cells
15 (*i.e.*, cells without a label as used in battery packs or multi-cell batteries). Additionally, although the present invention has been described above in connection with cylindrical batteries, certain constructions of the present invention may be employed in constructing prismatic cells.

20 The present invention will now be further described by reference to the embodiments shown in Figures 4A to 6:

Figures 4A through 4C show embodiments according to the present invention, of an electrochemical battery 300. As shown in Figures 4A, 4B, 5, and 6, a pressure relief
25 mechanism 370 is formed by providing a groove 372 in the bottom surface of can 312. The pressure relief mechanism 370 is positioned beneath outer cover 311. As shown in Figures 4A and 4B, the open end of can 312 is sealed by placing either a nylon seal 330 having a J-shaped cross section or a nylon seal 330' having an L-shaped cross section in the open end of can 312, inserting a negative outer cover 345 having a rolled back
30 peripheral edge 347 within nylon seal 330 or 330', and subsequently crimping the outer edge 313 of can 312 to hold seal 330 or 330' and cover 345 in place. To help hold seal 330 or 330' in place, a bead 316 is formed around the circumference of the open end of

can 312. Nylon seal 330 or 330' is coated with asphalt to protect it from the electrochemically active materials and to provide a better seal.

Referring particularly to Figures 4A and 4C, the annular nylon seal 330 is shown
5 configured with a J-shaped cross section which includes an extended vertical wall 332 at the outermost perimeter thereof, a shorter vertical wall 336 at the radially inward side of the seal and has a horizontal base member 334 formed between the vertical walls 332 and 336. With the presence of the short vertical section 336, the annular seal is referred to herein as having either a J-shaped or L-shaped cross section. The J-shaped nylon seal
10 330 may also be configured absent the short vertical section 336 to form a plain L-shaped cross section as shown in Figure 4B.

With particular reference to Figure 4C, the assembly of the electrochemical cell shown in Figure 4A is illustrated therein. The cylindrical can 312 is formed with side
15 walls defining the open end and bead 316 for receiving internally disposed battery materials prior to closure of the can. Disposed within can 312 are the active electrochemical cell materials including the positive and negative electrodes and the electrolyte, as well as the separator, and any additives. Together, the outer cover 345, with the collector nail 340 welded to the bottom surface of cover 345, and annular nylon
20 seal 330 are assembled and inserted into the open end of can 312 to seal and close can 312. The collector nail 340 is welded via spot weld 342 to the bottom side of outer cover 345. Together, collector nail 340 and cover 345 are engaged with seal 330 to form the collector assembly, and the collector assembly is inserted in can 312 such that the rolled back peripheral edge 347 of outer cover 345 is disposed against the inside
25 wall of annular seal 330 above bead 316 which supports seal 330. The collector assembly is forcibly disposed within the open end of can 312 to snugly engage and close the can opening. Thereafter, the outer edge 313 of can 12 is crimped inward to axially force and hold seal 330 and outer cover 345 in place.

30 Referring back to Figure 4B, the inside surface of outer cover 345 and at least a top portion of collector nail 340 are further shown coated with an anti-corrosion coating 344. Anti-corrosion coating 344 includes materials that are electrochemically

compatible with the anode. Coating 344 may be sprayed or painted on and preferably covers that portion of the inside surface of outer cover 345 and collector nail 340 which is exposed to the active materials in the void region above the positive and negative electrodes of the cell. By providing the anti-corrosion coating 344, any corrosion of the
5 outer cover 345 and collector nail 340 is reduced and/or prevented.

It will be understood that the embodiments shown in the drawings and described above are merely for illustrative purposes and not intended to limit the scope of the invention.

10

EXAMPLE

The total battery volume, collector assembly volume, and internal volume available for electrochemically active material for each battery are determined by
15 viewing a Computer Aided Design (CAD) drawing, a photograph, or an actual cross section of the battery which has been encased in epoxy and longitudinally cross-sectioned. The use of a CAD drawing, photograph, or actual longitudinal cross section to view and measure battery dimensions allows for inclusion of all void volumes that might be present in the battery. To measure the total battery volume, the cross-sectional
20 view of the battery taken through its central longitudinal axis of symmetry is viewed and the entire volume is measured by geometric computation. To measure the internal volume available for electrochemically active materials, the cross-sectional view of the battery taken through its central longitudinal axis of symmetry is viewed, and the components making up the internal volume, which includes the electrochemically active
25 materials, void volumes and chemically inert materials (other than the collector nail) that are confined within the sealed volume of the cell, are measured by geometric computation. Likewise, to determine volume of the collector assembly, the cross-sectional view of the battery taken through its central longitudinal axis of symmetry thereof is viewed, and the components making up the collector assembly volume, which
30 include the collector nail, seal, inner cover, and any void volume defined between the bottom surface of the negative cover and the seal, are measured by geometric computation. The container volume may likewise be measured by viewing the central

longitudinal cross section of the battery and computing the volume consumed by the can, label, negative cover, void volume between the label and negative cover, positive cover, and void volume between the positive cover and the can.

5 The volume measurements are made by viewing a cross section of the battery taken through its longitudinal axis of symmetry. This provides for an accurate volume measurement, since the battery and its components are usually axial symmetric. To obtain a geometric view of the cross section of a battery, the battery was first potted in epoxy and, after the epoxy solidified, the potted battery and its components were ground
10 down to the central cross section through the axis of symmetry. More particularly, the battery was first potted in epoxy and then ground short of the central cross section. Next, all internal components such as the anode, cathode, and separator paper were removed in order to better enable measurement of the finished cross section. The potted battery was then cleaned of any remaining debris, was air dried, and the remaining void
15 volumes were filled with epoxy to give the battery some integrity before completing the grinding and polishing to its centre. The battery was again ground and polished until finished to its central cross section, was thereafter traced into a drawing, and the volumes measured therefrom.

20 Prior to potting the battery in epoxy, battery measurements were taken with callipers to measure the overall height, the crimp height, and the outside diameter at the top, bottom, and centre of the battery. In addition, an identical battery was disassembled and the components thereof were measured. These measurements of components of the disassembled battery include the diameter of the current collector nail, the length of the
25 current collector nail, the length of the current collector nail to the negative cover, and the outside diameter of the top, bottom, and centre of the battery without the label present.

30 Once the battery was completely potted in epoxy and ground to centre through the longitudinal axis of symmetry, the cross-sectional view of the battery was used to make a drawing. A Mitutoyo optical comparator with QC-4000 software was used to trace the contour of the battery and its individual components to generate a drawing of

the central cross section of the battery. In doing so, the battery was securely fixed in place and the contour of the battery parts were saved in a format that could later be used in solid modelling software to calculate the battery volumes of interest. However, before any volume measurements were taken, the drawing may be adjusted to

5 compensate for any battery components that are not aligned exactly through the centre of the battery. This may be accomplished by using the measurements that were taken from the battery before cross sectioning the battery and those measurements taken from the disassembled identical battery. For example, the diameter and length of the current collector nail, and overall outside diameter of the battery can be modified to profile the

10 drawing more accurately by adjusting the drawing to include the corresponding known cross-sectional dimensions to make the drawing more accurate for volume measurements. The detail of the seal, cover, and crimp areas were used as they were drawn on the optical comparitor.

15 To calculate the volume measurements, the drawing was imported into solid modelling software. A solid three-dimensional volume representation was generated by rotating the contour of the cross section on both the left and right sides by one-hundred-eighty degrees (180°) about the longitudinal axis of symmetry. Accordingly, the volume of each region of interest is calculated by the software and, by rotating the left and right

20 sides by one-hundred-eighty degrees (180°) and summing the left and right volumes together an average volume value is determined, which may be advantageous in those situations where the battery has non-symmetrical features. The volumes which include any non-symmetrical features can be adjusted as necessary to obtain more accurate volume measurements.

25

Figures 7A and 7B show volumes of various different types of battery constructions that are more fully disclosed in US 60/102,951 filed 2 October 1998 and US 60/097,445 filed 21 August 1998. As shown in Figure 7A in the rows referenced

“Pressure Relief in Can Bottom” and “Pressure Relief in Can Bottom With Thin Walls,”

30 a D sized battery constructed using the construction shown in Figure 4A, has an internal volume that is 93.5 volume percent when the can walls are 250 μm (10 mils) thick, and an internal volume that is 94.9 volume percent when the can walls are 200 μm (8 mils)

thick. As shown in Figure 7B, a D sized battery constructed using the construction shown in Figure 4A, has a collector assembly volume that is 2 percent of the total volume when the can walls are 250 μm (10 mils) thick and 200 μm (8 mils) thick. The C, AA, and AAA sized batteries having similar construction also exhibited significant
5 improvements in internal volume efficiency, as is apparent from the table in Figures 7A.

CLAIMS:

1. An electrochemical cell comprising:
a can for containing electrochemically active materials including at least positive
5 and negative electrodes and an electrolyte, the can including an open end and a closed end;
a first outer cover positioned across the open end of the can;
a collector electrically coupled to the first outer cover and extending internally
within the can to electrically contact one of the positive and negative electrodes; and
an annular seal having an L-shaped cross section disposed between the can and the
10 first outer cover for electrically insulating the can from the first outer cover and creating a
seal between the first outer cover and the can.
2. An electrochemical cell according to claim 1, wherein a pressure relief mechanism
is formed in a surface of the can for releasing internal pressure from within the can when
15 the internal pressure becomes excessive.
3. An electrochemical cell according to claim 2, wherein the pressure relief
mechanism includes a groove formed in the closed end of the can.
- 20 4. An electrochemical cell according to claim 2 or claim 3, further comprising a
second outer cover positioned on the closed end of the can in electrical contact therewith,
wherein the second outer cover overlies the pressure relief mechanism.
5. An electrochemical cell according to claim 4, wherein the second outer cover is
25 electrically coupled to the positive electrode to serve as a positive external battery terminal
and the first outer cover is electrically coupled to the negative electrode to serve as a
negative external battery terminal.
6. An electrochemical cell according to any preceding claim, wherein the first outer
30 cover has a rollback edge formed at the outer perimeter edge.

7. An electrochemical cell according to any preceding claim, wherein the annular seal further includes a vertical member to form a J-shaped cross section.
8. An electrochemical cell according to any preceding claim, wherein the collector
5 comprises a nail.
9. An electrochemical cell according to any preceding claim, further comprising a protective coating coated on an inner surface of the first outer cover, the coating comprised of an electrochemically compatible material.
- 10
10. An electrochemical cell according to claim 9, wherein the coating further extends at least partially on one end of the collector coupled to the first outer cover.
11. An electrochemical cell according to any preceding claim, wherein the annular seal
15 comprises nylon.
12. An electrochemical cell according to any preceding claim, wherein the annular seal further includes an extended vertical member to form a J-shaped cross section.
- 20 13. An electrochemical cell according to any preceding claim, comprising a protective coating extending at least partially on an inside surface of the first outer cover, the protective coating including an electrochemically compatible material for reducing corrosion and gassing within the electrochemical cell.
- 25 14. An electrochemical cell according to claim 13, wherein the coating comprises a material selected from epoxy, Teflon®, polyolefin, nylon, elastomeric material, and mixtures thereof.
15. An electrochemical cell according to any preceding claim, wherein the cell is a
30 cylindrical cell.

16. A collector and seal assembly for an electrochemical cell, the collector and seal assembly comprising:
- a cover adapted to be positioned in an open end of a can containing electrochemically active cell materials including at least positive and negative electrodes and electrolyte;
 - a collector electrically coupled to the cover and adapted to extend internally within the can to electrically contact one of the positive and negative electrodes; and
 - an annular seal having an L-shaped cross section for sealingly engaging the cover and adapted to electrically insulate the can from the cover and create a seal between the cover and the can.
17. An assembly according to claim 16, wherein the cover has a rollback edge formed at an outer perimeter edge thereof.
18. An assembly according to claim 16 or claim 17, wherein the annular seal further includes an extended vertical member to form a J-shaped cross section.
19. An assembly according to any of claims 16 to 18, wherein the collector comprises a nail.
20. An assembly according to any of claims 16 to 19, wherein the annular seal comprises nylon.
21. A method of assembling an electrochemical cell comprising the steps of:
- providing a can having an open end and a closed end and side walls extending between the open end and the closed end;
 - disposing electrochemically active materials in the can, the electrochemically active materials including at least positive and negative electrodes and an electrolyte;
 - securing a collector to a first outer cover to define a collector/cover assembly;
 - securing an annular seal having an L-shaped cross section to the perimeter of the collector/cover assembly to define a collector/cover/seal assembly; and

disposing the collector/cover/seal assembly into the can so that the collector and the first outer cover are in electrical contact with one of the positive and negative electrodes, thereby disposing the first outer cover into the open end of the can, such that the annular seal forms a seal between the first outer cover and the can.

5

22. A method according to claim 21, further comprising the step of crimping side walls of the can radially inward at the open end.

23. A method according to claim 21 or claim 22, further comprising the step of providing a pressure relief mechanism formed in a surface at the closed end of the can for releasing internal pressure from within the can when the internal pressure becomes excessive.

24. A method according to claim 23, wherein the step of providing the pressure relief mechanism includes forming a groove in the closed end of the can.

25. A method according to claim 23 or claim 24, further comprising the step of connecting a second outer cover positioned on the closed end of the can in electrical contact therewith, wherein the second outer cover overlies the pressure relief mechanism.

20

26. A method according to any of claims 21 to 25, further comprising the step of forming a rollback edge at the outer perimeter edge of the first outer cover.

27. A method according to any of claims 21 to 26, further comprising the step of forming the annular seal to include an extended vertical member to provide a J-shaped cross section.

28. A method according to any of claims 21 to 27, further comprising the step of applying a protective coating on an inner surface of the first outer cover, the coating being comprised of an electrochemically compatible material.

30

29. A method according to claim 28, wherein the step of applying a protective coating comprises applying a material selected from epoxy, Teflon®, polyolefin, nylon, elastomeric material, and mixtures thereof.

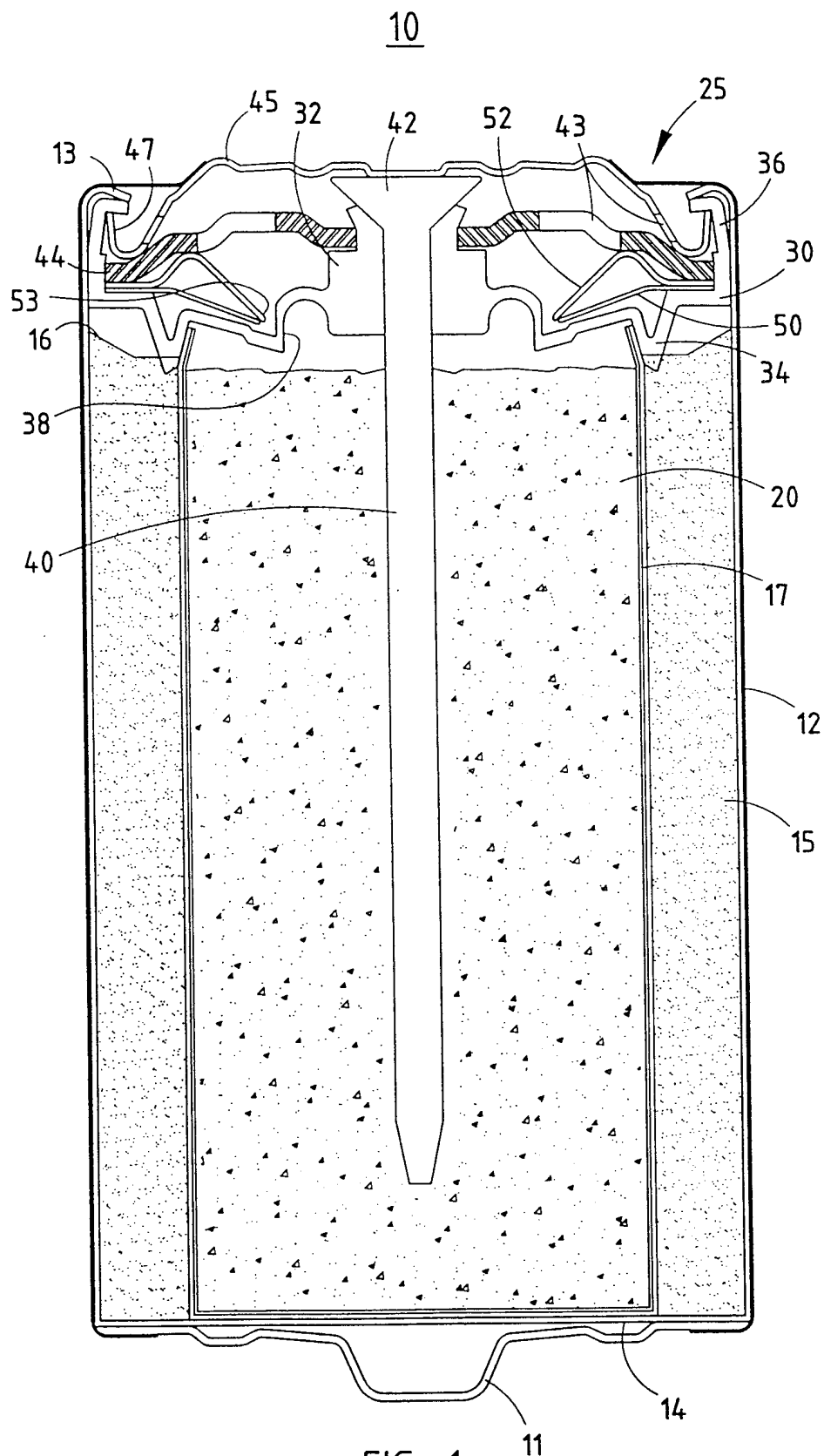

FIG. 1

D		C			AA			AAA			
Total Vol (cc)	Int Vol (cc)	%	Total Vol (cc)	Int Vol (cc)	%	Total Vol (cc)	Int Vol (cc)	%	Total Vol (cc)	Int Vol (cc)	%
50.38	44.16	87.7%	23.22	19.37	83.4%	7.43	6.05	81.4%	3.65	2.67	73.2%
48.19	41.48	86.1%	23.30	18.95	81.3%	7.62	6.12	80.3%	3.44	2.62	76.2%
48.36	40.59	83.9%	23.53	19.09	81.1%	7.20	5.84	81.1%	3.55	2.66	74.9%

FIG. 2A

D		C		AA		AAA		
Total Vol (cc)	Collector Ass'y Vol (cc)	%	Total Vol (cc)	Collector Ass'y Vol (cc)	%	Total Vol (cc)	Collector Ass'y Vol (cc)	%
50.38	2.51	5.0%	23.22	1.72	7.4%	7.43	0.52	7.0%
48.19	3.43	7.1%	23.30	2.01	8.6%	7.62	0.50	6.6%
48.36	3.80	7.9%	23.53	2.05	8.7%	7.20	0.53	7.4%
						3.65	0.32	8.8%
						3.44	0.29	8.4%
						3.55	0.30	8.5%

FIG. 2B

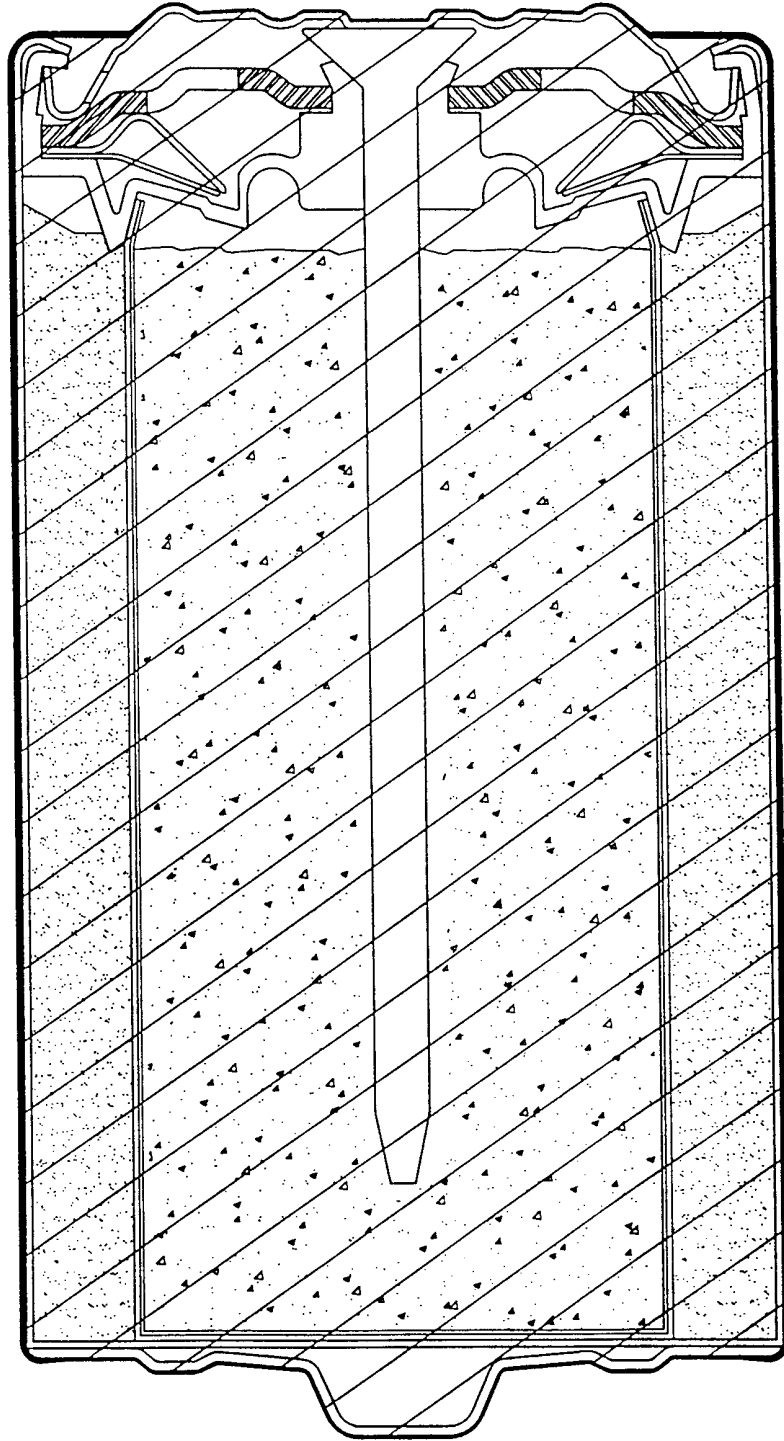

FIG. 3A

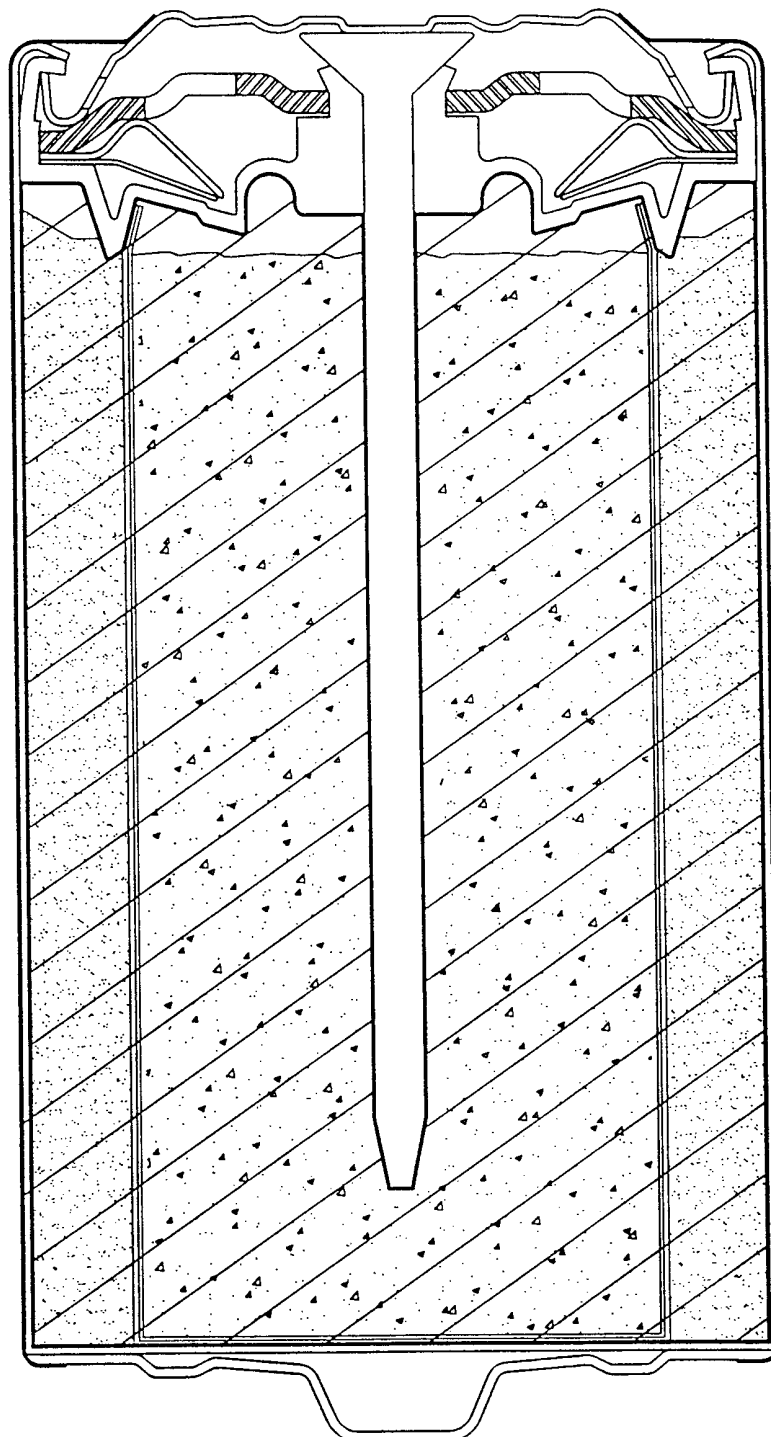

FIG. 3B

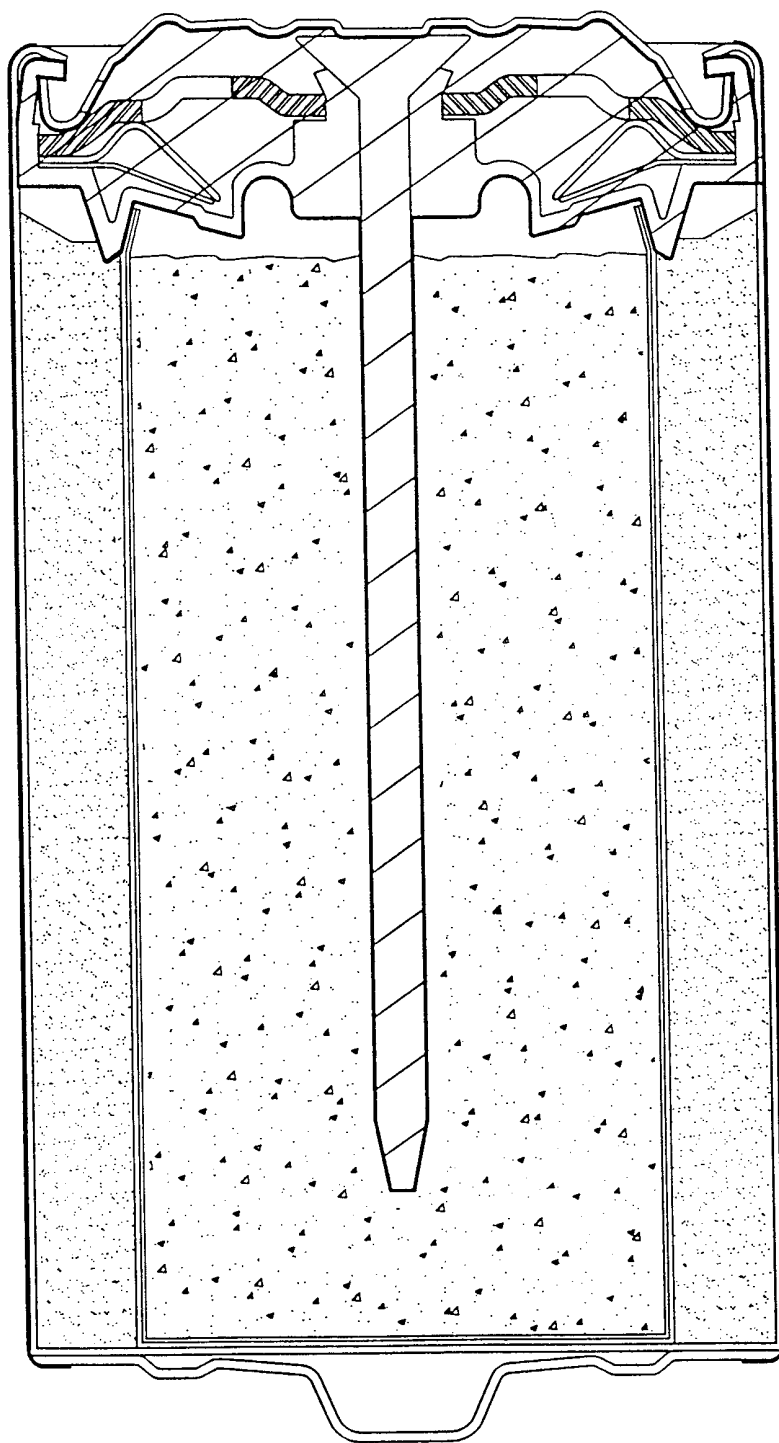

FIG. 3C

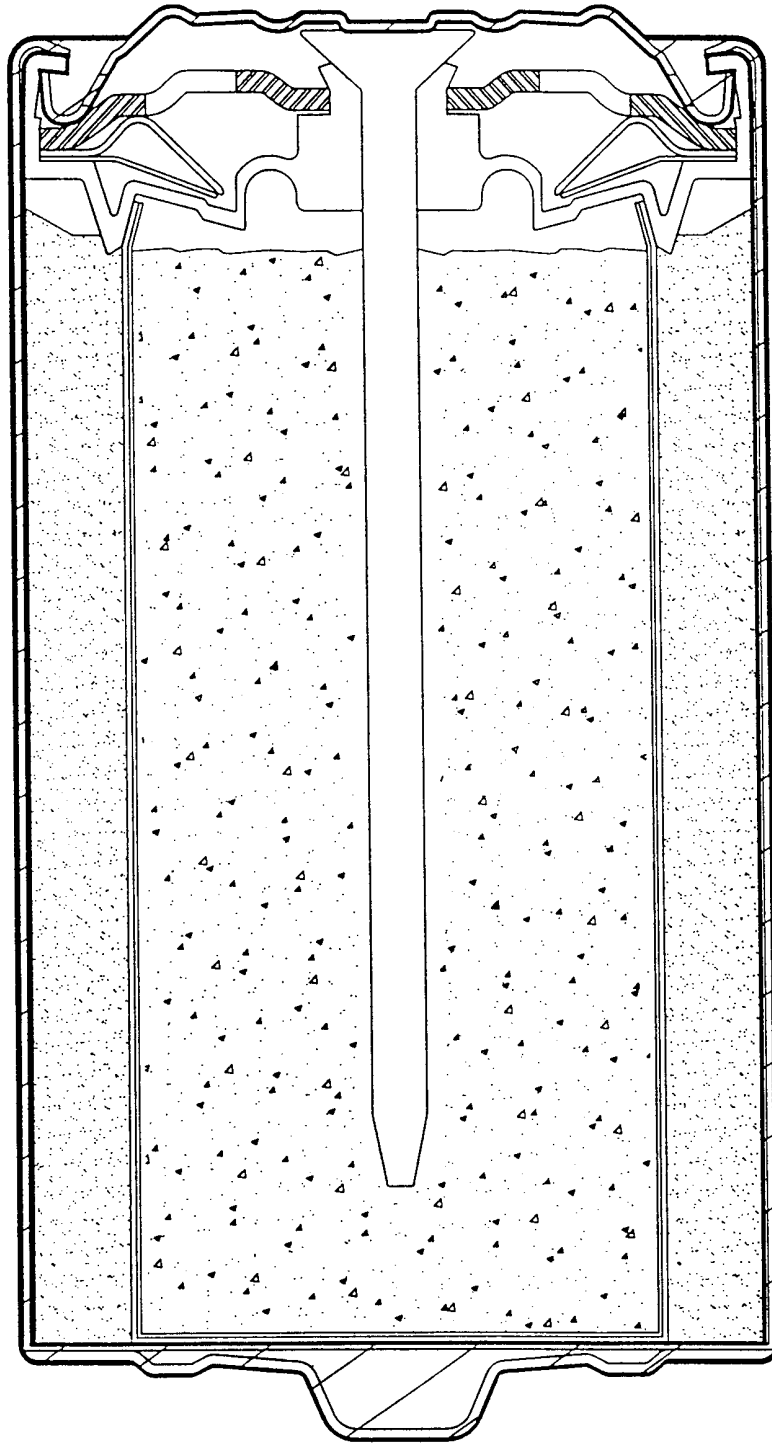
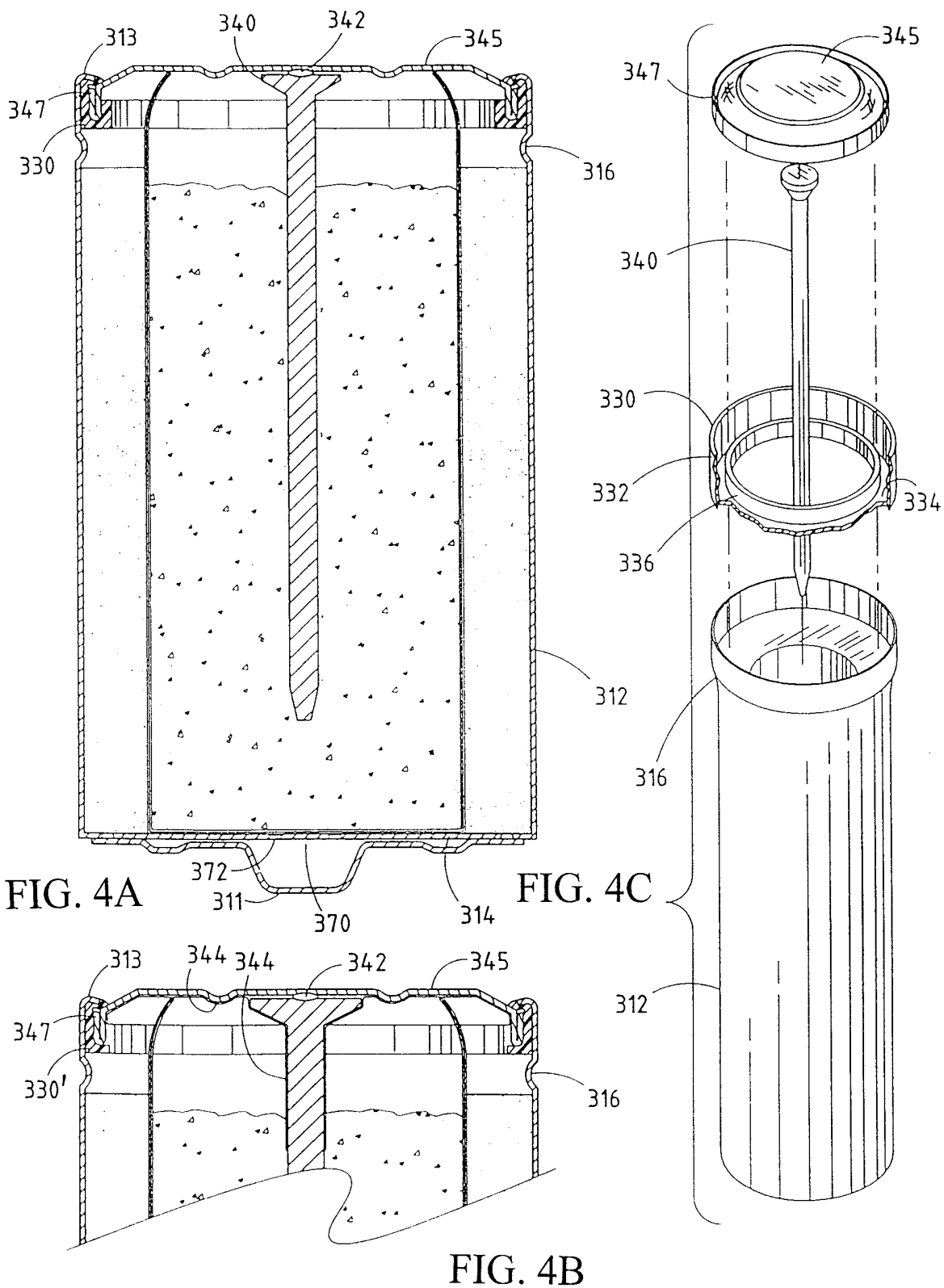

FIG. 3D



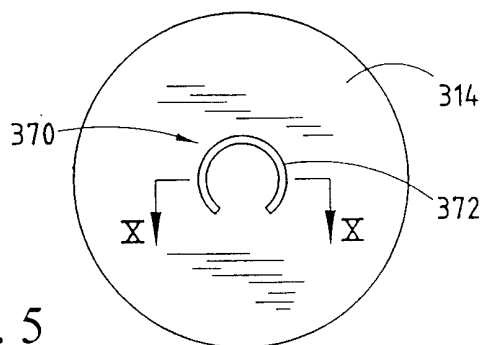

FIG. 5

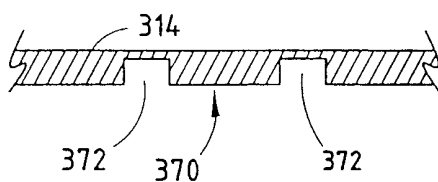

FIG. 6

	D**				C***				AA				AAA			
	Walls	Total Volume (cc)	Collector Assy Vol (cc)	%	Walls	Total Volume (cc)	Collector Assy Vol (cc)	%	Walls	Total Volume (cc)	Collector Assy Vol (cc)	%	Walls	Total Volume (cc)	Collector Assy Vol (cc)	%
Low Profile Seal	10 mil	50.07	2.65	5.3%	10 mil	24.57	1.81	7.4%	8 mil	7.75	0.36	4.6%	8 mil	3.57	0.24	6.7%
Ultra Low Profile Seal	10 mil	50.07	1.89	3.8%	10 mil	24.57	1.10	4.5%	8 mil	7.75	0.25	3.2%	8 mil	3.57	0.15	4.1%
Ultra Low Profile Seal w/Thin Can Walls	8 mil	50.07	1.70	3.4%	8 mil	24.57	0.97	3.9%	6 mil	7.75	0.19	2.5%	6 mil	3.57	0.12	3.4%
Pressure Relief In Can Bottom	10 mil	50.07	1.00	2.0%	10 mil	24.57	0.75	3.1%	8 mil	7.75	0.13	1.6%	8 mil	3.57	0.06	1.7%
Pressure Relief In Can Bottom w/Thin Walls	8 mil	50.07	1.00	2.0%	8 mil	24.57	0.75	3.1%	6 mil	7.75	0.13	1.6%	6 mil	3.57	0.06	1.7%
Beverage Can-Type Construction*	8 mil	50.07	0.78	1.6%	8 mil	24.57	0.63	2.6%	6 mil	7.75	0.07	0.9%	6 mil	3.57	0.06	1.6%
Beverage Can With Feed Through Collector*	8 mil	50.07	1.30	2.6%	8 mil	24.57	0.88	3.6%	6 mil	7.75	0.15	1.9%	6 mil	3.57	0.09	2.6%

* Utilizes a lithographed label directly on the can -- all other constructions use a shrink wrap label.

** All the D size cells were constructed with a recessed negative cover.

** All the C size cells were constructed with a recessed negative cover and have a 10 mil diameter increase over the prior C size Energizer cells.

FIG. 7B

INTERNATIONAL SEARCH REPORT

Inte. onal Application No

PCT/US 99/18606

A. CLASSIFICATION OF SUBJECT MATTER
 IPC 7 H01M2/08 H01M2/12 H01M2/32

According to International Patent Classification (IPC) or to both national classification and IPC

B. FIELDS SEARCHED

Minimum documentation searched (classification system followed by classification symbols)
 IPC 7 H01M

Documentation searched other than minimum documentation to the extent that such documents are included in the fields searched

Electronic data base consulted during the International search (name of data base and, where practical, search terms used)

C. DOCUMENTS CONSIDERED TO BE RELEVANT

Category °	Citation of document, with indication, where appropriate, of the relevant passages	Relevant to claim No.
X	US 4 822 377 A (WOLFF MERLE) 18 April 1989 (1989-04-18)	1, 2, 16, 17, 21, 22, 27
Y	claims 1-5; figures 1-5	3-5, 7-9, 13-15, 18, 19, 23, 24, 28, 29
Y	US 4 942 101 A (AUDEBERT JEAN F ET AL) 17 July 1990 (1990-07-17) claims 1-8; figures 1-4	8, 19
Y	FR 2 627 327 A (ACCUMULATEURS FIXES) 18 August 1989 (1989-08-18) claims 1-5; figures 1-4	3-5, 23, 24
	-/-	

Further documents are listed in the continuation of box C. Patent family members are listed in annex.

° Special categories of cited documents :

<p>"A" document defining the general state of the art which is not considered to be of particular relevance</p> <p>"E" earlier document but published on or after the international filing date</p> <p>"L" document which may throw doubts on priority claim(s) or which is cited to establish the publication date of another citation or other special reason (as specified)</p> <p>"O" document referring to an oral disclosure, use, exhibition or other means</p> <p>"P" document published prior to the international filing date but later than the priority date claimed</p>	<p>"T" later document published after the international filing date or priority date and not in conflict with the application but cited to understand the principle or theory underlying the invention</p> <p>"X" document of particular relevance; the claimed invention cannot be considered novel or cannot be considered to involve an inventive step when the document is taken alone</p> <p>"Y" document of particular relevance; the claimed invention cannot be considered to involve an inventive step when the document is combined with one or more other such documents, such combination being obvious to a person skilled in the art.</p> <p>"&" document member of the same patent family</p>
--	--

Date of the actual completion of the international search	Date of mailing of the international search report
26 November 1999	03/12/1999

Name and mailing address of the ISA European Patent Office, P.B. 5818 Patentlaan 2 NL - 2280 HV Rijswijk Tel. (+31-70) 340-2040, Tx. 31 651 epo nl, Fax: (+31-70) 340-3018	Authorized officer Battistig, M
--	--

INTERNATIONAL SEARCH REPORT

International Application No

PCT/US 99/18606

C.(Continuation) DOCUMENTS CONSIDERED TO BE RELEVANT		
Category °	Citation of document, with indication, where appropriate, of the relevant passages	Relevant to claim No.
Y	EP 0 415 378 A (MATSUSHITA ELECTRIC IND CO LTD) 6 March 1991 (1991-03-06) claims 1-17; figures 4-7	7, 18
Y	US 4 136 438 A (MALLORY HENRY R) 30 January 1979 (1979-01-30) column 5, line 20 - line 28; claims 1-8; figure 1	9, 13-15, 28, 29
X	PATENT ABSTRACTS OF JAPAN vol. 014, no. 387 (E-0967), 21 August 1990 (1990-08-21) & JP 02 142057 A (SEIKO ELECTRONIC COMPONENTS LTD), 31 May 1990 (1990-05-31) abstract	1, 7
X	US 5 372 897 A (KOZAWA HIDEAKI ET AL) 13 December 1994 (1994-12-13) claims 1-9	1, 7

INTERNATIONAL SEARCH REPORT

Information on patent family members

International Application No

PCT/US 99/18606

Patent document cited in search report		Publication date	Patent family member(s)	Publication date
US 4822377	A	18-04-1989	NONE	
US 4942101	A	17-07-1990	FR 2634595 A CH 679712 A DE 3923787 A JP 2079372 A	26-01-1990 31-03-1992 01-02-1990 19-03-1990
FR 2627327	A	18-08-1989	NONE	
EP 0415378	A	06-03-1991	JP 2068393 C JP 3084852 A JP 7107840 B DE 69010116 D DE 69010116 T US 5156930 A	10-07-1996 10-04-1991 15-11-1995 28-07-1994 20-10-1994 20-10-1992
US 4136438	A	30-01-1979	US 4052537 A AU 2908077 A BE 859295 A CA 1078455 A CH 626748 A DE 2743566 A DK 434377 A FR 2366704 A GB 1590005 A IL 52965 A IT 1084550 B JP 1351377 C JP 53043829 A JP 61017101 B MX 143951 A NL 7710711 A SE 441482 B SE 7710969 A	04-10-1977 29-03-1979 01-02-1978 27-05-1980 30-11-1981 06-04-1978 02-04-1978 28-04-1978 28-05-1981 31-03-1981 25-05-1985 28-11-1986 20-04-1978 06-05-1986 05-08-1981 04-04-1978 07-10-1985 02-04-1978
JP 02142057	A	31-05-1990	NONE	
US 5372897	A	13-12-1994	JP 6044951 A JP 6231799 A JP 6260153 A JP 6267514 A US 5490867 A US 5537733 A	18-02-1994 19-08-1994 16-09-1994 22-09-1994 13-02-1996 23-07-1996