

(19) World Intellectual Property Organization  
International Bureau



(43) International Publication Date  
30 January 2003 (30.01.2003)

PCT

(10) International Publication Number  
**WO 03/009581 A1**

- (51) International Patent Classification<sup>7</sup>: **H04N 5/00**, 7/24
- (21) International Application Number: PCT/GB02/03307
- (22) International Filing Date: 19 July 2002 (19.07.2002)
- (25) Filing Language: English
- (26) Publication Language: English
- (30) Priority Data:  
01306206.2 19 July 2001 (19.07.2001) EP
- (71) Applicant (for all designated States except US): **BRITISH TELECOMMUNICATIONS PUBLIC LIMITED COMPANY** [GB/GB]; 81 Newgate Street, London EC1A 7AJ (GB).
- (72) Inventors; and
- (75) Inventors/Applicants (for US only): **JACOBS, Richard, James** [GB/GB]; 15 Through Duncans, Woodbridge, Suffolk IP12 4EA (GB). **WALKER, Matthew, David** [GB/GB]; 9 Thirlmere Court, Felixstowe, Suffolk IP11

9SN (GB). **MIRAS, Dimitrios** [GR/GR]; 12 Proti Parodos Avras, 24100 Kalamata (GR).

(74) Agent: **WILLIAMSON, Simeon, Paul**; 0T Group Legal, Intellectual Property Department, Holborn Centre 8th Floor, 120 Holborn, London EC1N 2TE (GB).

(81) Designated States (national): AE, AG, AL, AM, AT, AU, AZ, BA, BB, BG, BR, BY, BZ, CA, CH, CN, CO, CR, CU, CZ, DE, DK, DM, DZ, EC, EE, ES, FI, GB, GD, GE, GH, GM, HR, HU, ID, IL, IN, IS, JP, KE, KG, KP, KR, KZ, LC, LK, LR, LS, LT, LU, LV, MA, MD, MG, MK, MN, MW, MX, MZ, NO, NZ, OM, PH, PL, PT, RO, RU, SD, SE, SG, SI, SK, SL, TJ, TM, TN, TR, TT, TZ, UA, UG, US, UZ, VN, YU, ZA, ZM, ZW.

(84) Designated States (regional): ARIPO patent (GH, GM, KE, LS, MW, MZ, SD, SL, SZ, TZ, UG, ZM, ZW), Eurasian patent (AM, AZ, BY, KG, KZ, MD, RU, TJ, TM), European patent (AT, BE, BG, CH, CY, CZ, DE, DK, EE, ES, FI, FR, GB, GR, IE, IT, LU, MC, NL, PT, SE, SK, TR), OAPI patent (BF, BJ, CF, CG, CI, CM, GA, GN, GQ, GW, ML, MR, NE, SN, TD, TG).

[Continued on next page]

(54) Title: VIDEO STREAM SWITCHING

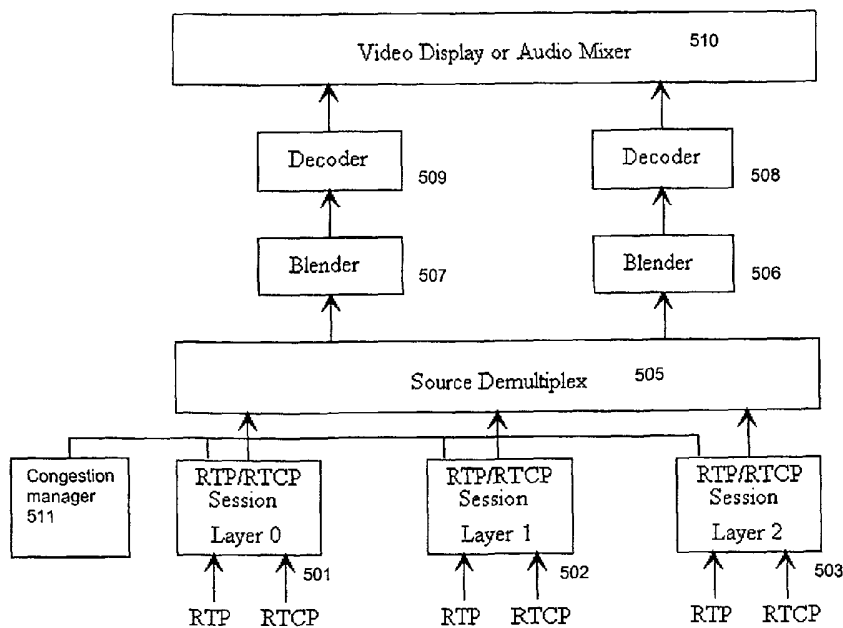

(57) Abstract: A technique is described for providing a client on a packet based network with a stream of encoded video data. The system is able to maximise the bit-rate of the video stream by adapting to fluctuations in network capacity. The technique is characterised in that adaptation of the bit-rate of the transmitted encoded video data is timed to occur upon a scene change in the video sequence. In this way the interruption to the viewer when the perceived quality of the video sequence increases or decreases is minimised as it is 'hidden' in the scene change. The technique is described as applied to hierarchically encoded video data but equally may be applied to other encoding techniques which adapt to network conditions.

WO 03/009581 A1



**Published:**

— *with international search report*

*For two-letter codes and other abbreviations, refer to the "Guidance Notes on Codes and Abbreviations" appearing at the beginning of each regular issue of the PCT Gazette.*

## Video Stream Switching

The invention is in the field of video streaming over packet networks and in particular concerns the adaptive transmission of data in response to network  
5 congestion.

In recent years, the Internet has experienced a proliferation in transmission of real-time multimedia, mainly in the form of streamed audio-visual content, either delivered live or from pre-recorded sources. Furthermore, traditional forms of  
10 multimedia such as streaming and conferencing are being followed by applications with richer content such as Internet multi-channel TV and complex immersive environments. This increase in traffic will put strains on the network and it is therefore desirable that application programs are designed to respond to congestion if stability of the network is to be maintained. It is desirable that  
15 network conditions are monitored and output bit-rates adjusted to the available bandwidth.

There is a more immediate advantage to the user in having an adaptive output bit-rate which is that the highest possible transmission bit-rate that the network  
20 will allow is used and therefore the user will always receive the best possible image quality. There are a number of known approaches to adaptive quality video streaming, one of which is hierarchical coding. In this technique the original video data is encoded into a number of discreet streams called layers, where the first layer consists of basic data of a relatively poor quality and where  
25 successive layers represent more detailed information so that layers can be added to increase the image quality or layers can be taken away, depending on the available bandwidth.

As the bit-rate available to a session is subject to significant variations in the  
30 number of layers that are transmitted, quality fluctuations occur in the decoded image as layers are added or dropped. When layers are added or dropped frequently the fluctuations in quality may become disturbing to a viewer.

In a first embodiment of the present invention there is provided a method of  
35 operating a multimedia server, said method comprising:

providing a stream of video data representing a video sequence to an output of the multimedia server, wherein the output of the media server is connected to a packet based network,

measuring a property of the video data in order to determine the  
5 occurrence of a scene change in the video sequence,  
detecting the available bandwidth on the network,  
varying the bit-rate of the stream of video data,  
wherein the method is characterised in that  
10 variation in the bit-rate of the video data is controlled to occur in response  
to variations in the capacity of the network (203) and preferentially with a scene  
change in the video sequence.

The term preferentially used herein is meant to indicate that in certain  
circumstances (discussed in greater detail below) it may not be practical to wait  
15 for a change of scene to occur in the video sequence before varying the bit-rate  
of the video stream, and in such circumstances the bit-rate will be changed at  
points in the video stream which do not correspond to a change of scene.

The term scene change (or change of scene) is intended to refer to a sudden  
20 change in a video sequence within the space of a one or a very few frames such  
as typically occurs at a change of scene, whether or not there has been an  
actual change of scene.

Embodiments of the present invention will now be described, by way of example  
25 only, with reference to the following figures, where;

Figure 1 is a schematic diagram of the content-based inter-stream session  
bandwidth sharing architecture.

Figure 2 shows the order of packets in a layered coding system.

Figure 3 is a diagram of a media server.

30 Figure 4 is a diagram of the network interface of the media server shown in  
Figure 3.

Figure 5 is a diagram of a client.

Figure 6 is a diagram of a client according to a first embodiment of the present  
invention.

35

The client/ server arrangement for a known hierarchical streaming technology is shown in Figure 1. A media server 202 is provided which has access to compressed audiovisual data 201, which may be fed 'live' from an outside broadcast or may be pre-compressed and stored in a database. The data source  
5 201 may be on the same premises as the media server 202 and linked via an intranet. The media server 202 runs on a suitable server computer and which has access to the Internet 203.

A video viewer, hitherto referred to as the client 204, running on a PC suitably configured to have access to the Internet 203, may connect to the media server  
10 202 via the Internet 203 and thus the client 204 is able to access content. A suitable PC terminal is used.

Layered video compression is achieved with the 1998 version of H.263 but equally may be any other codec, such as MPEG4. Each layer in the hierarchy is coded in such a way as to allow the quality of individual pictures to be enhanced  
15 and their resolution to be increased, and additional pictures to be included to increase the overall picture rate, as explained with reference to Figure 2. Figure 2 illustrates a typical dependency between pictures in an H.263 scalable layered coder, with the boxes representing the frames for each layer and arrows showing the dependency between frames. The lowest row shows original, un-  
20 coded frames. The next row shows the lowest layer (Layer 0) of the hierarchy which is coded at half the frame rate of Layer 1. Frames in Layer 0 are predicted from the previously encoded frame, as in conventional video compression.

Frames in Layer 1 may be predicted from the previously encoded frame in Layer 1 and, if present, the temporally simultaneous Layer 0 encoded frame. Frames in  
25 Layer 2 may be predicted from the previously encoded frame in Layer 2 and, if present, the temporally simultaneous Layer 1 or Layer 0 encoded frame. The H.263 specification allows for 15 layers; in the present embodiment server and client software is not limited in the number of layers that can be used, but in this case a database has been generated with video streams containing four layers.

30 Figure 3 shows the architecture of media server 201. In the present embodiment the audiovisual source is a database 301 of compressed video data and the media server 201 is responsible for reading the compressed data from a database, packetising and distributing it. The data is distributed according to the

Real-time Transport Protocol (RTP) which provides end-to-end network transport functions suitable for applications transmitting real-time data such as audio, video or simulation data. RTP does not address resource reservation and does not guarantee quality-of-service for real-time services. The data transport is  
5 augmented by a control protocol (RTCP) to allow monitoring of the data delivery and to provide minimal control and identification functionality. RTP and RTCP are designed to be independent of the underlying transport and network layers. The media server 201 has four major components: database reader 302, video RTP packetiser 303, audio RTP packetiser 305 and a network interface 304.  
10 Video and audio data are stored as files of compressed bits in the database 301. The database reader 302 retrieves and synchronises the compressed audio and video from the database 301.

The audio and video data is then sent to a RTP packetiser 303,305. Audio and  
15 video information is transmitted over the IP network using the User Datagram Protocol (UDP) and Real-time Transport Protocol (RTP) packetisation. UDP provides a checksum to detect transmission errors, but does not guarantee data delivery: packets may be lost, duplicated or re-ordered. RTP provides end-to-end delivery services, such as payload type identification, sequence numbering, time-  
20 stamping and delivery monitoring. RTP packetisers 303,305 attach the RTP Header and, in the case of video packets, the H.263 Payload Header which provides some protection from packet loss. The Payload Header contains information specific to the video stream, such as motion vector predictors, which is obtained by decoding the compressed bit stream.

25 The rate at which data is read from the database 301 is controlled from the network interface 304, which is illustrated in greater detail in Figure 4. With reference to Figure 4 the arrangement of the network interface 304 for the video data will now be described. A packet numbering module 401 assigns a number to each packet of data. These packet numbers are used by the client to  
30 assemble packets into the sequence required for decoding. The number of bits produced by compressing a picture is in general not constant, even when the transmission rate is constant. The first picture of a new scene will usually produce a larger number of bits than a picture where there is little movement or detail. The encoding process will use a control strategy together with an output  
35 data buffer to smooth these variations in preparation for transmission at a

constant bit rate. In the case of layered coding, each layer has its own control strategy and buffer as it has its own constant bit rate constraint to meet. The delay across each of these buffers will not be constant and will not be the same for each layer. Delay variation between the layers is therefore introduced at the source of the data. Transmission across a network may cause this delay variation to increase. A packet numbering scheme is therefore needed to ensure that a client can arrange the packets it receives into the order required for decoding. This scheme is required to handle the cases of the client not receiving all of the layers and of packet loss in the layers that it does receive.

Each layer is transmitted as an independent RTP Session on a separate IP address by a session handler 403, 405, 407, 409. The rate at which data is transmitted is controlled by the Transfer Rate Control module 402, which counts Layer 0 bytes to ensure that the correct number are transmitted in a given period of time. The transmission rate of the other layers is smoothed and locked to the rate of Layer 0 using First-In First-Out (FIFO) buffer elements 404, 406, 408.

The client 204 of the known hierarchical streaming technology will now be described with reference to Figure 5. Each RTP/RTCP Session associated with each layer of encoded data has a session handler 501, 502, 503, 504 at the client which is responsible for receiving RTP packets from the network. The packets are then passed to a source demultiplex module 505. This receives packets from all layers and all sources, demultiplexes them by source, and routes them to a blender module 506, 507 for that source. The blender module 506, 507 receives packets from all layers from one source in the order that they were received from the network. This may not be the order required for decoding because of packet inter-arrival jitter or packet loss. The blender module 506, 507 uses the packet numbers in the RTP headers to arrange the packets from each layer in order and then combines the packets from all layers together. The output of the blender module 506, 507 is a single stream of packets which are in the correct order for decoding. This is the same order as they come out of the packet numbering module 401 of the media server 202.

Packets are then sent to the decoder 508, 509 where the packets are decoded into 20ms blocks of audio samples or to video pictures. In the case of pictures, these are rendered to a window on the display 508.

5 Also provided is a congestion manager 511 to which the session handlers 501-504 report packet loss. If packets are being consistently lost, indicating network congestion, the congestion manager 511 will instruct the session handler responsible for the highest layer of compressed data to terminate the RTP/RTCP Session. Periodically the congestion manager 511 will instruct an experimental  
10 joining of a layer via the appropriate session handler to test whether there is available bandwidth in the network. If this experiment is successful, i.e. that substantially all of the packets of each layer are getting reaching the client, then the new layer will be adopted. In this way the maximum available bandwidth is employed.

15

It possible for the congestion manager 509 to instruct layers to be dropped and restored rapidly as the network bandwidth fluctuates. This could be annoying for a viewer and so a way of 'hiding' the shift is employed. The layered encoding method described above is adapted so that if a layer is to be dropped  
20 or added, the changeover preferentially occurs during a scene-change in the video data. A video scene is typically perceived as the number of consecutive frames within a video sequence that do not show significant changes in the video content. Within a video scene or shot, the camera action may be fixed or may exhibit a number of relatively uniform changes like panning, zooming,  
25 tracking etc. Scene changes may be recognised as abrupt transitions of the camera action or gradual transitions. In order to identify the scenes within a video sequence the assumption is that the levels of motion energy as well as those of luminance and colour do not change much between successive frames within a single scene. Techniques of scene boundary identification include pixel  
30 differencing, motion vector and block matching techniques. A very sudden change in the content of temporally adjacent frames will thus appear as a change of scene; clearly it is conceivable that such a change might not actually relate to a scene change at all, but, for example, may instead be the consequence of a large foreground object coming rapidly into view. However,  
35 such an abrupt change will nonetheless be a good place to add or remove a



session layer and thus the term scene change is meant to cover such large changes in frame content from one frame to another.

Figure 6 illustrates a system which detects congestion in the network and also  
5 imposes the extra condition of adding or dropping a layer upon a scene change.  
The server 601 comprises the components of the media server 202 of Figure 1  
and the unit 603 comprises the components of the client 204 also shown in  
Figure 1. Video data from the audiovisual source is also passed to a content  
10 analyser 604 which segments the video sequence into scenes. The segmented  
video is then passed to an objective quality assessment module (OQAM) 605  
which assesses the contribution to the perceived quality of a scene that each  
component layer provides.

These results are then passed to an inter layer adaptation module (ILAM) 607.  
15 The function of the ILAM 607 is to continuously calculate the number of layers  
that maximise the perceived quality for the session. The ILAM 607 also receives  
input from a sender congestion manager 608 which reports on the bandwidth  
available to the session on the network 203. The sender congestion manager  
608 receives feedback from a client congestion manager 609 on the number of  
20 packets that have been received. If this matches the number of packets that  
were sent then the bandwidth is known to be the current transmission rate. If  
packets are being lost then the bandwidth available to the session is less than  
the transmission rate, in which case the sender congestion manager 608 informs  
the ILAM 607 that a layer should be dropped.

25 In order to select which layer should be dropped the ILAM 607 couples the  
bandwidth required by a layer with its contribution to the quality of the complete  
image, as calculated by the OQAM 605. The ILAM 607 performs an exhaustive  
search on all of the bandwidth/quality values. When the ILAM 607 has selected  
30 which layer is to be dropped from a particular scene, the timing of the drop is  
preferentially set to coincide with the transmission of that particular scene. In  
this way the drop in quality occurs with the scene change and is thus much less  
noticeable to a viewer than if the quality change had occurred during a scene.  
In the case that no packets have been lost for a preset period of time the sender  
35 congestion manager 608 will request the ILAM 607 to add in a layer to test

whether all of the available bandwidth is being employed. If no packets are lost during this experiment then the newly added layer is maintained. This process of experimentation with adding layers is continued until a significant proportion of packets are lost, in which instance the system can be confident that all of the available bandwidth is being employed. Again, the timing of the introduction of a layer is set to occur preferentially as the scene changes.

Under a given bit-rate allocation the levels of perceived quality do not change considerably within a scene, but scene cuts cause considerable changes in perceived quality, especially when the content features (spatial and motion energy) change a lot between subsequent scenes. As a consequence there will also be a significant difference in the corresponding quality scores for those successive scenes which may justify a rescheduling of the number of layers in the stream.

The invention is not limited in use to hierarchical encoding schemes. The invention is suitable for use in any encoding technique where the adaptation of transmission bit-rate to accommodate fluctuations in network capacity occurs. For instance the invention may be applied to a transcoding system where encoded data streams are transcoded from a high bit-rate to a low bit-rate or from a low bit-rate to a high bit-rate. The present invention would be suitable to reduce the impact for the viewer as the output bit-rate shifts in response to network conditions by timing the transition to occur upon a scene change in the encoded video sequence. Another example of an adaptive video streaming technique to which the invention may be applied is where multiple independent video streams of different bit-rates are transmitted. In this case the client chooses which stream to accept based on session bandwidth. The client may switch from one stream to another as bandwidth fluctuates; the present invention ensures that the switch is timed to coincide with a scene change in the encoded video stream.

Naturally, there may be times when a change of scene is such a long way away that it is advantageous to switch from one bit-rate to another other than during a change of scene. For example, consider the case where multiple independent video streams at different bit-rates are available for transmission by a media server to a client as, for example, described in co-pending European patent

application No. 00310594.7 the contents of which are hereby incorporated herein by way of reference. In such a case, the server may be capable of transmitting a first stream at a bit-rate of 500kbit/s and a second, higher quality stream at a bit-rate of 1500kbit/s. The client may initially request that the server transmit the first stream at a transmission rate of 1000kbit/s. If the network is not congested and all of the packets transmitted are successfully received by the client, the receive buffer at the client will start to fill with data at a rate of 500kbit/s, since the client will only be removing data from the buffer at a rate of 500kbit/s. After say 10 seconds of filling up the buffer at this rate, the client will have a buffer of ten seconds worth of data at which point it may decide it can attempt to receive the higher bit-rate second stream of video data from the server and thus sends an appropriate request to the server to this effect. If, however, the server is aware that the client has a receive buffer of 5 Mbytes size, it knows that it may continue sending data from the first stream at the rate of 1000kbit/s for at least another 150 seconds before the receive buffer overflows, causing problems for the client. Therefore, the server may attempt to wait for a specified period to see if a scene change occurs during this interval. If so, a switch to the second higher bit-rate signal is not made until the change of scene occurs. Of course, if there is no change of scene within the determined period, the server switches to the higher rate anyway. In this example, a period of only ten seconds is deemed appropriate as the waiting time.

Note that instead of simply waiting to see if a change of scene occurs in the specified period and switching at the end of the period if no such change of scene is detected, an alternative method would be to pre-analyse the video to be sent (clearly this only applies to pre-stored video data and not live video) and to note when changes of scene occur. In such a case, the server, upon receipt of a request from the client to switch streams, could search to see if a suitable change of scene will occur within the predetermined period and if not to switch immediately to the new bit stream.

In the present example, upon switching to the higher rate bit stream, the client may have requested a transmission rate of 1500kbit/s corresponding to the rate at which the data will be drawn from the receive buffer by the client. In such a case, the buffer size of 10 seconds should remain constant so long as all of the

transmitted packets are successfully received by the client. However, in the event of congestion on the network, a proportion of packets may fail to arrive at the client. In such a case, the server will be warned of this via the RTCP. If the congestion is sufficiently severe, the server may deduce that the buffer is in danger of emptying which would cause a break in the video displayed by the client to occur. To prevent this, the server may switch back to the lower bit rate stream. Via the notification of how many packets are being lost, the server can deduce how long it will be before the buffer is emptied. For this time, the server can wait to see if a change of scene occurs, and if so, the new stream will be switched to at that point. Note that it would also be possible for the client to simply request that the new stream be switched to upon detecting that its receive buffer is emptying at an unsustainable rate.

Note that the amount of data in the buffer is actually of less significance than the rate of change of the amount of data in the buffer. Thus it is preferably this quantity which either the server or the client measures in order to determine whether to change from one bit stream to another (or whether to add or drop a layer in the first example).

## CLAIMS

1. A method of operating a multimedia server (202), said method  
5 comprising;  
providing a stream of video data representing a video sequence to an  
output of the multimedia server (202), wherein the output of the media server  
(202) is connected to a packet based network (203),  
measuring a property of the video data in order to determine the  
10 occurrence of a scene change in the video sequence,  
detecting the available bandwidth on the network (203),  
varying the bit-rate of the stream of video data,  
wherein the method is characterised in that  
variation in the bit-rate of the video data is controlled to occur in response  
15 to variations in the capacity of the network (203) and preferentially with a scene  
change in the video sequence.
2. A method of operating a multimedia server (202) in accordance with  
claim 1 wherein upon detecting a decrease in the available bandwidth the bit-  
20 rate of the video data is decreased.
3. A method of operating a multimedia server (202) in accordance with  
claim 1 wherein the bit-rate of the video data is periodically increased in order to  
ensure that all of the available bandwidth is being used.  
25
4. A method of operating a multimedia server 202 in accordance with claims  
1 to 3 wherein said stream of video data is comprised of a plurality of  
hierarchically encoded layers.
- 30 5. A method of operating a multimedia server (202) in accordance with  
claim 4 wherein the bit-rate of the video data is varied by adding or dropping  
layers from the stream of data transferred to the output port.
6. A method of operating a multimedia server (202) in accordance with  
35 claims 4 or 5 wherein the objective quality contribution of each layer to the

overall quality of the video sequence is measured in order to determine which of the layers is to be added or dropped from the stream of data transferred to the output port.

- 5 7. A method of operating a multimedia server 202 in accordance with claims 1 to 3 wherein said stream of video data is comprised of a plurality of independently encoded flows each of which encoded at different bit-rates.
8. A method of operating a multimedia server (202) in accordance with  
10 claim 7 wherein the bit-rate of the video data is varied by switching between independently encoded flows.
9. A method of operating a multimedia server 202 in accordance with any of the preceding claims in which the source 201 of video data is stored in encoded  
15 form in a database.
10. A method of operating a multimedia server 202 in accordance with any of claims 1 to 8 in which the source 201 of video data is encoded in real-time.
- 20 11. A method of operating a multimedia server 202 in accordance with any of the preceding claims wherein, upon detecting a variation in the capacity of the network such as to render it appropriate for a change in bit rate to occur, the server waits for a predetermined time to attempt to detect a change of scene, and if such a change of scene is detected within the predetermined time, the  
25 change of bit rate is caused to occur at the time of the change of scene, but if a change of scene is not detected within the predetermined time, then the change of bit rate is caused to occur at the expiry of the predetermined time.
12. A method of operating a multimedia server 202 in accordance with any of  
30 the preceding claims wherein, upon detecting a variation in the capacity of the network such as to render it appropriate for a change in bit rate to occur, the server determines if there is going to be a change of scene within a predetermined time, and if it is determined that there will be such a change of scene within the predetermined time, the change of bit rate is caused to occur at  
35 the time of the change of scene, but if it is determined that there is not going to

be a change of scene within the predetermined time, then the change of bit rate is caused to occur substantially immediately after having made such a determination.

5 13. The method of claim 12 further including the step of, prior to providing a stream of video data to the output of the media server, processing the video data to determine the positions within the video data in which changes of scenes occur and making this information available for permitting whether a scene change will occur within a predetermined period at any point along the stream of video data.

10 14. A multimedia server (202) comprising;  
a reader (302) for reading video data representing a video sequence from a source (301),  
15 a scene change detector (604) for detecting changes of scene in the video sequence,  
a bit-rate controller (607) for controlling the rate at which the video data is transferred from the reader to an output port, wherein the output port is capable of communicating with a client (204) on a packet network (203);  
20 the media server further comprising means (608) for detecting available bandwidth between the multimedia server (202) and client (204) on the packet network,  
characterised in that  
the bit-rate controller (607) is arranged to vary the bit-rate of the video  
25 data transferred to the output port in dependence on the detected bandwidth preferentially in correlation with a scene change detected by the scene change detector (604).

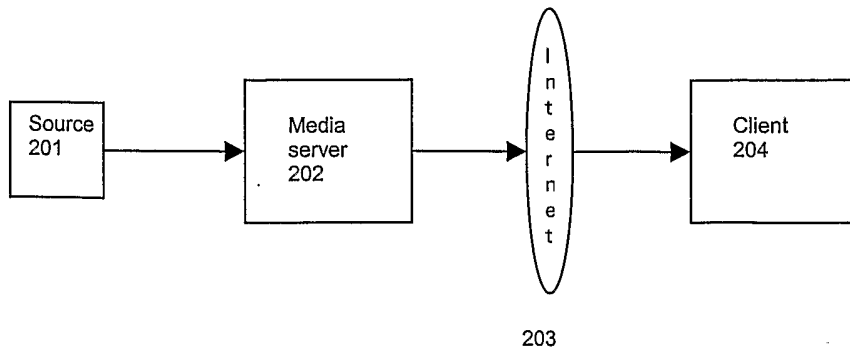

Figure 1

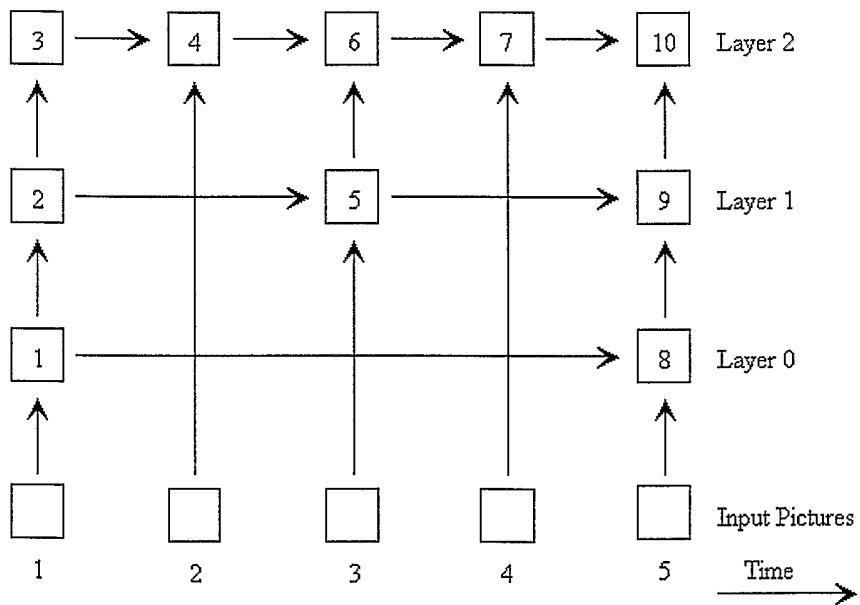

Figure 2

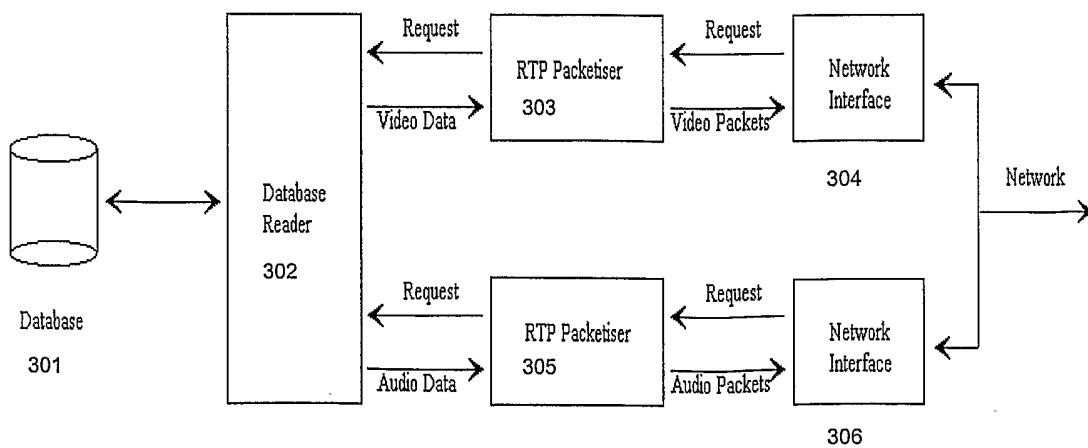

Figure 3



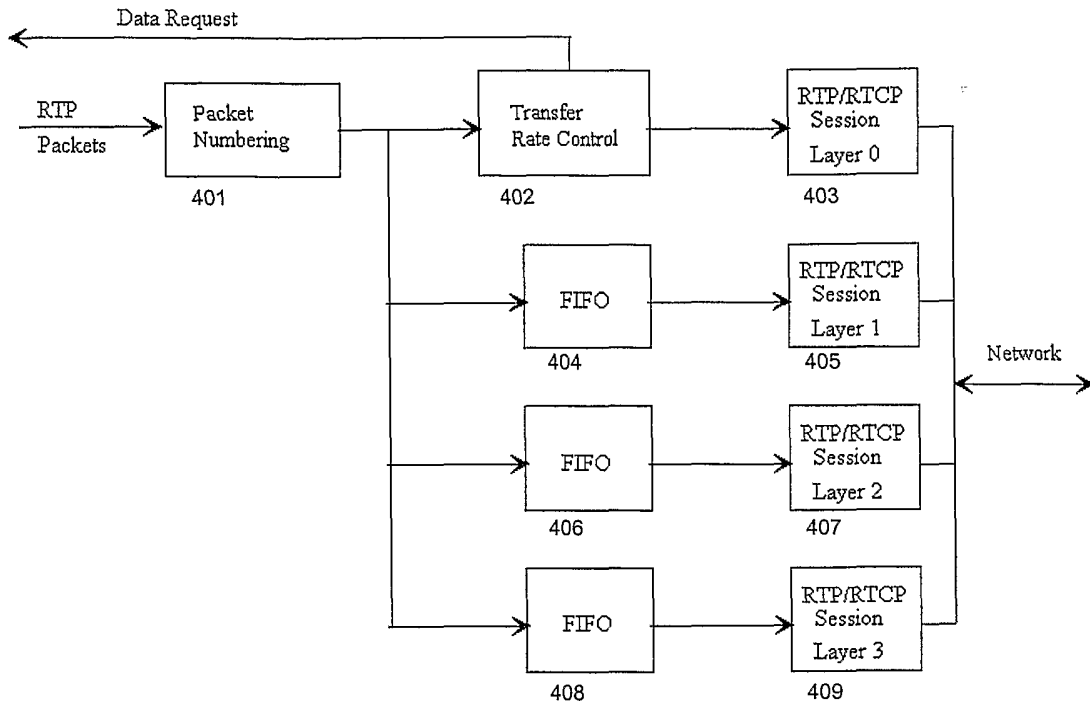

Figure 4

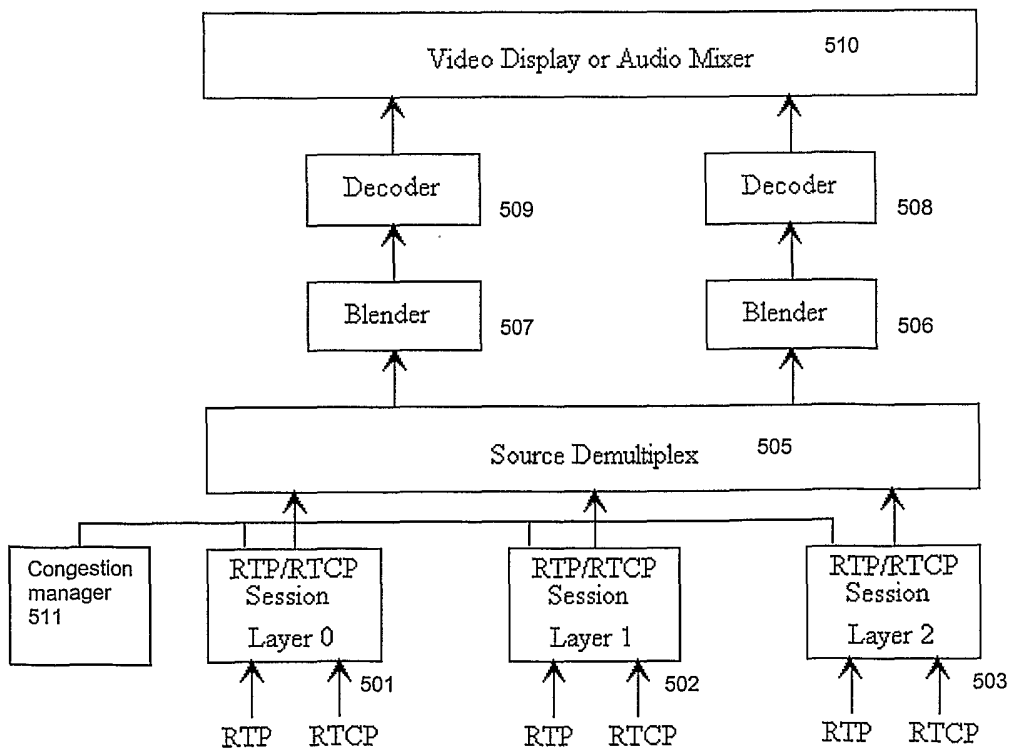

Figure 5

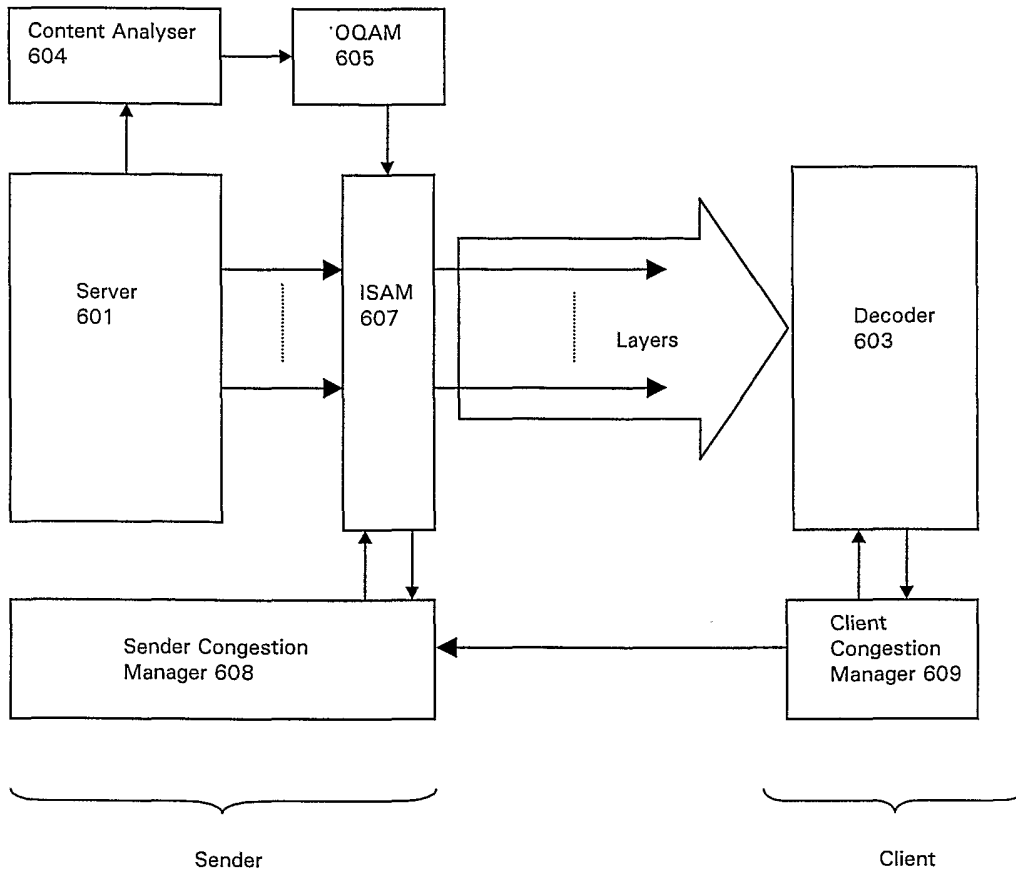

Figure 6

## INTERNATIONAL SEARCH REPORT

 International Application No  
 PCT/GB 02/03307

**A. CLASSIFICATION OF SUBJECT MATTER**  
 IPC 7 H04N5/00 H04N7/24

According to International Patent Classification (IPC) or to both national classification and IPC

**B. FIELDS SEARCHED**
 Minimum documentation searched (classification system followed by classification symbols)  
 IPC 7 H04N H04L G06F

Documentation searched other than minimum documentation to the extent that such documents are included in the fields searched

Electronic data base consulted during the international search (name of data base and, where practical, search terms used)

EPO-Internal, PAJ, IBM-TDB

**C. DOCUMENTS CONSIDERED TO BE RELEVANT**

Category °	Citation of document, with indication, where appropriate, of the relevant passages	Relevant to claim No.
X	US 6 014 694 A (AHARONI AMIR ET AL) 11 January 2000 (2000-01-11)	1-10,14
Y	abstract column 2, line 29 - line 65 column 3, line 62 -column 4, line 34 column 8, line 54 -column 9, line 35 column 10, line 34 - line 49 column 14, line 34 -column 15, line 6	11-13
X	ANONYMOUS: "Method to Deliver Scalable Video across a Distributed Computer System" IBM TECHNICAL DISCLOSURE BULLETIN, IBM CORP. NEW YORK, US, vol. 5, no. 37, 1 May 1994 (1994-05-01), pages 251-256, XP002079392 ISSN: 0018-8689	1-10,14
A	the whole document ----- -/--	11-13

 Further documents are listed in the continuation of box C.

 Patent family members are listed in annex.

° Special categories of cited documents :

- \*A\* document defining the general state of the art which is not considered to be of particular relevance
- \*E\* earlier document but published on or after the international filing date
- \*L\* document which may throw doubts on priority claim(s) or which is cited to establish the publication date of another citation or other special reason (as specified)
- \*O\* document referring to an oral disclosure, use, exhibition or other means
- \*P\* document published prior to the international filing date but later than the priority date claimed

- \*T\* later document published after the international filing date or priority date and not in conflict with the application but cited to understand the principle or theory underlying the invention
- \*X\* document of particular relevance; the claimed invention cannot be considered novel or cannot be considered to involve an inventive step when the document is taken alone
- \*Y\* document of particular relevance; the claimed invention cannot be considered to involve an inventive step when the document is combined with one or more other such documents, such combination being obvious to a person skilled in the art.
- \*&\* document member of the same patent family

Date of the actual completion of the international search

16 September 2002

Date of mailing of the international search report

23/09/2002

Name and mailing address of the ISA

 European Patent Office, P.B. 5818 Patentlaan 2  
 NL - 2280 HV Rijswijk  
 Tel. (+31-70) 340-2040, Tx. 31 651 epo nl,  
 Fax: (+31-70) 340-3016

Authorized officer

Fantini, F

## INTERNATIONAL SEARCH REPORT

International Application No  
PCT/GB 02/03307

C.(Continuation) DOCUMENTS CONSIDERED TO BE RELEVANT		
Category °	Citation of document, with indication, where appropriate, of the relevant passages	Relevant to claim No.
Y	US 6 038 000 A (HURST JR ROBERT NORMAN) 14 March 2000 (2000-03-14)	11-13
A	column 2, line 52 -column 3, line 22 column 4, line 20 - line 49 column 6, line 9 - line 45 column 7, line 1 - line 24 column 13, line 46 -column 14, line 18 column 20, line 13 - line 30 -----	1,14
A	EP 1 079 631 A (SONY UK LTD) 28 February 2001 (2001-02-28) page 3, line 1 - line 4 -----	1-14
A	US 5 990 945 A (DENTENEER THEODORUS J J ET AL) 23 November 1999 (1999-11-23) abstract column 3, line 13 - line 35 column 4, line 42 - line 44 column 5, line 37 - line 39 -----	11-13

## INTERNATIONAL SEARCH REPORT

Information on patent family members

International Application No

PCT/GB 02/03307

Patent document cited in search report		Publication date	Patent family member(s)	Publication date
US 6014694	A	11-01-2000	AU 7928998 A	19-01-1999
			EP 0992160 A1	12-04-2000
			WO 9900984 A1	07-01-1999
			JP 2002511216 T	09-04-2002
US 6038000	A	14-03-2000	US 6137834 A	24-10-2000
			EP 0954924 A1	10-11-1999
			JP 2001509354 T	10-07-2001
			WO 9832281 A1	23-07-1998
			EP 0901718 A1	17-03-1999
			JP 2002503402 T	29-01-2002
			KR 2000016034 A	25-03-2000
			WO 9745965 A1	04-12-1997
EP 1079631	A	28-02-2001	GB 2353653 A	28-02-2001
			EP 1079631 A1	28-02-2001
			JP 2001119305 A	27-04-2001
US 5990945	A	23-11-1999	CN 1199532 A	18-11-1998
			EP 0860087 A1	26-08-1998
			WO 9809442 A1	05-03-1998
			JP 11514825 T	14-12-1999