

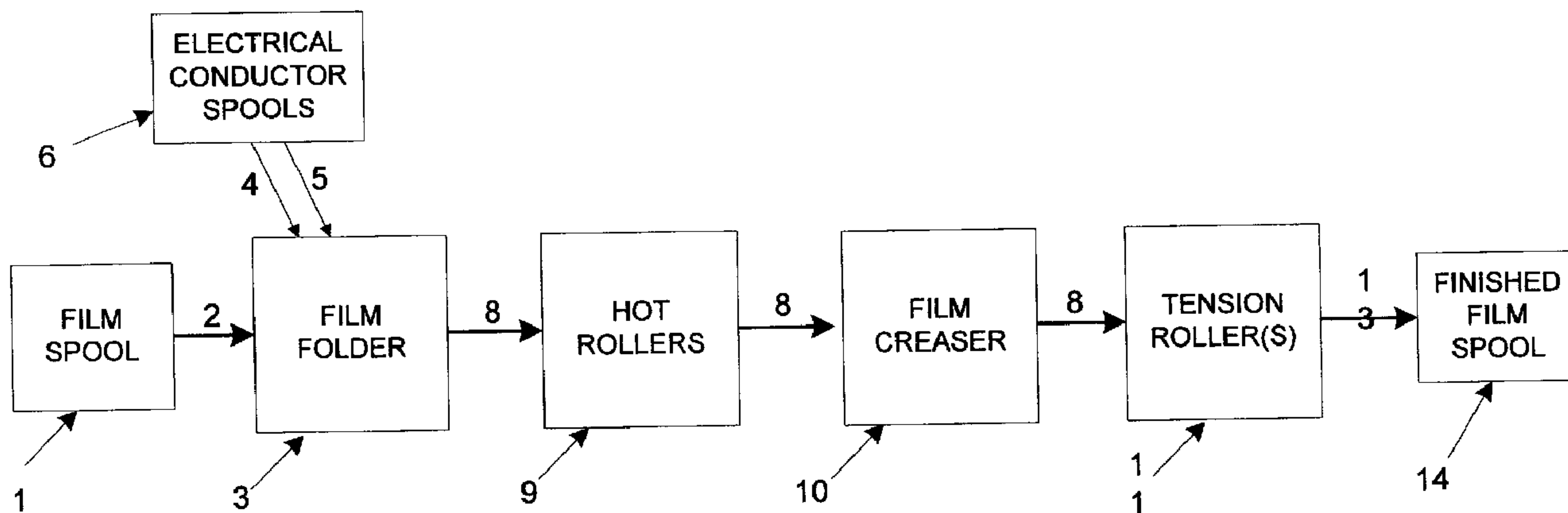

(22) Date de dépôt/Filing Date: 2003/09/11  
 (41) Mise à la disp. pub./Open to Public Insp.: 2004/03/25  
 (62) Demande originale/Original Application: 2 498 201  
 (30) Priorités/Priorities: 2002/09/11 (NZ521364);  
 2002/10/31 (NZ522310)

(51) Cl.Int./Int.Cl. *B29C 53/36* (2006.01),  
*F16L 11/112* (2006.01), *F16L 11/16* (2006.01),  
*F16L 11/24* (2006.01), *A61M 39/08* (2006.01),  
*A61M 16/08* (2006.01)  
 (71) Demandeur/Applicant:  
 FISHER & PAYKEL HEALTHCARE LIMITED, NZ  
 (72) Inventeurs/Inventors:  
 SMITH, DANIEL JOHN, NZ;  
 GRAY, NATHAN LEE, NZ;  
 GALLAGHER, LUKE JEREMY, NZ;  
 HATCHER, KIERAN JAMES, NZ;  
 LAURENT, KRISTOPHER POH MING, NZ  
 (74) Agent: RICHES, MCKENZIE & HERBERT LLP

(54) Titre : CONDUITS ET PROCEDE DE FABRICATION  
 (54) Title: CONDUITS AND METHOD OF FORMING



(57) **Abrégé/Abstract:**

A method of continuously forming heated conduit includes performing a tape for winding onto a spiral pipeline former. At least one conductor is positioned adjacent to the centreline of and parallel with a thin polymer ribbon. The ribbon is folded in half to encapsulate the conductors. The folded ribbon is thermally welded to itself. The folded, welded, ribbon is passed through a creaser, which forms a crease midway across the folded ribbon. The creased pre-formed ribbon is formed into a conduit in a continuous process on a spiral pipeline former.

**ABSTRACT:**

A method of continuously forming heated conduit includes performing a tape for winding onto a spiral pipeline former. At least one conductor is positioned adjacent to the centreline of and parallel with a thin polymer ribbon. The ribbon is folded in half to encapsulate the conductors. The folded ribbon is thermally welded to itself. The folded, welded, ribbon is passed through a creaser, which forms a crease midway across the folded ribbon. The creased pre-formed ribbon is formed into a conduit in a continuous process on a spiral pipeline former.

## **“CONDUITS AND METHOD OF FORMING”**

### **Related Application**

This application is a divisional of Canadian Patent Application Serial No. 2,498,201, filed September 11, 2003 as the Canadian national phase application corresponding to International Application No. PCT/NZ2003/000204, filed September 11, 2003.

### **BACKGROUND TO THE INVENTION**

#### **Field of the Invention**

The present invention relates to components for breathing circuits and in particular to conduits for use in the limbs of breathing circuits. The invention also relates to methods of manufacturing such conduits.

#### **Summary of the Prior Art**

In assisted breathing, particularly in medical applications, gases are supplied and returned through conduits. Such conduits are ideally light and flexible to ensure the greatest level of comfort for the patient. In the prior art, thin walled conduits are known which include helical or annular reinforcing ribs which act to give the conduit better resistance to crushing and pinching, while still allowing the conduit to be light and flexible. An example of one such conduit is shown in Figure 1.

It is advantageous to manufacture this type of conduit as a continuous process. In the prior art this is achieved by spiral winding of a thin polymer tape onto a former such that the edges of adjacent layers overlap a small amount. A bead of molten polymer is then applied over the top of the overlapping edges welding them together and simultaneously forming the helical reinforcing ribs. To form a heated conduit, one or more heater wires are positioned on the polymer tape or film as the tape is drawn onto the former. The wires must be accurately positioned adjacent the free edge of the tape, to be covered by a subsequent turn and then by the molten bead. Continuous accurate positioning can be difficult to achieve, and if it is lost the wire can be exposed to either the inside or outside of the tube instead of being encapsulated in the conduit wall.

### **SUMMARY OF THE INVENTION**

It is an object of the present invention to provide a conduit, with particular application to the limbs of a breathing circuit, which will at least go some way towards improving on the above or which will at least provide the public and the medical profession with a useful choice, and/or to provide a method of manufacturing a conduit

which will at least go some way towards providing the public and manufacturers with a useful choice.

In a first aspect the invention may broadly be said to consist in a method of forming a film comprising:

5 providing a thin polymer ribbon,  
positioning at least one conductor adjacent to and substantially parallel with said ribbon,

folding said ribbon substantially in half parallel with said ribbon such that said at least one conductor is adjacent to, and encapsulated in said fold, and

10 thermally welding said folded ribbon to itself to permanently encapsulate said at least one conductor, thereby forming a double layered film with integral conductor.

Preferably said at least one conductor is a pair of conductors, and said conductors are positioned parallel and closely spaced and said ribbon is folded adjacent one said conductor; such that a first of said pair of conductors is adjacent to and encapsulated in  
15 said fold, and

a second of said pair of conductors is spaced from said first conductor and encapsulated in said fold.

Preferably said thermal welding comprises passing said folded ribbon between a pair of heated rollers,

20 said rollers applying pressure to squeeze said folded ribbon together.

Preferably at least one of said rollers includes a groove for at least partially receiving each of said at least one conductor and the layer of ribbon over it.

Preferably said method further comprises forming a crease substantially midway along said folded ribbon, said crease being substantially parallel with said ribbon;

25 forming said crease while said ribbon is softened following said thermal welding occurring.

Preferably said crease is formed by passing said folded film through at least one set of crease rollers,

said rollers in a creasing region shaped according to the profile of said crease.

30 In a further aspect the invention may broadly be said to consist in a method of forming a film comprising:

providing a thin polymer ribbon,  
heating said ribbon to soften said ribbon,  
forming a crease approximately midway across said ribbon, said crease being  
substantially parallel with said ribbon, and

5 winding said creased ribbon onto a spool

Preferably said crease is formed by passing said film through at least one set of  
crease rollers,

said crease rollers in a creasing region shaped according to the profile of said  
crease.

10 In a further aspect the invention may broadly be said to consist in a method of  
continuously forming a conduit comprising:

providing a thin polymer ribbon,

positioning at least one conductor adjacent to and substantially parallel with  
said ribbon,

15 folding said ribbon substantially in half parallel with said ribbon such that said  
at least one conductor is adjacent to, and encapsulated in said fold, and

thermally welding said folded ribbon to permanently encapsulate said at least  
one conductor,

20 supplying said folded ribbon having "leading" and "trailing" lateral edges,  
spirally around a former rotating and advancing said conduit, with the leading edge of  
each turn of ribbon overlapping the trailing edge of a previous turn of ribbon on the  
former and the trailing edge of each turn underlapping the leading edge of a  
succeeding turn, and

25 applying a bead of molten plastic material to said lapping edges of adjacent  
turns of ribbon, such that said bead welds said adjacent edges.

Preferably said at least one conductor is a pair of conductors, and said  
conductors are positioned parallel and closely spaced and said ribbon is folded  
adjacent one said conductor, such that a first of said pair of conductors is adjacent to  
and encapsulated in said fold, and

30 a second of said pair of conductors is spaced from said first conductor and  
encapsulated in said fold.

Preferably said thermal welding includes passing said folded ribbon between a  
pair of heated rollers,

-4-

said rollers applying pressure to squeeze said folded ribbon together.

Preferably at least one of said rollers includes a groove for at least partially receiving each of said at least one conductor and the layer of ribbon over it.

Preferably said method further comprises forming a crease substantially  
5 midway along said folded ribbon, said crease being substantially parallel with said ribbon;

forming said crease while said ribbon is softened following said thermal welding occurring.

Preferably said crease is formed by passing said folded film through at least one  
10 set of crease rollers,

said crease rollers in a creasing region shaped according to the profile of said crease.

In a further aspect the invention may broadly be said to consist in a method of continuously forming conduit comprising:

15 providing a thin polymer ribbon,

heating said ribbon to soften said ribbon,

forming a crease approximately midway across said ribbon, said crease being substantially parallel with said ribbon,

supplying said folded ribbon having "leading" and trailing" lateral edges,  
20 spirally around a former rotating and advancing said conduit, with the leading edge of each turn of ribbon overlapping the trailing edge of a previous turn of ribbon on the former and the trailing edge of each turn underlapping the leading edge of a succeeding turn, and

applying a bead of molten plastic material to said lapping edges of adjacent  
25 turns of ribbon, such that said bead welds said adjacent edges.

Preferably said crease is formed by passing said folded film through at least one set of crease rollers,

said crease rollers in a creasing region shaped according to the profile of said crease.

30 In a further aspect the invention may broadly be said to consist in an apparatus for forming a film comprising:

a means for supplying a thin polymer ribbon,

at least one spool for supplying at least one thin conductor, at a first position adjacent to and substantially parallel with said ribbon,

a folding means to fold said ribbon substantially in half such that said at least one conductor is adjacent to and encapsulated by said folded ribbon,

5 a thermal welding means adapted to weld said folded film to itself and permanently encapsulate said at least one conductor, thereby forming a double layered film with integral conductor.

Preferably said thermal welding means includes a pair of heated rollers, said rollers applying pressure to squeeze said folded ribbon together.

10 Preferably at least one of said rollers includes a groove for at least partially receiving each of said at least one conductor and the layer of ribbon over it.

In a further aspect the invention may broadly be said to consist in an apparatus for forming a film comprising:

a means for supplying a thin polymer ribbon,

15 a heating means for heating said thin polymer ribbon,

a creasing means for forming a crease in said ribbon after being heated by said heating means, approximately midway across said ribbon, said crease being substantially parallel with said ribbon, and

a spool for receiving said creased ribbon.

20 Preferably said apparatus further comprises:

a creasing means for forming a crease in said ribbon approximately midway across said ribbon, said crease being substantially parallel with said ribbon.

In a further aspect the invention may broadly be said to consist in an apparatus for continuously forming conduit comprising:

25 a means for supplying a thin polymer ribbon,

at least one spool for supplying at least one thin conductor, at a first position adjacent to and substantially parallel with said ribbon,

a folding means to fold said ribbon substantially in half such that said at least one conductor is adjacent to and encapsulated by said folded ribbon,

30 a thermal welding means adapted to weld said folded film to itself and permanently encapsulate said at least one conductor, thereby forming a double layered film with integral conductor,

a means for delivering said folded ribbon having "leading" and trailing" lateral edges, spirally around a former rotating and advancing said conduit, with the leading edge of each turn of ribbon overlapping the trailing edge of a previous turn of ribbon

on the former and the trailing edge of each turn underlapping the leading edge of a succeeding turn, and

a means for applying a bead of molten plastic material to said lapping edges of adjacent turns of ribbon, such that said bead welds said adjacent edges.

Preferably said apparatus further includes, a creasing means for forming a crease in said folded ribbon approximately midway across said ribbon,

said crease being substantially parallel with said ribbon, and

said creasing means positioned to crease said ribbon before being delivered around said former.

In a further aspect the invention may broadly be said to consist in an apparatus for continuously forming conduit comprising:

a means for supplying a thin polymer ribbon,

a heating means for heating said polymer ribbon,

a creasing means for forming a crease in said ribbon after being heated by said heating means, approximately midway across said ribbon, said crease being substantially parallel with said ribbon,

a means for delivering said creased ribbon having "leading" and trailing" lateral edges, spirally around a former, with the leading edge of each turn of ribbon overlapping the trailing edge of a previous turn of ribbon on the former and the trailing edge of each turn underlapping the leading edge of a succeeding turn, to form said conduit

said former adapted to rotate and advance said conduit,

a means for applying a bead of molten plastic material to said lapping edges of adjacent turns of ribbon, such that said bead welds said adjacent edges.

In a further aspect the invention may broadly be said to consist in a conduit formed by a method according to any one of the above paragraphs.

In a further aspect the invention may broadly be said to consist in a film formed by a method according to any one of the above paragraphs.

To those skilled in the art to which the invention relates, many changes in construction and widely differing embodiments and applications of the invention will suggest themselves without departing from the scope of the invention as defined in the appended claims. The disclosures and the descriptions herein are purely illustrative and are not intended to be in any sense limiting.

**BRIEF DESCRIPTION OF THE DRAWINGS**

**Figure 1** is a cross sectional side elevation of a conduit wall according to an embodiment of the prior art.

5 **Figure 2** is a flow diagram of the pre-forming of a narrow plastic film to be used in the manufacture of a conduit of an embodiment of the present invention.

**Figure 3** is a cross sectional view of pre-forming a film, including a pair of heater wires, for use in forming the conduit of an embodiment of the present invention.

10 **Figure 4** is a cross sectional view of a pair of heater wires embedded in the film.

**Figure 5** is a cross sectional view of a folded film with a crease formed in it.

**Figure 6** is a cross section view of a folded film with a crease formed in it accordingly to a further embodiment.

15 **Figure 7** is a cross sectional view of a conduit wall including a pair of heater wires, formed from the pre-formed film shown in Figure 4.

**Figure 8** is a side elevation of a conduit according to an embodiment of the present invention having an outer reinforcing bead.

**Figure 9** is a plan view of a conduit forming device for forming a conduit according to an embodiment of the present invention.

20 **Figure 10** is a flow diagram of the steps in the method of manufacturing a conduit according to an embodiment of the present invention.

**Figure 11** is a diagrammatic side view of apparatus used to form the pre-formed film of the present invention.

25 **Figure 12** is a diagrammatic end view of apparatus used to form conduit according to an embodiment of the present invention.

**Figure 13** is a cross sectional view of the reinforcing bead extruded onto the conduit on the mandrel.

**Figure 14** is a front view of the film creaser showing the crease rollers.

**Figure 15** is a view of the pre-formed film passing through the hot rollers.

30 **Figure 16** is a flow diagram showing steps in the method of manufacturing conduit according to a further embodiment of the present invention.

**DETAILED DESCRIPTION OF THE PRIOR ART**

The present invention relates to breathing conduits in general and in particular to improved methods of forming thin film spiral wound conduits. Consequently the present invention finds application in breathing conduits fabricated from a variety of materials which may include breathable and/or non-breathable materials (breathable materials being capable of transmitting water vapour).

Continuous Positive Airway Pressure (CPAP) systems or positive pressure ventilation systems that provide patients suffering from obstructive sleep apnoea (OSA) with positive pressure gases often use conduits similar to the prior art described. Often in these applications and in other medical applications, such as with assisted breathing, gases having high levels of relative humidity are supplied to patients and sometimes returned through conduits of a relatively restricted size. The aim of the present invention is to provide an alternative conduit that will withstand the stresses of high use, that is, being flexible yet not prone to breakage under axial stretching or movement.

The preferred conduits of the present invention are formed from a non-breathable material, such as a polymer plastic block formed into a homogeneous flat film. Examples of such polymer materials, are sold under the brands EXACT and EVOLUE.

In alternative forms of the conduit of the present invention, a conduit may be formed from a breathable material, such as a hydrophilic polyester block copolymer formed into a homogeneous flat film.

The following embodiments will be described with particular reference to an example non-breathable thin film wall construction from materials such as EVOLUE. It will be appreciated however, that in the following described embodiments the material used to form the conduit walls may be either breathable or non-breathable and may also include combinations of both breathable and non-breathable materials. It will be also appreciated for the following described embodiments that the film that is manipulated during the pre-forming stage of the method of the present invention, may be supplied initially either as a pre-formed film wound on to a spool or may alternatively be supplied directly from an extruder. It will also be appreciated by those skilled in the art that the materials supplied to a former used in the manufacture of the

conduit may require guides and/or rollers in order to position the film accurately and provide the necessary tension.

It is preferred that the conduit wall be manufactured to have a relatively low wall thickness, so much so that the conduit wall membrane may be insufficiently  
5 sturdy to be self supporting. Spiral or helical reinforcing members are therefore provided as part of the tubular wall membrane to provide support. The helical or spiral supporting members are formed from polymer plastic materials and may be of the same material used in the wall of the conduit or any other compatible plastics material.

Referring to Figure 1, the lay-up arrangement of a flexible breathing conduit  
10 known in the art is shown.

#### **Pre-forming of Film**

The first step in the manufacture of the conduit of the present invention is the forming of a folded plastic film. The film may be formed with or without at least one  
15 integral electrical conductor. In other forms of the pre-formed film, the film may be formed with other material in place of the electrical conductor or conductors, such as a foam strip, a strip of conductive film or other conductive or insulative materials or a combination of both. The following describes by way of example, only one such form of the folded plastic film, i.e with at least one integrally formed conductor.

Referring to Figure 2, a method of forming a plastic film including two parallel  
20 conductors is illustrated. Firstly, a plastic film 2, such as EVOLUE film, is supplied on a spool 1. Two electrical conductive wires 4, 5 are supplied on two spools 6. The film 2 and wires 4, 5 are simultaneously drawn from their respective spools 1, 6 and fed into the film folder 3. The film folder 3 preferably folds the film 2 in half with one  
25 of the two wires 5, running down the centre fold (X in Figures 3 to 6) in the film 2. Figure 3 shows the film 2 and two wires 4, 5 prior to being fed into the film folder. Wires 4, 5 are accurately positioned via guides adjacent the fold position X and spaced apart on the surface of film 2. The arrow in Figure 3, indicated as 7, shows one side of the film (the first side 15), which is folded over the second side 16 of the film 2,  
30 thereby encapsulating the wires 4, 5. The resulting double layered folded film 8 including two substantially parallel encapsulated conductors is shown in Figure 4. The

first lateral half 15, becomes the top layer of the film 8 and the second lateral half 16 becomes the bottom layer of the film 8.

With reference to Figures 2, 4 and 15, the resulting folded film 8 with encapsulated wires 4, 5 is then drawn between two hot rollers 9. The hot rollers have a surface temperature sufficient to soften the film and bond adjacent layers under pressure, for example approximately 90°C and 120°C. Depending on the speed at which the film travels through the hot rollers 9, it may be necessary to have several stages of hot rollers to ensure that adequate welding occurs. Further, it may also be desirable to include secondary welding processes such as ultrasonic welding, or hot air welding. The hot rollers may be formed of any suitable material, for example aluminium. It has been found that an outer deformable surface layer 49, on at least one of the hot rollers, is useful to grip the film passing through the rollers and allow at least one of the roller surfaces to deform a little around the encapsulated wires. An example of a suitable material for this outer layer on the roller is silicon rubber. The hot rollers 9 are driven by a motor (not shown) to pull the film 2 and wires 4, 5 off their respective spools 1, 6 and draw the film 2 through the film folder 3. Heat from the rollers 9 softens the film (as the rollers temperatures are close to the film's melting temperature) while pressure exerted by the rollers as the folded film passed between them, presses the layers 15 and 16 of the folded film together causing the folded sides to fuse together, permanently encapsulating the wires therein.

In order to ensure that the encapsulated wires 4, 5 are maintained in their desired positions during the fusing process, at least one of the hot rollers includes a pair of grooves 48, adapted to receive wires 4. The position and dimensions of the grooves are such that they prevent the pressure exerted by the rollers on the film from flattening the film in the region of the conductive wires 4, 5 thus reducing undesired thinning of the polymer film around the encapsulated wires. These grooves 48 provide guidance for the wires 4, 5 ensuring they are positioned correctly with respect to the fold, and spaced the desired distance apart, for example, approximately 1 millimetre. It is preferred in the manufacture of folded film 8, that the film folder 3 is positioned so that the fold X runs on one of the grooves of the hot rollers 9, thereby positioning the first wire 5 into the fold X and the second wire 4, 1 millimetre away from the fold X. The film folder 3, is configured so that uneven film overlap is prevented. Such

-12-

positioning of the film folder 3 is important to produce good quality pre-formed and folded film. In other, embodiments of the pre-formed and folded film the wires may be located at a distance from the fold or at different distances from one another.

The folded film 8 is then drawn from the hot rollers 9 and preferably passed  
5 through a film creaser 10 as shown in Figure 14. The film creaser 10 consists of a roller 33 having a substantially v-shaped edge which runs in a correspondingly shaped groove in roller 34. The film creaser 10, creates a crease 12 in the folded film 8, as shown in Figure 5. The crease 12 is formed in the folded film 8 subsequent to the hot rollers 9, while the film is still soft. The crease 12 may be formed approximately  
10 midway along the width of the folded film, in order to position the crease approximately midway between the turns of reinforcing bead in the finished conduit. The folded and creased film 13 is then uniformly drawn onto a finished film spool 14. The purpose of the crease 12 is to bias the conduit wall outward between the helical reinforcing bead. In use, when the conduit is contracted or bent, it is desirable to have  
15 the conduit wall portions between the bead, bulge outwards to reduce interference with the gasses flow within the conduit. The crease 12 encourages the conduit wall portions between the reinforcing bead to take up a regular folded position between the reinforcing bead 19 when the conduit is contracted or bent.

Reference is now made to Figures 2 and 11. As the folded film is still soft  
20 when it comes out of the film creaser 10, the tension of the folded film 8 has to be controlled accurately so that the folded film 8 is not overstretched making the film thinner or narrower. Therefore, film 8 may be drawn through at least one tension roller 11, although more than one roller may be used. As shown in Figure 11, two tension rollers 40, 41 are provided attached to an arm 42, and controlled by a position  
25 sensor 43. If the rollers 40, 41 are not in a position to provide the correct tension in the film 8, the rollers 40, 41 are adjusted until the correct film tension is applied. The rollers 40, 41 are attached to an arm 42 that rotates about a pivot point 44. When the tension of the film 8 increases and more force is placed on the rollers 40, 41 and arm 42, the arm 42 moves upwards out of a neutral position, (as shown on Figure 11). The  
30 position sensor 43 located near the arm 42 detects the movement of the arm and causes the motor drawing the film through the rollers and onto the finished film spool 14 to decrease its speed, consequently reducing the pull on the film 8 through the tension

rollers 40, 41. Conversely, if the position sensor 43 detects the movement of the arm 42 downwards out of the neutral position due to a reduction in the film tension, the sensor 43 causes the motor to increase its speed causing the film 8 to be drawn more quickly through the rollers 40, 41.

5

It has been found that varying the shape of crease 12 (as shown in Figure 5) maybe advantageous for influencing the conduit wall to deflect in a desirable manner. For example it has been found that a wider more rounded arcuate crease (such as shown in Figure 6) may be more effective in ensuring that the conduit wall behaves as  
10 desired when the conduit is constricted axially or bent. It will be appreciated by those in the art that the profile of crease rollers 33 and corresponding roller 34 (as shown in Figure 14) will influence the shape of crease 12. Further it will also be appreciated that crease roller 33 may be wider than shown and also include portions for guiding the outer regions of folded film 8 to reduce the tendency of the film to curl in an  
15 undesirable manner during creasing. It has also been found that forming crease 12 after the film is folded and fused, but before the pre-formed and folded film is wound onto a storage spool 14, may lead to a certain amount of flattening out of crease 12 while on the storage spool. It has been found to be advantageous to delay the crease forming process until immediately before forming the conduit. In this alternative  
20 embodiment of the method, the pre-formed tape 8 is folded (with or without encapsulated conductors) and fused, before being wound onto a storage spool, and after sufficient cooling. With reference to Figure 16, before the conduit forming process described below is commenced, the folded film 8 (but not creased), is heated and fed through the film creasing apparatus 10 described above. In a similar manner  
25 to described above, the film may be passed through a series of tension rollers and/or pinch rollers in order to control the tape forming and winding process. After the film has passed through the film creaser 10, the film is allowed to cool and harden a little before being fed onto the forming mandrel 24 and the conduit 17 is formed. In other embodiments of the pre-formed film of the present invention, a film may be formed  
30 that does not have the conductive wires encapsulated within it. This form of the film could be used in conduits not requiring heating elements.

It will be appreciated that the method of forming a conduit described herein discloses both a pre-formed and folded tape encapsulating one or more elements such as conductors or insulators, as well as a method of creasing a pre-formed tape at sometime before supplying it to a forming mandrel. However, it will also be appreciated that the pre-formed film method and the pre-creasing method may both be applied to a conduit forming method or maybe applied individually.

### **Conduit Forming**

A conduit formed using a pre-formed film such as those discussed above will now be described in more detail. It will be appreciated that manufacture of heated conduits (including at least one conductor) is achieved by using a pre-formed film as described above including at least one imbedded conductor. Similarly, the manufacture of non heated conduits is achieved by employing a pre-formed film without any encapsulated conductors.

The following description does not distinguish between a pre-formed film with or without encapsulated material. Therefore, when "film" or "pre-formed film" is referred to below it will be appreciated that the film may or may not include embedded conductors or insulative materials or both.

Figure 8 illustrates a conduit 17 formed from a film as described above and using the conduit forming method as described below. It will be appreciated that the figures (for example Figure 7) are illustrative and may show gaps or spaces between layers of film and reinforcing bead that are not actually present in the finished product but are shown in the figures to distinguish layers. The conduit may be used as a transport path or passageway for supplying gases to a patient and has a thin film flexible wall. The film, such as the pre-formed film described above, is arranged in a spiral or helix such that the edge portions of adjacent layers overlap and form the wall 18 of the conduit or tube 17. A helical reinforcing bead 19 of polymer material is extruded over the overlapping portions of adjacent winds of film to bond the overlapping portions of film to form a continuous conduit or tube 17.

Figure 7 illustrates a similar conduit to that of Figure 8, but having integral conductors formed into the conduit wall. Figure 7 shows a cross section of a folded film including two encapsulated conductive wires 4,5. The bead 19 is extruded onto

the overlapping portions of adjacent layers 31, 32 (having the encapsulated conductive wires 4, 5). The molten bead 19 bonds the two layers together.

An example of the forming apparatus suitable for manufacturing the conduits of Figure 7 or Figure 8 is shown in Figures 9 and 12. Figure 10 illustrates the steps in the  
5 conduit forming process of the present invention. The spool 14 of pre-formed film as described above is mounted onto a frame (not shown) of the conduit forming apparatus. The film (which may include wires 4,5) is drawn from the spool 14 through various tension pads and rollers 21, then through pinch rollers 22. Next the film passes through at least one tension roller 23 and is fed onto a mandrel or former 24.

10 With reference to Figure 9, the former, preferably of a known type, includes a plurality of rotating rods or cables arranged around a central support rod. The rods or cables extend from and are rotated by a gearbox within a machine stock 26. At least in the conduit forming region the rotating rods follow a helical path. The pitch angle of the rods relative to the support rod controls the pitch angle of the conduit being  
15 formed. An example of such a former is a spiral pipeline mandrel available from OLMAS SRL of Italy.

The conduit being formed on the former is rotated and advanced in the direction of arrow 27 by the movement of the rotating cables. The advance speed of the former is selected relative to the rotational speed of the cables and is dependent on the pitch of  
20 the helical laying of the film on to the former, such that adjacent turns of the film narrowly overlap. The spool 14 of pre-formed film 8 as described above is eventually fed (after being fed through tension rollers and the like) onto the former (mandrel 24) in a helical fashion by action of the former. The pitch of the helical disposition of film 8 is slightly less than the width of film 8 and results in an overlap of approximately 2  
25 millimetres. The helical deposition of film 8 forms the wall 18 of the conduit shown in Figure 8. An extruder 28 extrudes the bead 19 of polymer material onto the overlap of the film winds. The rotating mandrel 24 draws the molten bead 19 over the overlapping portions of adjacent winds of film 8, the bead is sufficiently heated to weld to the layers of film 8. In one preferred embodiment of the present invention the  
30 bead 19 is extruded at approximately 250°C providing enough heat to thermally bond the layers of film together. The conduit formed according to this method has an approximate internal diameter of 19 millimetres. It will be appreciated by those

-16-

skilled in the art that alternative or secondary welding processes may also be employed, for example ultrasonic welding, or hot air welding.

It will be appreciated however that the method of forming is also suitable for both larger and smaller conduits. If the conduit is a heated type having encapsulated  
5 conductive wires (see Figure 7), the extruder 28 is positioned so that the bead 19 is drawn on to the correct position to completely bond the overlapping film together and to encapsulate the wires. In both heated and non-heated conduits, the bead 19 is shaped to assist in the forming of the conduit.

With reference to Figures 7 and 13, the bead 19 is concave nearer the middle of  
10 its underside, and edges 38, 39 are angled out to the periphery of the bead 19. The concave shaped underside 37 helps to provide guidance for the laying of the bead 19. The bead tends to follow the raised portions of film created by the encapsulated wires. The straight sides 38, 39 of the underside of the bead also help to keep the film 20 flat and become substantially horizontal during the forming process. The bead 19 may be  
15 extruded with indented sides 35, 36 toward the base of the bead. After extrusion, the bead 19 tends to change shape or "swell". Indented sides 35 and 36 may be provided in order to better control the final shape of reinforcing bead 19 in the finish conduit.

When the conduit thus formed is contracted longitudinally, the crease 12 formed in the film, as shown and described in relation to Figure 5 and 6, tends to cause  
20 a folding in the conduit outwards between the reinforcing bead 19 and moves the film out of the gases path through the conduit. The bead width and height are chosen to give an adequate crush strength and to allow enough space for the film to fold upwards between the bead, while retaining its general shape and proportions.

Referring back to Figures 10 and 12, the frame of the conduit forming apparatus  
25 of the present invention has many degrees of freedom to allow adjustment of the angle that the film is fed onto the mandrel 24. The frame includes a set of set of pinch rollers 22 mounted thereon, which pull the film from it's spool 14, through at least one tensioning pad and around at least one roller 21, which are also mounted on the frame of the conduit forming apparatus. The film 20 is then fed around at least one tension  
30 roller 23 and then onto the mandrel 24.

A difference in speed between the pinch rollers 22 and the cables on the mandrel 24 may create tension in the film. The film tension is important to maintain

the stability of the film on the mandrel 24 and also to allow the film wall to fold upwards between the reinforcing bead 19, when the conduit is bent or contracted.

The tension roller 23 is controlled by a sensor 45 and arm 46, in a similar manner as described previously for the pre-formed film method. If the tension in the film 20 increases, roller 23 (attached to the arm 46) and arm 46, pivoting about a pivot point 47, move upwards in the direction of arrow A. The position sensor 46 senses the change in position of the arm 46 and thus roller 23 and the motor driving the pinch rollers 22 increase the speed at which the film is drawn from the spool 14 and the tension in the film reduces causing the roller 23 and arm 46 to move back to the central position as shown in Figure 12. Conversely, if the tension of the film decreases the arm 46 and roller 23 move downwards in the direction of arrow B. The position sensor 45 senses this change in position and causes the motor driving the pinch rollers 22 to decrease the speed at which the film is drawn from the spool 14. The sensor 45, pivotable arm 46 and roller 23, ensure that a constant tension of the film is maintained so that the film 20 being wound onto the mandrel 24 has a constant overlap.

The mandrel 24, may include air or water cooling or both, to cool the conduit as it is formed on the mandrel 24 to ensure that the bead 19 does not melt through both the overlapping layers of film. Further cooling, external to the conduit, may also be provided. Internal air cooling may be provided by stainless steel needle like tubing on the mandrel, which spray several fine jets of air onto the inside of the tube. External air-cooling may be provided by a series of air jets that spray a blade of air onto the outside of the tubing.

The mandrel 24 will now be described in more detail. Mandrel 24 includes six stainless steel cables, all of which are rotated at the same speed. The cables are located in the mandrel 24 within undercut grooves, machined into the stainless steel mandrel in a helical configuration. The mandrel 24, preferably made of stainless steel, has scallops machined into it between the cable grooves to provide a clearance so that the film rests on the cables, rather than the mandrel 24. A groove is also machined into the centre of these scallops to provide a space for the air cooling tubing. The mandrel may also be water cooled, and include monitoring of the water flow rate, to ensure that there is sufficient cooling.

-18-

The cables provide the drive to pull the film onto the mandrel 24 as described above. The helical angle of these cables is important to create the correct amount of overlap of the film. With the angle of the cables set at 6.6 degrees to the horizontal, the film is drawn onto the mandrel 24 and is wrapped around it in a helix as described  
5 above. The set angle causes the film to overlap by approximately 2 millimetres.

With reference to Figure 7, overlap of the film layers under the wires 4, 5 provides three thicknesses of film between the wires and inside the conduit. This prevents the wires from being melted out and exposed on the inside of the conduit, and  
10 provides a thicker surface to retain the wires for increased durability. The angle of the film being fed onto the mandrel ensures a conduit is formed with a particular pitch, which has been found to give a good compromise between the crush strength and the amount of film between the bead.

The method of pre-forming the film of the present invention could be extended  
15 to include additional folding of the initial film to produce films of more layers. Alternatively, more than one film could be used in the formation of the conduit of the present invention to increase the thickness of the conduit wall and thus the walls strength, yet still providing a conduit that is flexible.

Heated conduits formed by the method described above may reduce the build  
20 up of condensation in the conduit and may also offer a means to maintaining the temperature of humidified gases flowing through the conduit. Heated conduits are used commonly as gases transportation pathways in applications such as for Continuous Positive Airway Pressure (CPAP) therapy. In such conduits where the pathway includes conductive wires to heat gases flowing through the pathway, the  
25 corresponding connectors, at least at one end of the conduit, will include an electrical connection suitable for connection with the humidified gases source in order to supply electrical energy to the conduit heater wires.

The pre-forming of a tape with embedded heater wire, in accordance with one aspect of the present invention, confers the advantage of accurately locating the wires  
30 relative to the tape edge in a process that is more easily controlled than when applying the wires directly to the tube forming mandrel.

The provision of a crease in the tape, in accordance with another aspect of the present invention, confers the advantage of defining the preferred deformation modes of the conduit wall, such that the tube wall will predominantly be caused to bulge outwards on bending or contraction of the conduit.

**CLAIMS:**

1. A method of continuously forming conduit comprising:  
providing a thin polymer ribbon,  
heating said ribbon to soften said ribbon,  
forming a crease approximately midway across said ribbon, said crease being substantially parallel with said ribbon,  
supplying said folded ribbon having leading and trailing lateral edges, spirally around a former rotating and advancing said conduit, with the leading edge of each turn of ribbon overlapping the trailing edge of a previous turn of ribbon on the former and the trailing edge of each turn underlapping the leading edge of a succeeding turn, and  
applying a bead of molten plastic material to said lapping edges of adjacent turns of ribbon, such that said bead welds said adjacent edges.
2. A method of continuously forming conduit as claimed in claim 1, wherein said crease is formed by passing said folded film through at least one set of crease rollers, said crease rollers in a creasing region shaped according to the profile of said crease.
3. An apparatus for forming a conduit comprising:  
a means for supplying a thin polymer ribbon,  
a heating means for heating said thin polymer ribbon,  
a creasing means for forming a crease in said ribbon after being heated by said heating means, approximately midway across said ribbon, said crease being substantially parallel with said ribbon,  
a means for delivering said creased ribbon having leading and trailing lateral edges, spirally around a former, with the leading edge of each turn of ribbon overlapping the trailing edge of a previous turn of ribbon on the former and the trailing edge of each turn underlapping the leading edge of a succeeding turn to form said conduit,  
said former adapted to rotate and advance said conduit,  
a means for applying a bead of molten plastic material to said lapping edges of adjacent turns of ribbon, such that said bead welds said adjacent edges.

4. A conduit formed by a method according to any one of claims 1 or 2.

**1/10**



**Figure 1**

**PRIOR ART**

2/10

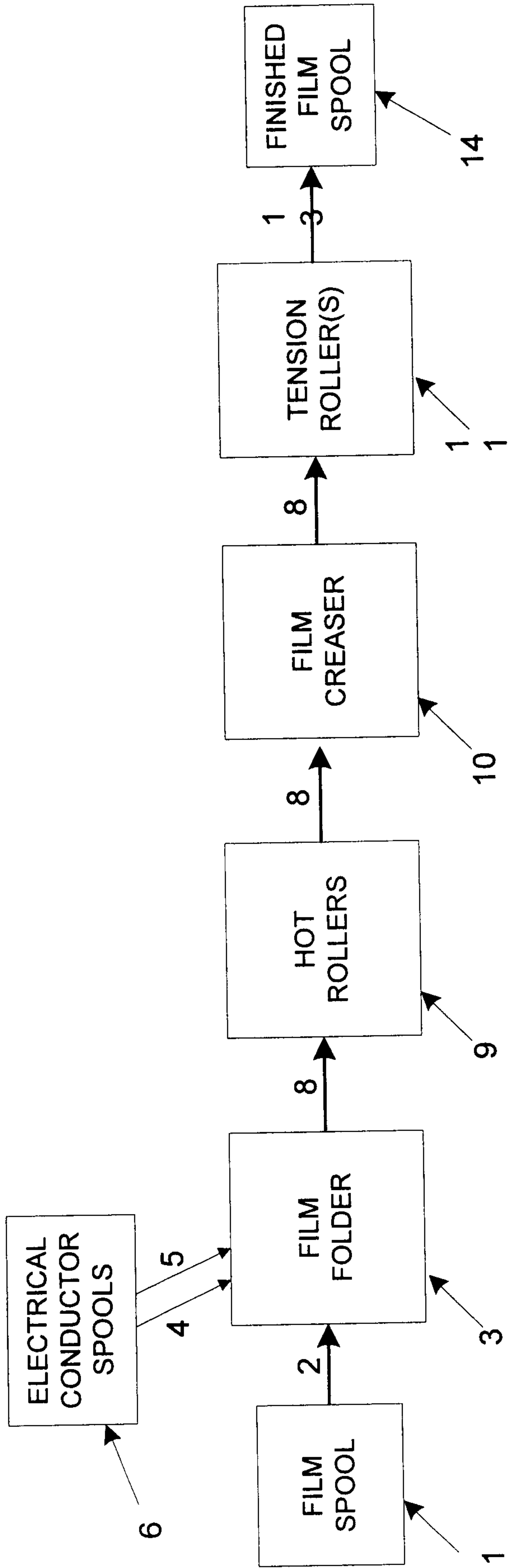

Figure 2

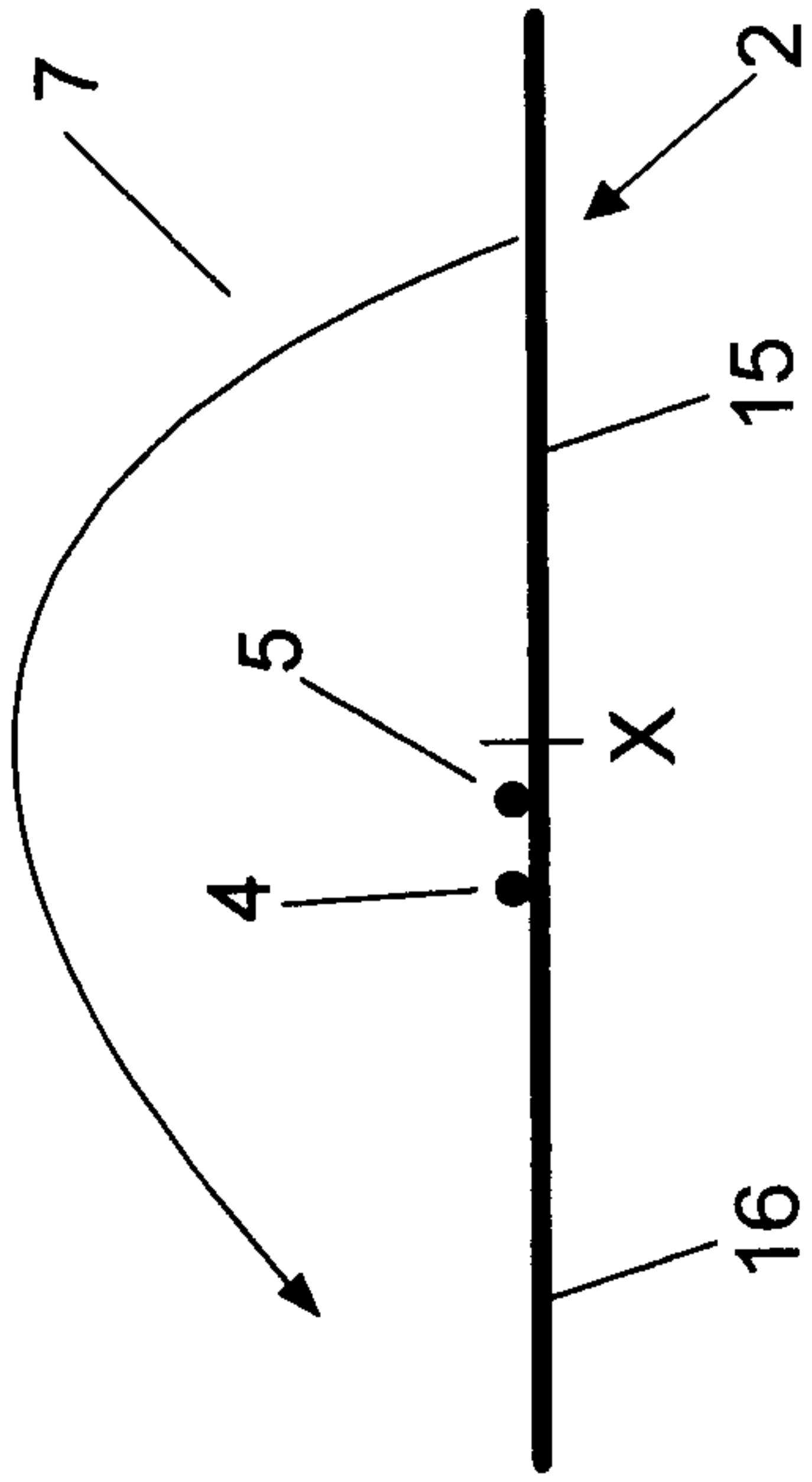

Figure 3

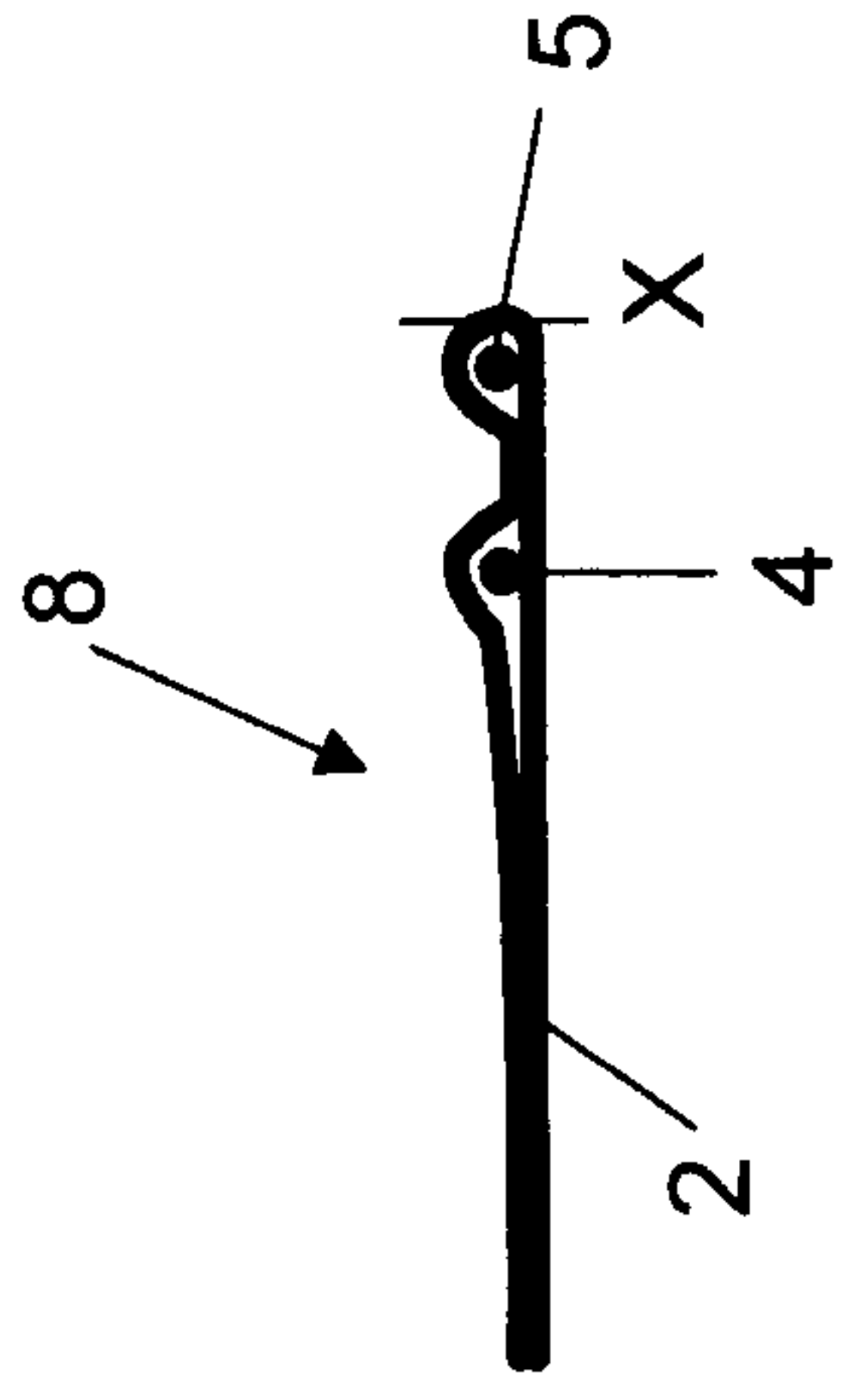

Figure 4

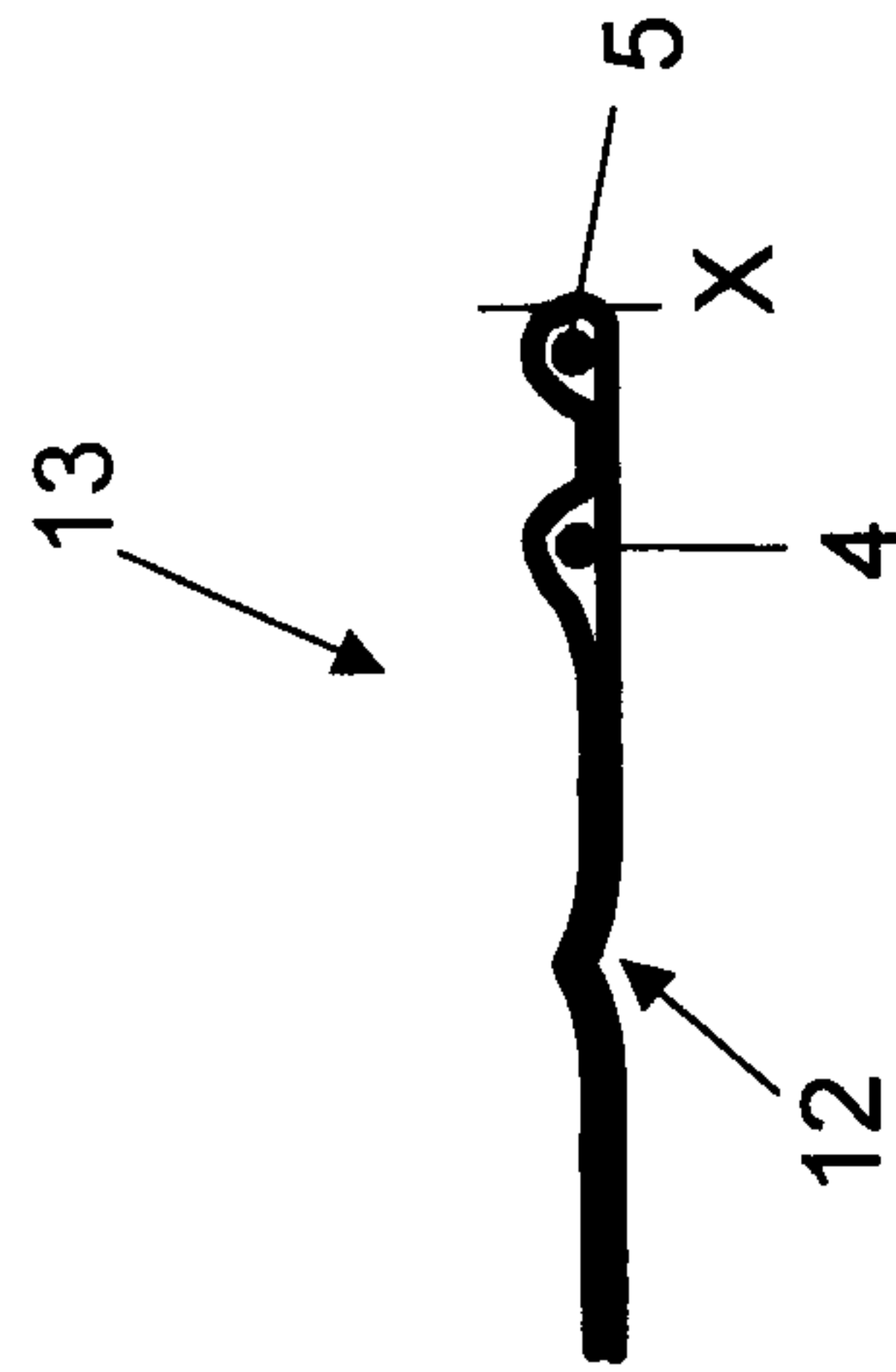

Figure 5

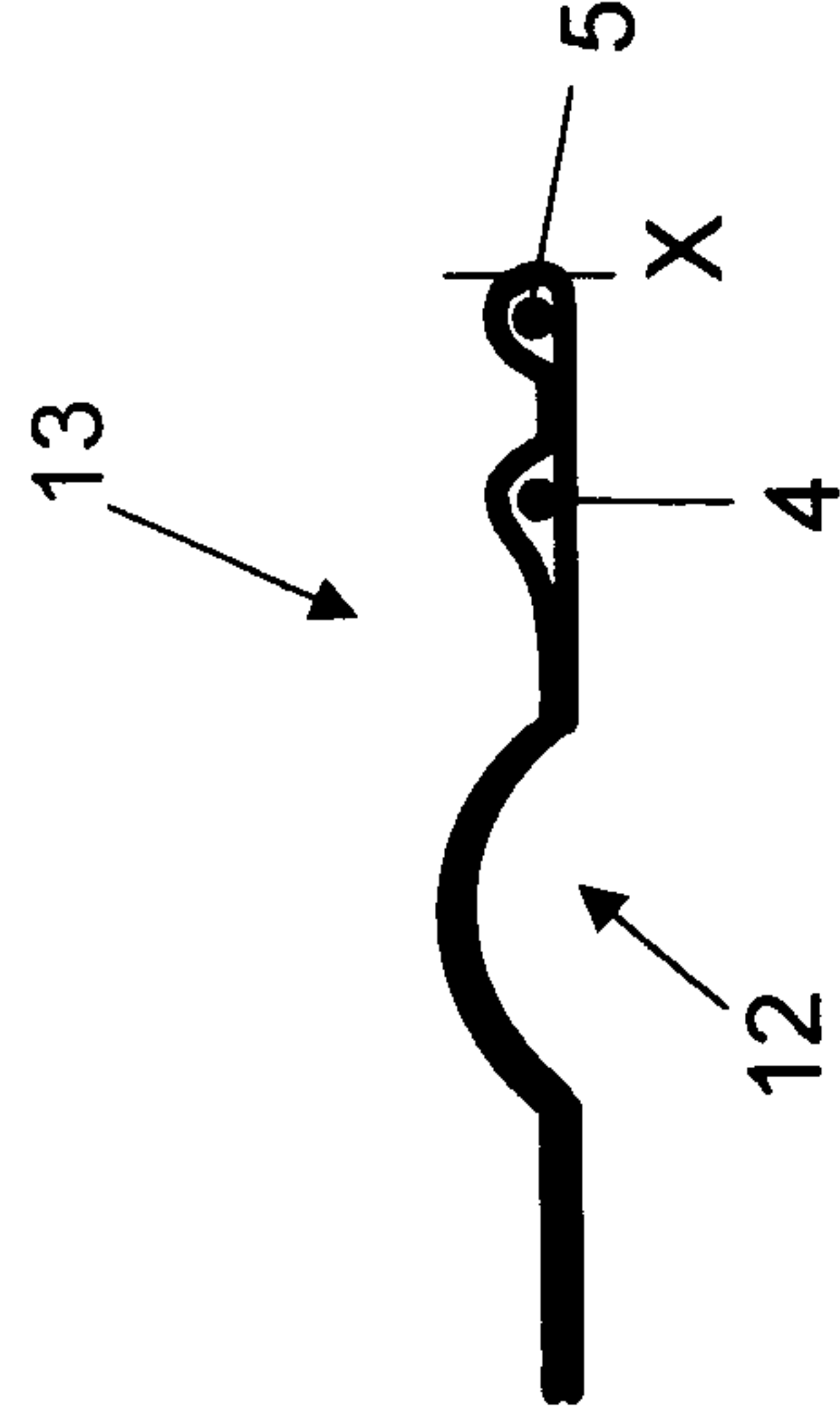

Figure 6

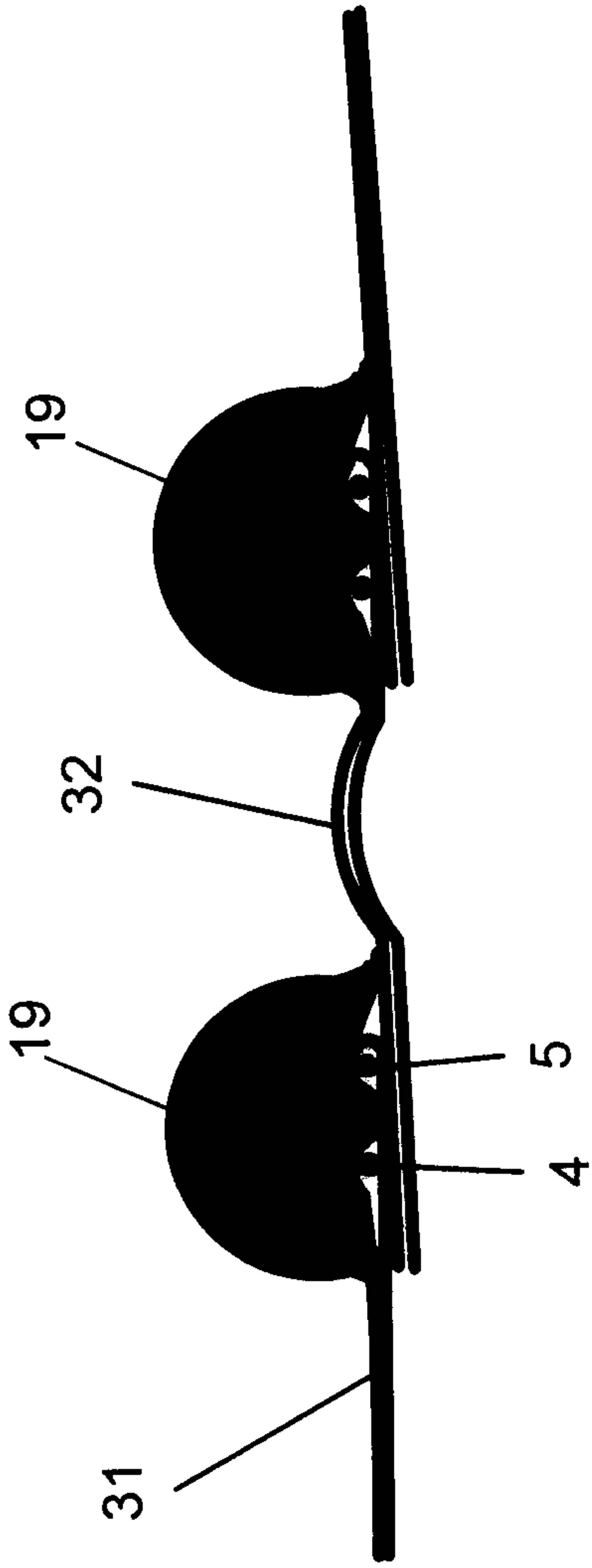

Figure 7

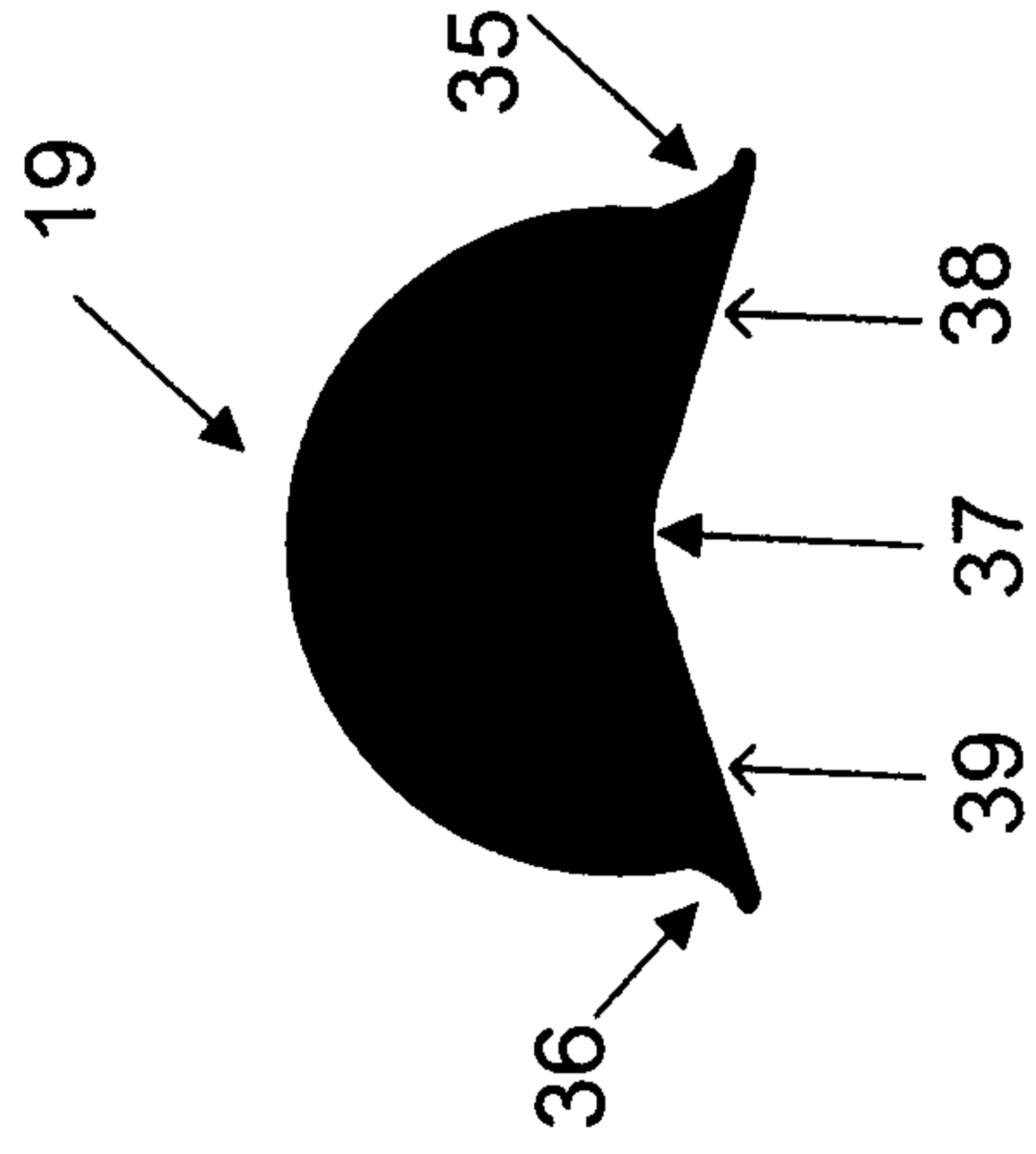

Figure 13

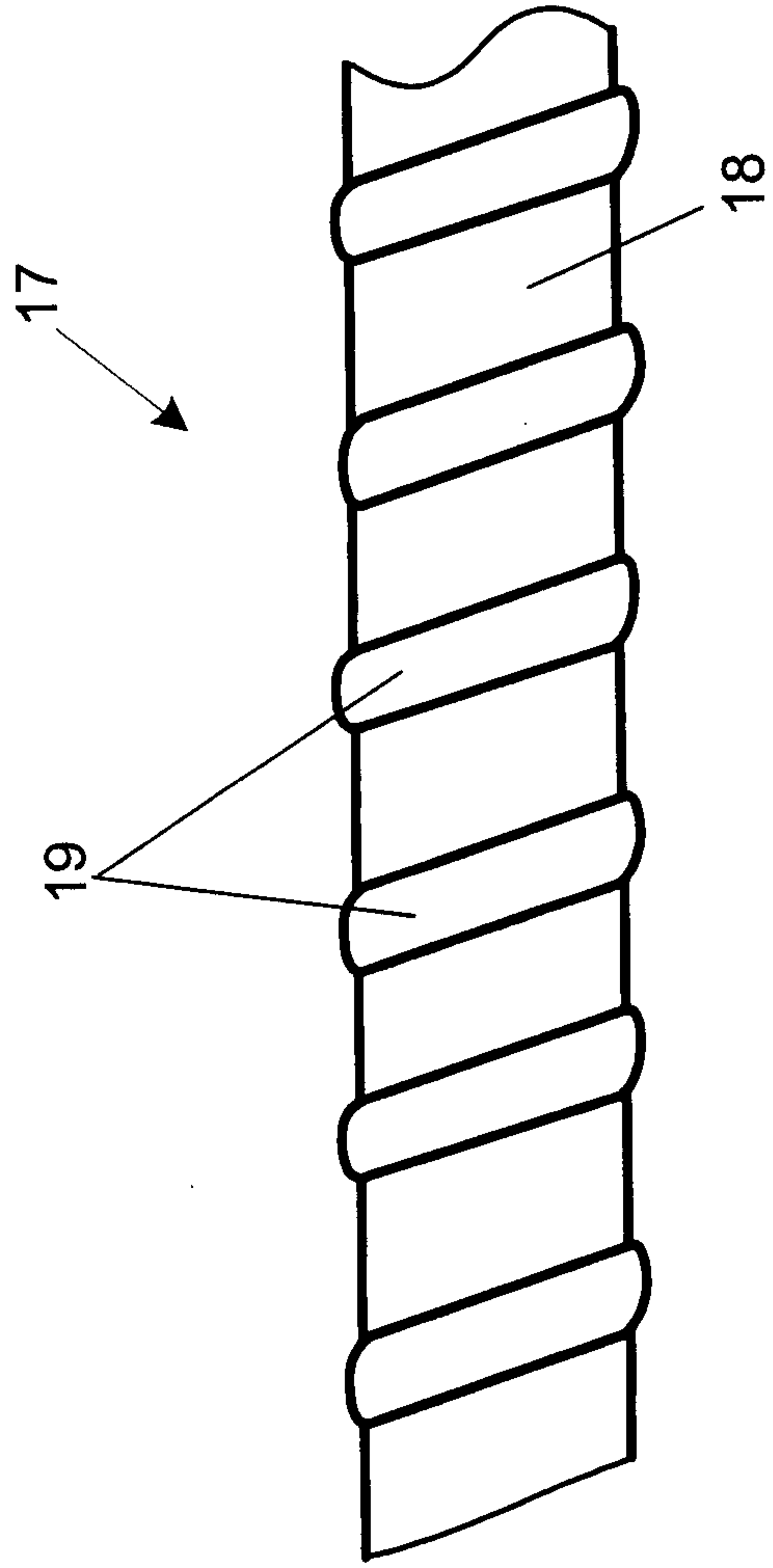

Figure 8

5/10

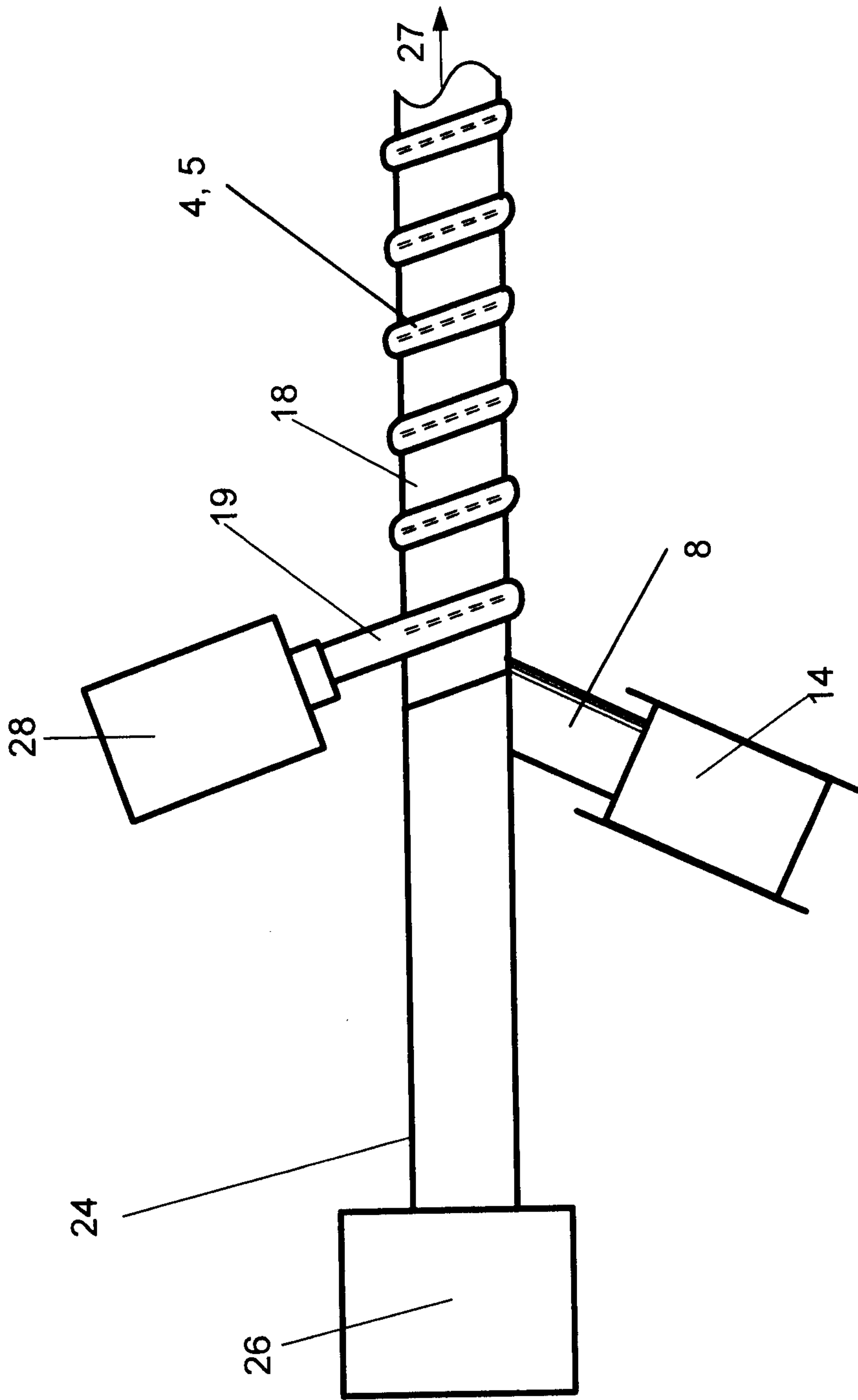

Figure 9

6/10

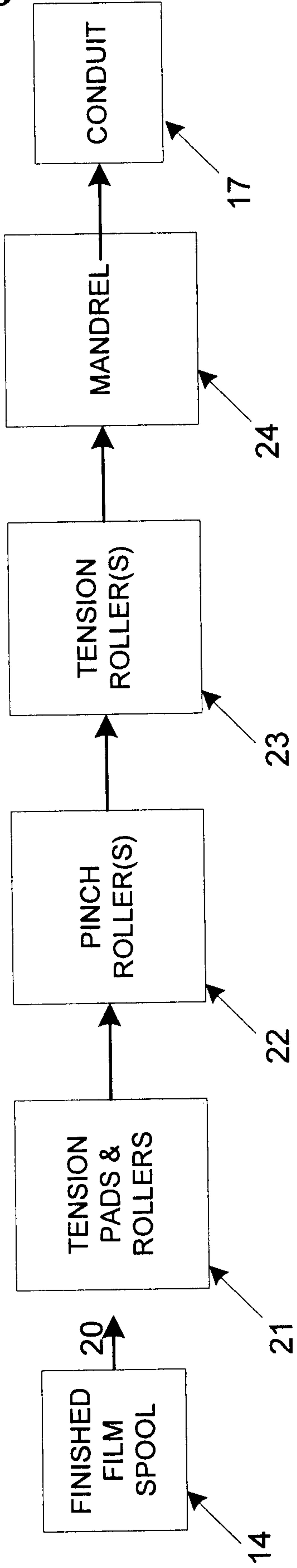

Figure 10

7/10

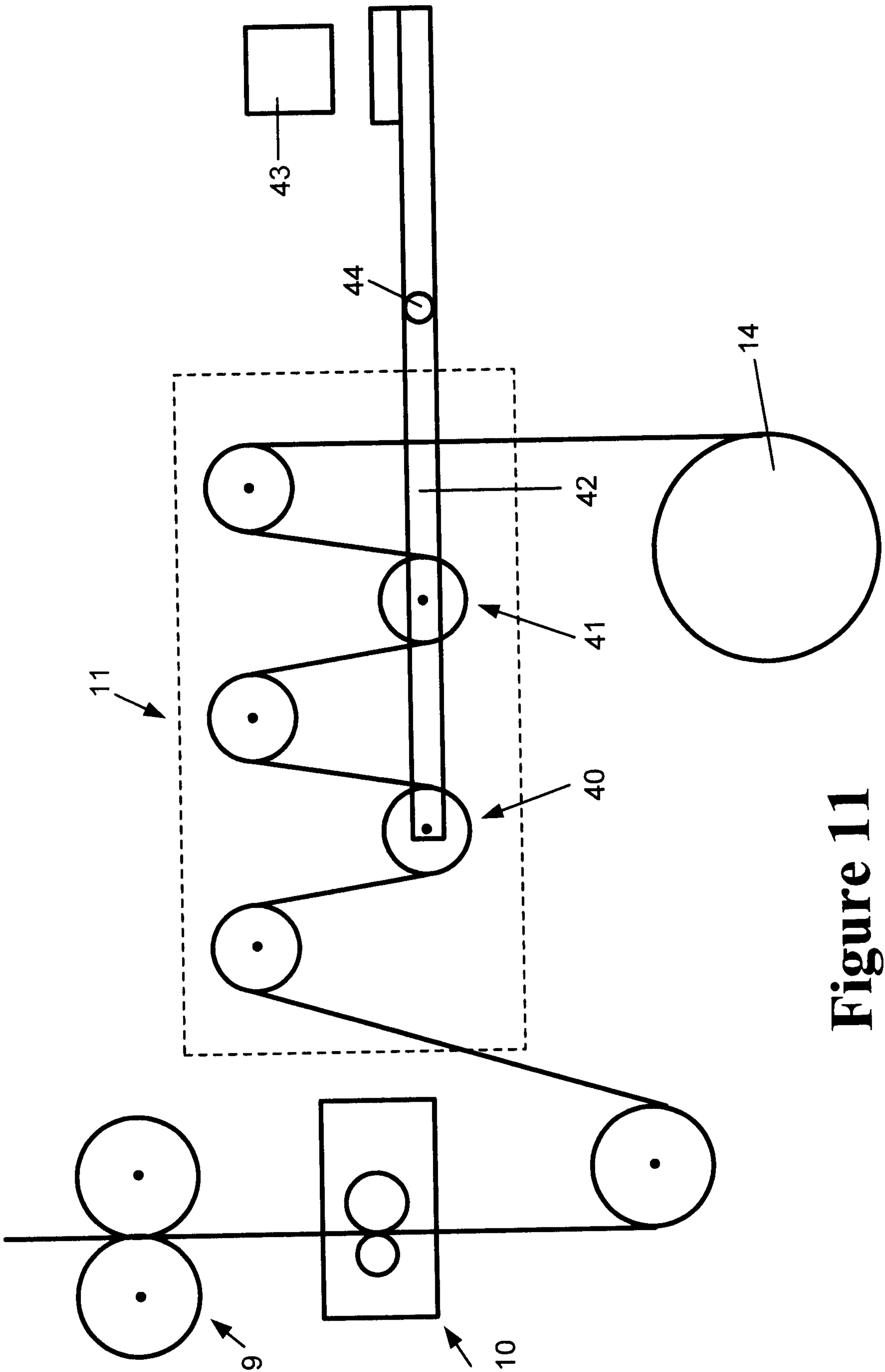

Figure 11

8/10

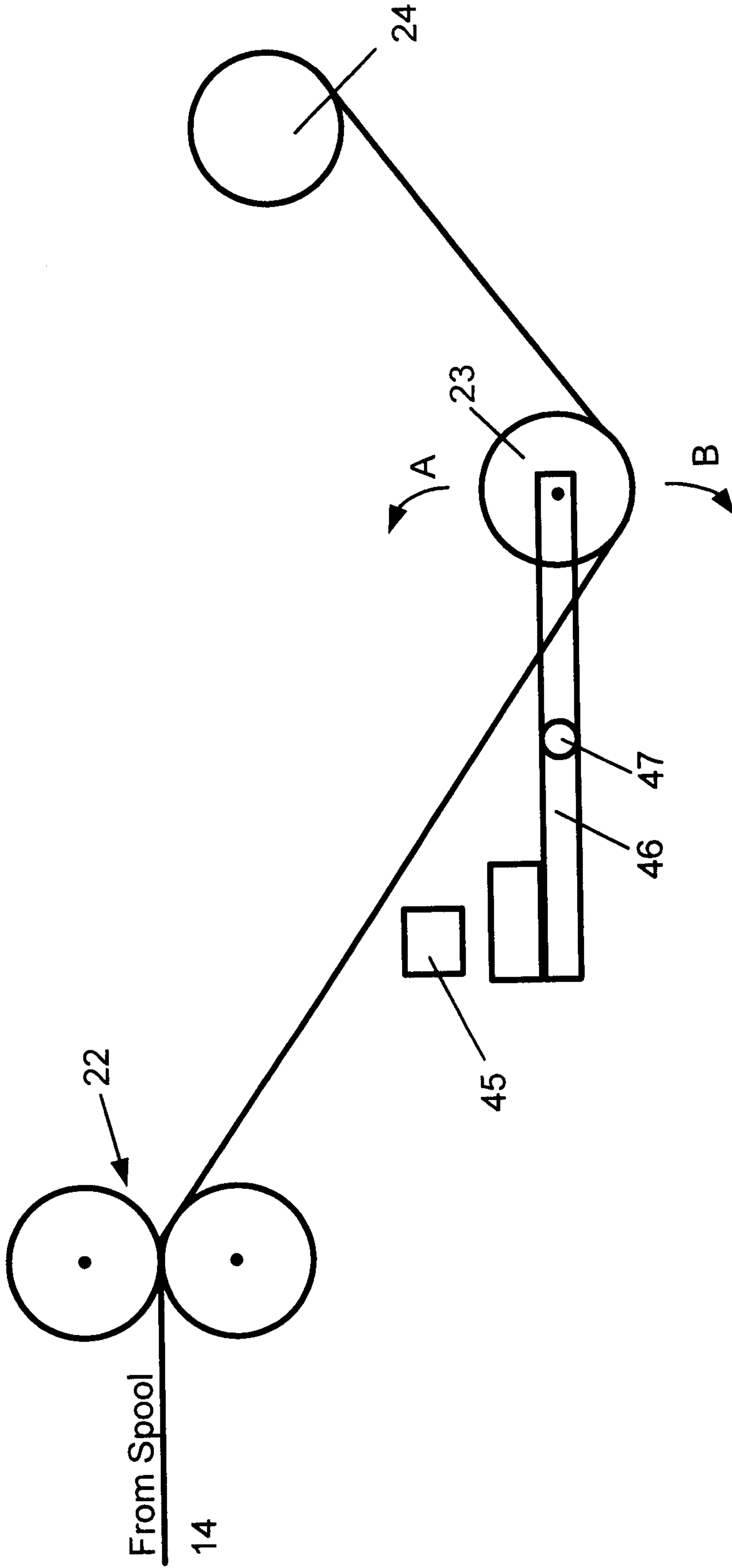

Figure 12

9/10

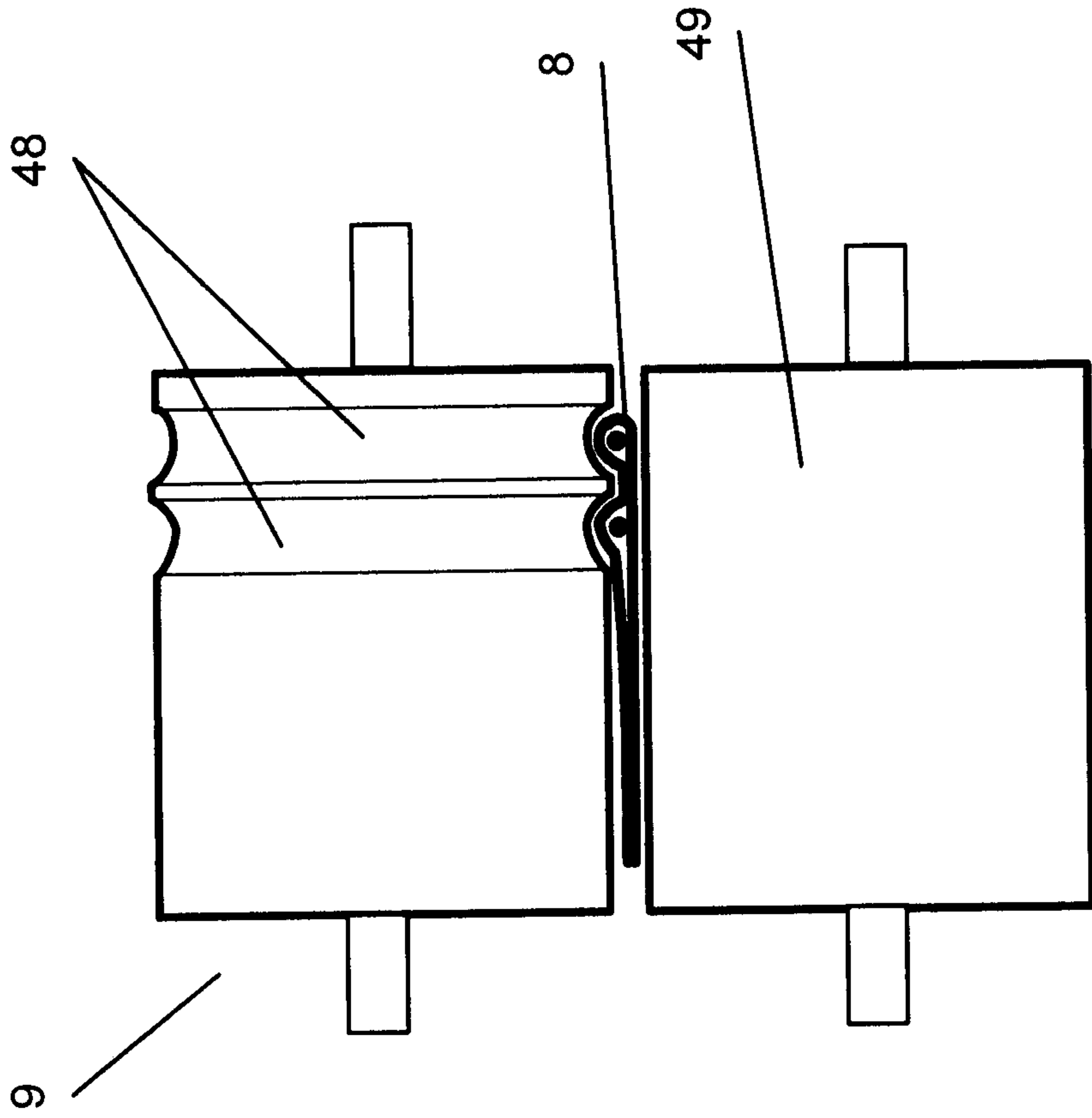

Figure 15

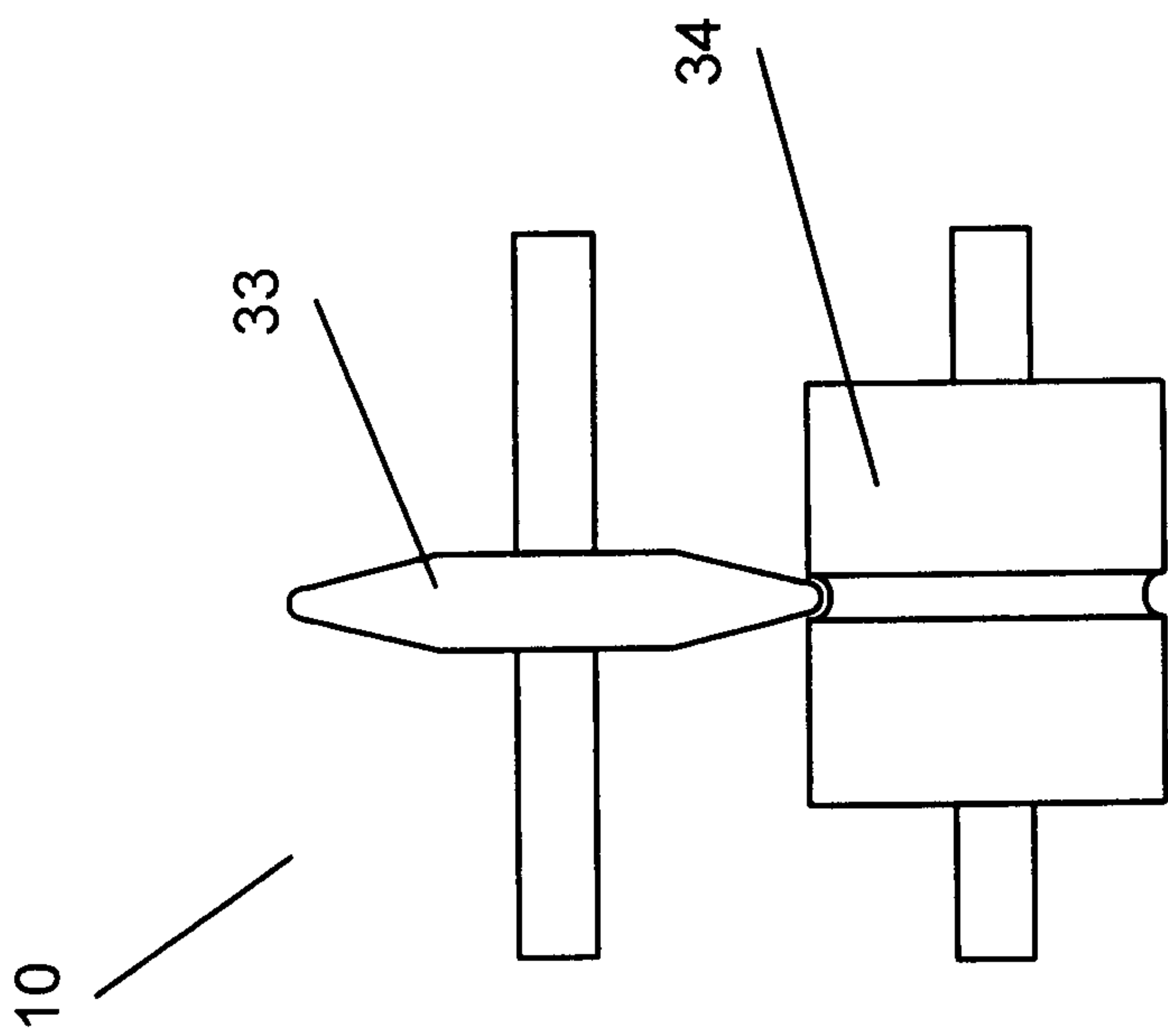

Figure 14

10/10

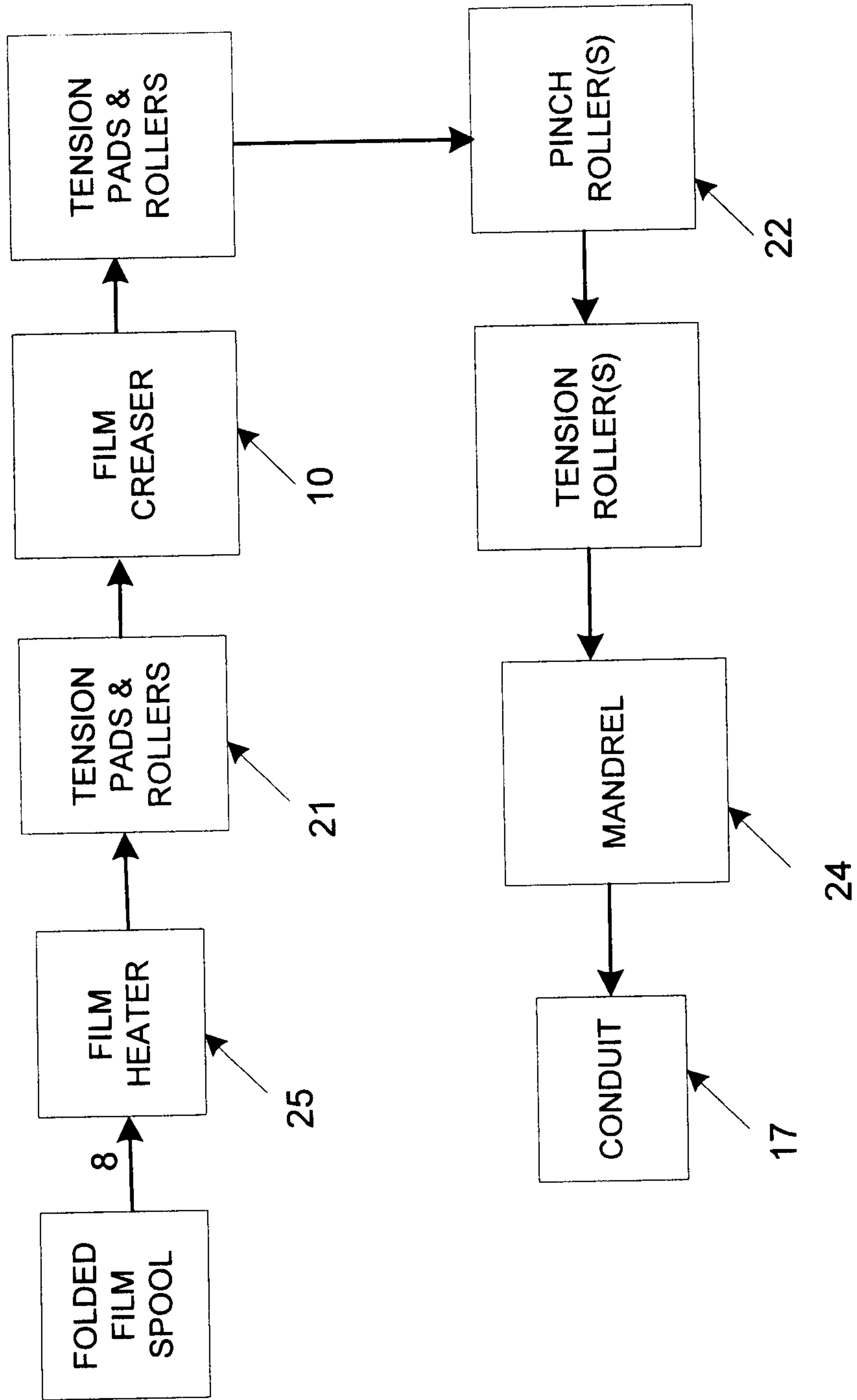

Figure 16

