

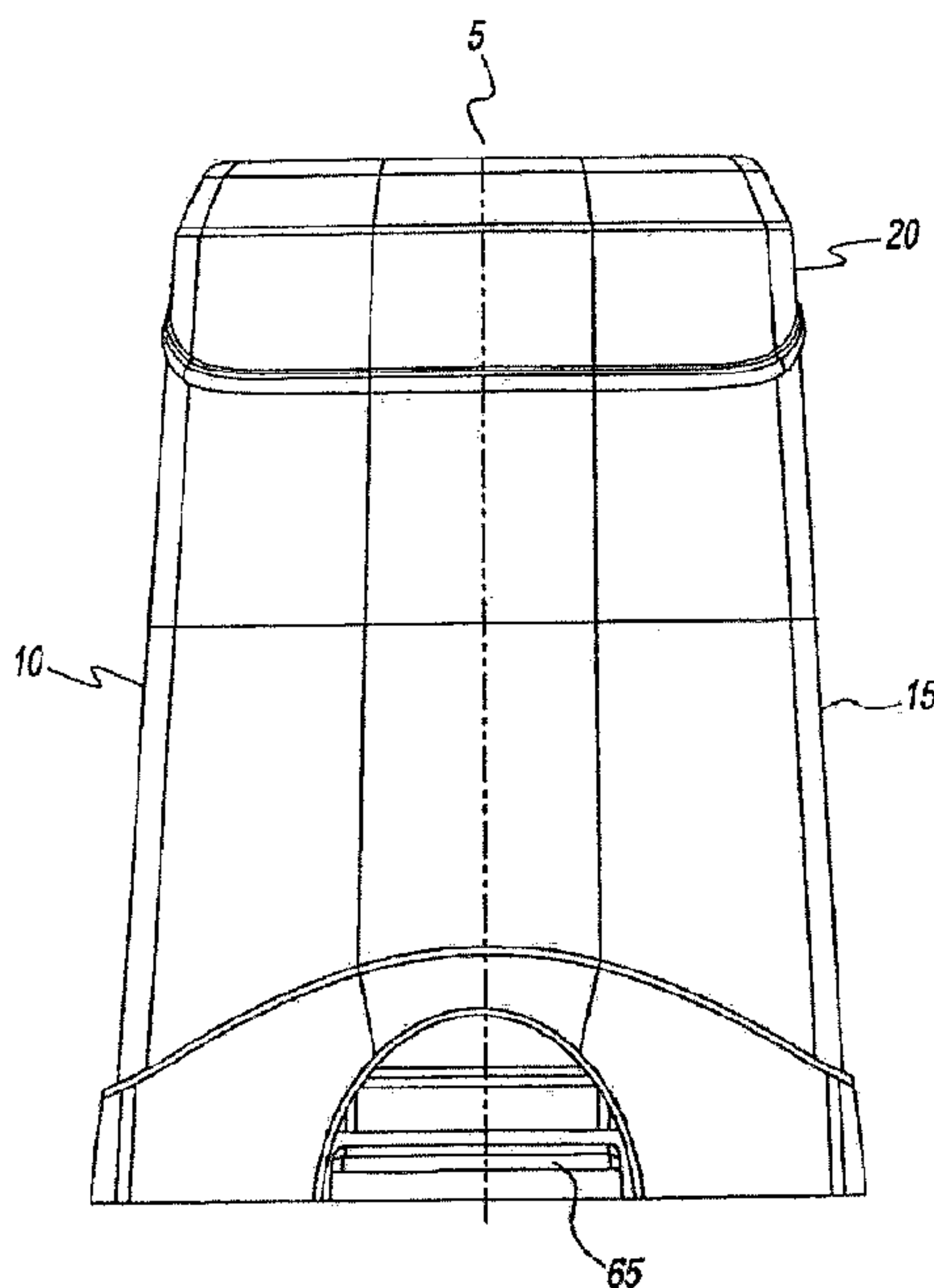

(22) Date de dépôt/Filing Date: 2004/08/30  
(41) Mise à la disp. pub./Open to Public Insp.: 2005/03/02  
(45) Date de délivrance/Issue Date: 2018/04/17  
(62) Demande originale/Original Application: 2 814 249  
(30) Priorité/Priority: 2003/09/02 (US60/499,443)

(51) Cl.Int./Int.Cl. *B65F 1/10* (2006.01),  
*B65F 1/06* (2006.01), *B65F 1/14* (2006.01)  
(72) Inventeur/Inventor:  
CHOMIK, RICHARD S., US  
(73) Propriétaire/Owner:  
EDGEWELL PERSONAL CARE CANADA, ULC, CA  
(74) Agent: SMART & BIGGAR

(54) Titre : DISPOSITIF AUTOMATIQUE DE MISE AU REBUT DE COUCHES PAR TORSION  
(54) Title: AUTOMATED TWIST DIAPER DISPOSAL APPARATUS



(57) Abrégé/Abstract:

A tubing refill cassette for an automated waste disposal apparatus is able to supply flexible tubing for sequestering waste packets. The cassette comprises an outer wall having top and bottom surfaces and two side surfaces, and an inner wall having top and bottom surfaces and two side surfaces. The flexible tubing is positioned between the outer and inner walls. The cassette also has a rim having top and bottom surfaces and two side surfaces and positioned between the outer and inner walls. The rim emanates from the top surface of one of the outer wall or the inner wall and extends partially towards the other wall. The bottom surface of the rim faces the flexible tubing. The rim incorporates on its top surface a plurality of protrusions.

55410-57D2

### Abstract

A tubing refill cassette for an automated waste disposal apparatus is able to supply flexible tubing for sequestering waste packets. The cassette comprises an outer wall having top and bottom surfaces and two side surfaces, and an inner  
5 wall having top and bottom surfaces and two side surfaces. The flexible tubing is positioned between the outer and inner walls. The cassette also has a rim having top and bottom surfaces and two side surfaces and positioned between the outer and inner walls. The rim emanates from the top surface of one of the outer wall or the inner wall and extends partially towards the other wall. The bottom surface of the rim  
10 faces the flexible tubing. The rim incorporates on its top surface a plurality of protrusions.

55410-57D2

**AUTOMATED TWIST DIAPER DISPOSAL APPARATUS**

This application is a divisional of Canadian Patent Application Serial No. 2,814,249 filed April 26, 2013 which is a divisional of Canadian Patent Application Serial No. 2,479, 484 filed August 30, 2004.

**BACKGROUND OF THE INVENTION**

5           The present invention relates generally to a waste disposal apparatus and, more particularly, to an automated apparatus particularly suited for the sanitary and odorless disposal of waste such as soiled diapers and a cassette for use with this apparatus.

**Description of the Related Art**

10           There are a number of systems for disposing of waste materials such as soiled diapers. The systems are often touted as a convenient way to dispose of such waste materials and reduce or eliminate any odor that may emanate from the materials. An example of such systems is U.S. Patent No. 5,147,055 which  
15           discloses a diaper container that includes an activated charcoal filter to retain and absorb odors within the container.

          Most waste receptacles are fitted with a lid designed to contain odors when the lid is closed. However, most lids are not designed to be perfectly air-tight in respect of their receptacles, or  
20           after repeated use become less-than air tight, permitting malodor to emanate from the receptacles even when they are closed. Even with the most air-tight containers, upon opening the container, the noxious odors escape into the area giving an extremely unpleasant sensation to the person attempting to add more trash to the  
25           receptacle. Location of the receptacles in a remote location is

55410-57D2

inconvenient and generally unsatisfactory.

5 Numerous receptacles have been proposed for temporarily holding diaper waste. These receptacles typically employ one of several approaches to reduce the emanation of malodor from the receptacle, which may be characterized as the use of making agents, odor sorbent material, inner lids or seals, air locks or sealed packaging.

10 Another problem with trash receptacles is that they tend to retain noxious odors even after the trash is ultimately removed. After a period of time a thorough and complete cleaning of such receptacles is necessary.

15 The scented diaper pail has been commercially available for many years. Scent is added to the diaper pail in the hope of hiding the smell of the malodor by producing a smell that masks the malodor to the olfactory senses. The problem with such pails is that the masking smell itself can often become irritating to the consumer, as well as the fact that most scented diaper pails lose their masking effect after a period of time.

20 A particularly difficult trash to retain for ultimate disposal is diapers. Diapers are typically stored and accumulated in a container. The cumulative odor of diapers being stored within the container frequently reaches such an offensive level that the diapers must be disposed of before the container is full. The latter leads to a large use of container liners such as bags, and excessive emptying operations. Excessive emptying operations can be of particular concern as one hesitates to leave the infant unattended or to carry the infant and the soiled diapers to a remote location. A further problem associated with such containers is that the containers themselves over time tend to retain the malodor even when no  
30 diapers are present in the containers. Therefore a thorough and complete cleaning of such containers is often necessary to reduce the lingering odor. Further, as many diaper disposal receptacles are

55410-57D2

not child-proof, toddlers playing around the container may inadvertently open the container to allow odors to escape or the child may reach in to touch soiled diapers.

5 European patent application No. 0005660 describes a device for disposing kitchen refuse in packages enclosed by flexible tubing derived from a tubular pack of tubing surrounding a tubular guide. The device includes a tube sealing mechanism. The tubing passes from the pack over the top of and then down the guide to a position beneath the guide where it has been closed by fusion to provide a receptacle within the guide means. When this receptacle is full of refuse, a lever is manually operated to actuate an electro-mechanical apparatus including clamping and fusion devices that travel round closed tracks to perform the four-fold task of drawing the receptacle down below the tubular guide, fusing the tubing walls together to seal the top of the receptacle, sealing the tubing walls together to provide the closed base of the next receptacle and dividing the tubing by heat at a location between these two fusion locations to separate the filled package. There are a number of disadvantages with this device including the need for latches to prevent the wheels extending from the heating elements from inadvertently returning up the central track portions (as opposed to following the outer track portions as they should). A further disadvantage is that the heating element must be at least the width of the tube in order to seal the tube all the way across thereby preventing, for example, the escape of odors from the waste.

20 Another popular approach to disposing of such diapers has been with a device using a tube twisting mechanism to form a pouch about the diaper. As an example, see the disclosures of U.S. Patent Nos. 4,869,049, 5,590,512, and 5,813,200.

30

55410-57D2

U.S. Patent No. 5,813,200 to Jacoby, et al. discloses a device for disposing of soiled diapers in twisted packages. The device has a container body with a hinged base, a hinged lid, and an upward cylinder secured within the container body. A tubular core rests on a portion of the upward cylinder to allow rotation there between. A flexible tube or sleeve rests on a portion of the tubular core with the tubing being circumferentially pleated as stored. Springs are fixed to the container and project radially inward to engage a package formed from the tube. The springs are equally spaced around the interior of the container to hold the package during the forming of a twist in the tube.

The device disclosed in U.S. Patent No. 5,813,200 is used to form a series of packages enclosing objects. The top of the flexible tubing is pulled upwards and tied into a knot. The closed end formed by the knot can then form the bottom of a package with the sidewalls formed by the tubing. The object is inserted and rests against the tubing near the knot. A rotatable interior lid is put into place and rotated such that the unused tubing and the tubular core rotate with respect to the package that is being formed. The package being formed does not rotate because it is held in place by friction between it and springs. Thus a package is formed between the knot and a first twist. Subsequently, objects are disposed and twisted in a like manner to form discrete packages with twists between them.

Devices such as that disclosed in U.S. Patent No. 5,813,200 are a convenient way of disposing of soiled diapers. A disadvantage of the system is that the twists between packages may become unraveled, thereby allowing groups of diapers to collect within the tubing, which makes emptying the container more difficult. Further, the twists do not create a continuous, complete seal and, therefore, may allow odor to escape from a package. Increasing the twists between packages may eliminate the above disadvantages but this

55410-57D2

requires the use of additional tubing.

Another example of a device used to decrease odors that emanate from diaper waste is disclosed in U.S. Patent Nos. 6,370,847 and 6,516,588, both issued to Jensen, et al. These related patents disclose a sealable diaper-disposal system that includes a container body, a tubular core on which flexible tubing is stored, and a tube-sealing mechanism having a pair of heating elements. The flexible tubing is pulled from the tubular core and passed between the pair of heating elements. The tube-sealing mechanism operates to move the pair of heating elements toward each other to fuse the width of the tubing, and away from each other to allow the tubing to be pushed into the lower portion of the container body.

From the above it can be understood by those having ordinary skill in the art that there are a number of disadvantages associated with prior art waste disposal devices using flexible tubing to form packets for disposal of waste materials. It is clear that a device is needed that will eliminate the disadvantages described above. Such a device should be relatively economical to purchase and operate, ensure that the seals between packets are complete and cannot come undone, and be easy to operate.

There is disclosed herein a waste container for sanitary disposal of waste including a container body defining a waste bin and an opening that provides access to the waste bin; a support mounted to the container body adjacent the opening, the support having a flange extending therefrom that is configured for mounting a tubing cassette above the waste bin, wherein the support encloses less than all of the opening to the waste compartment so that waste can be passed through the opening and into the waste chamber. A tubing cassette is mounted to the flange of the support. A tube twisting/sealing means forms individual waste packets from tubing that is dispensed from the tubing cassette.

55410-57D2

The present waste container with an automated twisting feature includes, a tubing cassette rotationally mounted to the flange of the support and a retention means for preventing rotation of a waste packet containing tubing portion when the tubing cassette is rotated to create a twist in the tubing. The flange may be configured to allow rotation of the tubing cassette. The cassette can be rotated by electrical power by a motorized rotating grip ring to create a closure twisting action of the flexible tubing when sequestering a waste packet. The motorized apparatus for the sanitary disposal of waste can also provide a plunging device with a suitable plate or disk for contacting the twist closure of the flexible tubing and downwardly pushing the flexible tubing for a predetermined distance from the tubing refill cassette's storage compartment, providing sufficient space for depositing a waste packet.

The described waste container has an upper or head compartment located on top of the waste container encompassing an apparatus comprising a drive plate mounted to the tubing cassette, a drive gear assembly engaged with the drive plate, and a motor mounted to the upper compartment apparatus and having an output shaft that rotates the drive gear when the motor is activated, the power from the motor being transmitted through the multiple gear assembly. A timing circuit can be employed for activating the motor to rotate the tubing cassette one of a predetermined amount of time or a predetermined number of times. A manually operated switch can be used for activating the motor.

The upper or head portion of the container serves also as lid over the lower receptacle compartment or waste bin of the waste container. The lid or upper compartment of the waste container can be hingedly attached to the container body for enclosing the opening to the waste bin. The lid or head portion of the container

55410-57D2

can be secured with a latch device. In addition, the hinge itself can include a latching mechanism or a biasing means to retain the lid in an open position. A foot pedal assembly is attached to the lid for opening the lid. Such assemblies are well known to those of  
5 ordinary skill in the art.

The waste container described herein includes a container body defining a waste bin and an opening that provides access to the waste bin; a support mounted to the container body adjacent the opening, the support having a flange extending therefrom that is configured for rotational mounting of a tubing cassette above the  
10 waste bin, wherein the support encloses less than all of the opening to the waste bin so that waste packs can be passed through the opening and into the waste bin.

According to one embodiment of the invention, a cassette  
15 comprises an outer wall having a top surface, a bottom surface and two side surfaces and an inner wall having a top surface, a bottom surface, and two side surfaces. Flexible tubing is positioned between the outer wall and the inner wall. A rim has a top surface and a bottom surface and two side surfaces and is positioned  
20 between the outer wall and the inner wall. The rim emanates from the top surface of either of the outer wall or inner wall and extends partially towards the other wall. The bottom surface of the rim faces the flexible tubing and the rim incorporates on its top surface a plurality of protrusions.

25 There is also disclosed herein a downward thrusting plate attached by a scissor slot assembly to a screw-type gear drive which is powered by an electrical motor through a gear transmission assembly. The activated thrust plate is extended downwardly to push onto the twist-locked flexible tubing  
30 sequestering a waste pack, the waste pack thereby being urged into the container waste bin compartment.

55410-57D2

The apparatus is further equipped with a plunging plate to effect a downward thrusting motion at the twist-tightened upper end of the flexible tubing enclosing the waste pack pulling additional tubing from the refill cassette so as to provide a pouch-like space below the cassette core opening in order to receive the next waste pack, thereafter repeating the twist-tightening motion.

Furthermore, there is described herein an automatically controlled apparatus for individually sequestering packs of odorous waste in a length of flexible tubing which is dispensed and depending from a core tube portion inside a tubular refill cassette. The apparatus combines a lower compartment or bin for receiving and storing the tubing enclosed waste packs and an upper compartment for accommodating and securing the electronically powered and controlled system for sequestering each pack of waste in the flexible tubing. The sequestering event is initiated by an electrical actuator causing to start first, a rotational movement of the tubing refill cassette or dispenser so as to effect a twist tightening of the flexible tubing which depends downward from the tubing refill cassette into the lower compartment of the waste receptacle, the waste packet sequestering part of the tubing being held by a retention or clamping device; and secondly, activate the downward motion of the thrusting plate to urge the twist-locked waste packet into the waste receiving bin and simultaneously provide another length of flexible tubing for the next deposit of a waste packet. These and other aspects are disclosed in more detail herein below.

The disclosed apparatus further provides a means for cutting the twist-tightened upper portion of the flexible tubing individually enclosing and sequestering a series of waste packs, which cutting means are suitable located at a position above the twisted portion of the tubing and below the refill cassette enabling removal of the tubing sequestered waste pack from receptacle bins.

55410-57D2

The rotational twist-tightening of the flexible tubing so as to lock can be reinforced by an adhesive containing device or ribbon segmentally positioned on the inside surface of the tubing material, the adhesive being activated by the twisting of the flexible tubing. Alternatively, the flexible tubing material can comprise clinging properties for reinforced twist stabilization and sealing effect. The adhesive location can be placed on the inside of the flexible tubing at predetermined intervals or segments suitable for sequestering the waste packets.

A further aspect of the present apparatus can be found in a film grip ring for gripping or holding the flexible tubing in place in order to prevent the inadvertent release of the stored refill tubing from the rotating cassette during the twisting operation. This advantageous aspect assists in creating a measurably effective tight twist lock of the sequestered waste packet in the tubing segment.

Another feature of the disclosed apparatus comprises a trigger mechanism for actuating the thrust mechanism determining the start of the downward motion of the thrusting plate at the end or completion of rotational motion the core tube effecting the twist closure of the flexible tubing above the sequestered waste packet. The trigger mechanism can be initiated by a timing device or optical counter which actuates the thrust mechanism after a preset interval. The optical counter can be aided by a laser-optical detection device.

According to another embodiment of the invention, there is provided a waste storage device, comprising: a container body defining a waste bin having an opening that provides access to said waste bin, said container body having a support with a flange extending therefrom, said flange encloses less than all of said opening  
5 such that waste can be passed through said opening into said waste bin; a flexible tubing having a rim that is operably connected to said flange, wherein said flexible tubing is within said container body; and a sealing mechanism having an opening such that said flexible tubing passes through an opening in said sealing mechanism and forms a twist in said flexible tubing below the waste while the waste remains  
10 stationary.

According to another embodiment of the invention, there is provided a waste storage device, comprising: a container body defining a waste bin having an opening that provides access to said waste bin, said container body having a support with a flange extending therefrom, said flange encloses less than all of said opening  
15 such that waste can be passed through said opening into said waste bin; a cassette for dispensing flexible tubing having a rim that is operably connected to said flange, wherein said flexible tubing is within said container body; and a sealing mechanism having an opening such that said flexible tubing passes through an opening in said sealing mechanism and forms a twist in said flexible tubing below the waste while the  
20 waste remains stationary.

### **BRIEF DESCRIPTION OF THE FIGURES**

A more complete appreciation of the invention and the advantages thereof will be more readily apparent by the reference to the detailed description of preferred embodiments when considered in connection with accompanying figures,  
25 wherein:

55410-57D2

Fig. 1 is an elevational side view of an embodiment of the present waste container;

Fig. 2 is a sectional side view thereof;

Fig. 3 is an elevational view of a refill cassette embodiment of the invention;

Fig. 4 is a sectional side view thereof;

Fig. 5 is an elevational view of an embodiment of the refill twister apparatus;

Fig. 6 is a sectional view thereof; and

Fig. 7 is a sectional view of the extended plunger mechanism.

It is notable that like items depicted in different figures may be referred to by the same reference numbers.

An automatic device for the convenient and hygienic sequestering of waste packets is described herein. Waste packets are understood to comprise diapers or similar waste contents.

For the purpose of this disclosure, any device that closes off tubing at a point along the length of the tubing is considered a "tube-sealing means." Therefore, for example, fusion devices, which close off tubing with heating elements, and twisting devices, which close off tubing by inducing a twist, are considered "tube-sealing means." Several tube-sealing means are disclosed herein above in the background of the invention. Other exemplary tube-sealing means are disclosed in U.S. Patent Nos. 6,128,890 and 6,065,272, and U.S. Publication No. US 2002/0162304. In this description and the accompanying figures of the automated sequestering and disposal apparatus, reference is only made to a flexible tubing-twisting or twist-locking mechanism for closing off the flexible tubing to

55410-57D2

sequester the individual waste packets within the tubing as well as the associated downward placing of the sequestered waste packets by a plunger device.

5 The present disclosure describes an improvement over other waste disposal devices or systems in that it comprises an automatically controlled mechanism for sequestering the waste packets individually inside a flexible tubing bay of some length dispensed from a refill cassette. The hands-off embodiment features a motor-driven rotation of the refill cassette inner core tube portion  
10 thereby twisting the tubing of the waste packet which is held in place by the spring-aided holder/brackets. A driveshaft is connected to the motor through a gear assembly or transmission. The driveshaft is activated when the tubing twisting rotation is completed and the waste packet is closed off or sequestered in the tubing material. The  
15 driveshaft is connected by a pinion through the connecting scissor slots to the thrust plate of the plunger. The rotation of the driveshaft, i.e. a rod with a screw-type outer ridge, winds through the nut-like center hole of the pinion, which is thereby slidably moved along holding or locating means or rod causing the scissor connectors to  
20 extend and vertically move the thrust plate plunging or pressing down onto the twist-closure of the tubing portion sequestering the waste packet, which is consequently placed down deeper in the waste bin of the container.

25 The motorized two-step mechanism of the apparatus controlling the twisting and plunging of the automated waste sequestering operation can be manually turned on by pushing a button, preferably on top of the lid or head portion of the container. Alternatively, the mechanism may be controlled by a foot operated switch or lever. The depressed button contacts electrically the actuator of the apparatus  
30 motor, causing an initial twisting rotation of the cassette core tube. The rotation of the motor driveshaft being transmitted through a set

55410-57D2

of gears to the rotatory ring that engages the cassette rim through the small ridges projecting therefrom on top of the cassette when the hingedly attached upper head or lid compartment of the waste receptacle is closed.

5           The second step of the automated control of the waste sequestering mechanism causes a plunging device to downwardly thrust and extend onto the twist-locked waste packet enclosing tubing. Thus, the flexible tubing is pulled from the storage compartment of the cassette through a gap between the inner core tube and the rim atop  
10 the refill cassette.

          The lid can be opened by a foot operated or activated mechanism which acts upon the lid at the latch mechanism which causes the lid to be in the open position. A waste load is deposited into the open center of the cassette. Upon release of foot-operated  
15 mechanism, the lid is caused to close so that the motorized actuator mechanism acts by a cog gearing system causing it to rotate a cassette holding a tubing bag receptacle. The rotation accomplishes two activities for sequestering a diaper or similar waste load and dropping or moving the same downwardly into the tubing bag.

20           At the closed lid position, the actuator initiates the rotation force on the tubing cassette by the refill twister exerting pressure on the beveled ring surface of the cassette. The rotational movement is measured to continue until sufficiently tight twisting has been effected on the tubing bag so as to close the top opening and thereby retain the  
25 waste load. At the moment when the twisting or tightening by cassette rotation is complete for sufficient closure of the tubing tubular bag, a vertically dispensed gearing mechanism is turned on and causes a downward movement of the cassette holder and cassette with attached waste loaded tubular receptacle portion. This downward  
30 thrust is mediated through a scissor link assembly which stretches out

55410-57D2

to extend along the axis of the cassette opening, moving the sequestered waste load downward.

5 Simultaneous to the motorized rotational force input on the cassette rim, a film grip ring is activated to contact and clamp down on to the flexible tubing emanating and hanging over the top edge of the inner core tube of the tubing cassette. This contact prevents release of tubing from the storage compartment of the cassette during the rotational twisting operation.

10 Throughout this specification, the word "comprise" or variations such as "comprises" or "comprising" will be understood to imply the inclusion of a stated integer or group of integers but not the exclusion of any other integer or group of integers. The general embodiment of the present invention is best understood by reference to Figs. 1- 7 of the drawings.

15 Referring to Fig. 1, a waste container 10 is shown comprising a lower or waste storing bin compartment 15 and an upper lid or head compartment 20 with an optional activation start button 5.

20 The automated twist waste disposal apparatus useful for sequestering waste packets such as diapers in twist-sealable flexible tubing is illustrated in Figs. 1, 2, 3, and 4.

The disposal device 10 comprises top or lid portion 20 which comprises hingedly attached and latch-secured pivoting lid or cover configuration and a bottom or bin portion 15, having an approximately cylindrical or cone-like shape.

25 In Fig. 2, the lid portion 20 is shown to contain an apparatus for automatic control of twisting and lowering of tubing below the refill cassette. The apparatus comprises an upper body portion 21 and a lower body portion 22. More specifically, the lid 20 houses or contains the apparatus upper body 21, comprising an electronic motor-driven

55410-57D2

control gear assembly 110, an actuator 45, a rotatory grip ring or  
refill twister 35 for contacting and rotating the tubing refill cassette  
body 50 effectively twisting the flexible tubing 52. The tubing  
emanates through a gap 54 between the rim 57 of the cassette 50  
5 and the core tube 61, and is folded down through the open cassette  
tube core area 51 into the interior bin space 16 as partially shown in  
Figs. 3 and 4.

The lower body of apparatus 22 encompasses the removable  
refill cassette 50 as well as a retaining means or spring assembly 55  
10 positioned to hold the flexible tubing 52 which encloses a waste pack  
(not shown) in the bin space 16 during the twist-closure operation.  
The tubing cassette 50 houses a length of tubing material 52 for  
sequestering the waste packets sequentially in the waste bin space  
16.

15 The lid 20 secured by a hinge 381 to the waste bin 15 includes  
a latch 382. The waste bin 16 also includes a hinged base 19 for  
providing access to the lower interior of the waste bin space 16. The  
hinged base 19 includes a latch (not shown) for securing the hinged  
base 19 in a closed position.

20 The bottom rim 58 of the tubing refill cassette body 50 rests on  
a flange support or holding ring 70 which is affixed to the internal wall  
side of the bin 15 of the device 10. The flexible tubing material 52 is  
stored in a continuously folded manner in the tubing storage  
compartment 59 of the cassette 50.

25 Referring to Fig. 5, the gear assembly 110 in a housing or cap  
structure 155 of the upper body portion 21 of the electronic  
motor-driving apparatus has a motor 47 located near the gear idler  
25, which motor 47 is started when the manually depressed button 5  
on the lid 15 makes contact with the switch 95. The first action of the  
30 motor-driven gear assembly causes rotation of the refill twister 35

55410-57D2

comprising a tubular ring structure 36 which exhibits a notched bottom surface 130. This surface is situated to make contact with the top ring or collar of the refill cassette 50 so as to propel the cassette into rotational motion. The tubular refill twisting device 36 is provided with a ridge 150 (see Fig. 7).

Figs. 6 and 7 show a scissor link assembly 210 of the apparatus linked to a slideable U-joint type linkage 215. A pinion is saddled on a radially positioned carrier device or rod 360 with a bracket 225 while at one point attached to the linkage 210 connecting slidably U-joint type linkage 215, and at another point attached to a drive rod 235. The drive rod 235 comprising a screw-like wound surface is inserted into the nut-type center which can be centrally moved along the carrying means or rod 360 by the revolutions of the screw-type positioning rod so that the drive rod 235 rotations cause the scissor link connecting linkage 215 to move towards the center so as to move the plunger plate 40 vertically downward through open central portion 37 of the upper body 21 and the cassette core opening 62.

The twisting operation is further facilitated by the film grip ring 335 which, during the twisting operation, acts as a brake pressing onto the flexible tubing 52 atop the cassette core tube 61, and prevents the tubing 52 from being pulled out of the refill cassette 50 storage compartment 59 during the cassette rotation.

A revolution counting mechanism is included in the upper portion of the apparatus 21 controlling the twisting operation as well as the downward motion of the plunger 40.

Referring again to the illustrations of Figs. 3 and 4, the refill cassette 50 stores the flexible tubing 52 which emanates from the storage compartment 59 through the gap 54 between the rim 57 and the cassette's core tube wall 61 and then folds into the inner core area 62, hanging into the bin space 16 below. The rim 57 is provided with

55410-57D2

small ridges 580 for effectively engaging the refill twister 34, in particular, the notched bottom surface 130 of the refill twister when rotating the cassette 50 and the top portion of the flexible tubing enclosing the diaper deposit (not shown).

5 Taking reference again to Fig. 2, the lid portion 20 of this embodiment 10 can be opened by depressing a foot pedal arrangement 65 which acts through a push rod 66 on the hinge assembly 381 of the lid 20, exposing the core opening 62 of the refill cassette 50 for depositing a waste packet.

10 As further illustrated in Fig 2, the retention springs 55 are attached to the flange 70 and retain or hold a waste package (not shown) stationary while the rotating refill twister 35 causes the cassette collar or rim 57 to rotate the tubing cassette 50 inducing a twisting motion in the flexible tubing 52. As used herein, the term  
15 "retention means" shall include any retention device for retaining or restraining a waste package (not shown) in a stationary position while the cassette 50 and the flexible tubing 52 dependent through the cassette core opening 62 is rotated.

As used herein, the term "retention means" shall include any  
20 retention device for retaining a tubing enclosed waste package stationary while the flexible tubing 52 is rotated.

Although the present invention and its advantages have been described in detail, it should be understood that various changes, substitutions and alterations can be made therein without departing  
25 from the scope of the invention as defined by the appended claims. For example, components in one figure can be combined with components shown in another figure.

55410-57D2

While the invention has been described with respect to preferred embodiments, those skilled in the art will readily appreciate that various changes and/or modifications can be made to the invention without departing from the scope of the invention as defined by the appended claims.

CLAIMS:

1. A waste storage device, comprising:
  - a container body defining a waste bin having an opening that provides access to said waste bin, said container body having a support with a flange
  - 5 extending therefrom, said flange encloses less than all of said opening such that waste can be passed through said opening into said waste bin;
  - a flexible tubing having a rim that is operably connected to said flange, wherein said flexible tubing is within said container body; and
  - a sealing mechanism having an opening such that said flexible tubing
  - 10 passes through an opening in said sealing mechanism and forms a twist in said flexible tubing below the waste while the waste remains stationary.
2. The waste storage device of claim 1, wherein said waste storage device further comprises a lid operably connected to said container body such that said lid encloses said opening.
- 15 3. The waste storage device of claim 2, wherein said lid further comprises a plunging device that provides a downward thrusting motion at said twist in said flexible tubing enclosing the waste.
4. The waste storage device of claim 1, wherein said rim comprises a plurality of protrusions.
- 20 5. The waste storage device according to claim 1, wherein said waste storage device further comprises a foot pedal, wherein depressing said foot pedal causes a twist in the flexible tubing.
6. A waste storage device, comprising:

a container body defining a waste bin having an opening that provides access to said waste bin, said container body having a support with a flange extending therefrom, said flange encloses less than all of said opening such that waste can be passed through said opening into said waste bin;

5 a cassette for dispensing flexible tubing having a rim that is operably connected to said flange, wherein said flexible tubing is within said container body; and

a sealing mechanism having an opening such that said flexible tubing passes through an opening in said sealing mechanism and forms a twist in said  
10 flexible tubing below the waste while the waste remains stationary.

7. The waste storage device according to claim 6, wherein said cassette comprises an outer wall.

8. The waste storage device according to any one of claims 6 and 7, wherein said cassette comprises an inner wall.

15 9. The waste storage device according to any one of claims 6, 7, and 8, wherein said cassette comprises a bottom wall.

10. The waste storage device according to any one of claims 6, 7, 8, and 9, wherein said cassette comprises a rim, the rim defining a gap for dispensing said flexible tubing from said cassette.

20 11. The waste storage device according to claim 10, wherein said rim comprises a plurality of protrusions.

12. The waste storage device according to claim 10, wherein said rim is beveled.

13. The waste storage device according to any one of claims 6, 7, 8, 9, 10,  
25 11, and 12, wherein said cassette has a plurality of ridges.

81788303

14. The waste storage device according to claim 13, wherein said waste storage device further comprises a refill twister extending from said flange, wherein said refill twister comprises a notched surface that engages said plurality of ridges on said cassette.

5 15. The waste storage device according to claim 6, wherein said waste storage device further comprises a foot pedal, wherein depressing said foot pedal causes a twist in the flexible tubing.

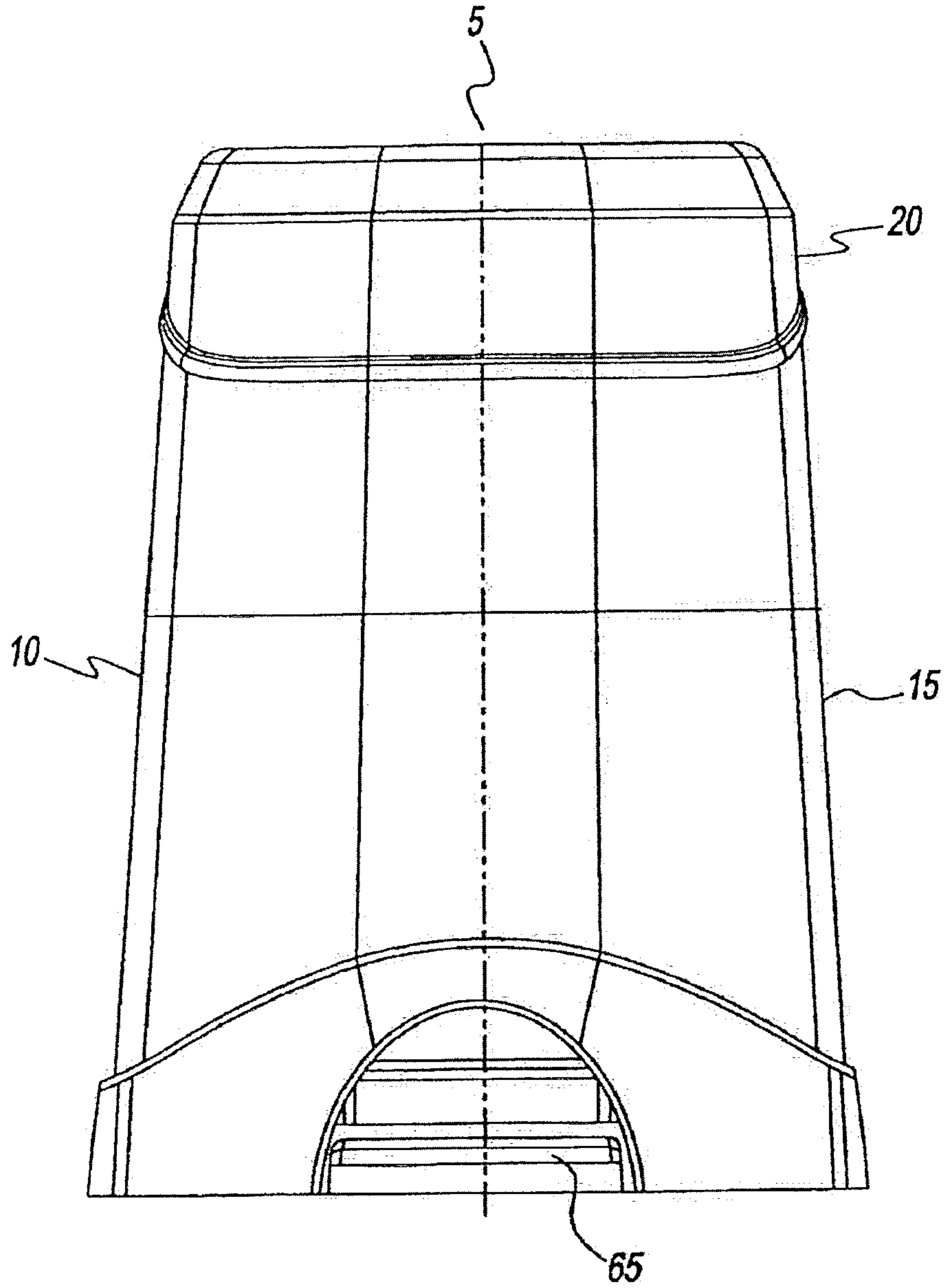

*Fig. 1*

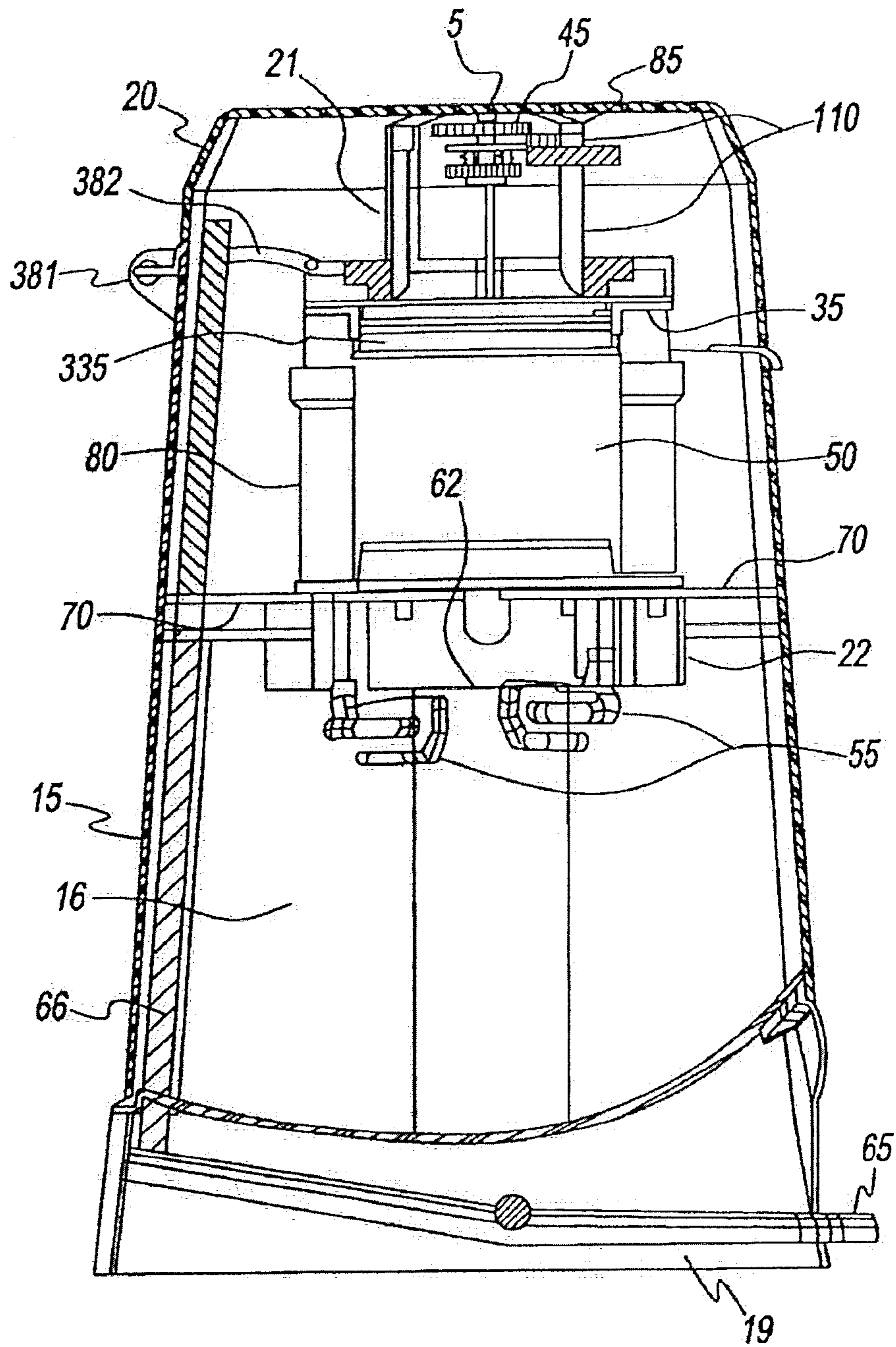

Fig. 2

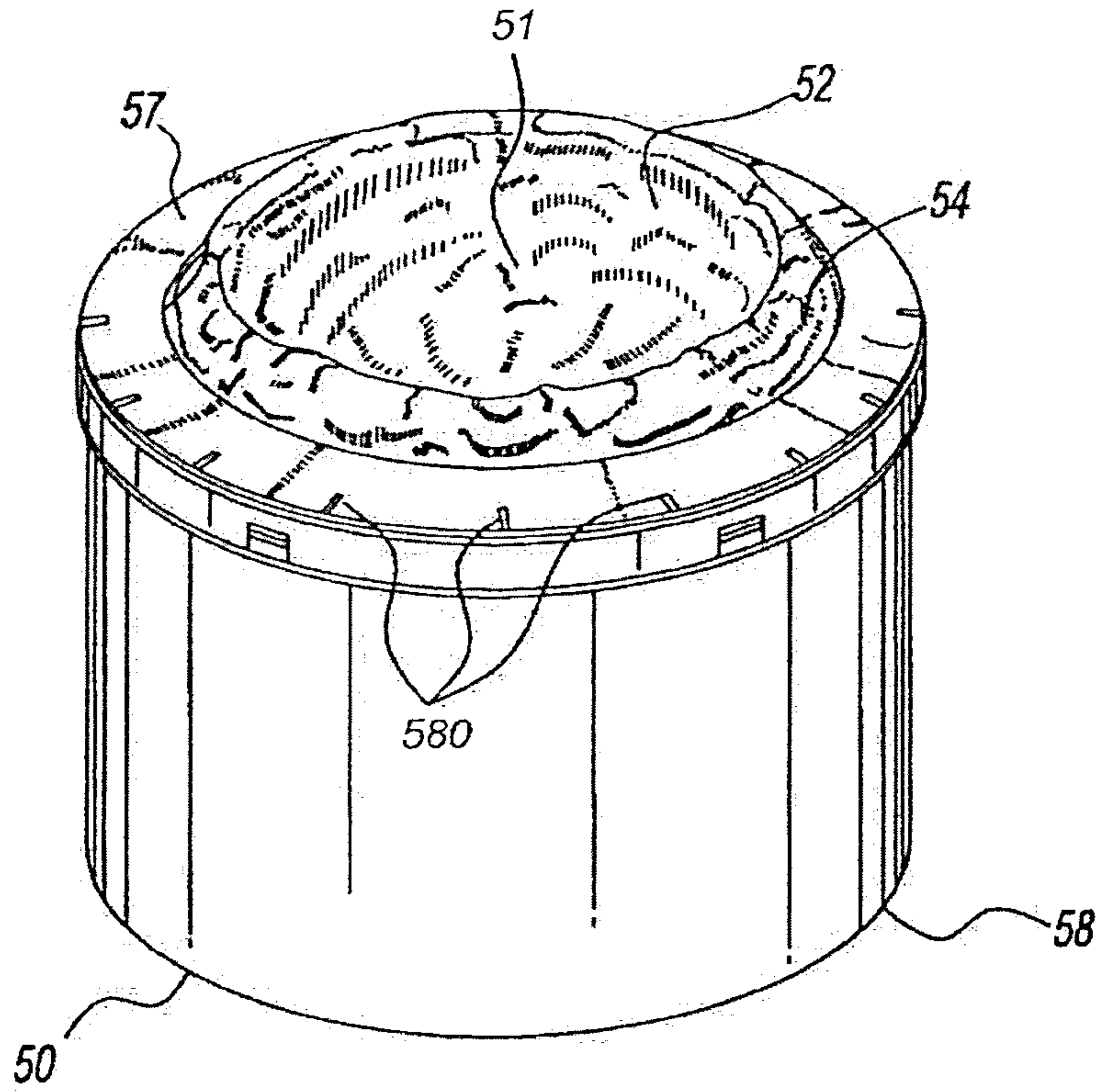

Fig. 3

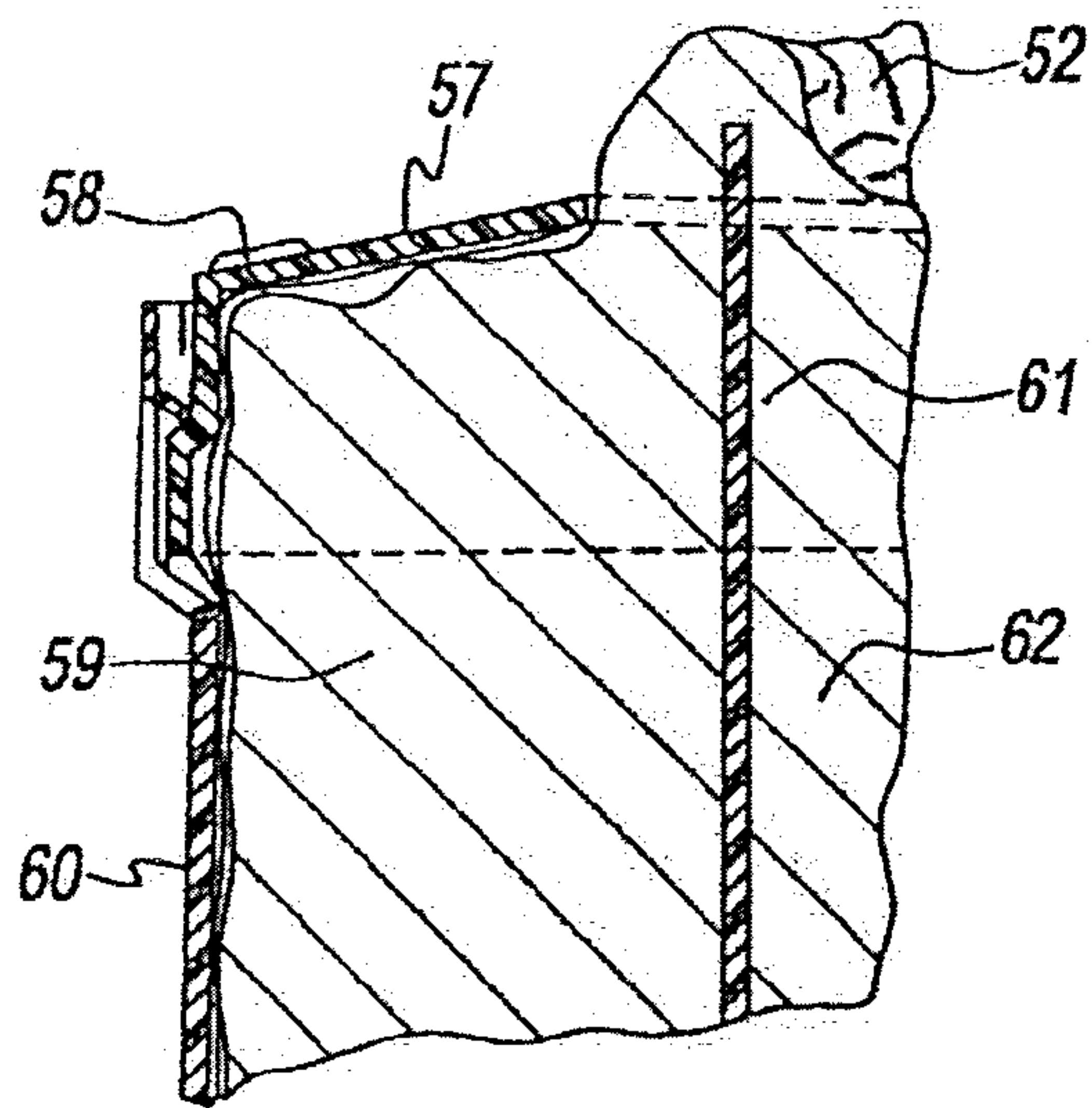
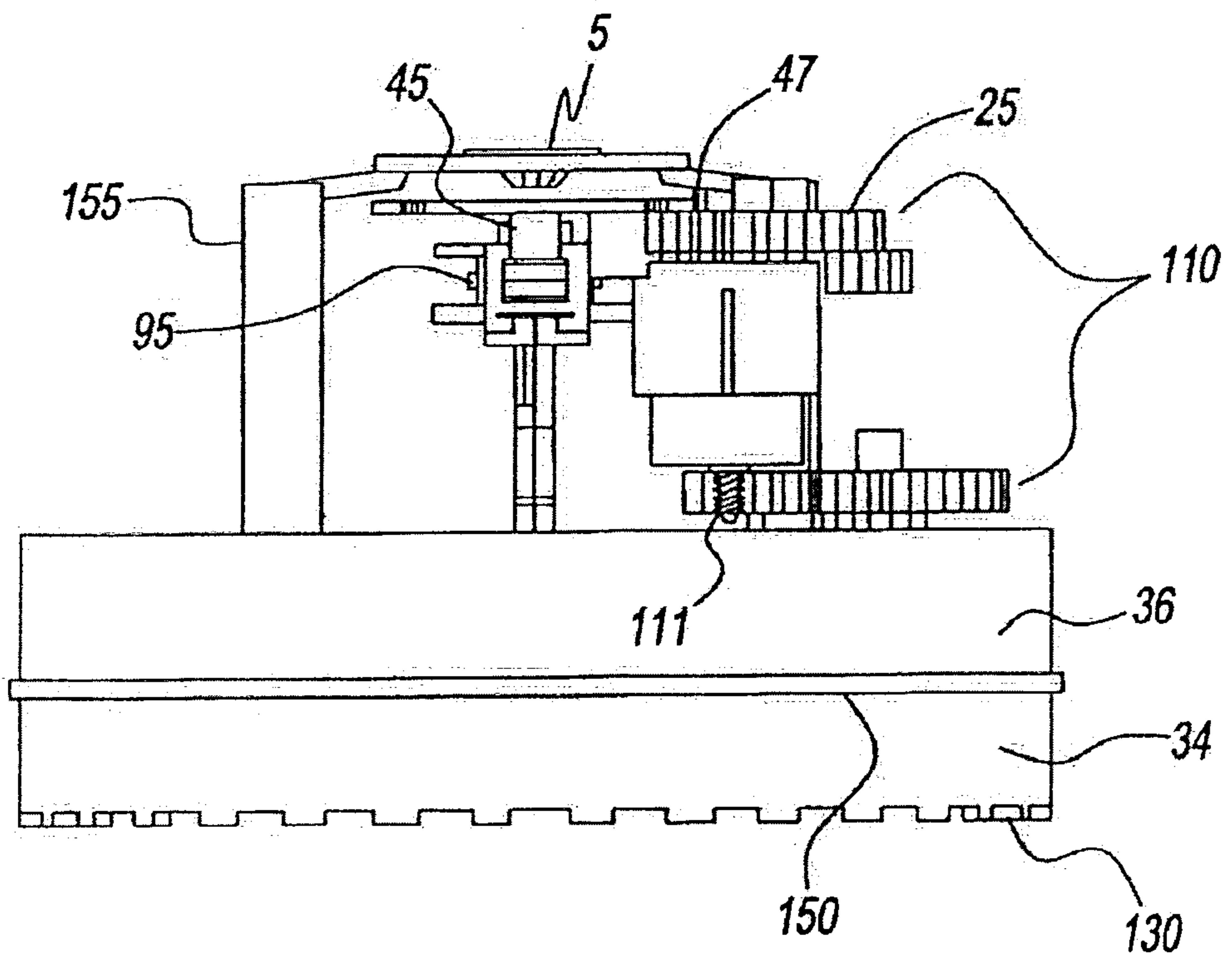

Fig. 4



*Fig. 5*

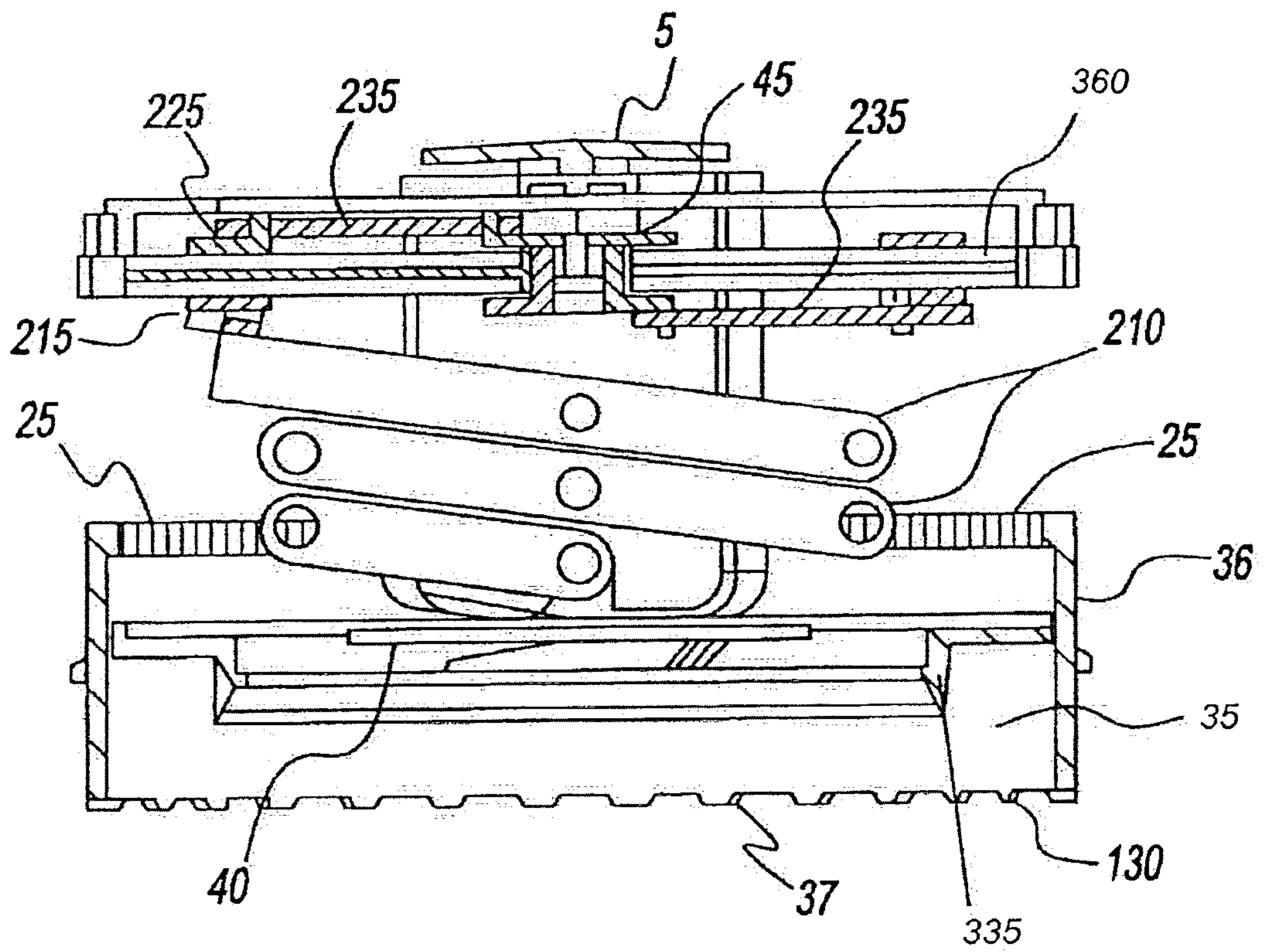

Fig. 6

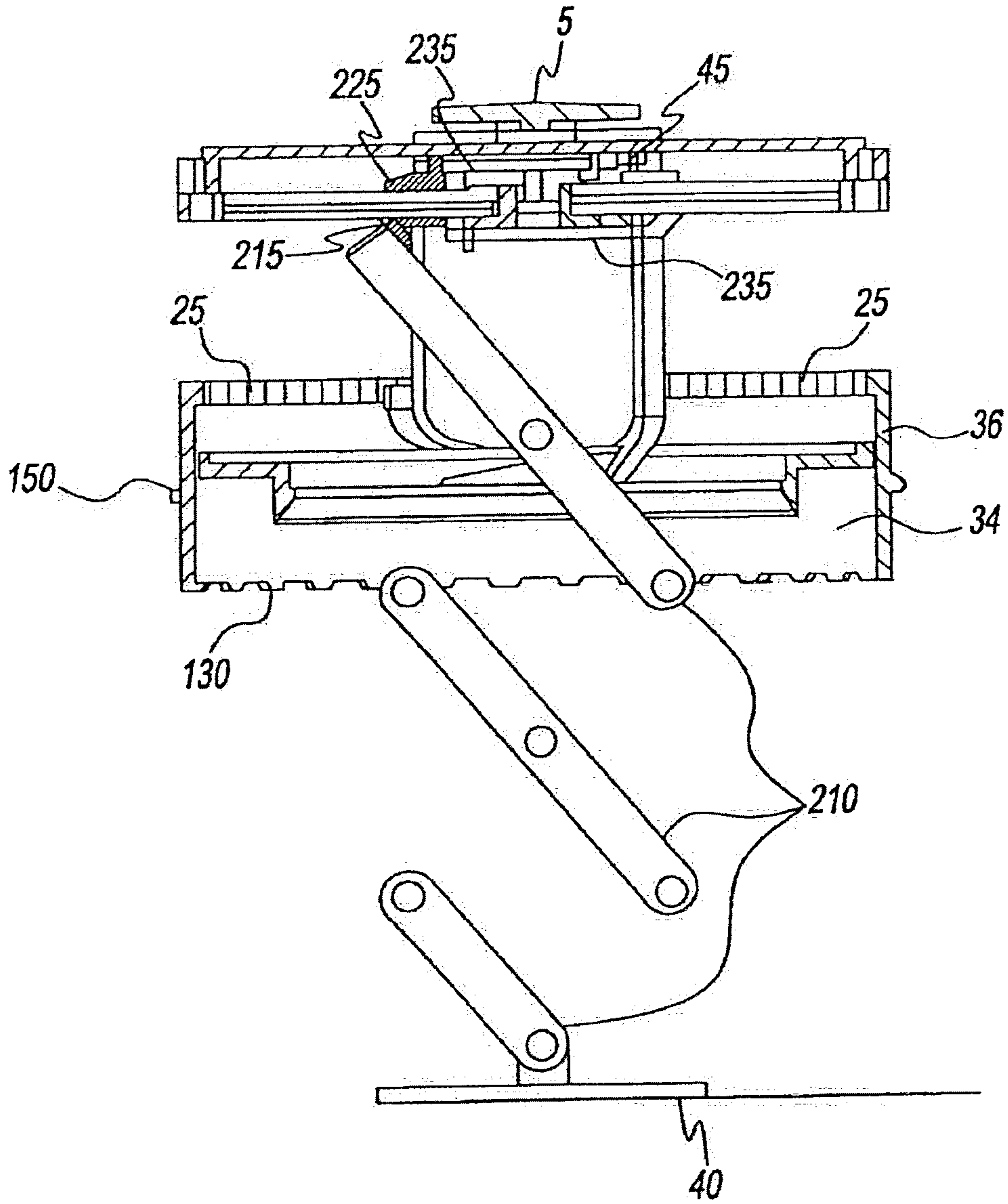

Fig. 7

