



INTERNATIONAL APPLICATION PUBLISHED UNDER THE PATENT COOPERATION TREATY (PCT)

(51) International Patent Classification ⁶ : A23L 1/308, A61K 31/715, A23L 1/054, 1/0526	A1	(11) International Publication Number: WO 00/57727 (43) International Publication Date: 5 October 2000 (05.10.00)
(21) International Application Number: PCT/NL00/00187 (22) International Filing Date: 21 March 2000 (21.03.00) (30) Priority Data: 1011680 26 March 1999 (26.03.99) NL (71) Applicant (for all designated States except US): N.V. NUTRICIA [NL/NL]; P.O. Box 1, NL-2700 MA Zoetermeer (NL). (72) Inventors; and (75) Inventors/Applicants (for US only): BIJLSMA, Pieter, Brandt [NL/NL]; Elisabeth Wolffstraat 65e, NL-1043 TS Amsterdam (NL). GROOT, Jacques, Alphons [NL/NL]; Heerenweg 153, NL-1851 KN Heiloo (NL). TIMMERMANS, Johannes, Wilhelmus [NL/NL]; Schoonenburg 188, NL-6714 GE Ede (NL). VAN DER MEULEN, Jan [NL/NL]; De Lipizzaner 33, NL-8252 GS Dronten (NL). KILIAAN, Amanda, Johanne [NL/NL]; Harnjesweg 89, NL-6706 AS Wageningen (NL). (74) Agent: JORRITSMA, Ruurd; Nederlandsch Octrooibureau, Scheveningseweg 82, P.O. Box 29720, NL-2502 LS The Hague (NL).		(81) Designated States: AE, AG, AL, AM, AT, AU, AZ, BA, BB, BG, BR, BY, CA, CH, CN, CR, CU, CZ, DE, DK, DM, DZ, EE, ES, FI, GB, GD, GE, GH, GM, HR, HU, ID, IL, IN, IS, JP, KE, KG, KP, KR, KZ, LC, LK, LR, LS, LT, LU, LV, MA, MD, MG, MK, MN, MW, MX, NO, NZ, PL, PT, RO, RU, SD, SE, SG, SI, SK, SL, TJ, TM, TR, TT, TZ, UA, UG, US, UZ, VN, YU, ZA, ZW, ARIPO patent (GH, GM, KE, LS, MW, SD, SL, SZ, TZ, UG, ZW), Eurasian patent (AM, AZ, BY, KG, KZ, MD, RU, TJ, TM), European patent (AT, BE, CH, CY, DE, DK, ES, FI, FR, GB, GR, IE, IT, LU, MC, NL, PT, SE), OAPI patent (BF, BJ, CF, CG, CI, CM, GA, GN, GW, ML, MR, NE, SN, TD, TG). Published <i>With international search report.</i> <i>In English translation (filed in Dutch).</i>
(54) Title: NUTRITIONAL COMPOSITIONS WHICH CONTAIN SLIGHTLY NEGATIVELY CHARGED, NON-DIGESTIBLE POLYSACCHARIDES AND THE USE THEREOF FOR REDUCING TRANSPORT THROUGH TIGHT JUNCTIONS		
(57) Abstract The present invention relates to a nutritional composition which contains slightly negatively charged non-digestible polysaccharides having a molecular weight of 8kD to 40,000 kD, characterised in that the rise in the viscosity of the composition caused by the polysaccharides is less than 20 mPa.s. The invention also relates to the use of this nutritional composition to reduce the uptake of high molecular weight substances, allergens and microorganisms through the intestinal wall, more particularly to reduce transport of high molecular weight substances, allergens and microorganisms through the tight junctions in the intestines. The nutritional compositions can be used to prevent or to treat allergies, allergic reactions, sepsis and inflammatory processes, such as those which can arise under emotional and physical stress, ischaemia, reperfusion damage during and after operations, following radiation treatment and/or chemotherapy of cancer patients and in the case of inflammatory intestinal diseases, diarrhoea and allergies.		

FOR THE PURPOSES OF INFORMATION ONLY

Codes used to identify States party to the PCT on the front pages of pamphlets publishing international applications under the PCT.

AL	Albania	ES	Spain	LS	Lesotho	SI	Slovenia
AM	Armenia	FI	Finland	LT	Lithuania	SK	Slovakia
AT	Austria	FR	France	LU	Luxembourg	SN	Senegal
AU	Australia	GA	Gabon	LV	Latvia	SZ	Swaziland
AZ	Azerbaijan	GB	United Kingdom	MC	Monaco	TD	Chad
BA	Bosnia and Herzegovina	GE	Georgia	MD	Republic of Moldova	TG	Togo
BB	Barbados	GH	Ghana	MG	Madagascar	TJ	Tajikistan
BE	Belgium	GN	Guinea	MK	The former Yugoslav Republic of Macedonia	TM	Turkmenistan
BF	Burkina Faso	GR	Greece			TR	Turkey
BG	Bulgaria	HU	Hungary	ML	Mali	TT	Trinidad and Tobago
BJ	Benin	IE	Ireland	MN	Mongolia	UA	Ukraine
BR	Brazil	IL	Israel	MR	Mauritania	UG	Uganda
BY	Belarus	IS	Iceland	MW	Malawi	US	United States of America
CA	Canada	IT	Italy	MX	Mexico	UZ	Uzbekistan
CF	Central African Republic	JP	Japan	NE	Niger	VN	Viet Nam
CG	Congo	KE	Kenya	NL	Netherlands	YU	Yugoslavia
CH	Switzerland	KG	Kyrgyzstan	NO	Norway	ZW	Zimbabwe
CI	Côte d'Ivoire	KP	Democratic People's Republic of Korea	NZ	New Zealand		
CM	Cameroon			PL	Poland		
CN	China	KR	Republic of Korea	PT	Portugal		
CU	Cuba	KZ	Kazakstan	RO	Romania		
CZ	Czech Republic	LC	Saint Lucia	RU	Russian Federation		
DE	Germany	LI	Liechtenstein	SD	Sudan		
DK	Denmark	LK	Sri Lanka	SE	Sweden		
EE	Estonia	LR	Liberia	SG	Singapore		

Nutritional compositions which contain slightly negatively charged, non-digestible polysaccharides and use thereof for reducing transport through tight junctions

The present invention relates to nutritional compositions which contain certain
5 classes of non-digestible polysaccharides. These compositions reduce the uptake of high
molecular weight substances, allergens and microorganisms through the intestinal wall. In
particular the present invention relates to reduction of the free transport of such substances
through the tight junctions (TJs) of the intestines, without the transport of low molecular
weight substances, such as nutrients, via the intestinal epithelium being impeded. The
10 compositions can be used to prevent the increased permeability of the intestinal wall, due
to various causes, and the penetration, resulting therefrom, of toxins, antigens and
pathogenic microorganisms present in the lumen.

The structure and function of tight junctions is described, inter alia, in Ann. Rev.
Physiol. 60, 121-160 (1998) and in Ballard T.S. et al., Annu.Rev.Nutr., 1995, 15:35-55.
15 Tight junctions do not form a rigid barrier but play an important role in diffusion through
the intestinal epithelium from lumen to bloodstream and vice versa.

The permeability of the tight junctions is highly regulated and can be disturbed by
disease and certain toxins in the lumen. Regulation takes place from the nervous system,
the hormonal system and the immune system. When tight junctions are opened substances
20 having a high molecular weight, allergens and even microorganisms will pass through the
tight junctions. The translocation of substances having a high molecular weight can, under
certain conditions, give rise to sensitisation of the immune system and result in allergic
reactions on a subsequent exposure. Translocation of pathogenic microorganisms makes a
substantial call on the immune system and, inter alia in periods of reduced resistance, can
25 make persons and animals ill. The same applies, for example, in the case of bacterial
toxins which have been able to pass through the epithelial layer and have been able to
reach the bloodstream.

The invention now relates to nutritional compositions which contain slightly
negatively charged non-digestible polysaccharides having a molecular weight of 8 kD to
30 40,000 kD, characterised in that the rise in the viscosity of the composition caused by the
polysaccharides is less than 20 mPa.s.

In particular the invention relates to the use of these compositions to reduce the
uptake of high molecular weight substances, allergens and microorganisms through the

intestinal wall.

More particularly the invention relates to the use of the abovementioned compositions to reduce transport of high molecular weight substances, allergens and microorganisms through the tight junctions in the intestines.

5 Some of the polysaccharides described above have already been described previously. US 2 813 797 and US 2 834 684 describe the use of carboxymethyl dextran as a thickener, by which means the nutrient acquires certain desirable functional characteristics. This viscosity-raising effect is, as will be described below, undesirable in the case of the present invention.

10 Furthermore, in WO 97/41899 the thickening action of oxidised dextrans is used to make a wound dressing through which the active components are released in a controlled and slow manner to the tissue located under the dressing.

EP 0 772 446 describes the use of a combination of chitosan and dextran sulphate to prevent damaged tissue undesirably adhering to surrounding tissue. EP 0 759 760 discloses
15 the stimulating action of the combination of chitosan and dextran sulphate on the healing of skin wounds.

In EP 0 754 460 it is described that sulphated acid mucopolysaccharides and dextran sulphate can be used for the treatment of diseases associated with inflammation, such as rheumatoid arthritis, ischaemia of the heart or brain, atopic dermatitis, infiltration
20 following organ transplant.

In EP 0 737 072 it is described that sulphated polysaccharides such as dextran sulphate can prevent binding of bacteria to the wall of the respiratory system. WO 96/30027 discloses that sulphated polysaccharides such as carrageenan and dextran sulphate can be used to combat Rotavirus infections. EP 0 719 783 describes the use of
25 non-digestible highly phosphorylated polysaccharides in nutrients to increase calcium absorption.

None of these documents describes the beneficial effect of slightly negatively charged polysaccharides as defined in Claim 1 of this Application. More particularly, it is not described that these polysaccharides have an effect on the tight junctions in the
30 intestines and in the event of disturbance of the permeability of the tight junctions are able to reduce the transport of high molecular weight substances, allergens and microorganisms through the tight junctions into the intestines.

In addition to the significant reduction in the transport of harmful substances and

microorganisms, a significant advantage of the present invention is that the normal transport of useful substances (nutrients) such as glucose, amino acids, dipeptides or trace elements is substantially maintained.

5 According to the invention, non-digestible polysaccharides are understood to be polysaccharides which are not or are barely digested or converted by the human digestive enzymes under the conditions prevailing in the body. It must be pointed out that some of the non-digestible polysaccharides can be fermented by the microorganisms present in the intestines (colon, caecum and part of the ileum). Without wishing to be tied to any theory, it is, however, expected that the effect of the polysaccharides on the paracellular transport
10 does not take place via the fermentation products.

The extent to which the polysaccharides are digested can be determined using the method as described in Minekus, M., Ph.D Thesis, University of Utrecht, 1998, Development and validation of a dynamic model of the gastrointestinal tract, Section 2. The polysaccharides according to the invention are less than 50 % and preferably less than
15 30 % digestible.

Preferably, the polysaccharides according to the invention contain groups which are negatively charged at pH 5.5 - 8, such as carboxyl, sulphate or phosphate, in a quantity of 1 negatively charged group per 3 to 10,000 saccharide units, preferably 1 negatively charged group per 10 to 10,000 saccharide units. Polysaccharides in which the negatively
20 charged groups are carboxyl groups are most preferred.

These polysaccharides can be obtained via a synthesis route or by making use of naturally occurring polysaccharides.

Examples of modified polysaccharides are dextrans into which a negative group has been introduced, for example carboxydextran or carboxymethyldextran. Following or
25 during hydrolysis of a high molecular weight dextran, one or more carboxyl groups can be introduced into the molecule by derivatisation. Derivatisation can, for example, take place by using the Kiliani-Fischer reaction or by carboxymethylation with, for example, chloroacetic acid or by oxidation of, for example, the reducing end of the molecule. Neutral naturally occurring polysaccharides can also be provided with one or more acid
30 groups in this way. Examples of suitable naturally occurring polysaccharides are gluco-mannans; (galacto)mannans, such as guar gum, tara gum, carob gum and locust bean gum; curdlan; agar agar; arabans; (arabino)galactans, tamarind gum, pullulan and (arabino)xylans. Preferably the shortened forms or the hydrolysis products of these

polysaccharides are used. Mixtures of modified polysaccharides can also be used.

Naturally occurring polysaccharides such as gum arabic, some carrageen preparations, chia gum, psyllium, gum tragacanth, ghatti gum, okra gum, some hemicellulose preparations, welan gum, rhamsan gum, gellan gum and certain pectins with
5 a high degree of esterification are suitable as such, but much more preferentially in the hydrolysed form or shortened form obtained in some other way.

When polysaccharides contain too many negatively charged groups, such as, for example, alginates, some carrageen preparations, gellan gum, xanthan gum, karaya gum and many pectin preparations, the suitable quantity of negatively charged groups can be
10 obtained by protecting a suitable fraction of these negatively charged groups, for example by esterification. By this means the specific interaction with the tight junctions can be increased.

Preferably, polysaccharides containing 1 carboxyl group per 10 to 10,000 saccharide units are used. A carboxydextran having a molecular weight of 20 to 2,000 kD and
15 containing 1 carboxyl group per 10 to 10,000 saccharide units is particularly preferred.

The polysaccharides are preferably present in the preparation in a quantity such that the concentration of these polysaccharides in the intestines is 0.1 to 20 g/l, preferably 0.5 to 10 g/l, and most preferentially 1 to 6 g/l. The minimum quantity of the active substance is determined in that a significant decrease in the transport through the tight junctions is
20 observed.

It is not necessary for the polysaccharides to be administered at that location where paracellular transport is disturbed. The presence of the active component at a location somewhere in the intestines between the stomach and the affected location is adequate.

Some of the polysaccharides used according to the invention have a viscosity-raising
25 effect, which could prevent the absorption of nutritional components. The preparation must have a composition such that the normal transcellular transport is not impeded.

More particularly, the nutritional composition according to the invention has a viscosity of less than 100 mPa.s, preferably less than 40 and even more preferentially less than 30 mPa.s. For the present invention it is important, in particular, that the
30 polysaccharides, irrespective of the other constituents of the composition, have only a slight viscosity-raising effect. The viscosity-raising effect of the active polysaccharides in the composition must be less than 20 and preferably less than 10 mPa.s and can be, for example, 3 mPa.s. The viscosity of the product is thus in the main caused by components

in the product other than the polysaccharides.

The viscosity is determined by means of a Carri-med at a shear rate of 100 per second and at 20 °C.

5 In the case of dry products the viscosity limits described above apply after reconstitution of the product.

In general, therefore, the type of polysaccharide (structure and molecular weight) and the concentration thereof will be so chosen that an optimum combination of effectiveness and viscosity is obtained. Not only molecular size, but also degree of branching and degree of loading determine activity, viscosity and/or fermentation
10 behaviour.

The polysaccharides according to the invention prevent the free transport of high molecular weight substances, allergens and microorganisms through the tight junctions of the intestinal wall. In this context high molecular weight substances are understood to be the substances which under normal conditions are not able to pass through the tight
15 junctions and for which a toxic or allergenic action can be assumed. These substances will in general have a molecular size of more than 4,000 Dalton. Antigens, substances which activate the immune system, are in general peptides, which may or may not be glycosidated, often with a molecular weight in excess of 10,000 Dalton. Allergens are antigens which give rise to an allergic reaction, which is usually mediated via
20 immunoglobulin E.

In this context microorganisms are understood to be in particular microorganisms which occur in the intestinal lumen. Thus, for example, under certain conditions overgrowth of microorganisms in the small intestine can take place, as a result of which tight junctions are exposed to these microorganisms to an increased extent.

25 According to another aspect of the invention, foods or preparations are proposed which contain these slightly negatively charged, non-digestible polysaccharides. These foods can be:

- complete foods;
- food supplements;
- 30 - health-promoting preparations; and
- tube feeds.

The compositions according to the invention can be used to prevent or to treat allergies, allergic reactions, sepsis and inflammatory processes, such as those which can

arise under emotional and physical stress, ischaemia, reperfusion damage during and after operations, following radiation treatment and/or chemotherapy of cancer patients and in the case of inflammatory intestinal diseases, diarrhoea and allergies.

5 The complete foods and food supplements described above can, in particular, be used for the treatment or prevention of inflammatory intestinal diseases, such as colitis ulcerosa, inflammatory bowel disease and Crohn's disease. Specific other constituents which can be incorporated in such foods and supplements are growth hormones, glutamines, n-3 LCPUFA's and the requisite contents of macro- and micro-ingredients.

10 Furthermore, the foods according to the invention can be used before and after operations. Specifically, ischaemia and reperfusion damage to the intestines often occurs during operations, as a result of which the tight junctions open. Introducing the polysaccharides according to the invention into the intestines before and after the operation could prevent uncontrolled paracellular transport. The administration of these polysaccharides can also be beneficial following chemotherapy.

15 In the case of diarrhoea a number of patho-morphological changes can also occur which are associated with increased permeability of the tight junctions. These changes can occur both in the case of travellers' diarrhoea and after diarrhoea following treatment with antibiotics and diarrhoea which follows after food poisoning. The complete foods and food supplements according to the invention can be used to counteract the adverse consequences of this increased permeability.

20 The tight junctions can also open during stress, both of a physical nature (for example endurance sports) and of an emotional nature, as a result of which bacterial translocation takes place. An example of emotional stress under which this takes place is the stress which occurs during the transport of pigs to the slaughterhouse. Contamination of the meat can occur as a result. Another example is the stress which occurs when weaning piglets. The polysaccharides can be administered before, during or after stress.

25 With the aid of the polysaccharides according to the invention it is also possible to prepare preparations which are suitable for patients who have a food allergy, such as an allergy to cow's milk or to gluten. The increase in the permeability as a result of exposure to the allergen can be prevented. These preparations are formulated such that the said allergens are not present therein.

The invention is explained on the basis of the following examples and with reference

to the appended figures, in which

Figure 1 shows the Ussing chamber used in the examples;

Figure 2 shows a graphic by means of which the effect of the present invention is demonstrated; and

5 Figure 3 shows the test set-up used in the examples.

Examples

I. Methods for the preparation of an active compound

10

Example 1

20 20 g slightly hydrolysed guar gum is dissolved in 300 ml dimethylformamide. 50 g pyridine sulphur trioxide is added to this solution, after which the temperature is kept at 80 to 140 °C for 6 hours. The dimethylformamide is removed under reduced pressure, after
15 which the product is dissolved in 300 ml water. After washing three times with 200 ml dichloromethane, the aqueous phase is dialysed and freeze-dried.

Example 2

20 Carboxydextran is obtained by dissolving 1.1 kg dextran (147 kD) in 2.3 l water and adding 17.4 g NH₄Cl and 4.8 g KCN. After stirring for 40 hours at 55 °C, 7 ml HCOOH is added and then N₂ gas is passed through vigorously for 3 hours. After adding a further 7 ml HCOOH, followed by freeze-drying, this yields dry cyanodextran. 1.1 kg of the latter is dissolved in 2 l water, after which 14.6 g Na₂CO₃ is added. After stirring for 136 hours at 60 °C whilst passing N₂ gas through vigorously and then freeze-drying, the desired
25 carboxydextran is obtained.

Example 3

30 Carboxymethyldextran having a molecular weight of 147,000 Dalton is obtained by dissolving 100 g dextran (147 kD) in 500 ml water and adding 40 g NaOH and 12 g chloroacetic acid to this solution. The mixture is stirred for 2 hours at 60 °C, after which 5/6 of the mixture is worked up. After precipitating three times from water by means of ethanol, the product is dissolved in water, dialysed and freeze-dried.

Example 4

Guar phosphate is obtained by dissolving 20 g slightly hydrolysed guar gum in 500 ml water together with 20 g NaH_2PO_4 and 30 g Na_2HPO_4 . A phosphorilated guar with a $T_s < 0.1$ is obtained by this means. This is then dried at 60 °C, after which it is kept at 5 140 °C for 2 hours. It is then dialysed and then dried.

II Examples of products

Examples of compositions of various types of products in which the active component is carboxydextran are given below. It is in line with the invention that the other 10 polysaccharides described in this application, as well as mixtures thereof, can also be used.

The various types of product can be complete enteral food, for use by the patient him/herself or for use as a tube feed. The product can be either in liquid form or in powder form which is ready for use after dissolving. The active components can also be used as an ingredient in another food (for example bread) or in food supplements, such as a bar, a 15 dairy product, such as yoghurt, or a powder in the form of a sachet.

Example 5

Ready-to-feed, liquid, complete food for use before or after operations. Per 100 ml, the product has the following composition:

20	Protein:	7.0 g
	Fat:	4.0 g
	Carbohydrates:	21 g
	Carboxydextran according to Example 2:	0.2 g

Minerals are added in an amount of 1/15 of the recommended daily allowance 25 (= RDA) per 100 ml of the product. Trace elements and vitamins are added in somewhat higher amounts, i.e. 2/15 RDA. The product is formulated such that 1,500 ml has to be consumed by the patient.

Example 6

30 Complete food for administering by tube to persons suffering from inflammatory bowel disease. The product contains the following, per 100 ml:

Protein based on casein: 7.0 g

Fat based on vegetable oils and 10 % fish oil and 20 % MCT; the linoleic acid

content is 20 % and the alpha-linolenic acid content 4.5 %

Premixes with the customary forms of trace elements, vitamins and minerals Na, K, Ca, Mg, P, Zn, Fe, Mn, Cu, Vit. B1, B2, niacin, A, D, K, B6, B12, pantothenic acid, folic acid.

5 Carboxydextran according to Example 2: 0.6 g

Example 7

Food supplement for patients suffering from food intolerance or allergy.

Yoghurt based on soya milk. The yoghurt contains the following per 100 ml:

10 Protein 4.0 g, fat 3.9 g, carbohydrates 12.3 g and 0.1 RDA of vitamins and trace elements.

Na = 80; K = 135; Cl = 125; Ca = 50; P = 50; Mg = 20 mg

Carboxydextran according to Example 2: 0.5 g

15 Example 8

Energy drink for athletes.

The liquid contains the following per 100 ml

Carbohydrates: 7.0 g

Glucose: 0.2 g

20 Fructose: 1.8 g

Lactose: 0.4 g

Saccharose 1.7 g

Polysaccharides: 2.5 g

Organic acids: 0.4 g

25 Minerals:

Na: 37 mg

K: 17 mg

Cl: 58 mg

Ca 8 mg

30 Mg: 1 mg

Vitamin C: 15 mg

Carboxydextran according to Example 2 = 0.1 g

Example 9

Premix for use in pig or piglet feed.

A/Premix consisting of 90 % maize flour and 10 % 150 kD carboxydextran.

5 B/Premix consisting of a suitable premix of vitamins, trace elements and minerals and 10 % carboxydextran prepared in accordance with Example 2.

Premix A, B or mixtures thereof can be used in the preparation of pig feeds. These can be special feeds for use when pigs are loaded for transport or have to be allocated different positions in the sty or if they have a period of reduced resistance.

10 The premixes can also be used in a piglet feed for use after weaning, as an additive to or instead of the premixes which are already known for use in piglet feed.

III Effect on transport via the tight junctions of the intestines

Use was made of a model set-up to determine the effect of the polysaccharides used.

15 A rat is brought under narcosis. The stomach wall is then opened and a section of the ileum is tied off. The intestinal tissue is removed and muscle layers stripped from it. The preparation thus obtained is then stretched between two compartments through which oxygenated solutions are flowing (Figure 1). The preparation was treated either with buffer (control or zero value) or carbachol in buffer to open the tight junctions (100 % permeability) or with the combination of carbachol and a certain concentration of
20 polysaccharide in buffer. As a measure of the permeability the transport of HRP (horseradish peroxidase) over the preparation is measured in accordance with known methods.

It is shown in Figure 2 that carboxydextrans lower the rise in the permeability of the intestines as a consequence of carbachol, in contrast to neutral dextrans of comparable
25 molecular weight.

Suction biopsies of the duodenum were taken from two children suffering from microvillus inclusion disease. In the Ussing chamber these preparations showed a permeability for HRP that was four times higher than the normal value. After adding 4.2 g
30 70 kD carboxydextran to the luminal compartment in the Ussing chamber the permeability was reduced to the normal level. No further HRP could be detected in the paracellular spaces or tight junctions by means of electron microscopy.

Claims

1. Nutritional composition which contains slightly negatively charged non-digestible polysaccharides having a molecular weight of 8 kD to 40,000 kD, characterised in that the
5 rise in the viscosity of the composition caused by the polysaccharides is less than 20 mPa.s.

2. Nutritional composition according to Claim 1, wherein the polysaccharides contain groups which are negatively charged at pH 5.5 - 8 in a quantity of 1 negatively
10 charged group per 3 to 10,000 saccharide units, preferably 1 negatively charged group per 10 to 10,000 saccharide units.

3. Nutritional composition according to Claim 1 or 2, wherein the negatively charged
15 groups are carboxyl, sulphate or phosphate groups, preferably carboxyl groups.

4. Nutritional composition according to one of the preceding claims, wherein the polysaccharides have been obtained by introduction of an acid group into dextrans, slightly hydrolysed, neutral galactomannans, neutral glucomannans or arabinoxylans.

20 5. Nutritional composition according to one of the preceding claims, wherein the polysaccharides are carboxydextrans having a molecular weight of 20 to 2,000 kD and containing 1 carboxyl group per 10 to 10,000 saccharide units.

25 6. Nutritional composition according to one of the preceding claims, wherein the polysaccharides are present in the composition in an amount such that the concentration of these polysaccharides in the intestines is 0.1 to 20 g/l, preferably 0.5 to 10 g/l, most preferentially 1 to 6 g/l.

30 7. Nutritional composition according to one of the preceding claims in the form of a complete food.

8. Nutritional composition according to one of the preceding claims in the form of a food supplement.

9. Use of a nutritional composition according to one of the preceding claims to reduce the uptake of high molecular weight substances, allergens and microorganisms through the intestinal wall.

5

10. Use according to Claim 9, to reduce transport of high molecular weight substances, allergens and microorganisms through the tight junctions in the intestines.

10 11. Use according to Claim 9 or 10, to prevent or to treat allergies, allergic reactions, sepsis and inflammatory processes, such as those which can arise under emotional and physical stress, ischaemia, reperfusion damage during and after operations, following radiation treatment and/or chemotherapy of cancer patients and in the case of inflammatory intestinal diseases, diarrhoea and allergies.

Fig 1

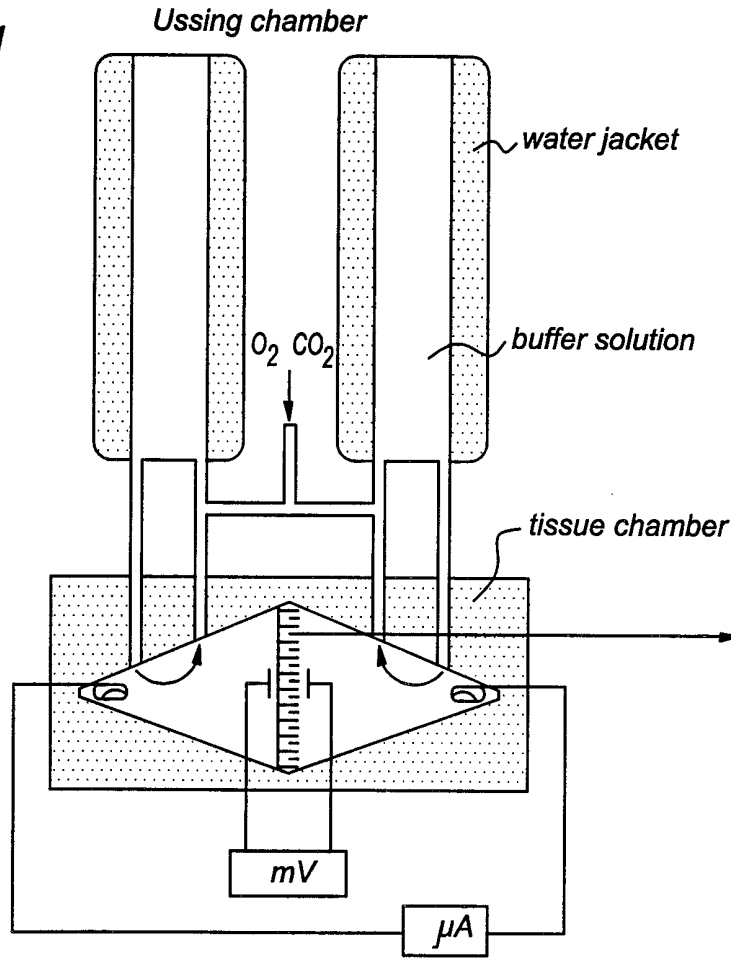
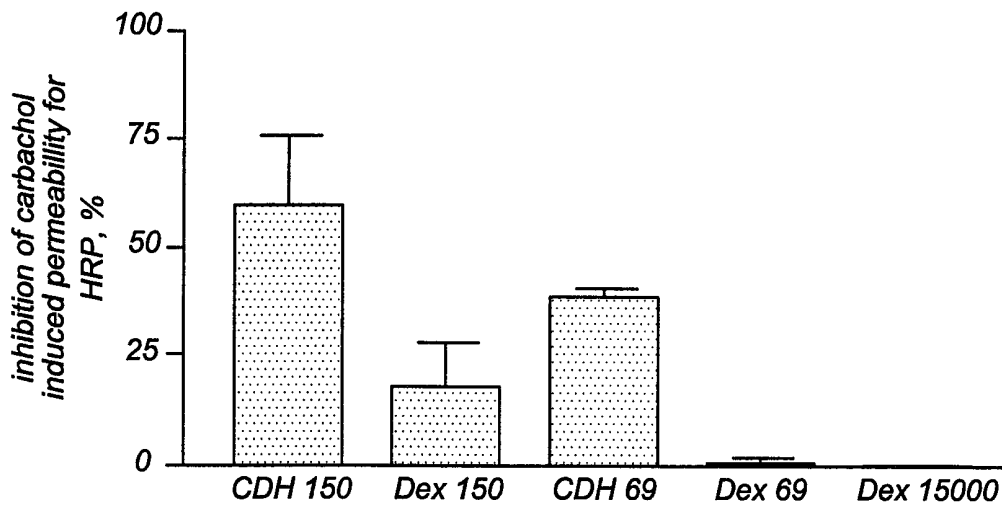

Fig 2



INTERNATIONAL SEARCH REPORT

International Application No

PCT/NL 00/00187

A. CLASSIFICATION OF SUBJECT MATTER
 IPC 7 A23L1/308 A61K31/715 A23L1/054 A23L1/0526

According to International Patent Classification (IPC) or to both national classification and IPC

B. FIELDS SEARCHED

Minimum documentation searched (classification system followed by classification symbols)
 IPC 7 A23L A61K

Documentation searched other than minimum documentation to the extent that such documents are included in the fields searched

Electronic data base consulted during the international search (name of data base and, where practical, search terms used)

WPI Data, PAJ, EPO-Internal, FSTA, CHEM ABS Data

C. DOCUMENTS CONSIDERED TO BE RELEVANT

Category *	Citation of document, with indication, where appropriate, of the relevant passages	Relevant to claim No.
A	US 5 616 570 A (LANGE III LOUIS G ET AL) 1 April 1997 (1997-04-01) column 6, line 16 -column 9, line 11 ---	1-8
A	US 5 260 279 A (GREENBERG NORMAN A) 9 November 1993 (1993-11-09) column 2, line 13 - line 66 ---	1-8
A	US 2 813 797 A (H.A. TOULMIN) 19 November 1957 (1957-11-19) cited in the application column 1, line 67 -column 2, line 38 ---	1-8
A	EP 0 153 013 A (FISONS PLC) 28 August 1985 (1985-08-28) page 2, line 15 -page 7, line 22 ---	1-8
	-/--	

Further documents are listed in the continuation of box C.

Patent family members are listed in annex.

* Special categories of cited documents :

- "A" document defining the general state of the art which is not considered to be of particular relevance
- "E" earlier document but published on or after the international filing date
- "L" document which may throw doubts on priority claim(s) or which is cited to establish the publication date of another citation or other special reason (as specified)
- "O" document referring to an oral disclosure, use, exhibition or other means
- "P" document published prior to the international filing date but later than the priority date claimed

- "T" later document published after the international filing date or priority date and not in conflict with the application but cited to understand the principle or theory underlying the invention
- "X" document of particular relevance; the claimed invention cannot be considered novel or cannot be considered to involve an inventive step when the document is taken alone
- "Y" document of particular relevance; the claimed invention cannot be considered to involve an inventive step when the document is combined with one or more other such documents, such combination being obvious to a person skilled in the art.
- "&" document member of the same patent family

Date of the actual completion of the international search

19 June 2000

Date of mailing of the international search report

12.07.00

Name and mailing address of the ISA

European Patent Office, P.B. 5818 Patentlaan 2
 NL - 2280 HV Rijswijk
 Tel. (+31-70) 340-2040, Tx. 31 651 epo nl,
 Fax: (+31-70) 340-3016

Authorized officer

Vuillamy, V

INTERNATIONAL SEARCH REPORT

International Application No
PCT/NL 00/00187

C.(Continuation) DOCUMENTS CONSIDERED TO BE RELEVANT

Category °	Citation of document, with indication, where appropriate, of the relevant passages	Relevant to claim No.
A	EP 0 648 495 A (HERCULES INC) 19 April 1995 (1995-04-19) page 6, line 51 -page 7, line 27 -----	1-8

INTERNATIONAL SEARCH REPORT

International application No.
PCT/NL 00/00187

Box I Observations where certain claims were found unsearchable (Continuation of item 1 of first sheet)

This International Search Report has not been established in respect of certain claims under Article 17(2)(a) for the following reasons:

1. Claims Nos.:
because they relate to subject matter not required to be searched by this Authority, namely:

2. Claims Nos.: 1-4 6-11
because they relate to parts of the International Application that do not comply with the prescribed requirements to such an extent that no meaningful International Search can be carried out, specifically:
see FURTHER INFORMATION sheet PCT/ISA/210

3. Claims Nos.:
because they are dependent claims and are not drafted in accordance with the second and third sentences of Rule 6.4(a).

Box II Observations where unity of invention is lacking (Continuation of item 2 of first sheet)

This International Searching Authority found multiple inventions in this international application, as follows:

1. As all required additional search fees were timely paid by the applicant, this International Search Report covers all searchable claims.

2. As all searchable claims could be searched without effort justifying an additional fee, this Authority did not invite payment of any additional fee.

3. As only some of the required additional search fees were timely paid by the applicant, this International Search Report covers only those claims for which fees were paid, specifically claims Nos.:

4. No required additional search fees were timely paid by the applicant. Consequently, this International Search Report is restricted to the invention first mentioned in the claims; it is covered by claims Nos.:

Remark on Protest

- The additional search fees were accompanied by the applicant's protest.
- No protest accompanied the payment of additional search fees.

INTERNATIONAL SEARCH REPORT

International Application No. PCT/NL 00 00187

FURTHER INFORMATION CONTINUED FROM PCT/ISA/ 210

Continuation of Box I.2

Claims Nos.: 1-4 6-11

1) Present claims 11-4, 6-11 relate to a product defined by reference to a desirable characteristic or property, namely:

'the rise in the viscosity of the composition caused by the polysaccharides is less than 20 mPa.s'

The description teaches (cf. p.6, 1.8-10) that 'not only molecular size, but also degree of branching and degree of loading determine activity, viscosity and/or fermentation behaviour'.

The claims cover all products having this characteristic or property, whereas the application provides support within the meaning of Article 6 PCT and disclosure within the meaning of Article 5 PCT for only a very limited number of such products. In the present case, the claims so lack support, and the application so lacks disclosure, that a meaningful search over the whole of the claimed scope is impossible. Independent of the above reasoning, the claims also lack clarity (Article 6 PCT). An attempt is made to define the product by reference to a result to be achieved. Again, this lack of clarity in the present case is such as to render a meaningful search over the whole of the claimed scope impossible. Consequently, the search has been carried out for those parts of the claims which appear to be clear, supported and disclosed, namely those parts relating to the products prepared in examples 1-9 and closely related homologous products.

2) Present claims 1-4, 6-11 relate to an extremely large number of possible products. Support within the meaning of Article 6 PCT and disclosure within the meaning of Article 5 PCT is to be found, however, for only a very small proportion of the products claimed. In the present case, the claims so lack support, and the application so lacks disclosure, that a meaningful search over the whole of the claimed scope is impossible. Consequently, the search has been carried out for those parts of the claims which appear to be supported and disclosed, namely those parts relating to the products prepared in examples 1-9 and closely related homologous products.

The applicant's attention is drawn to the fact that claims, or parts of claims, relating to inventions in respect of which no international search report has been established need not be the subject of an international preliminary examination (Rule 66.1(e) PCT). The applicant is advised that the EPO policy when acting as an International Preliminary Examining Authority is normally not to carry out a preliminary examination on matter which has not been searched. This is the case irrespective of whether or not the claims are amended following receipt of the search report or during any Chapter II procedure.

INTERNATIONAL SEARCH REPORT

Information on patent family members

International Application No

PCT/NL 00/00187

Patent document cited in search report	A	Publication date	Patent family member(s)	Publication date
US 5616570	A	01-04-1997	NONE	
<hr style="border-top: 1px dashed black;"/>				
US 5260279	A	09-11-1993	AT 120930 T	15-04-1995
			AU 651626 B	28-07-1994
			AU 8603491 A	30-04-1992
			CA 2053933 A	25-04-1992
			DE 69108846 D	18-05-1995
			DE 69108846 T	12-10-1995
			DK 483070 T	17-07-1995
			EP 0483070 A	29-04-1992
			ES 2073154 T	01-08-1995
			JP 4282316 A	07-10-1992
<hr style="border-top: 1px dashed black;"/>				
US 2813797	A	19-11-1957	NONE	
<hr style="border-top: 1px dashed black;"/>				
EP 0153013	A	28-08-1985	AT 56148 T	15-09-1990
			AU 571641 B	21-04-1988
			AU 3819385 A	08-08-1985
			DE 3579471 D	11-10-1990
			DK 39685 A	02-08-1985
			JP 60188403 A	25-09-1985
<hr style="border-top: 1px dashed black;"/>				
EP 0648495	A	19-04-1995	AT 188380 T	15-01-2000
			AU 675542 B	06-02-1997
			AU 6750294 A	27-01-1995
			BR 9402851 A	13-06-1995
			CA 2128160 A	17-01-1995
			CN 1104890 A	12-07-1995
			CZ 9401702 A	18-10-1995
			DE 69422465 D	10-02-2000
			DE 69422465 T	15-06-2000
			ES 2140482 T	01-03-2000
			FI 943296 A	17-01-1995
			HU 75240 A	28-05-1997
			JP 7090002 A	04-04-1995
			MX 9405307 A	31-01-1995
			NO 942620 A	17-01-1995
			NZ 260933 A	26-07-1996
			PL 304319 A	23-01-1995
<hr style="border-top: 1px dashed black;"/>				