

(No Model.)

G. L. ADAMS.  
CAR BRAKE.

No. 326,191.

Patented Sept. 15, 1885.

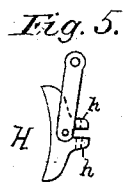
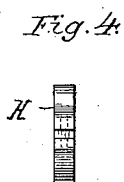
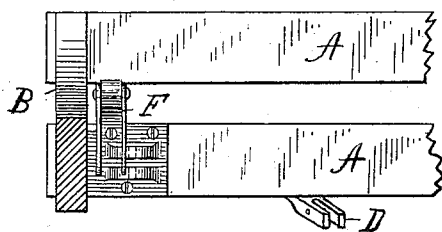
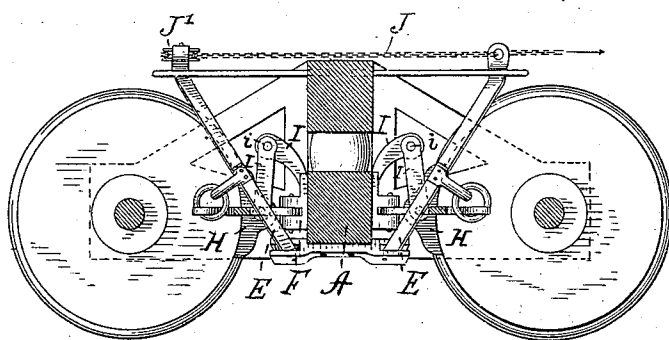
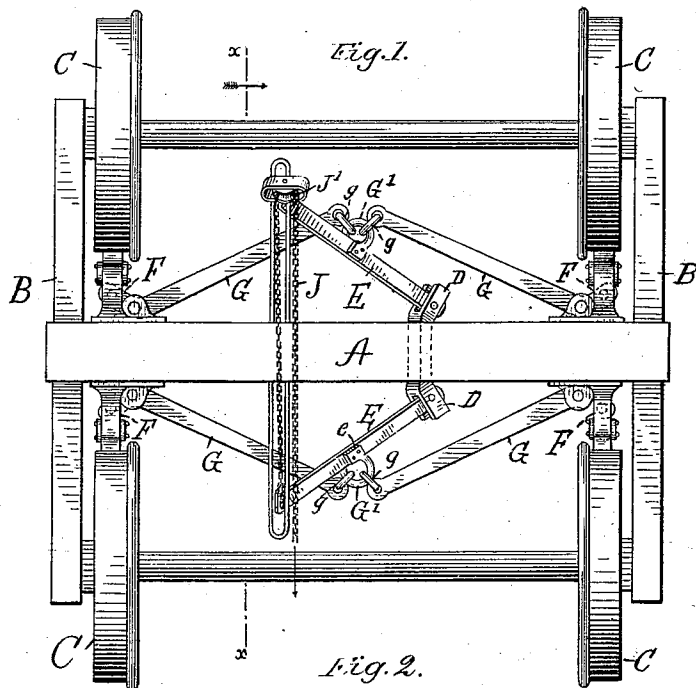

Witnesses:  
Ernest Abshagen  
Wm. Stone

Inventor:  
Gilbert Lloyd Adams,  
By  
Alexander & Herr,  
his Attorneys:

# UNITED STATES PATENT OFFICE.

GILBERT LLOYD ADAMS, OF ALTOONA, PENNSYLVANIA, ASSIGNOR OF ONE-THIRD TO ALEXANDER & HERR.

## CAR-BRAKE.

SPECIFICATION forming part of Letters Patent No. 326,191, dated September 15, 1885.

Application filed October 22, 1884. (No model.)

*To all whom it may concern:*

Be it known that I, GILBERT LLOYD ADAMS, of Altoona, in the county of Blair and State of Pennsylvania, have invented a new and useful  
5 Improvement in Car-Brakes, especially designed for use on freight-cars; and I hereby declare the following to be a full and clear description thereof.

This invention relates to the construction and  
10 arrangement of the levers for operating the brake and the general mechanism and construction of the parts connected therewith.

The invention will be readily understood by reference to the accompanying drawings, of  
15 which—

Figure 1 is a plan view of a car-truck fitted with the improved brake appliances. Fig. 2 is a longitudinal sectional elevation taken on the line *x x* of Fig. 1, just at one side of the  
20 central pivot block or fulcrum, which is attached to the central spring-beam of the truck. Fig. 3 is a front elevation of the spring-beam and the brake devices, the wheels and other parts of the truck being removed for the sake  
25 of perspicuity. In this view are clearly shown the fulcrum-plates of both primary and secondary levers, and also the vertical arms to which the brake-shoes are attached. The brake-shoes are removed in this figure, as well  
30 as parts of the truck. Fig. 4 is an elevation of the brake-shoe detached from the other parts. Fig. 5 is a detailed view showing a side elevation of the brake-shoe and the vertical arm to which the shoe is hung, the two  
35 parts coupled together as in use.

The truck, as is usual, has a central bolster or spring-plank, A, made either in one or two parts, with end frames, B, in which the axles of the wheels C have their supporting or bearing  
40 boxes.

To the central part of the beam A, near its bottom edge, if there is only one beam, or, if there are two, near the bottom edge of the lower  
45 beam, is secured a fulcrum-block, D, one on each side of the beam, to which fulcrum-blocks are pivoted the lower ends of the two actuating-levers E. There are also secured to each side of the beam A, just inside of the wheels, two vertical arm-pieces, F, one near each end

of the beam. These arm-pieces provide ful- 50  
crum-blocks for the secondary levers G, as shown in Figs. 1 and 3, and also, by means of their upwardly-extending arms, attachment-  
supports for the brake-shoes, as shown best in Fig. 5. The brake-shoes H are hung to the  
55 upper ends of the arm-pieces F either by links I, as shown in Fig. 2, or, in lieu of them, an arm or connection piece cast solid with the brake-shoe. In either case the brake-shoe is allowed a swinging or pendulous movement on  
60 the coupling pin or pivot *i*, on which it is suspended at the top end of the arm F. The rear or outside of each brake-shoe has a pair of lugs, *h*, extending rearwardly, and a small slot  
65 formed between these two lugs forms the seat of the secondary lever G. The free or moving ends of the levers G on each side of the beam A are coupled in an assembling-clevis, G', by a pivot or coupling pin, *g*, and a slot in the  
70 other side of the said assembling clevis-piece receives the actuating-lever E, which is connected to the said clevis-piece by an assembling-bolt, *e*.

As is clearly shown in the drawings, the actuating-lever E, coupled with the secondary levers G, form a set of compound levers for applying pressure to the brake-shoes. There is one of these sets of compound levers on each side of the central beam, A, as is clearly shown  
80 in Fig. 1. The two sets of compound levers are actuated simultaneously, so as to apply all of the brakes of a single truck to the wheels of that truck at the same moment. For this purpose an operating cord, chain, or rope, (preferably of wire,) J, is attached to the top end of  
85 one of the levers E, and is thence taken over to and run around a sheave, J', attached to the top end of the other actuating-lever, and thence it is conducted back to the operating brake-rod, (not shown,) and by tightening up the said  
90 cord or chain J the levers E are both drawn together, and thereby move the coupled secondary levers G, so as to apply all of the brakes simultaneously.

The fulcrum-pieces D and the clevis-pieces 95  
G' have several holes formed through them for the accommodation of the assembling pins or bolts to several different positions, so as to form

an adjustment or take-up for the parts as they become worn by use.

Having thus described my invention, what I claim as new, and desire to secure by Letters Patent, is—

1. The brake-levers G, fulcrumed to the central bolster or spring-beam, A, and arranged to have their shorter arms press the brake-shoes H against the wheels, and their longer arms actuated by primary levers E, which are also fulcrumed to the central bolster or spring-beam, A, and operated by a single chain or cord, J, which is operated so as to draw together the free or moving ends of the primary levers E, substantially as shown and set forth.

2. The levers E and G, respectively fulcrumed to the central beam, A, and the ends of the levers G coupled by links or clevises G'

to the central part of the levers E, so that when pressure is applied to the said levers the fulcrum-strains are all pressing against the central beam, A, and with equal force to each side of it, substantially as shown and set forth. 20

3. The hanger-pieces F, secured to the sides of the beam A near its ends, and constructed to form fulcrum-blocks for the levers G, and also holders or arms for the brake-shoes, with which and with the levers G they are combined, as described and set forth. 25

In witness whereof I have hereunto set my hand this 26th day of September, 1884. 30

GILBERT LLOYD ADAMS.

In presence of—

WILLIAM STOKE,  
MILTON ALEXANDER.