

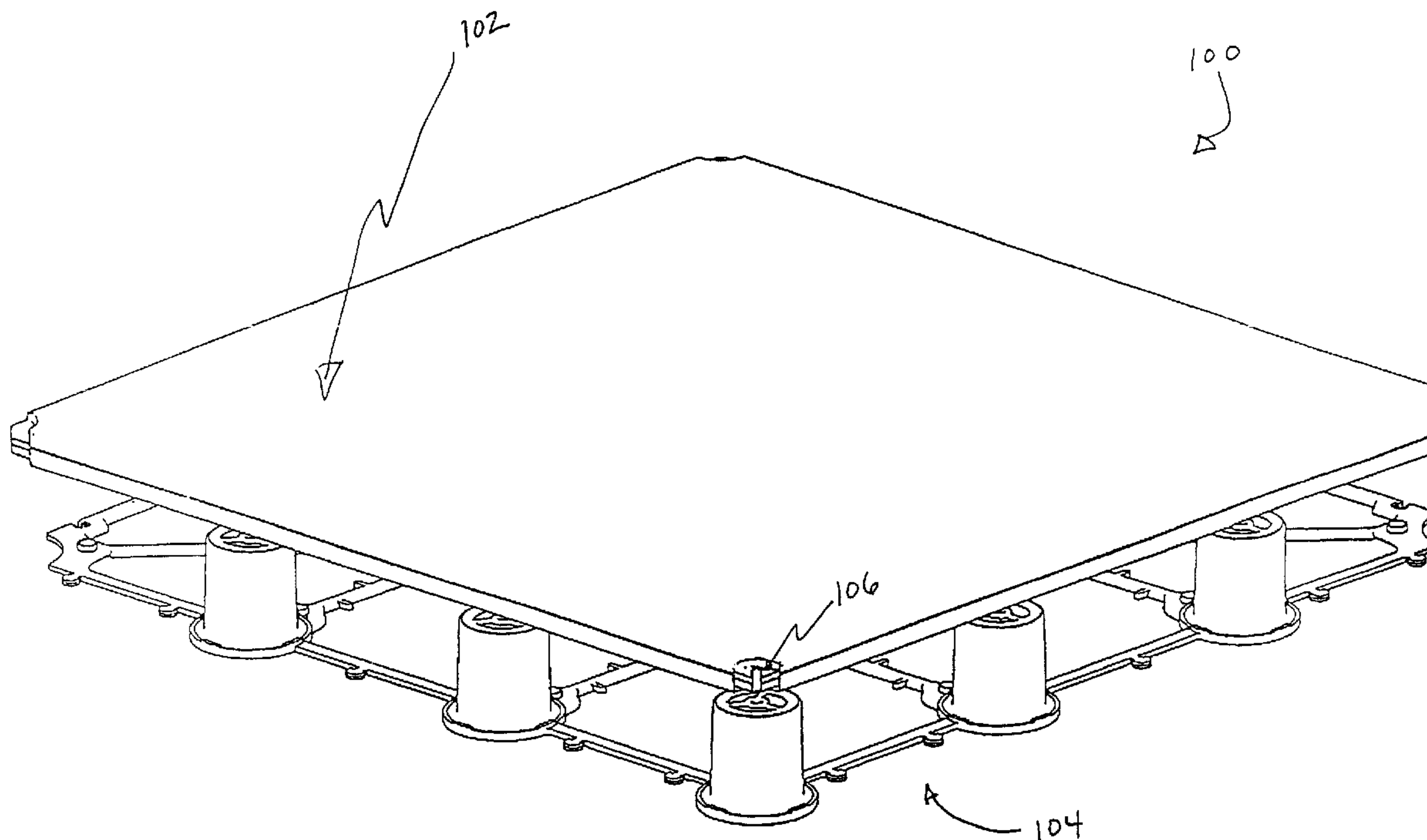

(22) Date de dépôt/Filing Date: 2000/04/06
(41) Mise à la disp. pub./Open to Public Insp.: 2001/09/06
(30) Priorité/Priority: 2000/03/06 (UNKNOWN) US

(51) Cl.Int.⁷/Int.Cl.⁷ E04F 15/024, E04B 5/48
(71) Demandeur/Applicant:
SMED INTERNATIONAL, INC., CA
(72) Inventeurs/Inventors:
MARSHALL, DALE, CA;
SPAVOR, PAUL, CA
(74) Agent: GOWLING LAFLEUR HENDERSON LLP

(54) Titre : SYSTEME DE PLANCHER TECHNIQUE ET DIRECTIVES D'INSTALLATION DE CE SYSTEME
(54) Title: RAISED FLOOR SYSTEM AND METHOD OF INSTALLING SAME



(57) Abrégé/Abstract:

A raised floor system for installation over a base floor that allows ready access to the space created thereunder. Raised floor panels are supported above the base floor by and secured to base floor web tile assemblies that interconnect one to another. Each base floor web tile assembly includes a plurality of hollow metal cylinders with a lower portion to which a plastic base floor web tile is over-molded. The base floor web tile has adhesion pads with apertures which allow adhesive to be injected below the tile from above. The adhesive is used to affix the interconnected base floor web tile assemblies to the base floor. Further, an upper surface of each metal cylinder has over-molded thereto a plastic floor panel support boss. The floor panel support boss engages with a threaded panel fastener to secure a raised floor panel to a floor panel support of a base floor web tile assembly. Services such as telephone, electricity and computer cables may be installed in the space under the raised floor panels.

Raised Floor System and Method of Installing Same

Abstract

5 A raised floor system for installation over a base floor that allows ready
access to the space created thereunder. Raised floor panels are supported above
the base floor by and secured to base floor web tile assemblies that interconnect
one to another. Each base floor web tile assembly includes a plurality of hollow
metal cylinders with a lower portion to which a plastic base floor web tile is over-
molded. The base floor web tile has adhesion pads with apertures which allow
adhesive to be injected below the tile from above. The adhesive is used to affix
10 the interconnected base floor web tile assemblies to the base floor. Further, an
upper surface of each metal cylinder has over-molded thereto a plastic floor panel
support boss. The floor panel support boss engages with a threaded panel fastener
to secure a raised floor panel to a floor panel support of a base floor web tile
assembly. Services such as telephone, electricity and computer cables may be
15 installed in the space under the raised floor panels.

Raised Floor System and Method of Installing Same

Inventors: Dale Marshall
Paul Spavor

5

Background of the Invention

Field of the Invention

This invention pertains to an improved design of a raised floor system that is also known as: an elevated floor, an access floor, a false floor, a pedestal floor, a cellular floor or a computer floor system.

10

Related Art

15

A raised floor system is used where it is desirable to maintain ready access below the floor surface to cables, wiring, ducting and other building services. Access floor assemblies of the general class of the present invention are well known in the prior art. Such flooring has been manufactured for many years and is used extensively in computer and control rooms, and more recently in general office areas.

20

A raised floor system generally consists of a plurality of floor panels that are supported a short distance above a base floor by support members. The floor panels form a raised floor enclosing a space between the raised floor surface and the base floor. The space can be used for the distribution of air, ductwork, electrical wiring, communication wiring and computer cables, as well as many other services. Each panel is individually removable for easy access to the services below and to allow quick, low-cost relocation of service outlets.

25

Some prior raised floor designs include pedestals with stringers therebetween on which floor panels are supported. The stringers serve to make the floor more rigid, but create a problem in laying additional wiring or ductwork since both the floor panels and the stringers need to be removed to allow access to the space.

Floor panels in much of the prior designs are maintained in position by simple gravity placement, or by being bolted to pedestals or to a combination pedestal and stringer network. As such, in many of these prior designs the floor panels settled after time which resulted in an uneven floor surface prone to rocking when loads were applied to the floor surface. By adjusting each pedestal, corrections could be made to account for the settling of the floor panels but this process is often time consuming and disruptive of office routine, as well as expensive.

To address this concern, in U.S. Patent No. 4,438,610 to Fifer, free-standing pedestals are used to support interlocking floor panels above the base floor. During installation, pedestals are arranged along the base floor in a predetermined array and then floor panels are interlocked and secured to the pedestals. Thus, the precise location of the pedestals is only determined once the floor panels are installed. Adhesive is then used to secure the pedestals to the base floor.

Although the floor surface of the raised floor system described in U.S. Patent No. 4,438,610 is sturdy and resists settling/deformation, the design and process of installing a raised floor according to this design is tedious and time consuming due to the careful measuring and layout required to assure pedestal placement at each corner of a floor panel plus the subsequent trial and error involved in getting the pedestals correctly positioned during actual installation. In addition, each pedestal must then be individually secured to the base floor and leveled.

To address the problems associated with pedestals and/or stringers, U.S. Patent No. 4,905,437 to Heather suggests a plastic floor support module of unitary construction. The module comprises a plurality of support props extending upward from an integral frame arrangement with integral connection means for joining the module to a support prop of an adjacent floor support module. Support props are formed to accept a threaded fastener by which the corner of a floor panel may be secured and/or to support the underside of the floor

panel. This configuration minimizes the necessity of leveling the floor panels and provides better support for the floor panels since each floor panel rests on support props at its corners and at various points about its interior area.

5 However, installation and repair of the flooring system disclosed in U.S. Patent No. 4,905,437 is difficult due to the unitary nature of the floor support module. The floor support modules interconnect one to another forming an array to which the floor panels are secured. There is not a one-to-one relationship between any given floor support module and floor panel. Thus, positioning of floor panels is dependent on the location of the nearest support prop to each of its
10 four corners. Often times, a floor panel will not align with a support prop at each corner. This results from a variety of causes, including dimensional build which can occur as a consequence of incidental stretching of the unitary floor support module during installation, *i.e.*, stretching that occurs when modules are laid and connected on the base floor and then lifted so that adhesive may be applied to the
15 under surface of the module. When floor panels do not readily align with support props, subsequent positioning of the floor panels is often tedious and difficult because it requires reworking areas already installed.

In addition, if a support prop or module of the floor system described in U.S. Patent No. 4,905,437 is damaged during or subsequent to installation, it
20 requires that the entire module be removed which can and often does entail the removal of numerous panels. This increases installation and repair time, as well as, the costs associated therewith.

Accordingly, what is needed is a raised floor system that incorporates a stable raised floor surface with a supporting structure that allows ready access to
25 the space created therein. In addition, the raised floor system must be designed for ease of installation over a base floor surface, as well as, allow for ease of subsequent repair.

Summary of the Invention

To achieve the foregoing and other objects, and in accordance with the purposes of the present invention as embodied and broadly described herein, the raised floor system of the present invention provides a uniform floor surface above
5 a base floor with space therebetween. The raised floor system comprises a low-profile base floor web assembly for installing on a base floor and floor panels that are secured thereto.

In the present invention, the base floor web consists of interconnected base floor web tiles. Each tile being comprised of elongate members integrally formed
10 between connection pods and/or docking pods in a square grid-like arrangement. Connection pods are formed between elongate members along two sides of the tile, whereas docking pods are formed between elongate members on the remaining two sides of the tile. The connection pods are circular and the docking pods are semi-circular. However, connection pods and docking pods can be
15 constructed in any complementing shape.

Further, adhesion pads are integrally formed between each elongate member and connection pod, as well as, between each docking pod and elongate member. At approximately the center of each adhesion pad is an aperture for receiving mastic or glue and on the underside of each adhesion pad are slightly
20 raised radial lines. When the base floor web is installed on a base floor, mastic is injected through the apertures of each adhesion pad so that the mastic is applied under the adhesion pad and between the radial lines without lifting the web off the base floor. The slightly raised area created by the radial lines on the underside of the adhesion pad ensures that the mastic is not squeezed out once the weight of
25 the floor panels is applied during installation, which is further described below.

Further, elongate members which form the perimeter of each base floor web tile have means for interconnecting with adjoining base floor web tiles to form the base floor web. The tile interconnection means comprises tabs and/or tab acceptors disposed on the perimeter elongate members of each base floor web tile.

Thus, tab acceptors of one base floor web tile are positioned to correspond to and receive respective tabs of adjoining base floor web tiles. Elongate members which form the interior grid of the base floor web tile may be provided with cable tie-downs for securing cables, wires and similar items thereto.

5 An alternate embodiment of the base floor web tile is comprised of a plurality of perimeter members and interior members arranged in a grid-like manner. In this embodiment, perimeter members form a square perimeter and interior members form an interior grid of the base floor web tile.

 Connection pods are integrally formed between perimeter members.
10 Further, a connection pod is integrally formed between the interior members at a midpoint of the tile. Extending from each perimeter connection pod is a tile interconnector, with either a male snap connector or a female snap connector formed at the end thereof that is furthest from the connection pod. The male snap connector may include three connection points. When installed, female snap
15 connectors of one base floor web tile snap onto the mating male snap connector of an adjoining base floor web tile. Thus, the female snap connectors and male snap connectors may be of various complementing shapes.

 The base floor web tile provides a matrix into which floor panel supports are secured. A floor panel support is a hollow metal cylinder of uniform height
20 with a raised lip around the circumference of its upper surface. The lipped upper surface has a slot formed through its center which is adapted to receive a corresponding floor panel support boss.

 The boss serves as a receptacle for a threaded fastener as well as a cushion to the raised floor panels. Each floor panel support has a base portion that
25 extends outward from and perpendicular to the main body of the floor panel support. The base portion has notches or small holes evenly spaced around its perimeter to resist the torque applied by the panel fastener during installation.

 A plastic injection molding process called "over-molding" or "insert-molding" is used to produce a base floor web tile assembly. To begin the over-
30 molding/insert-molding process, floor panel supports are loaded into a mold in an

automated injection-molding machine which performs the over-molding/insert-molding process. A plastic base floor web tile is then formed around the base portion of each floor panel support. A connection pod, including over-molded plastic stays, secures each floor panel support to the base floor web tile. The stays secure the base portion of the floor panel support to the web for installation and use but may still allow for the floor panel support to be removed and replaced. In addition, the notches in the bottom portion of the floor panel support are filled with plastic forming small "posts" during the over-mold process which prevent the supports from rotating during installation. Similarly, the floor panel support boss is formed on the upper surface of each floor panel support during the over-mold process. The raised lip around the upper circumference of the floor panel support accommodates receipt of the boss.

During installation, a floor panel is laid horizontally across the flat upper surface of the floor panel supports of a corresponding base floor web tile assembly. Each floor panel has a recess in its upper surface at each corner. The corner recess accommodates the width of the flat upper portion of the panel fastener. When the panel fastener is screwed into the plastic boss of the floor panel support, it secures the recessed corner of the floor panel therebetween. In this way, the panel fastener simultaneously secures the corners of four adjacent floor panels, thereby locating and evenly spacing the floor panels on the surface of the interconnected base floor web tile assemblies. Further, the panel fasteners are also constructed with sufficient tolerance to allow for small inconsistencies in the raised floor level. Thus, upon proper installation, the upper surface of the panel fastener is substantially flush with the upper surface of the floor panel and the lower surface of the floor panel is secured against the upper surface of the floor panel support.

The raised floor system of the present invention is installed on a base floor in what is described as a "top-down" process. Once the base floor web tile assemblies are interconnected, to cover the base floor in its entirety or any portion thereof, the assemblies need not be lifted to apply adhesive, *i.e.*, the "top" (upper

surface of the base floor web tile assembly) remains "down" (installed on the base floor) during application of the adhesive. A row of base floor web tile assemblies are laid down on the base floor and interconnected by interconnection means located along the perimeter of each base floor web tile. Mastic is then injected through the apertures of the adhesion pads that extend from each connection pod and docking pod of the base floor web tile. The mastic then fills the area created by the raised radial lines under the adhesion pad. Raised floor panels are then secured by a panel fastener to the upper surface of the base floor web tile assemblies as previously described. The area created by the radial lines under the adhesion pad retains mastic even after the weight of the floor panels is applied thereby assuring adhesion of the base floor web tile assembly to the base floor.

Brief Description of the Figures

The foregoing and other features and advantages of the invention will be apparent from the following, more particular description of a preferred embodiment of the invention, as illustrated in the accompanying drawings.

FIG. 1 is a perspective view of a raised floor module.

FIG. 2 is a perspective view of a first embodiment of a base floor web tile assembly.

FIG. 3 is a top plan view of a first embodiment of a base floor web tile.

FIG. 3A is a bottom plan view of a connection pod of FIG. 3.

FIG. 4 is a perspective view of a first embodiment of a floor panel support.

FIG. 4A is a top plan view of the floor panel support of FIG. 4.

FIG. 4B is a side plan view of the floor panel support of FIG. 4.

FIG. 4C is a cross-sectional view of the floor panel support of FIG. 4 taken along line 4C-4C.

FIG. 5 is a perspective view of a first embodiment of a floor panel support boss.

FIG. 5A is a side plan view of the floor panel support boss of FIG. 5.

FIG. 5B is a top plan view of the floor panel support boss of FIG. 5.

FIG. 6 is a side plan view of a panel fastener.

FIG. 6A is a top plan view of the panel fastener of FIG. 6.

5 FIG. 7 is a perspective view of a floor panel secured by a panel fastener to the base floor web tile assembly of FIG. 2.

FIG. 8 is a perspective view of two floor panels installed on respective interconnected base floor web tile assemblies.

FIG. 9 is a perspective view of a second embodiment of a base floor web tile assembly.

10 FIG. 10 is a top plan view of a second embodiment of a base floor web tile.

FIG. 11 is a perspective view of a connection pod and a tile interconnector of a base floor web tile of FIG. 10.

15 FIG. 12 is a perspective view of interconnected base floor web tiles of FIG. 10.

FIG. 13 is a bottom plan view of a connection pod of a base floor web tile of FIG. 10.

FIG. 14 is a perspective view of a second embodiment of a floor panel support.

20 FIG. 14A is a top plan view of the floor panel support of FIG. 14.

Detailed Description of the Preferred Embodiments

25 A preferred embodiment of the present invention is now described with reference to the figures, where like reference numbers indicate identical or functionally similar elements. Also in the figures, the left most digit of each reference number corresponds to the figure in which the reference number is first used. While specific configurations and arrangements are discussed, it should be understood that this is done for illustrative purposes only. A person skilled in the relevant art will recognize that other configurations and arrangements can be used

without departing from the spirit and scope of the invention. It will be apparent to a person skilled in the relevant art that this invention can also be employed in a variety of other applications, including wall and ceiling raised panel arrangements.

5 Referring to FIGS. 1 and 2, a raised floor module 100 is shown. The interconnection of raised floor modules 100 across the entirety of a base floor results in a stable, raised floor surface that allows ready access to the space below. FIG. 1 is a perspective view of a raised floor module 100 in accordance with the present invention. FIG. 2 is a perspective view of a base floor web tile assembly
10 104.

Raised floor module 100 includes a floor panel 102 and a corresponding base floor web tile assembly 104. Floor panel 102 may be made from a variety of materials, such as wood, particle board, concrete, metal or various combinations of these materials. Floor panel 102 is constructed so that each corner has a recess
15 106. In one embodiment, recess 106 is formed in a sector sized to receive a corresponding sector of an upper portion of a threaded panel fastener (not shown) used to secure floor panel 102 to base floor web tile assembly 104.

As shown in FIG. 2, base floor web tile assembly 104 includes a base floor web tile 202 fitted with a plurality of floor panel supports 204, wherein each floor
20 panel support 204 has a floor panel support boss 206 affixed to an upper surface thereof. Base floor web tile 202 and floor panel support boss 206 are preferably made of plastic but other resilient and flexible materials may be used. Floor panel support 204 is preferably made of metal. In another embodiment, the floor panel support can be made of wood, ceramic, plastic or any other material of suitable
25 strength. The base floor web tile assembly 104 is preferably constructed using an over-molding/insert-molding process which is discussed in greater detail below.

An alternate embodiment of base floor web tile assembly 104, as shown in FIG. 9, includes a base floor web tile 902 fitted with a plurality of floor panel supports 904, wherein each floor panel support 904 has a floor panel support boss
30 906 affixed to an upper surface thereof.

FIG. 3 is a top plan view of a base floor web tile 202. As shown in FIG. 3, base floor web tile 202 is comprised of a plurality of elongate members 302 and diagonal members 320 arranged in a grid-like manner. In the embodiment shown in FIG. 3, elongate members 302 form a square perimeter and an interior grid of base floor web tile 202. Diagonal members 320 provide reenforcement to the base floor web tile thereby preventing the base floor web tile from stretching during installation. In another embodiment, the elongate members may form a rectangular, an octagonal or other polygonal perimeter.

Along two sides of the perimeter of base floor web tile 202, connection pods 304 are integrally formed between elongate members 302. Further, the interior grid of base floor web tile 202 includes connection pods 304 integrally formed between elongate members 302. Along the remaining two sides of the perimeter of base floor web tile 202, docking pods 306 are integrally formed between elongate members 302. However, in another embodiment, connection pods and docking pods may be interchanged between elongate members on all four sides of the tile.

When installed, docking pods 306 of one base floor web tile 202 abut with connection pods 304 of an adjoining base floor web tile 202. Thus, connection pods 304 and docking pods 306 are necessarily of complementing shapes. In the embodiment of the present invention shown in FIG. 3, connection pods 304 are circular, whereas docking pods 306 are semi-circular. In a further embodiment, connection pods may be rectangular, octagonal or any other polygonal with correspondingly shaped docking pods.

Adhesion pads 308 are integrally formed between connection pods 304 and elongate members 302 as well as between docking pods 306 and elongate members 302. At approximately the center of each adhesion pad 306 is an aperture 310 for receiving mastic or glue and on the underside of each adhesion pad 306 are slightly raised radial lines 312, as shown in the embodiment of FIGS. 3 and 3A. In another embodiment, the adhesion pad may contain several apertures.

-11-

FIG. 10 is a top plan view of an alternate embodiment of base floor web tile 202 of FIG. 3. As shown in FIG. 10, base floor web tile 902 is comprised of a plurality of perimeter members 1002 and interior members 1012 arranged in a grid-like manner. In the embodiment shown in FIG. 10, perimeter members 1002 form a square perimeter and interior members 1012 form an interior grid of base floor web tile 902. A plurality of interior members 1012 are further arranged diagonally to provide reinforcement to base floor web tile 902 to prevent base floor web tile 902 from stretching during installation.

About the perimeter of base floor web tile 902, connection pods 1004 are integrally formed between perimeter members 1002, as shown in FIG. 10. Further, base floor web tile 902 includes connection pod 1004 integrally formed between interior members 1012 at a midpoint of the tile. Extending from each perimeter connection pod 1004 is tile interconnector 1006, with either a male snap connector 1016 or a female snap connector 1020 formed at the end thereof that is furthest from the connection pod. Male snap connector 1016 includes a plurality of connection points 1102, as shown in FIG. 11.

Adhesion pads 1008 are integrally formed between connection pods 1004 and interior members 1012. Adhesion pads 1008 are also integrally formed between connection pods 1004 and tile interconnectors 1006. At approximately the center of each adhesion pad 906 is an aperture 1010 for receiving mastic or glue and on the underside of each adhesion pad 906 are slightly raised portions 1302, as shown in the embodiment of FIGS. 11 and 13.

With reference to the embodiment of FIGS. 2, 3 and 3A, when the base floor web tile assemblies 104 are installed on a base floor, mastic is injected through apertures 310 so that it is applied under adhesion pads 306 and between radial lines 312 without lifting base floor web tile assembly 104 off the base floor. The slightly raised area created by radial lines 312 on the underside of adhesion pads 306 ensures that the mastic is not squeezed out once the weight of floor panels 102 is applied during installation, which is further described below. In another embodiment, the raised area under the adhesion pad is created by raised

portions 1302, as shown in FIG. 13. In a further embodiment, the underside of the adhesion pad is notched or scored from the lowest point of the aperture to accept mastic or glue therein.

5 The base floor web tiles have means to interconnect one to another to ultimately form the base floor web. In the embodiment of FIG. 3, elongate members 302 located on the perimeter of base floor web tile 202 have tabs 314 and tab acceptors 316 disposed thereon which function to interconnect one base floor web tile to an adjoining base floor web tile. The tab acceptors 316 of one base floor web tile are positioned to correspond to and receive respective tabs 314
10 of an adjoining base floor web tile 202. Further, interior elongate members 302 may be provided with cable tie-down locators 318, as shown in FIGS. 3 and 3A. In another embodiment, elongate members along the perimeter have complementing interlocking patterns by which the base floor web tiles are secured one to another.

15 In the alternate embodiment of the base floor web tile shown in FIG. 10, the base floor web is created by positioning female snap connector 1020 of one base floor web tile over a corresponding male snap connector 1016 of an adjoining base floor web tile and snapping them together, as shown in FIG. 12. Thus, female snap connectors 1020 and male snap connectors 1016 can be of various
20 complementing shapes. Further, perimeter members 1002 and/or interior members 1012 may be provided with cable tie-downs 1014, as shown in FIGS. 10 and 11.

Base floor web tiles 202 provide a matrix into which floor panel supports 204 are secured. FIG. 4 is a perspective view of a one embodiment of floor panel support 204. In this embodiment, floor panel support 204 is a hollow metal
25 cylinder 404 of uniform height that has a raised lip 402 around the circumference of its upper surface 412. Further, floor panel supports can be of any suitable shape, cross-section and/or size.

The lower edge of metal cylinder 404 forms a floor panel support base 408. Floor panel support base 408 is a circumferential band of material that
30 extends outward from and perpendicular to the main body of metal cylinder 404,

as shown in FIG. 4C. Notches 410 are evenly spaced around the perimeter of cylinder base 408, as shown in FIG. 4 and 4A. In one embodiment, the notches are semi-circular. In further embodiments, the notches may be v-shaped or u-shaped.

5 As also shown in FIG. 4A, the lipped upper surface 412 of metal cylinder 404 has a slot 406 formed therethrough which is adapted to receive a corresponding floor panel support boss 206. In one embodiment, a square slot is used to prevent the boss from rotating during installation and use. In an alternate embodiment shown in FIG. 14 and 14A, metal cylinder 1404 has a puzzle-piece-
10 shaped slot 1406 on an upper surface thereof. It would be apparent to one skilled in the relevant art that a variety of different shaped slots could be used to prevent rotation of the boss.

FIG. 5 is a perspective view of floor panel support boss 206. Floor panel support boss 206 is preferably made of plastic with a spoked upper portion 502 and an extended lower portion 504, as shown in FIGS. 5A and 5B. Boss upper
15 portion 502 serves to cushion floor panels 102, whereas boss lower portion 504 serves as a receptacle for panel fastener 600, shown in FIG. 6.

A plastic injection molding process called "over-molding" or "insert-molding" is used to produce a base floor web tile assembly, as shown in FIGS. 2.
20 To begin the over-molding/insert-molding process, floor panel supports 204 are loaded into a mold of an automated injection-molding machine which performs the over-molding/insert-molding process. In the base floor web tile assembly shown in FIG. 2, nine metal cylinders 404 of the type shown in detail in FIG. 4 are used. Connection pods 304 of base floor web tile 202 are then formed around floor
25 panel support base 408 at the lower portion of metal cylinder 404. Connection pods 304 have over-molded plastic stays 208 that extend over floor panel support base 408 of metal cylinder 404. Stays 208 secure metal cylinders 404 to base floor web tile 202 for installation and use but may still allow for removal and replacement of metal cylinders 404. In addition, notches 410 of cylinder base 408
30 fill with plastic forming small "posts" during the over-mold process which prevent

the cells from rotating during installation and use. Similarly, floor panel support boss 206 is formed on upper surface 412 of metal cylinder 404 during the over-mold process. Raised lip 402 around the upper circumference of metal cylinder 404 accommodates receipt of floor panel support boss 206.

5 During installation, floor panel 102 is laid horizontally across the flat upper surface of metal cylinders 404 of corresponding base floor web tile assembly 104, as shown in FIG. 7. In one embodiment, a substantially one-to-one relationship exists between each floor panel and its respective base floor web tile assembly. In another embodiment of the present invention, a plurality of floor panels are
10 configured so as to correspond to one base floor web tile assembly. Each floor panel has a recess 106 in its upper surface at each corner. The corner recess 106 accommodates the width of the flat upper portion 602 of threaded panel fastener 600, as shown in FIG. 6. When panel fastener 600 is screwed into floor panel support boss 206 of metal cylinder 404, it secures the corner of floor panel 102
15 thereto so that the upper surface of upper portion 602 of threaded panel fastener 600 is flush with the upper surface of floor panel 102, and the lower surface of floor panel 102 is secured against floor panel support boss 206 and upper surface 412 of metal cylinder 404, as shown in FIG. 8. In this way, panel fastener 600 simultaneously secures the corners of four adjacent panels, thereby locating and
20 evenly spacing the panels on the upper surface of the base floor web tile assembly. Further, panel fasteners 600 are constructed with sufficient tolerance to allow for small inconsistencies in the floor level upon installation.

 The raised floor system of the present invention is installed on a base floor in a "top-down" process. Once the base floor web tile assemblies are
25 interconnected, to cover the entire base floor or any portion thereof, the assembly need not be lifted to apply adhesive, *i.e.*, the "top" (upper surface of the base floor web tile assembly) remains "down" (installed on the base floor) during application of the adhesive. Thus, a row of base floor web tile assemblies 104 are laid down on the base floor and interconnected by the mating of tabs 314 of one assembly
30 with tab acceptors 316 of an adjoining assembly. In the embodiment of base floor

-15-

web tile assembly 104 shown in FIG.9, female snap connectors 1020 of one base floor web tile 902 snap onto the mating male snap connector 1016 of an adjoining base floor web tile 902, as shown in FIG. 12. Mastic is then injected through apertures 310 of adhesion pads 308 of the base floor web tile. The mastic fills the space created under the adhesion pads due to raised radial lines 312 on the underside thereof. The configuration of the adhesion pads, *i.e.*, the placement of apertures and raised radial lines thereunder, eliminates the need to lift the base floor web tile to apply the adhesive.

Raised floor panels 102 are then secured by a threaded panel fastener 600 to the upper surface of floor panel supports 204 of base floor web tile assemblies 104, as previously described. During this step of the installation, the area formed between the raised radial lines of the adhesion pad retain the glue and prevent it from being squeezed out from under the base floor web once the floor panel is secured thereto assuring a firm bond with the base floor.

While the invention has been particularly shown and described with reference to preferred embodiments thereof, it will be understood by those skilled in the art that various changes in form and details may be made therein without departing from the spirit and scope of the invention.

What Is Claimed Is:

1. A raised floor system for installation over a base floor, comprising:
5 surface;
a plurality of floor panel supports, each of said floor panel supports having an upper portion and a base portion, wherein the base portion of at least one of said floor panel supports is releasably attached to said base floor web; and
10 a plurality of floor panels, each of said floor panels having at least one recess by which said floor panel is releasably secured to the upper portion of at least one of said floor panel supports.
2. The raised floor system of claim 1, wherein each of said floor panel supports further comprises a floor panel support boss secured to the upper portion thereof.
- 15 3. The raised floor system of claim 1, further comprising:
a plurality of panel fasteners for releasably securing the recess of each of said floor panels to the upper portion of at least one of said plurality of floor panel supports.
- 20 4. The raised floor system of claim 1, wherein said base floor web comprises a plurality of base floor web tiles.
5. The raised floor system of claim 4, wherein each of said base floor web tiles comprises:
25 a plurality of connection pods integrally connected by a plurality of elongate members that are arranged in a grid-like manner, wherein each of said connection pods is configured to receive the base portion of one of said floor panel supports;

-17-

a plurality of tabs formed on the elongate members that form a periphery of each of said base floor web tiles; and

a plurality of tab acceptors formed on the elongate members that form the periphery of each of said base floor web tiles, wherein said tab acceptors on one of said base floor web tiles are positioned to correspond to and receive
5 respective ones of said tabs of an adjoining one of said base floor web tiles.

6. The raised floor system of claim 4, wherein each of said base floor web tiles comprises:

a plurality of connection pods integrally connected by a plurality of elongate members that are arranged in a grid-like manner, wherein each of said
10 connection pods is configured to receive the base portion of one of said floor panel supports;

a plurality of tile interconnectors integrally connected to and extending from the connection pods;

15 a plurality of male snap connectors formed on the tile interconnectors; and

a plurality of female snap connectors formed on the tile interconnectors, wherein said male snap connectors on one of said base floor web tiles are positioned to correspond to and snap into respective ones of said female
20 snap connectors of an adjoining one of said base floor web tiles.

7. The raised floor system of claim 1, wherein at least one of said plurality of floor panel supports is cylindrical.

8. The raised floor system of claim 1, wherein at least one of said plurality of floor panel supports is made of metal.

-18-

9. The raised floor system of claim 4, wherein each of said plurality of base floor web tiles is configured to proportionally correspond to one of said plurality of floor panels.

5 10. The raised floor system of claim 5, wherein each of said connection pods comprises at least one adhesion portion having a top surface, a bottom surface and an aperture formed therethrough.

11. The raised floor system of claim 6, wherein each of said connection pods comprises at least one adhesion portion having a top surface, a bottom surface and an aperture formed therethrough.

10 12. The raised floor system of claim 10, wherein the bottom surface of the adhesion portion has a raised area such that when the base floor web tile is laid upon the base floor, a space is created between the bottom surface of the adhesion portion and the base floor.

15 13. The raised floor system of claim 11, wherein the bottom surface of the adhesion portion has a raised area such that when the base floor web tile is laid upon the base floor, a space is created between the bottom surface of the adhesion portion and the base floor.

20 14. The raised floor system of claim 12, wherein the raised area on the bottom surface of the adhesion portion comprises a plurality of radial lines extending from the aperture.

15. The raised floor system of claim 1, wherein said base floor web is made of plastic.

16. A raised floor system for installation over a base floor, comprising:

-19-

a plurality of low-profile base floor web tiles, each of said base floor web tiles having an upper surface and a lower surface and means for interconnecting one of said plurality of base floor web tiles to another of said plurality of base floor web tiles to form a base floor web;

5 a plurality of floor panel supports, each of said plurality of floor panel supports having an upper portion and a base portion, wherein the base portion of at least one of said floor panel supports is releasably attached to said base floor web;

10 a floor panel support boss secured to the upper portion of each of said floor panel supports;

a plurality of floor panels, each of said floor panels having at least one recess by which said floor panel can be releasably secured to said floor panel support boss; and

15 a panel fastener disposed in said floor panel support boss to secure said recess of said floor panel to the upper portion of at least one of said floor panel supports.

17. A method for installing a raised floor system, comprising the steps of:

positioning a first base floor web tile assembly on a base floor;

20 interconnecting a second base floor web tile assembly to said first base floor web tile assembly on the base floor;

applying an adhesive below said first and second base floor web tile assemblies;

25 positioning a first floor panel substantially entirely above said first base floor web tile assembly;

positioning a second floor panel substantially entirely above said second base floor web tile assembly; and

securing said first and second floor panels to said first and second base floor web tile assemblies, respectively.

-20-

18. The method of claim 17, wherein said interconnecting step comprises the steps of:

engaging interconnecting means of said first base floor web tile assembly with corresponding interconnecting means of said second base floor web tile assembly to form a base floor web.

19. The method of claim 17, wherein said applying step comprises the steps of:

injecting a glue through an aperture of said first base floor web tile assembly and through an aperture of said second base floor web tile assembly to an underside thereof, wherein the underside of said first and said second base floor web tile assemblies remain substantially in contact with the base floor.

20. The method of claim 17, wherein said securing step comprises the step of:

inserting a panel fastener into said first base floor web tile assembly at a point that corresponds to an at least one corner of said first floor panel and an at least one corner of said second floor panel and fastening the panel fastener into said first base floor web tile assembly.

21. The method of claim 17, wherein said first base floor web tile assembly comprises:

a low-profile base floor web tile having an upper surface and a lower surface;

a plurality of floor panel supports, each of said floor panel supports having an upper portion and a base portion, wherein the base portion of at least one of said floor panel supports is releasably attached to said base floor web tile; and

a floor panel support boss secured to the upper portion of at least one of said plurality of floor panel supports.

-21-

22. The raised floor system of claim 4, wherein a multiple of said plurality of floor panels are configured so as to correspond to one of said plurality of base floor web tiles.

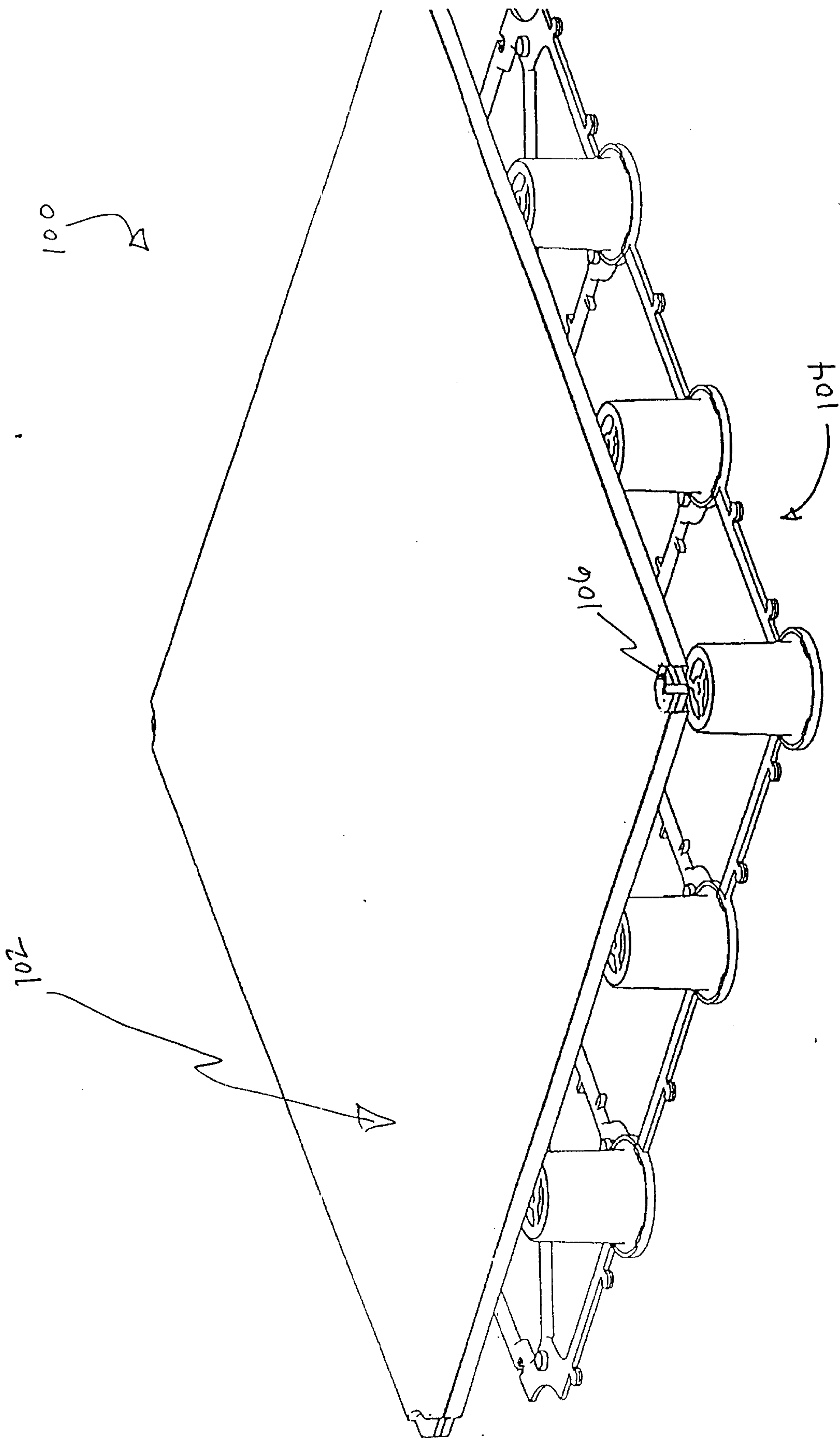

FIG. 1

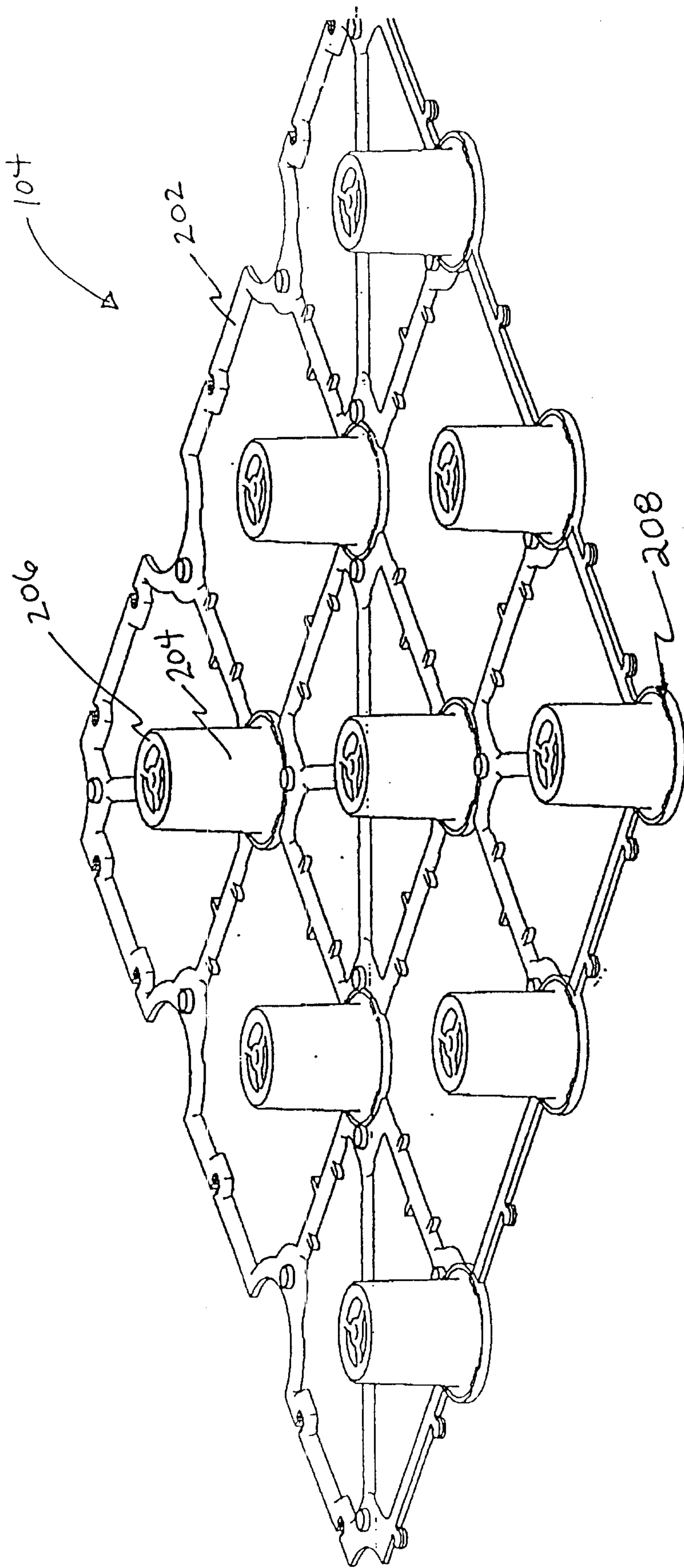

FIG. 2

FIG. 3

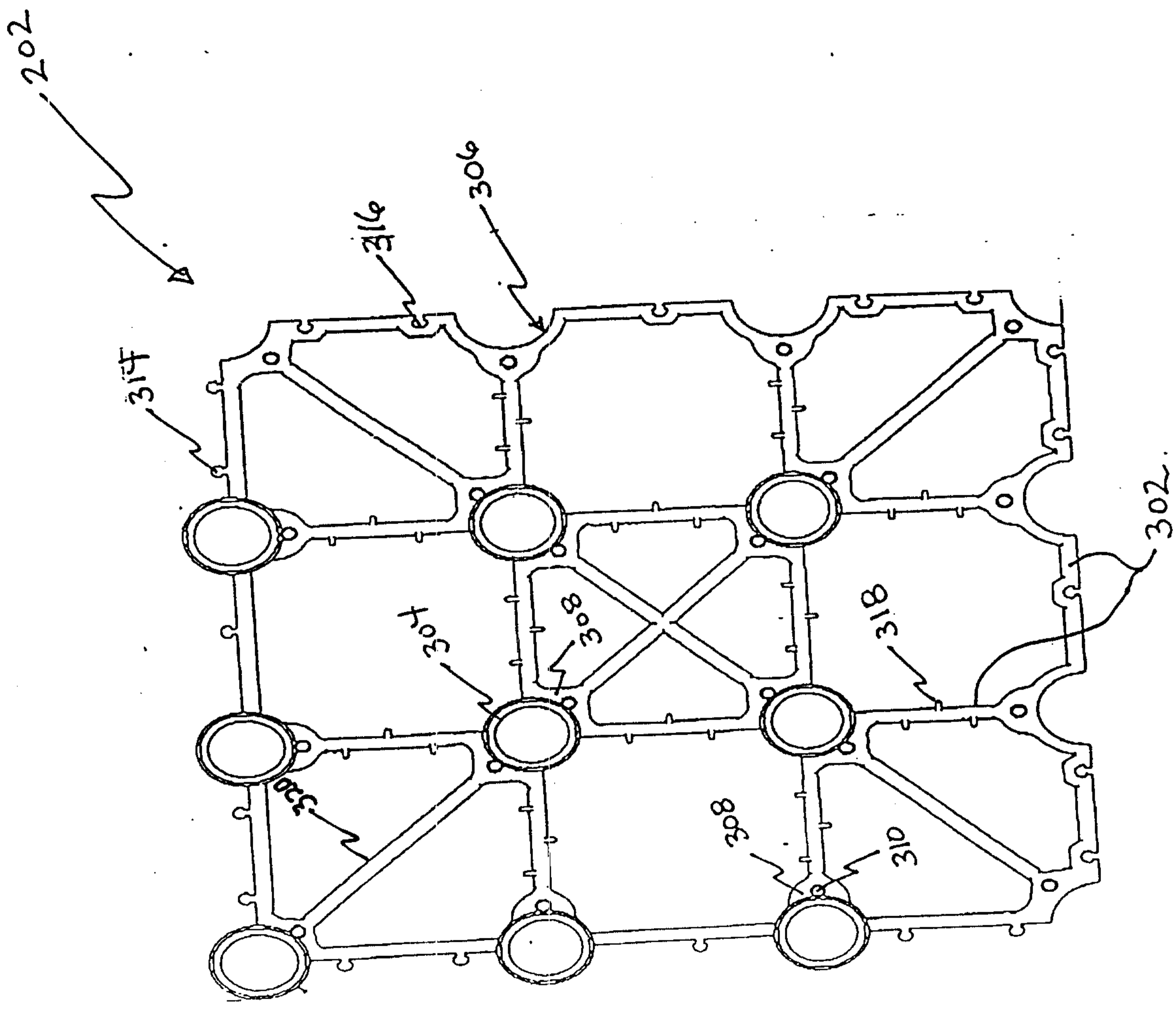
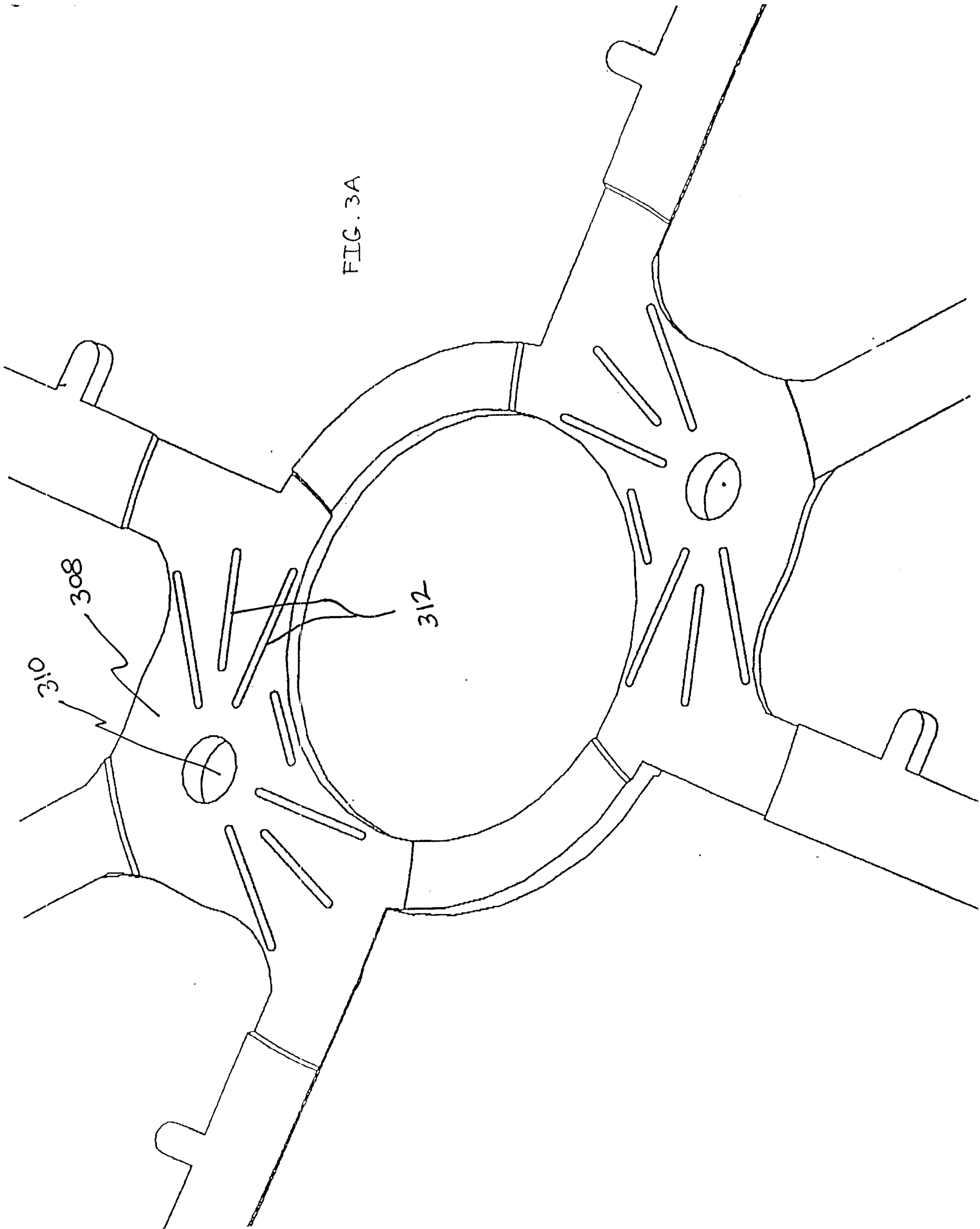

FIG. 3A



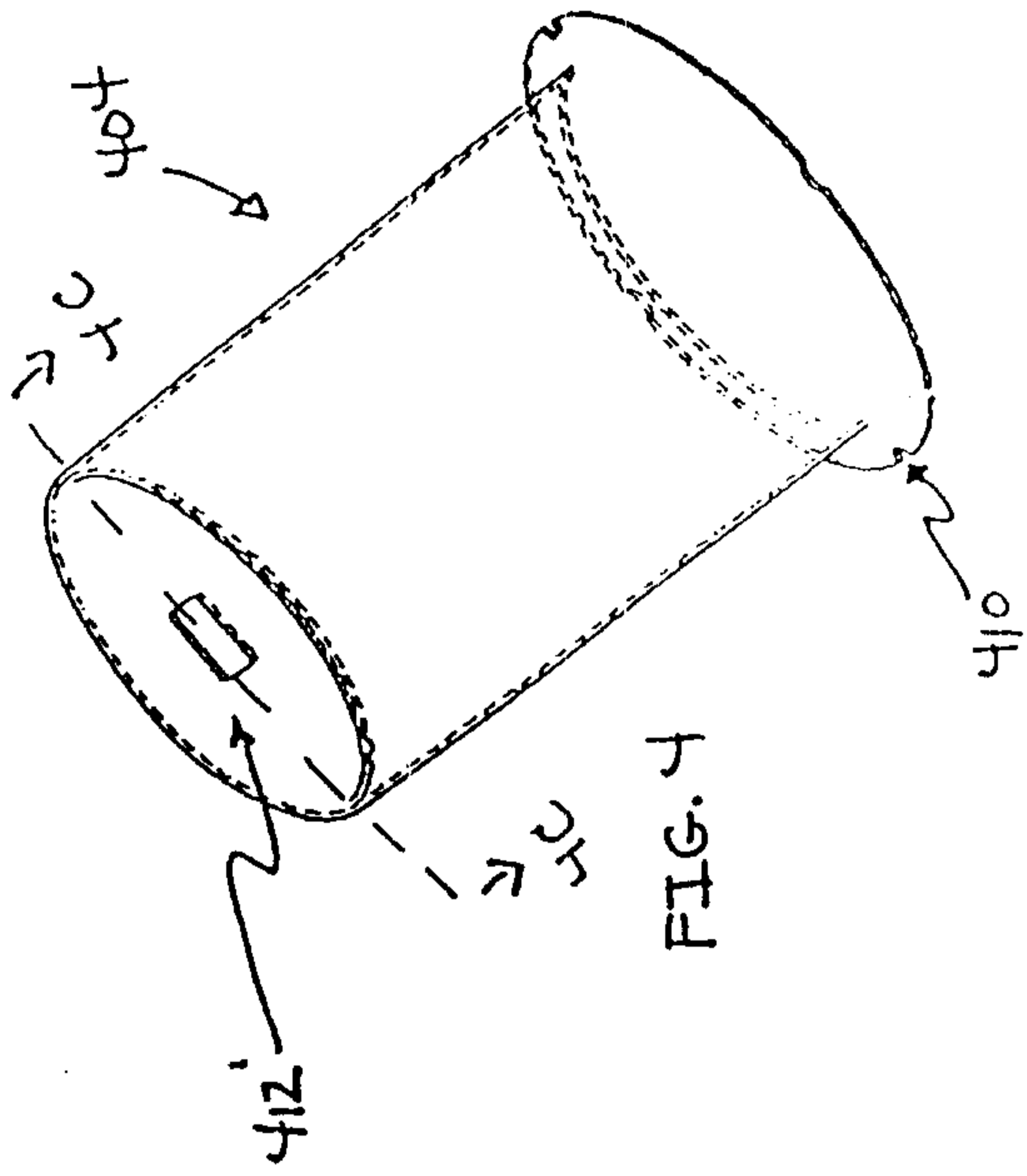

FIG. 4

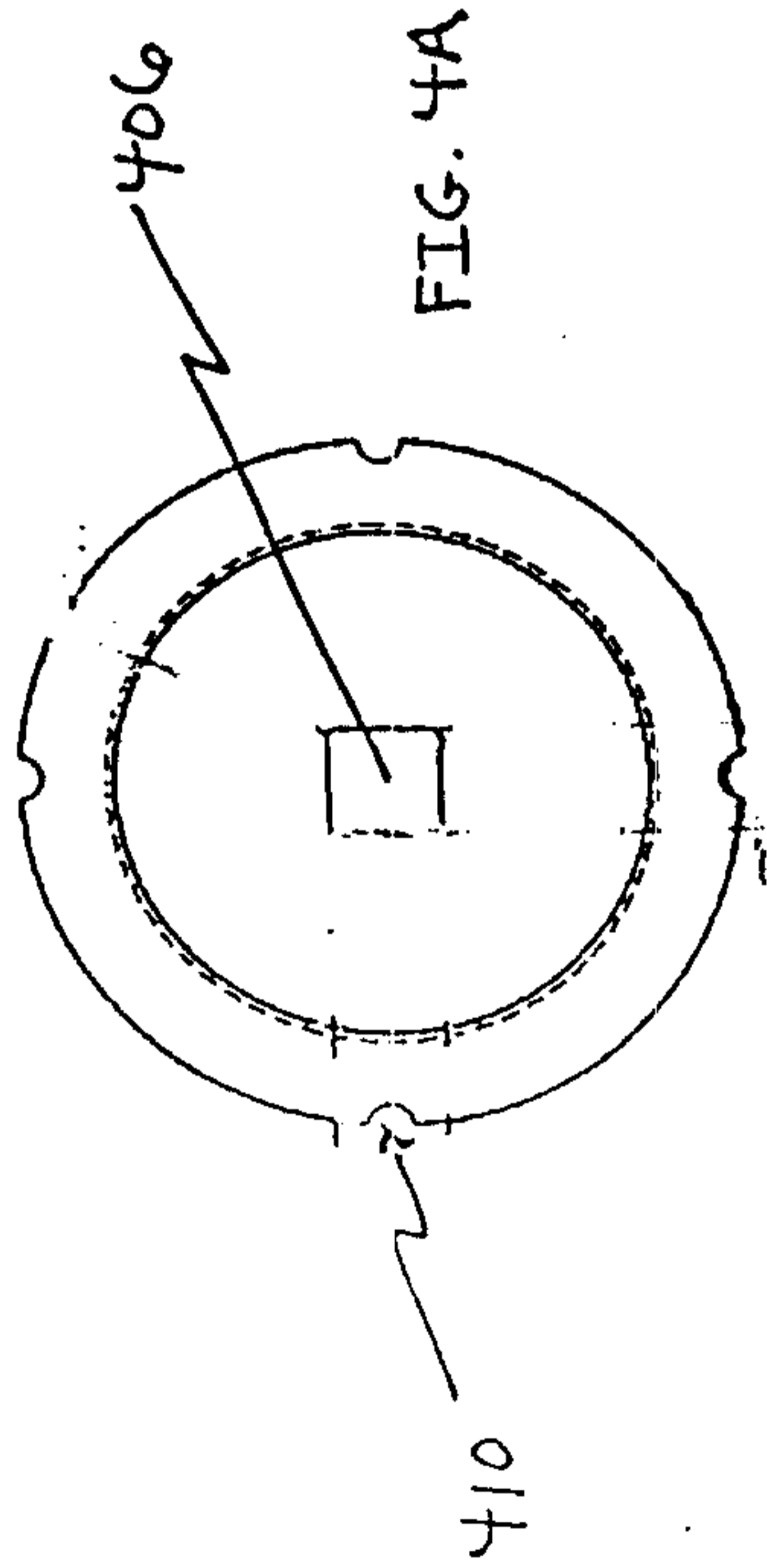

FIG. 4A

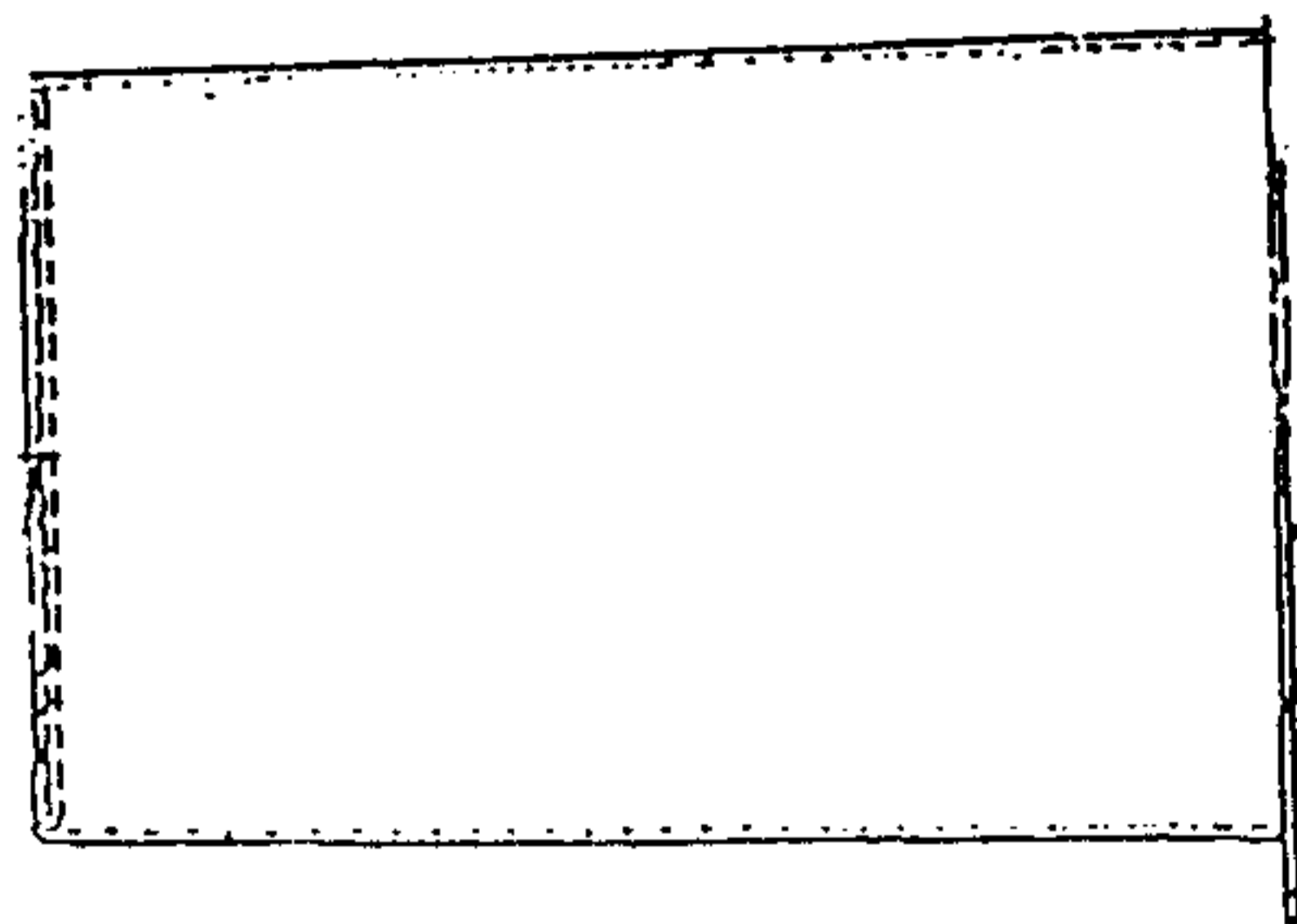

FIG. 4B

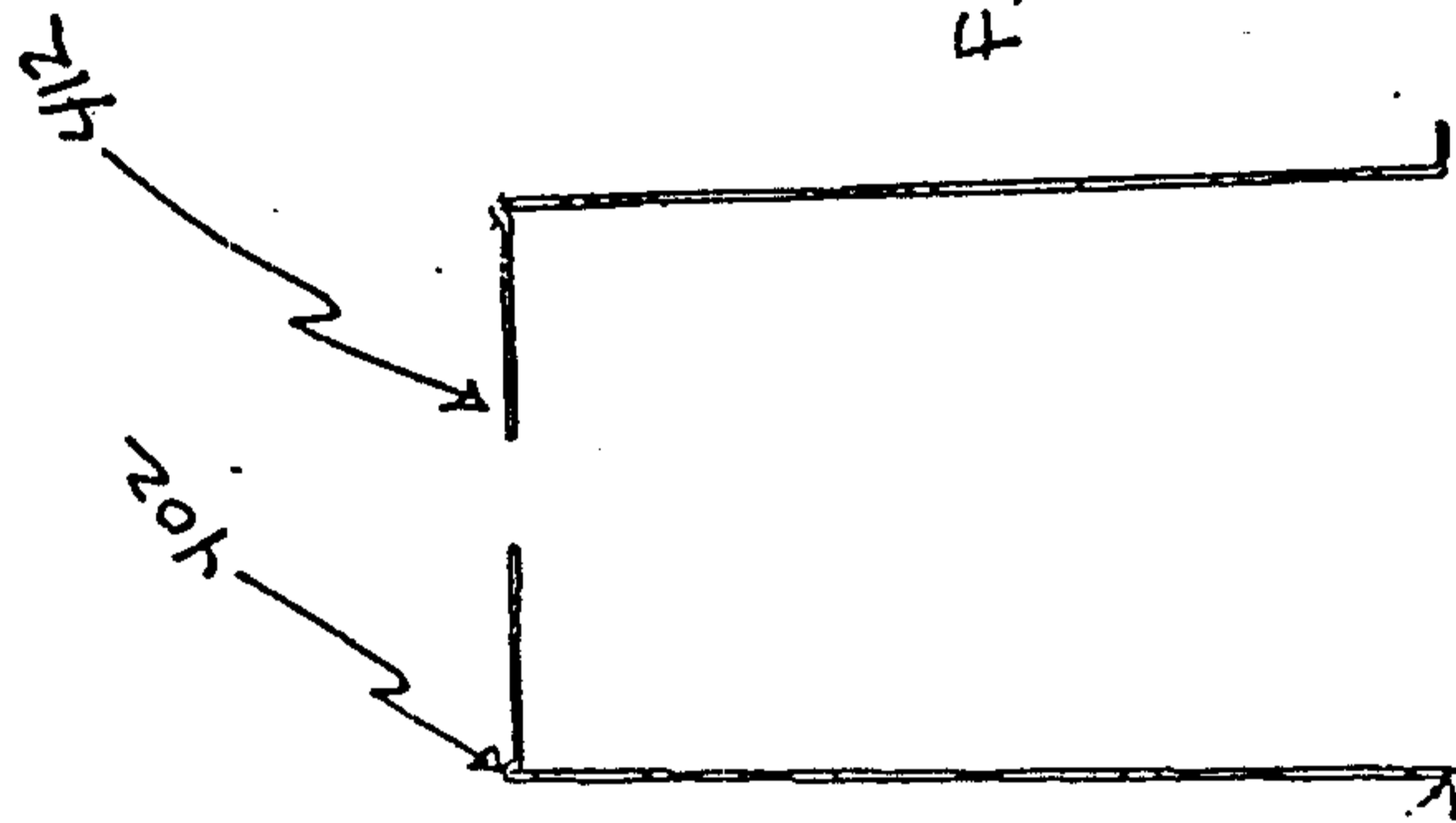

FIG. 4C

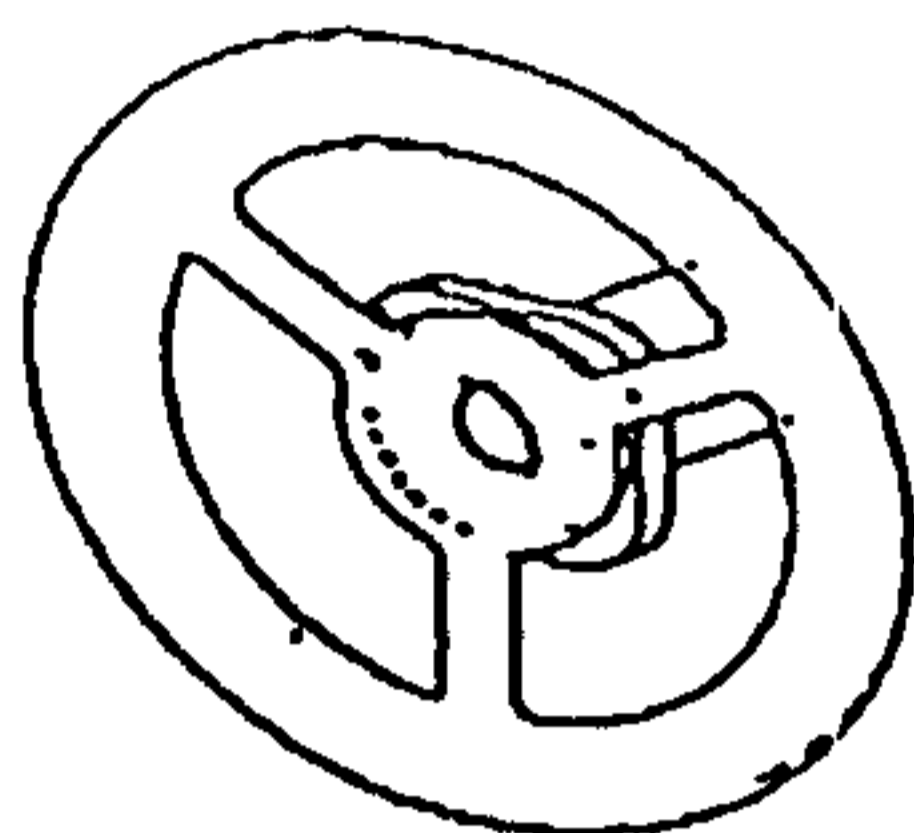

FIG. 5

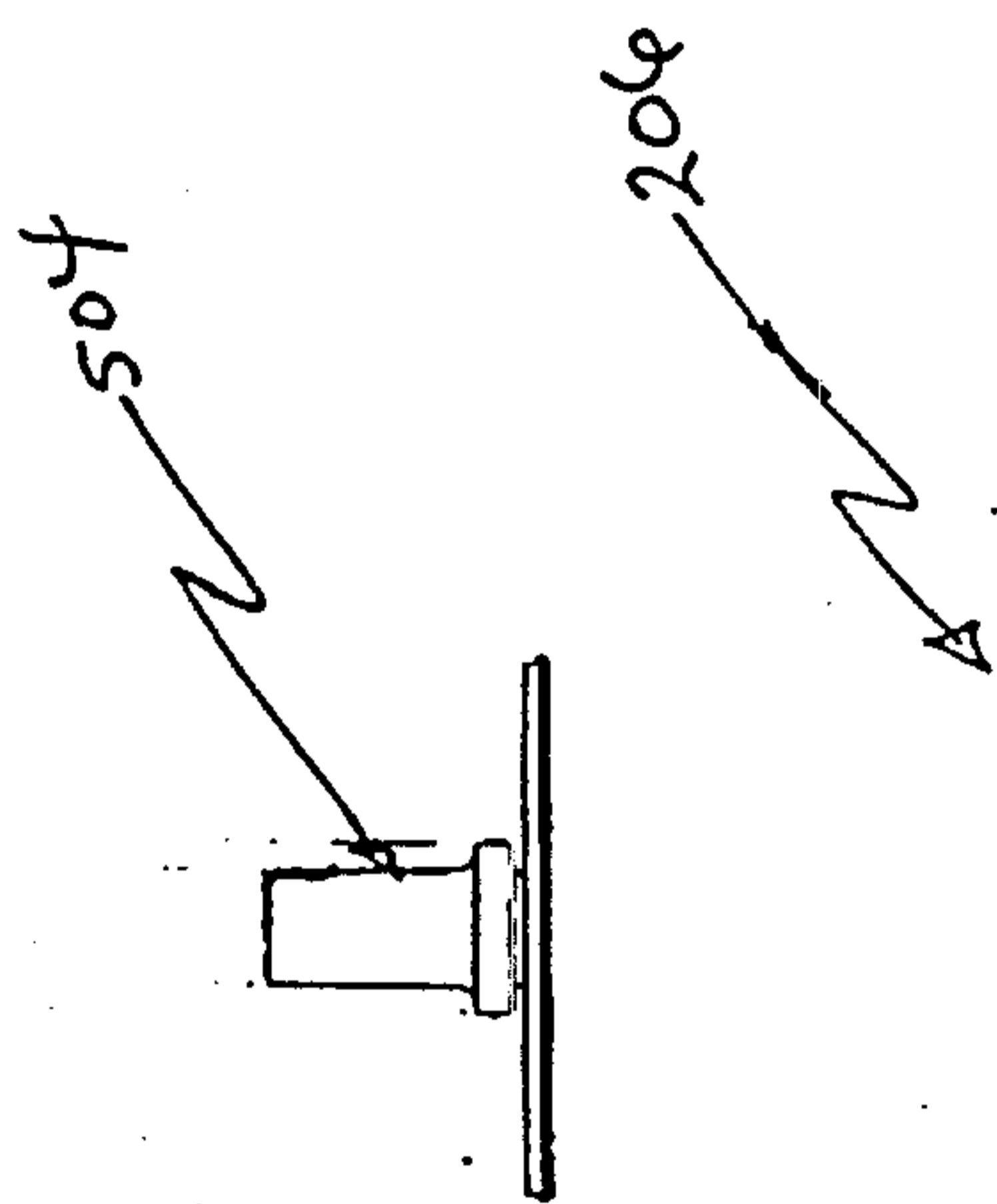
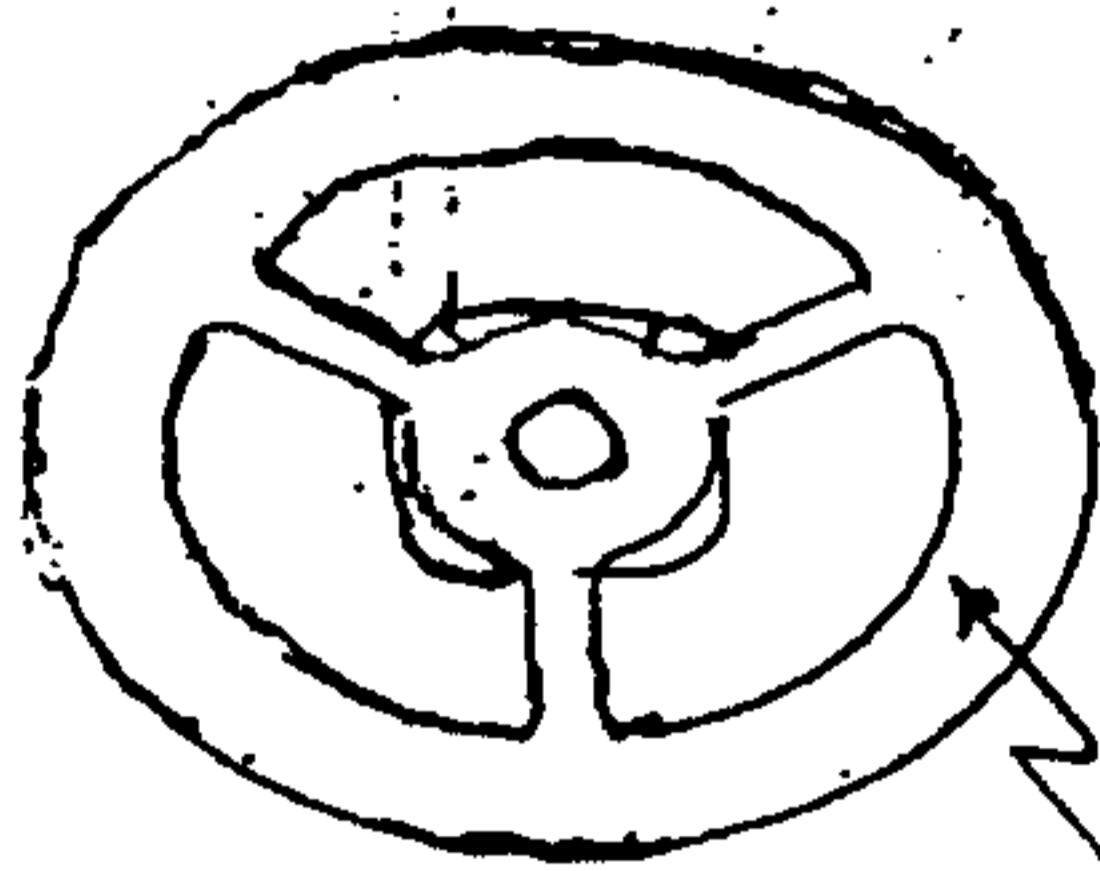

FIG. 5A



502

FIG. 5B

FIG. 6A

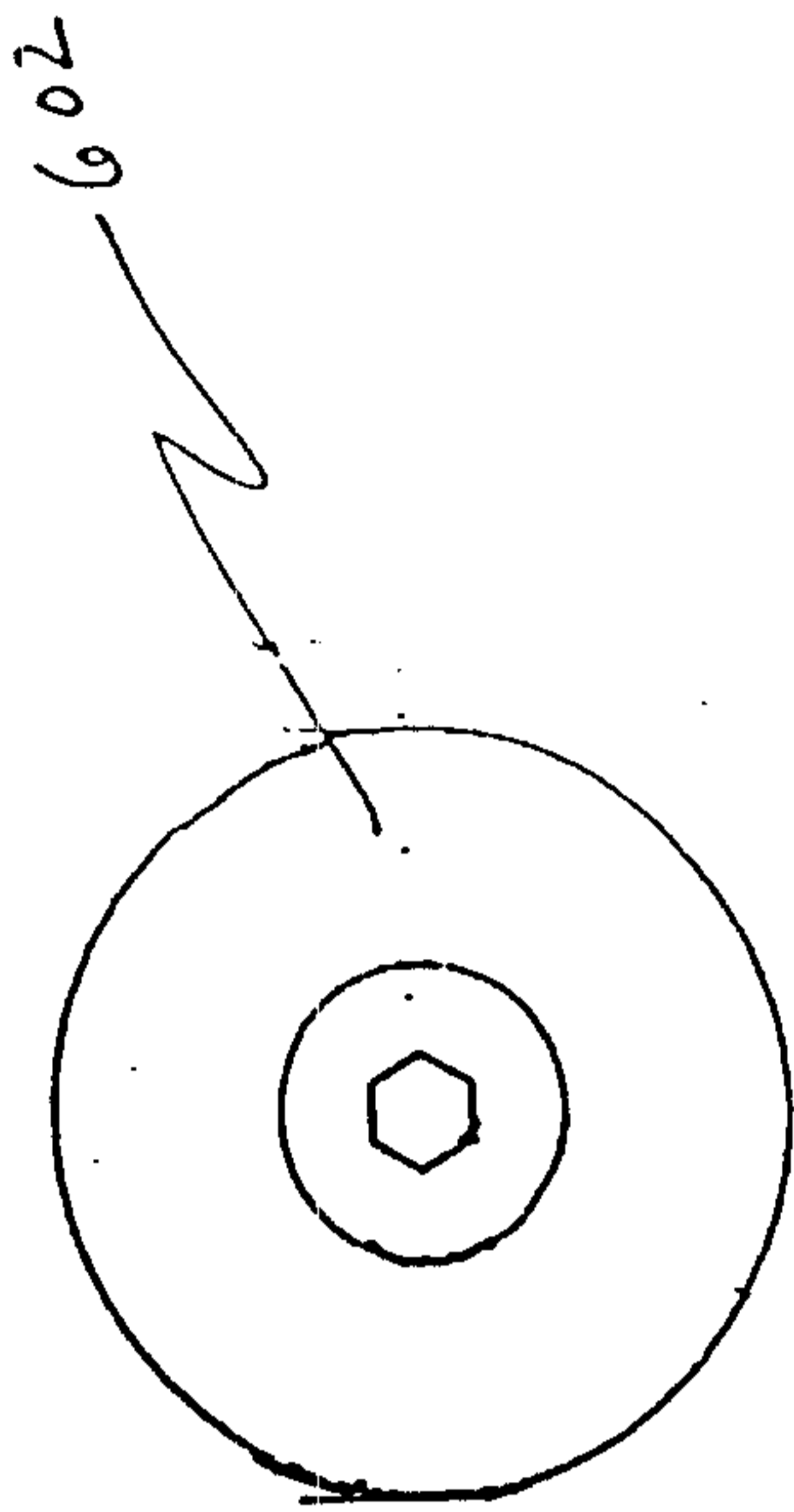

600

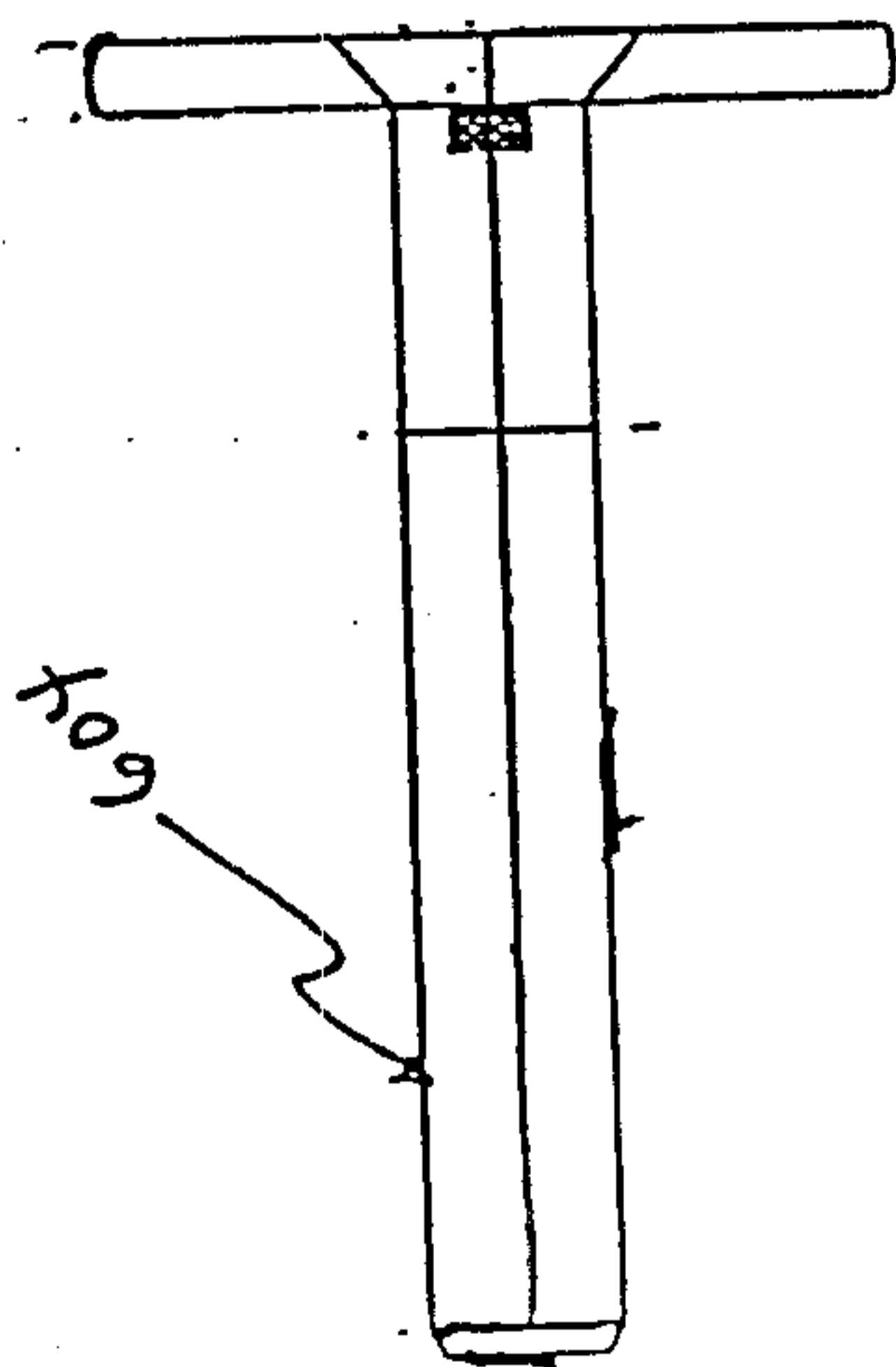

FIG. 6

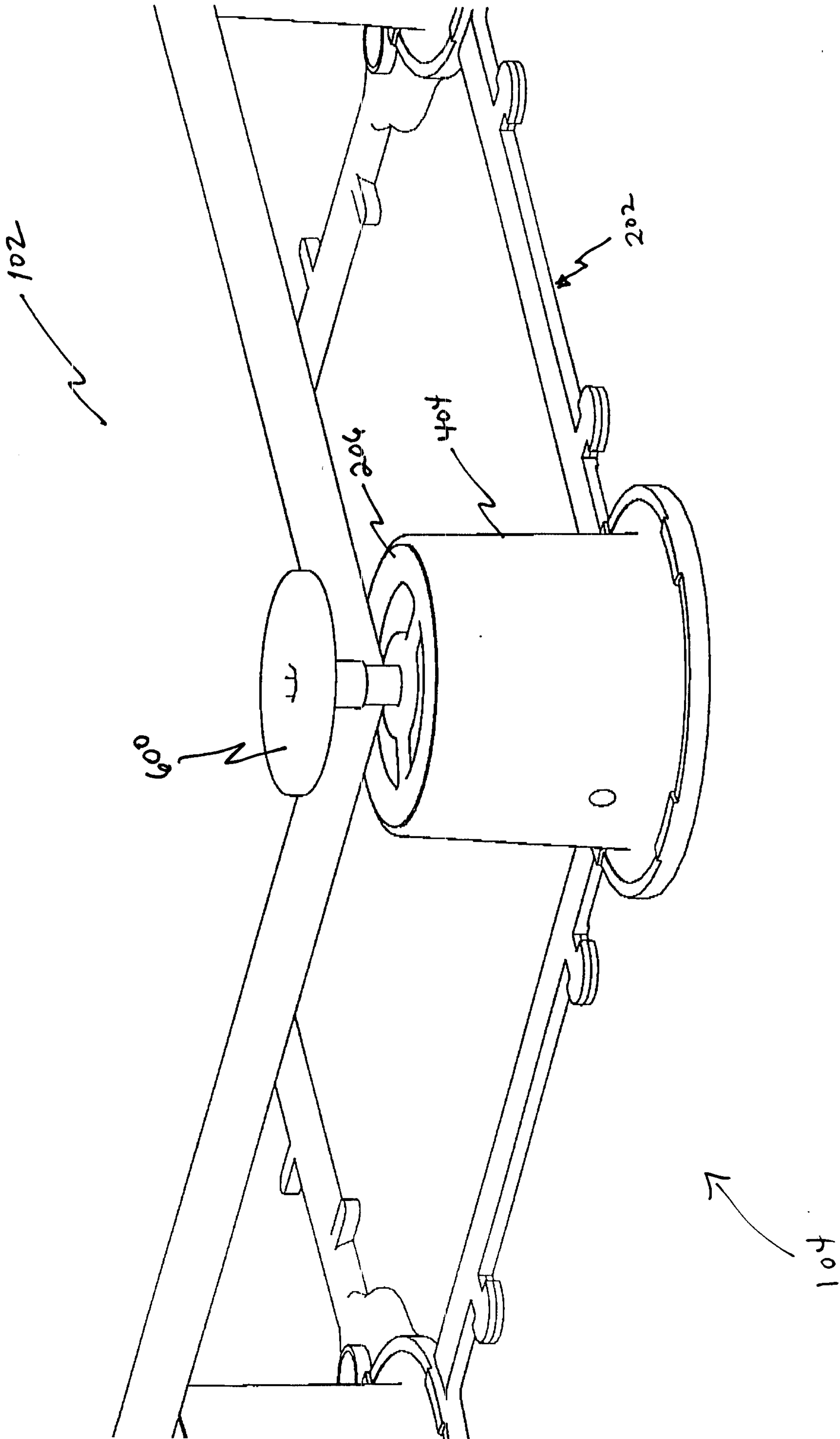

Fig. 7

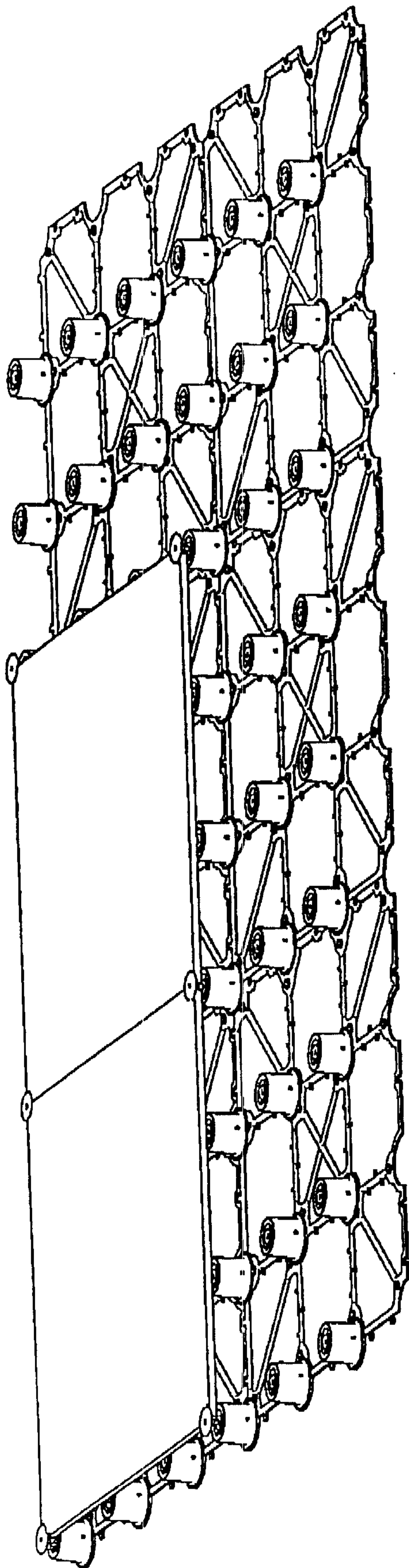

Fig. 8

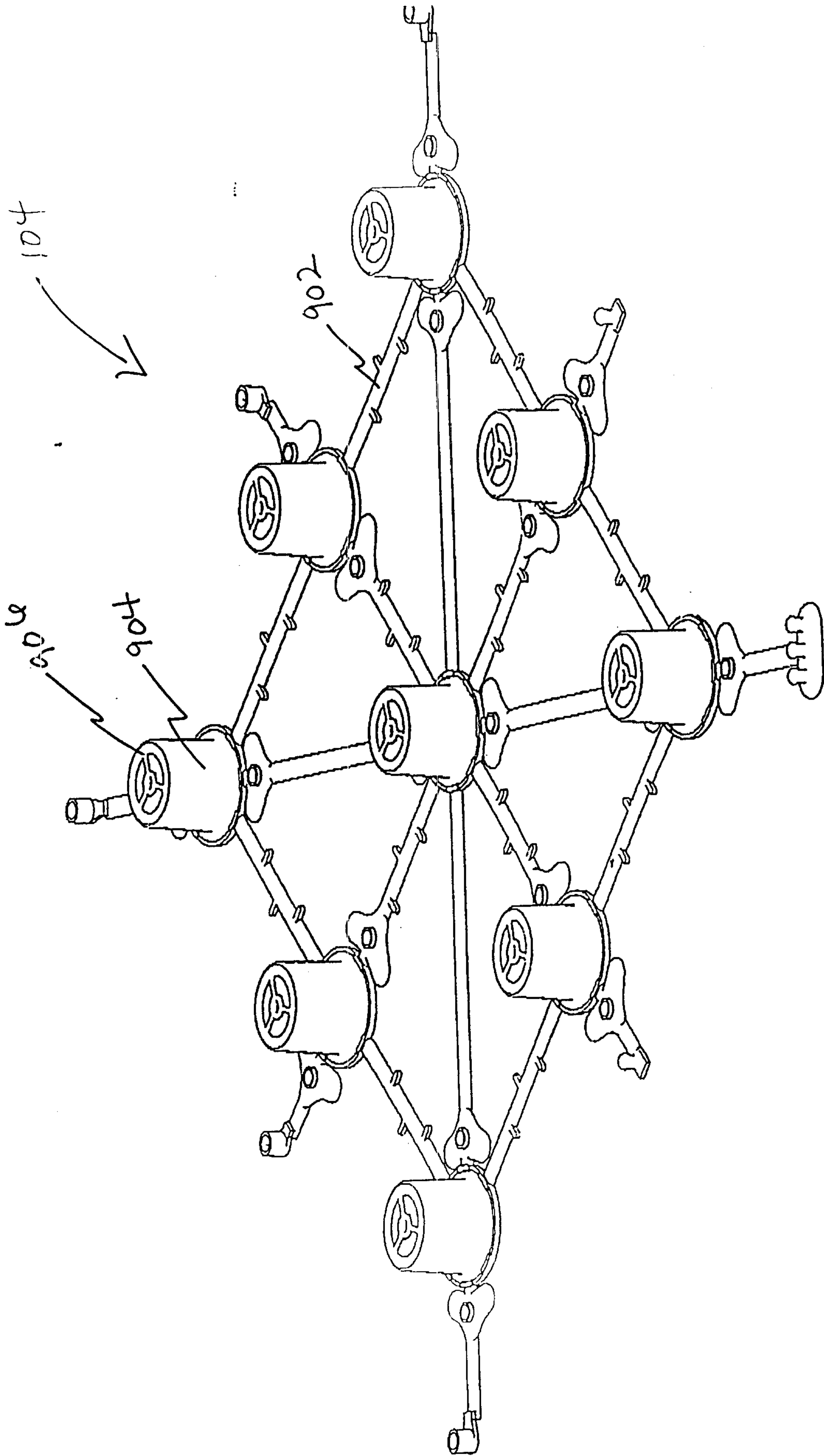

FIG. 9

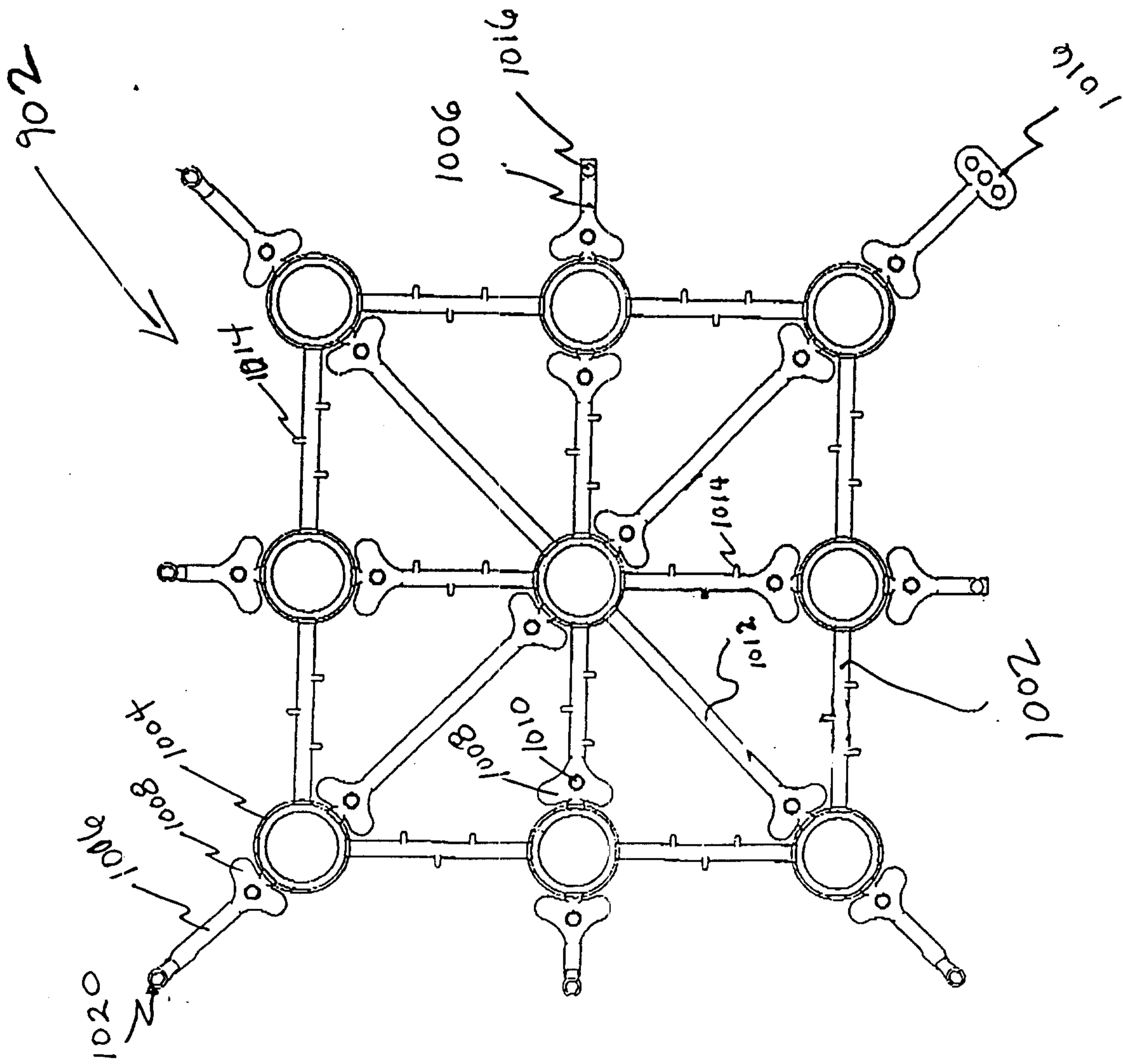

FIG. 10

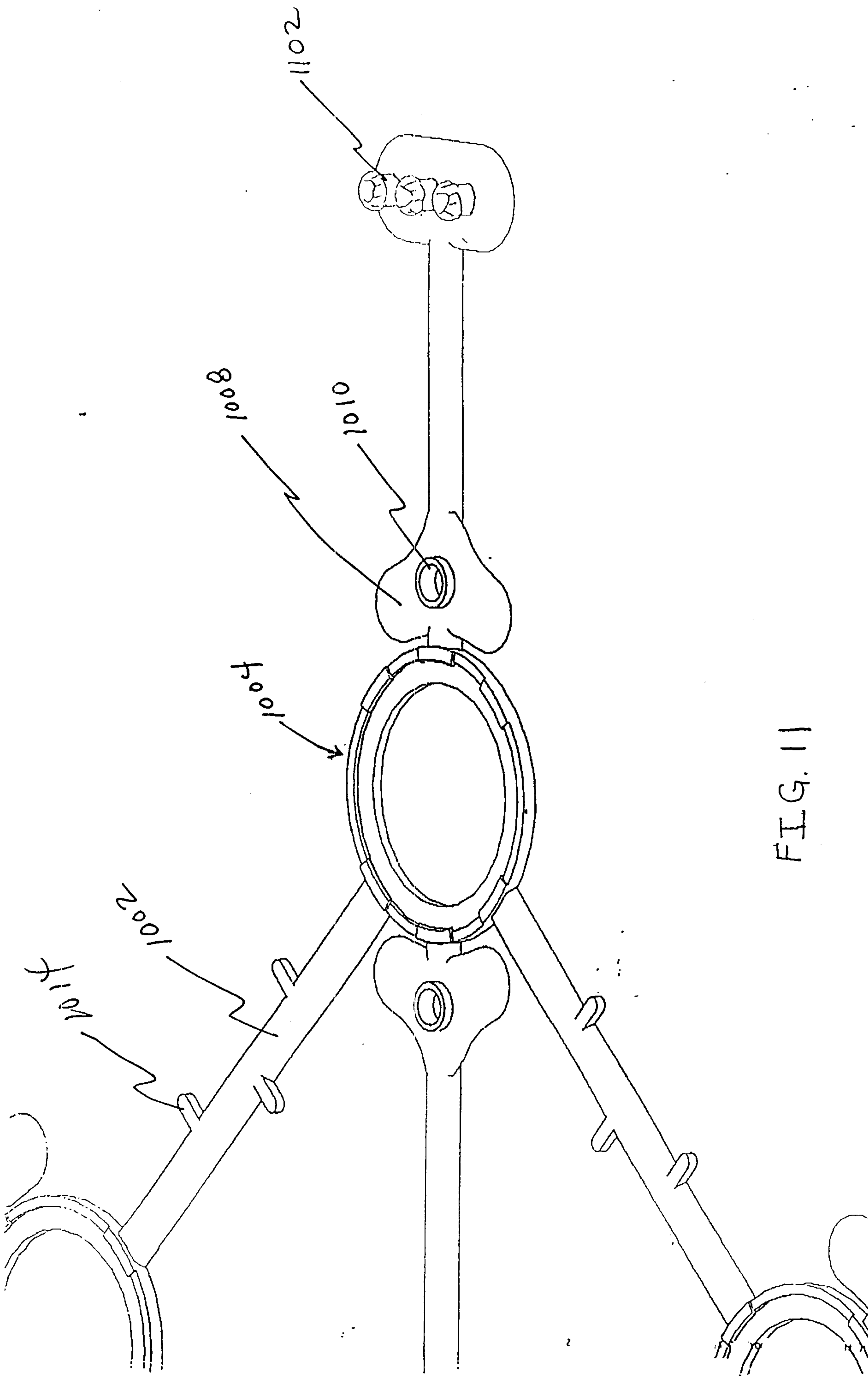

FIG. 11

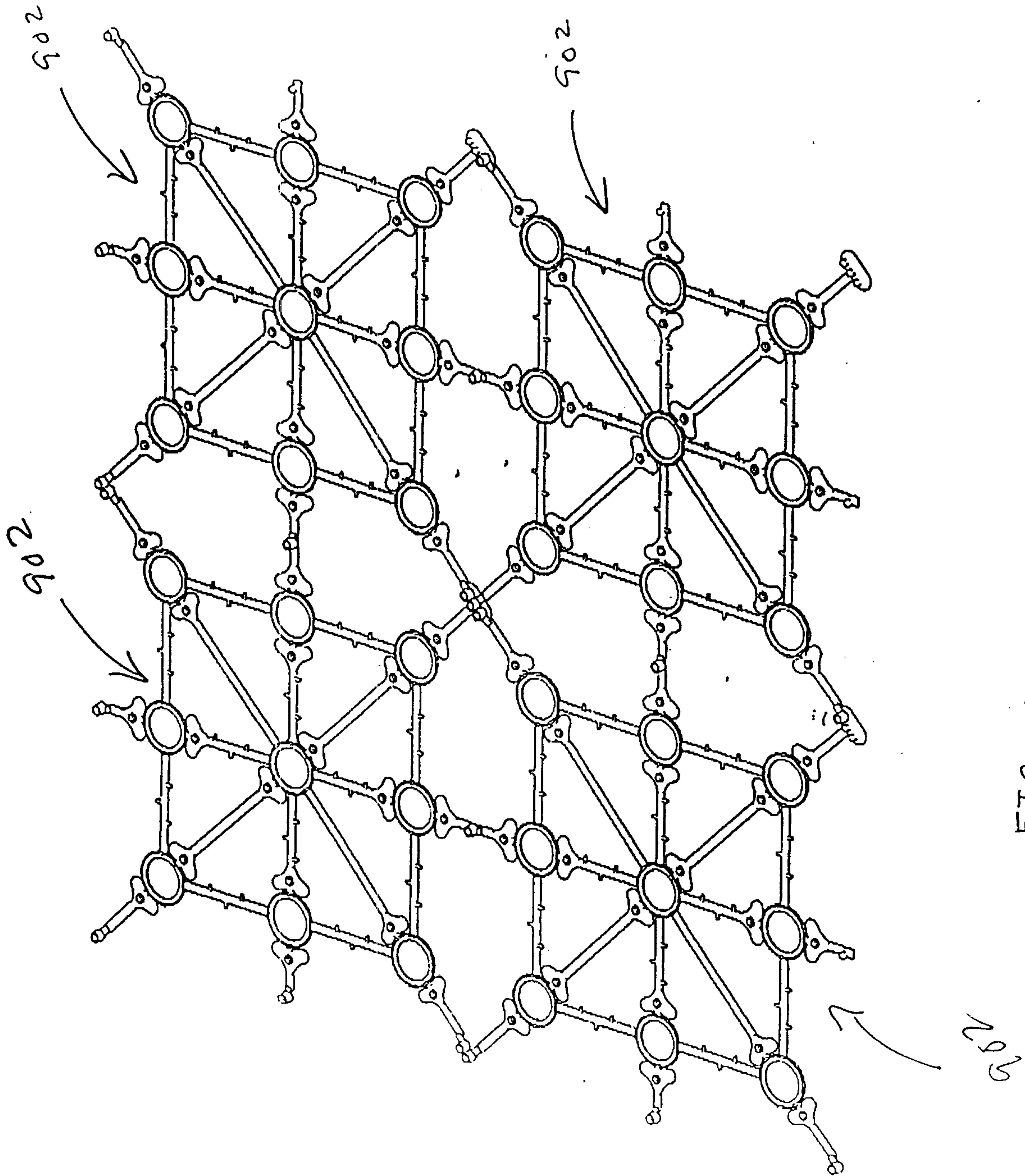

FIG. 12

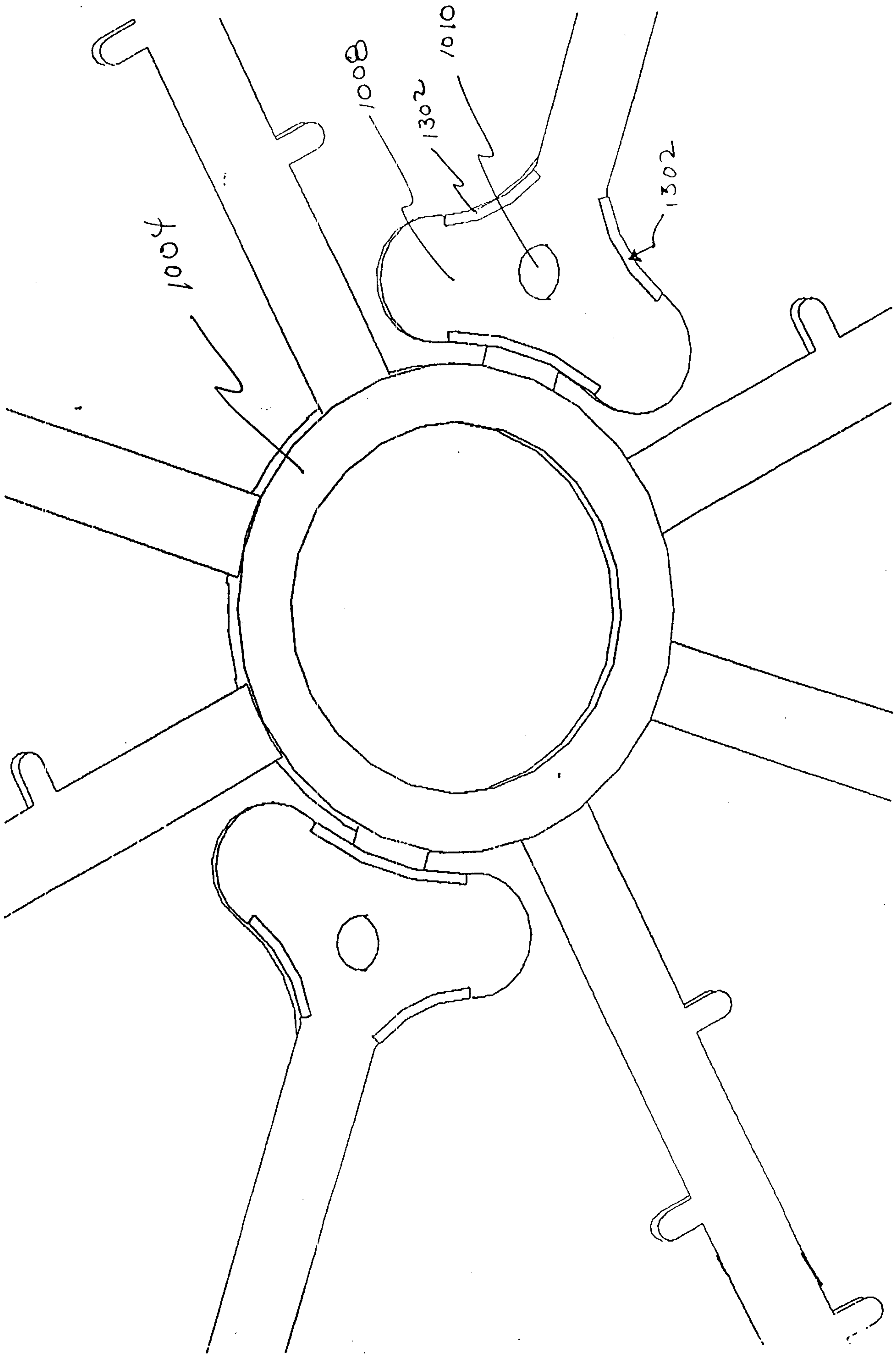

FIG. 13

