

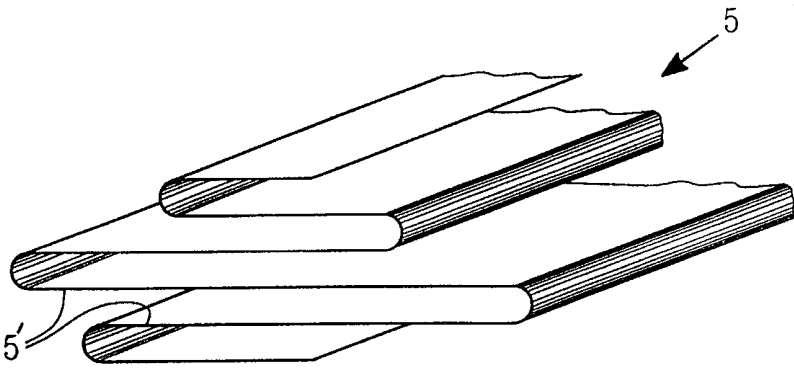

INTERNATIONAL APPLICATION PUBLISHED UNDER THE PATENT COOPERATION TREATY (PCT)

<p>(51) International Patent Classification ⁶ : A61F 13/15</p>	<p>A1</p>	<p>(11) International Publication Number: WO 99/63920</p> <p>(43) International Publication Date: 16 December 1999 (16.12.99)</p>
<p>(21) International Application Number: PCT/SE99/00964</p> <p>(22) International Filing Date: 4 June 1999 (04.06.99)</p> <p>(30) Priority Data: 9802077-9 11 June 1998 (11.06.98) SE</p> <p>(71) Applicant (for all designated States except US): SCA HYGIENE PRODUCTS AB [SE/SE]; S-405 03 Göteborg (SE).</p> <p>(72) Inventor; and (75) Inventor/Applicant (for US only): WALLSTRÖM, Leif [SE/SE]; Geteryggsgatan 14, S-416 78 Göteborg (SE).</p> <p>(74) Agent: GÖTEBORGS PATENTBYRÅ DAHLS AB; Sjöporten 4, S-417 64 Göteborg (SE).</p>		<p>(81) Designated States: AE, AL, AM, AT, AU, AZ, BA, BB, BG, BR, BY, CA, CH, CN, CU, CZ, DE, DK, EE, ES, FI, GB, GD, GE, GH, GM, HR, HU, ID, IL, IN, IS, JP, KE, KG, KP, KR, KZ, LC, LK, LR, LS, LT, LU, LV, MD, MG, MK, MN, MW, MX, NO, NZ, PL, PT, RO, RU, SD, SE, SG, SI, SK, SL, TJ, TM, TR, TT, UA, UG, US, UZ, VN, YU, ZA, ZW, ARIPO patent (GH, GM, KE, LS, MW, SD, SL, SZ, UG, ZW), Eurasian patent (AM, AZ, BY, KG, KZ, MD, RU, TJ, TM), European patent (AT, BE, CH, CY, DE, DK, ES, FI, FR, GB, GR, IE, IT, LU, MC, NL, PT, SE), OAPI patent (BF, BJ, CF, CG, CI, CM, GA, GN, GW, ML, MR, NE, SN, TD, TG).</p> <p>Published <i>With international search report. Before the expiration of the time limit for amending the claims and to be republished in the event of the receipt of amendments. In English translation (filed in Swedish).</i></p>
<p>(54) Title: ABSORBENT STRUCTURE</p>		
		
<p>(57) Abstract</p> <p>An absorbent structure in an absorbent article such as a diaper, incontinence guard, sanitary napkin, wound dressing, bed protection and the like, formed from at least two superposed layers (5'; 5'') of one or more web-shaped absorption materials (5), said layers (5'; 5'') having different widths as seen in the transverse direction of the article. The absorbent structure (4) comprised of said layers has been compressed to a thickness which is substantially the same over the width of the structure, in such a way that the structure has a higher density in the areas thereof where the layers overlap each other and a lower density in other areas.</p>		

FOR THE PURPOSES OF INFORMATION ONLY

Codes used to identify States party to the PCT on the front pages of pamphlets publishing international applications under the PCT.

AL	Albania	ES	Spain	LS	Lesotho	SI	Slovenia
AM	Armenia	FI	Finland	LT	Lithuania	SK	Slovakia
AT	Austria	FR	France	LU	Luxembourg	SN	Senegal
AU	Australia	GA	Gabon	LV	Latvia	SZ	Swaziland
AZ	Azerbaijan	GB	United Kingdom	MC	Monaco	TD	Chad
BA	Bosnia and Herzegovina	GE	Georgia	MD	Republic of Moldova	TG	Togo
BB	Barbados	GH	Ghana	MG	Madagascar	TJ	Tajikistan
BE	Belgium	GN	Guinea	MK	The former Yugoslav Republic of Macedonia	TM	Turkmenistan
BF	Burkina Faso	GR	Greece			TR	Turkey
BG	Bulgaria	HU	Hungary	ML	Mali	TT	Trinidad and Tobago
BJ	Benin	IE	Ireland	MN	Mongolia	UA	Ukraine
BR	Brazil	IL	Israel	MR	Mauritania	UG	Uganda
BY	Belarus	IS	Iceland	MW	Malawi	US	United States of America
CA	Canada	IT	Italy	MX	Mexico	UZ	Uzbekistan
CF	Central African Republic	JP	Japan	NE	Niger	VN	Viet Nam
CG	Congo	KE	Kenya	NL	Netherlands	YU	Yugoslavia
CH	Switzerland	KG	Kyrgyzstan	NO	Norway	ZW	Zimbabwe
CI	Côte d'Ivoire	KP	Democratic People's Republic of Korea	NZ	New Zealand		
CM	Cameroon			PL	Poland		
CN	China	KR	Republic of Korea	PT	Portugal		
CU	Cuba	KZ	Kazakstan	RO	Romania		
CZ	Czech Republic	LC	Saint Lucia	RU	Russian Federation		
DE	Germany	LI	Liechtenstein	SD	Sudan		
DK	Denmark	LK	Sri Lanka	SE	Sweden		
EE	Estonia	LR	Liberia	SG	Singapore		

ABSORBENT STRUCTURE

Technical field

The present invention refers to an absorbent structure in an absorbent article such as a
5 diaper, incontinence guard, sanitary napkin, wound dressing, bed protection and the
like, formed from at least two superposed layers of one or more web-shaped absorption
materials. The invention further refers to a method for manufacturing the absorbent
structure.

10 *Background of the invention*

Many different types of absorbent structures in absorbent articles of the above
mentioned kind are previously known. They usually consist of one or more compressed
layer of cellulosic fluff pulp, often in combination with so called superabsorbents,
which are polymers with the capacity to absorb water or body liquids many times their
15 own weight. Other types of absorbent structures are airlaid cellulosic fibrous webs
which have been bound with a bonding agent, e.g. latex, heat meltable bonding fibers or
the like, dry formed reel pulp according to WO 90/0508, absorbent foam materials etc.

The body liquid is discharged to the absorbent article in a very limited area, the so
20 called wetting point. It shall from there be distributed further to unutilized portions of
the absorbent structure. Above all it is desired to have a distribution of liquid in the
longitudinal direction of the article, while spreading towards the longitudinal edges can
give edge leakage, which should be avoided. In order to enhance the liquid distribution
in the longitudinal direction it is known to have special distribution layers in the
25 absorbent article and/or to compress this in patterns in the form of longitudinal
compression lines, along which the liquid can be easily distributed.

Through EP 0 481 322 there is known an absorbent structure made from a web-shaped
absorption material which in its initial position has an even density and thickness in the
30 xy-direction and which has been compressed to a higher density and by that a lower
thickness in certain areas. The material is then folded together to form at least two

layers which have different densities. In this way an absorbent structure having different densities in the z-direction can be produced.

Object and most important features of the invention

5 The object of the present invention is to provide an absorbent structure in an absorbent article of the above mentioned kind, in which it in a simple way is possible to create areas of different densities in the xy-direction of the structure. This has according to the invention been provided by the fact that the structure comprises at least two superposed layers of one or more web-shaped absorption materials, said layers having different
10 widths as seen in the cross direction of the article and that the absorbent structure comprised of said layers has been compressed to a thickness which is substantially the same over the width of the structure, in such a way that the structure has a higher density in the areas thereof where the layers overlap each other and a lower density in other areas.

15 The layers can either be formed from one and the same web-shaped absorption materials which have been folded to the desired configuration or alternatively be formed from separate pieces of the web-shaped material, which either can be the same in the different layers or different.

20 The invention further refers to a method for manufacturing an absorbent article, at which at least two layers of one or more web-shaped absorption materials are placed superposed to each other, said layers having different widths as seen in the transverse direction of the article and that the absorbent structure comprised of said layers is
25 compressed to a thickness which is substantially the same over the width of the structure, in such a way that the structure will have a higher density in the areas thereof where the layers overlap each other and a lower density in other areas.

30 Further features of the invention are disclosed in the following description and from the claims.

Description of the drawings

The invention will in the following be closer described with reference to some embodiments shown in the accompanying drawings.

Fig. 1 shows in a view from above an absorbent article in the form of a sanitary napkin.

5 Fig. 2 is a section according to the line II-II in Fig.1.

Fig. 3 shows schematically an irregularly folded absorption material forming the start point for an absorbent structure according to the invention.

Fig. 4 shows schematically strips of a web-shaped absorption material of different widths placed superposed to each other and forming the start point for an absorbent structure according to the invention.

10 Fig. 5 shows schematically an absorbent structure with different densities in different areas obtained by compressing the material shown in Fig. 3 or Fig. 4.

Description of embodiments

15 Fig. 1 and 2 shows an embodiment of a sanitary napkin 1 comprising a liquid pervious topsheet 2, a liquid impervious backsheets 3 and an absorbent body 4 arranged therebetween. Further layers be included, such as liquid acquisition layers, distribution layers etc.

20 It should be pointed out that the sanitary napkin shown in the drawings only constitutes a non-limiting example of an absorbent article. Thus the shape and construction of the article may vary. The absorbent article can also consist of a diaper, a pant diaper, an incontinence guard, a wound dressing, a bed protection and the like.

25 The liquid pervious topsheet 2 may consist of a nonwoven material, for example a spunbond material of synthetic filament, a meltblown material, a thermobonded material or a bonded carded fibrous web. Alternatively it may consist of a perforated plastic film or a perforated laminate of nonwoven or plastic film.

The liquid pervious backsheet 3 may consist of a plastic film, a nonwoven material which is coated with a liquid impervious material or a hydrophobic nonwoven material which resists liquid penetration.

5 On the underside of the liquid impervious backsheet 3 fastening means in the form of longitudinal strings 6 of adhesive glue are provided. The glue areas are preferably before use covered with a releasable protective strip (not shown) of paper or plastic film treated with a release agent. In the shown embodiment the fastening means consist of longitudinal glue areas. A plurality of other glue patterns, e g crosswise, are of course
10 possible as well as other types of fastening means such as Velcro-type, press buttons, girdles, special underpants and the like.

The sanitary napkin in the shown embodiments is hourglass shaped with broader end portions 7 and a narrow crotch portion 8. The crotch portion 8 is the portion of the
15 sanitary napkin which during use is intended to be placed in the crotch area of the user and serve as a receiving surface for the discharged body fluid.

The topsheet 2 and the backsheet 3 have a somewhat larger extension in the plane of the absorbent body 4 and extend outside the edges thereof. The layers 2 and 3 are
20 interconnected within the projecting portions, e g by gluing or welding with ultrasonic or heat.

The absorbent body 4 can be of an optional web-shaped absorption material 5, such as airlaid cellulosic fibers which have been bonded with a bonding agent, e g latex, heat
25 meltable bonding fibers or the like, dry-formed reel pulp according to WO 90/0508, sheets of absorbent foam material etc. A certain amount of superabsorbent material may possibly be incorporated in the absorption material.

The absorption material 5 according to the embodiment shown in Fig. 3 is irregularly
30 folded in zigzag-shape along five folding lines, in such a way that six layers 5' are formed which have different widths. The outer of these layers 5' have the smallest

width while the innermost layers have the largest width. The configuration of the irregular folding can of course be varied in many different ways, of which the shown only is one example. The irregularly folded web-shaped absorption material forms the start point for the production of the absorbent structure according to the invention.

5

In the embodiment shown in Fig. 4 three separate strips 5'' of a web-shaped absorption material have been placed in superposed relationship. These strips have three different widths and can be of the same or of different web-shaped absorption materials. Besides they have different lengths.

10

Upon compressing any of the materials composed of several layers according to Fig. 3 or 4 to an even thickness the portions that consist of the most layers will have a density which is higher than that of the portions that consist of fewer layers. In the shown embodiments the middle portion 9 will have the highest density and the immediately outside said middle portion located side portions 10 will have a higher density, while the outermost edge portions 11 will have the lowest density.

20

Since liquid is more rapidly distributed in smaller capillaries, which means a more rapid distribution with an increased density, the liquid will at first hand be distributed along the hardest compressed middle portion 9, while the outside this located portions 10 and 11 will serve as a kind of safety zones, which mainly are utilized when the middle portion is saturated with liquid. With such a construction of the absorbent article edge leakage from the longitudinal edges of the article can be minimized. If the layers also have different lengths as is shown in Fig. 4, the risk for edge leakage from the transverse edges of the article is also minimized.

25

The different material layers can be compressed together in a pattern for forming longitudinal compression lines, at which the liquid distribution in the longitudinal direction is further improved.

30

Claims

1. An absorbent structure in an absorbent article such as a diaper, incontinence guard, sanitary napkin, wound dressing, bed protection and the like, formed from at least two superposed layers (5';5'') of one or more web-shaped absorption materials (5),
5 characterized in
that said layers (5':5'') of the web-shaped absorption material(-s) (5) have different widths as seen in the cross direction of the article and that the absorbent structure (4) comprised of said layers has been compressed to a thickness which is substantially the
10 same over the width of the structure, in such a way that the structure has a higher density in the areas thereof where the layers overlap each other and a lower density in other areas.
2. Absorbent structure according to claim 1,
15 characterized in
that said layers (5') are formed from one and the same web-shaped absorption materials (5) which has been folded to the desired configuration.
3. Absorbent structure according to claim 2,
20 characterized in
that the web-shaped absorption material is folded in zigzag-shape in such a way that the structure in a middle portion (9) comprises more layers than in the longitudinal edge portions (11), at which the structure has a higher density in the middle portion than in the edge portions.
- 25
4. Absorbent structure according to claim 1,
characterized in
that said layers (5'') are formed from separated strips of the web-shaped absorption material(-s).
- 30

5. Absorbent structure according to claim 4,
c h a r a c t e r i z e d i n
that said separate strips have different widths and are placed in superposed relationship
in such a way that the structure in a middle portion (9) comprises more layers than in
5 the longitudinal edge portions (11), at which the structure has a higher density in the
middle portion than in the edge portions.

6. Absorbent structure according to claims 4 or 5,
c h a r a c t e r i z e d i n
10 that different types of absorption materials are used in the different layers (5'').

7. Absorbent structure according to any of the preceding claims,
c h a r a c t e r i z e d i n
that said layers (5';5'') of the web-shaped absorption material(-s) (5) also have
15 different lengths as seen in the longitudinal direction of the article.

8. Absorbent article such as a diaper, incontinence guard, sanitary napkin, wound
dressing, bed protection and the like of the kind comprising a liquid pervious topsheet
(1), a liquid impervious backsheet (2) and an absorbent structure (4) arranged
20 therebetween,
c h a r a c t e r i z e d i n
that the absorbent structure (4) is of a kind stated in any of claims 1-7.

9. Method for making an absorbent structure in an absorbent article such as a diaper,
25 incontinence guard, sanitary napkin, wound dressing, bed protection and the like, at
which at least two layers (5';5'') of one or more web-shaped absorption materials are
placed superposed to each other,
c h a r a c t e r i z e d i n
that said layers (5';5'') of the web-shaped absorption material(-s) have different widths
30 as seen in the transverse direction of the article and that the absorbent structure (4)
comprised of said layers is compressed to a thickness which is substantially the same

over the width of the structure, in such a way that the structure will have a higher density in the areas thereof where the layers overlap each other and a lower density in other areas.

5 10. Method as claimed in claim 9,
c h a r a c t e r i z e d i n
that the web-shaped absorption material (5) is folded to the desired configuration for forming said layers (5'), after which compression to a substantially even thickness takes place.

10 11. Method as claimed in claim 10,
c h a r a c t e r i z e d i n
that the web-shaped absorption material is folded in zigzag-shape in such a way that the structure in a middle portion (9) will comprise more layers than in the longitudinal edge
15 portions (11), and that then the structure is compressed to an essentially even thickness at which it will have a higher density in the middle portion than in the edge portions.

12. Method as claimed in claim 9,
c h a r a c t e r i z e d i n
20 that at least two separate pieces of the web-shaped absorption material(-s) of different widths are placed superposed to each other for forming said layers (5'), after which compression to an essentially even thickness takes place.

13. Method as claimed in claim 12,
25 c h a r a c t e r i z e d i n
that said separate strips are placed on each other in such a way that the structure in a middle portion (9) comprises more layers than in the longitudinal edge portions (11), at which the structure is given a higher density in the middle portion than in the edge portions after compression to an essentially even thickness.

30

14. Method as claimed in claim 12 or 13,
c h a r a c t e r i z e d i n
that different types of absorption materials are used in the different layers (5'').

1/2

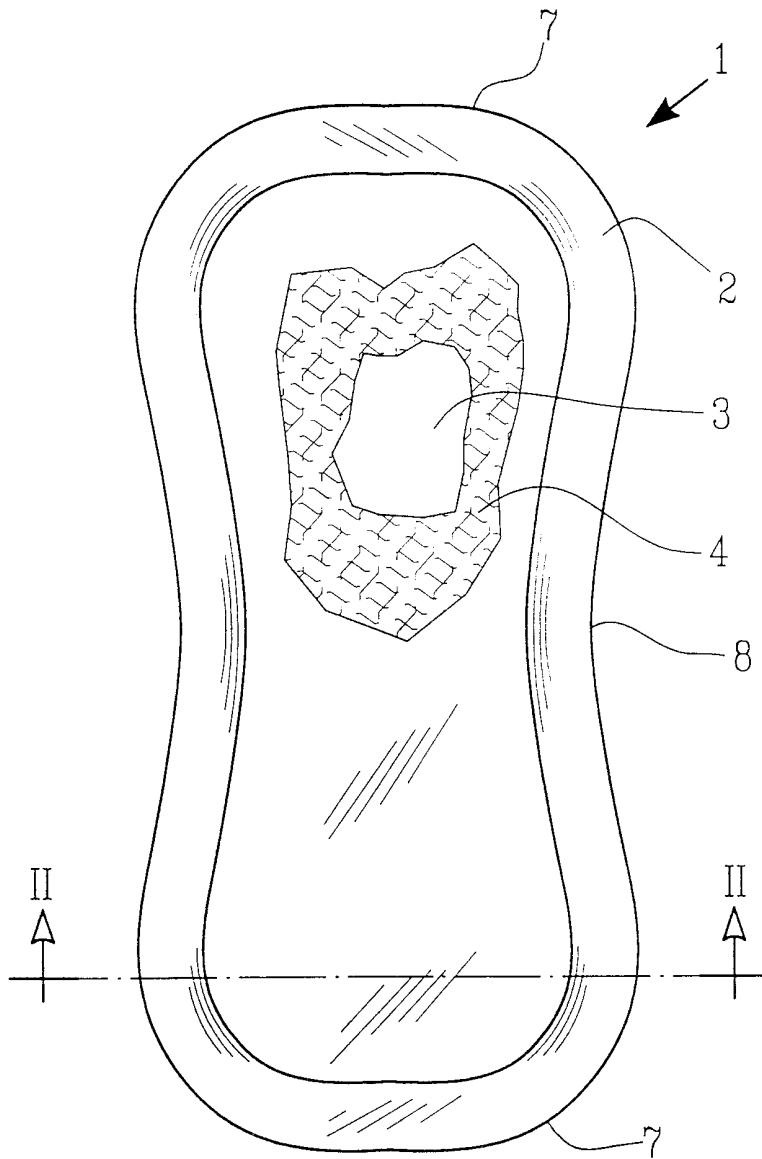

FIG. 1

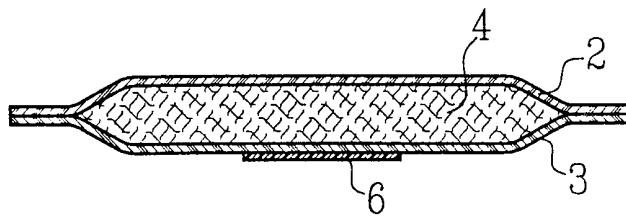

FIG. 2

2/2

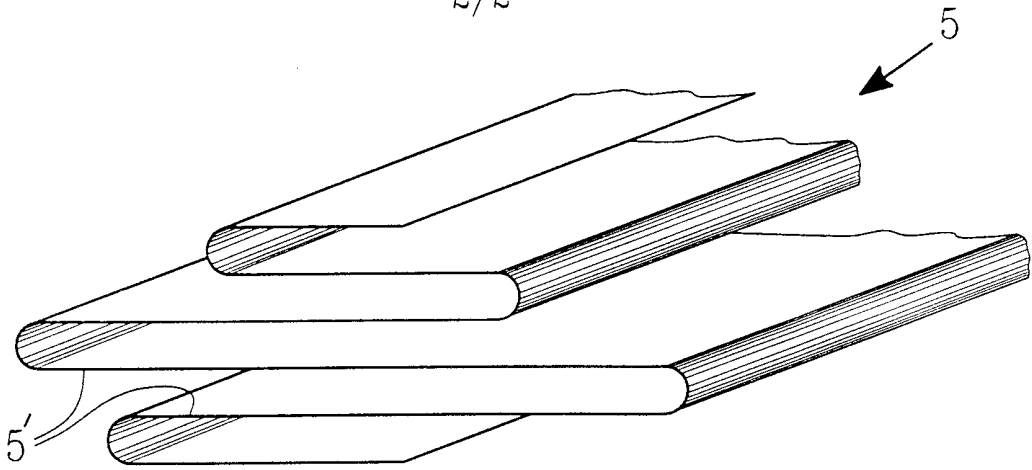

FIG. 3

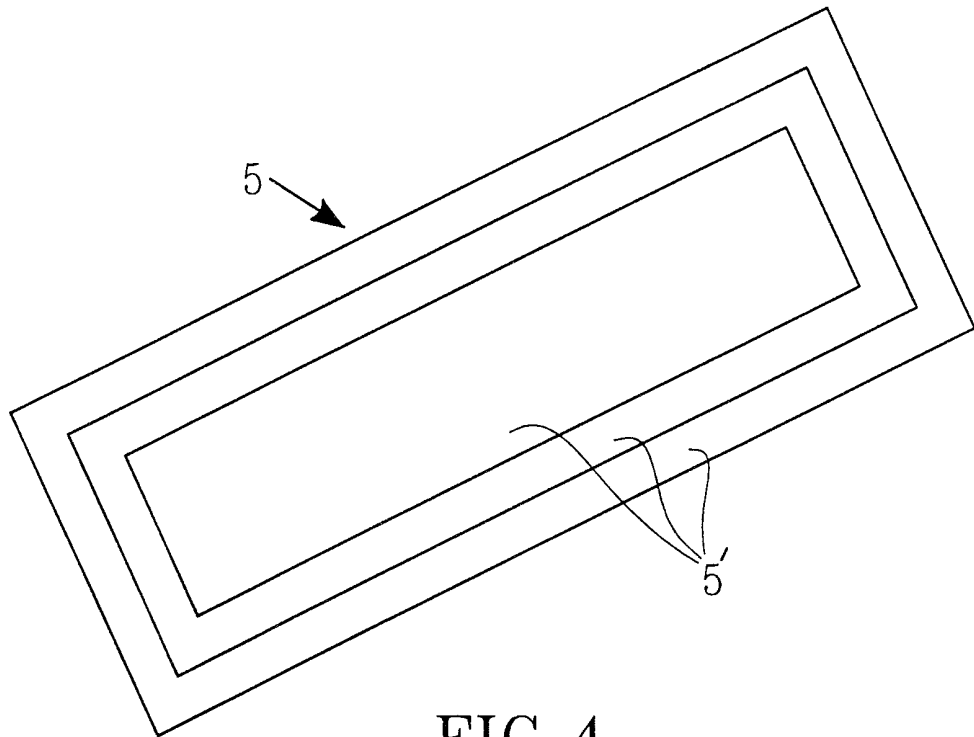

FIG. 4

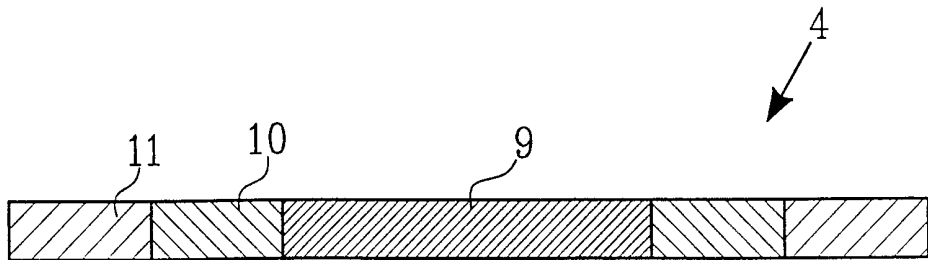

FIG. 5

INTERNATIONAL SEARCH REPORT

International application No.
PCT/SE 99/00964

A. CLASSIFICATION OF SUBJECT MATTER

IPC6: A61F 13/15

According to International Patent Classification (IPC) or to both national classification and IPC

B. FIELDS SEARCHED

Minimum documentation searched (classification system followed by classification symbols)

IPC6: A61F

Documentation searched other than minimum documentation to the extent that such documents are included in the fields searched

SE,DK,FI,NO classes as above

Electronic data base consulted during the international search (name of data base and, where practicable, search terms used)

C. DOCUMENTS CONSIDERED TO BE RELEVANT

Category*	Citation of document, with indication, where appropriate, of the relevant passages	Relevant to claim No.
Y	US 3865112 A (ROEDER), 11 February 1975 (11.02.75), column 1, line 61 - column 2, line 44, figure 1, abstract --	1-3,9-11
Y	US 4027672 A (KARAMI), 7 June 1977 (07.06.77), column 1, line 59 - column 2, line 30, figures 5a, 5b, claim 17, abstract --	1-3,9-11
A	SE 427985 B (PIERRE FRANCO), 30 May 1983 (30.05.83), page 3, line 25 - line 28 --	1-14
A	US 5807365 A (LUCERI), 15 Sept 1998 (15.09.98), abstract --	1-14



Further documents are listed in the continuation of Box C.



See patent family annex.

* Special categories of cited documents:

"A" document defining the general state of the art which is not considered to be of particular relevance

"E" earlier document but published on or after the international filing date

"L" document which may throw doubts on priority claim(s) or which is cited to establish the publication date of another citation or other special reason (as specified)

"O" document referring to an oral disclosure, use, exhibition or other means

"P" document published prior to the international filing date but later than the priority date claimed

"T" later document published after the international filing date or priority date and not in conflict with the application but cited to understand the principle or theory underlying the invention

"X" document of particular relevance: the claimed invention cannot be considered novel or cannot be considered to involve an inventive step when the document is taken alone

"Y" document of particular relevance: the claimed invention cannot be considered to involve an inventive step when the document is combined with one or more other such documents, such combination being obvious to a person skilled in the art

"&" document member of the same patent family

Date of the actual completion of the international search

5 October 1999

Date of mailing of the international search report

11 -10- 1999

Name and mailing address of the ISA/

Swedish Patent Office
Box 5055, S-102 42 STOCKHOLM
Facsimile No. +46 8 666 02 86

Authorized officer

Tomas Gustafsson/EÖ
Telephone No. +46 8 782 25 00

INTERNATIONAL SEARCH REPORT

International application No.

PCT/SE 99/00964

C (Continuation). DOCUMENTS CONSIDERED TO BE RELEVANT

Category*	Citation of document, with indication, where appropriate, of the relevant passages	Relevant to claim No.
A	US 5649916 A (DIPALMA ET AL), 22 July 1997 (22.07.97), figure 2, abstract --	1-14
A	EP 0481322 A1 (KIMBERLY-CLARK CORPORATION), 22 April 1992 (22.04.92), abstract -- -----	1-14

INTERNATIONAL SEARCH REPORT
Information on patent family members

30/08/99

International application No.
PCT/SE 99/00964

Patent document cited in search report	Publication date	Patent family member(s)	Publication date
US 3865112 A	11/02/75	NONE	

US 4027672 A	07/06/77	AT 363420 B	10/08/81
		AT 929076 A	15/01/81
		AU 512002 B	18/09/80
		AU 2051876 A	22/06/78
		BE 849960 A	15/04/77
		BR 7608700 A	25/10/77
		CA 1092331 A	30/12/80
		CH 609539 A	15/03/79
		DE 2656482 A,C	07/07/77
		DK 149563 B,C	28/07/86
		DK 576576 A	30/06/77
		FR 2336916 A,B	29/07/77
		GB 1502588 A	01/03/78
		GR 63686 A	29/11/79
		IE 44272 B	23/09/81
		IT 1073596 B	17/04/85
		JP 1344099 C	29/10/86
		JP 52084040 A	13/07/77
		JP 61003882 B	05/02/86
		NL 7614205 A	01/07/77
		PH 12390 A	29/01/79
		PT 65984 A,B	01/01/77
		ZA 7607288 A	26/07/78

SE 427985 B	30/05/83	BE 853933 A	25/10/77
		BR 7702588 A	17/01/78
		CA 1115452 A	05/01/82
		CH 611154 A	31/05/79
		DE 2718344 A,C	22/12/77
		FR 2354753 A,B	13/01/78
		GB 1560151 A	30/01/80
		IT 1077107 B	04/05/85
		JP 52152694 A	19/12/77
		NL 182367 B,C	01/10/87
		NL 7704498 A	16/12/77
		SE 7704751 A	15/12/77
		US 4184498 A	22/01/80

INTERNATIONAL SEARCH REPORT

Information on patent family members

30/08/99

International application No.

PCT/SE 99/00964

Patent document cited in search report	Publication date	Patent family member(s)	Publication date
US 5807365 A	15/09/98	AT 167622 T	15/07/98
		AU 679689 B	10/07/97
		AU 4900793 A	28/04/94
		CA 2108310 A	15/04/94
		DE 69319303 D,T	22/10/98
		EP 0597273 A,B	18/05/94
		SE 0597273 T3	
		ES 2119845 T	16/10/98
		FI 934518 A	15/04/94
		GR 1003071 B	12/02/99
		GR 93100405 A	30/06/94
		NO 933687 A	15/04/94
		US 5649916 A	22/07/97
AU 3140595 A	22/03/96		
BR 9508657 A	12/08/97		
CA 2197494 A	07/03/96		
CN 1156957 A	13/08/97		
CZ 9700588 A	11/06/97		
EP 0778763 A	18/06/97		
JP 10505262 T	26/05/98		
WO 9606591 A	07/03/96		
EP 0481322 A1	22/04/92		
		AU 7609491 A	16/04/92
		DE 69115430 D,T	02/05/96
		ES 2082904 T	01/04/96
		MX 9101268 A	01/01/93
		US 5611879 A	18/03/97
		AU 636796 B	06/05/93
		AU 8462291 A	26/11/92
		CA 2050022 A	16/10/92