

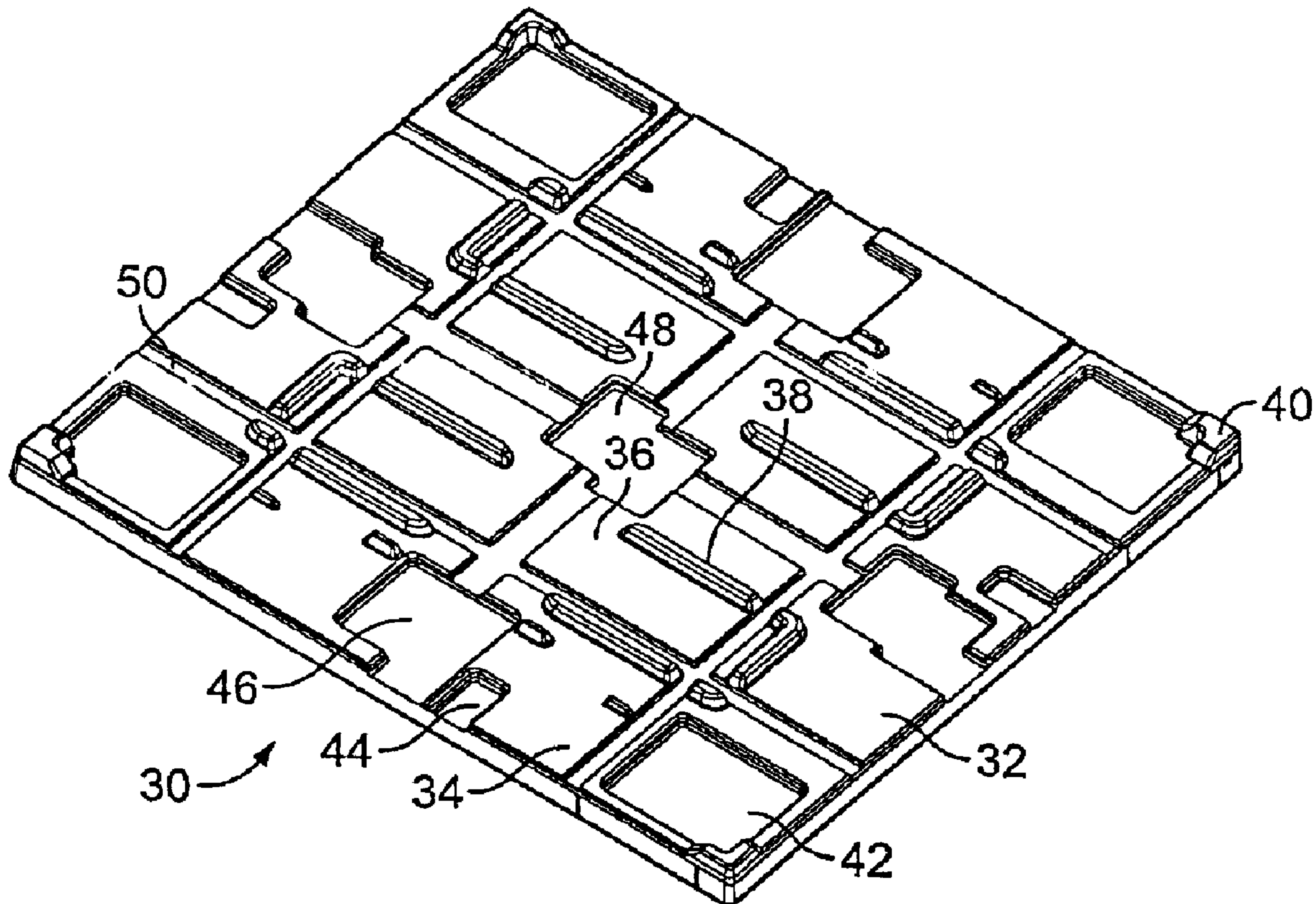

(22) Date de dépôt/Filing Date: 2009/02/27
(41) Mise à la disp. pub./Open to Public Insp.: 2009/08/28
(30) Priorité/Priority: 2008/02/28 (US12/039,293)

(51) Cl.Int./Int.Cl. *B65D 19/38* (2006.01),
B65D 21/00 (2006.01)
(71) Demandeur/Applicant:
ORBIS CORPORATION, US
(72) Inventeur/Inventor:
BANIK, JOACHIM, US
(74) Agent: BCF LLP

(54) Titre : COIFFE SOMMITALE
(54) Title: TOP CAP



(57) Abrégé/Abstract:

A top cap designed to allow any of a pallet, a bulk bin and a metal rack, each having a different support configuration, or any of a nestable pallet and a bulk bin, to stack securely on an upper surface of the top cap. The top cap including a plurality of raised



(57) **Abrégé(suite)/Abstract(continued):**

and/or indented portions on the upper surface configured to mate with a bottom surface of the pallet, bulk bin or metal rack. The top cap also being configured to allow other pallets, bulk bins, or metal racks to stack securely on the upper surface of the top cap. The top cap being formed from a molded plastic material.

ABSTRACT OF THE INVENTION

A top cap designed to allow any of a pallet, a bulk bin and a metal rack, each having a different support configuration, or any of a nestable pallet and a bulk bin, to stack securely on an upper surface of the top cap. The top cap including a plurality of raised and/or indented portions on the upper surface configured to mate with a bottom surface of the pallet, bulk bin or metal rack. The top cap also being configured to allow other pallets, bulk bins, or metal racks to stack securely on the upper surface of the top cap. The top cap being formed from a molded plastic material.

TOP CAP**DESCRIPTION**Cross-Reference to Related Applications

[0001] The application for the present invention is being filed concurrently with U.S. Design Patent Application No. 29/304,294 [Attorney Docket No.: 52045-3202].

Federally Sponsored Research or Development

[0002] Not Applicable.

Technical Field

[0003] The invention relates to a top cap having an upper surface configured to securely mate with the footprint of all of one or more pallet designs, one or more bulk bin designs and one or more metal rack designs; or all of one or more nestable pallet designs with one or more bulk bin designs and/or one more metal rack designs.

Background of the Invention

[0004] Goods and other items are transported utilizing a variety of containers and other packaging or transportation systems. Such packaging or transportation systems can include pallets, bulk bins, metal racks, etc. In some instances, a top cap is utilized as part of one or more of these systems. The top cap allows for securing a second load of product on top of a lower load through either a pallet, bulk bin or rack. The top cap also protects the top (or top of the top row) of the goods during shipping.

[0005] In some cases, it may be necessary to stack one packaging system carrying goods or other items onto another. This may be done to make the most efficient use of the cargo hold of a ship, intermodal or truck.

[0006] In situations where packaging systems are stacked on top of one another, it is necessary to insure that the system on top is securely positioned on the lower system. Otherwise, the upper system could become unstable and possibly injure someone below and/or damage the goods or other items being shipped.

[0007] Each type of packaging system has its own bottom or lower structure which defines a footprint or support configuration. Moreover, different configurations can be found within a particular footprint. For example, there can be several styles of bulk bins or pallets in the same footprint, each having its own configuration.

[0008] One class of a packaging system - plastic pallets – are typically categorized as either stackable or nestable. As used herein, a stackable pallet includes one or more stringer which define a flat bottom surface (stringers may vary in configuration). The bottom surface of a stackable pallet rests on the deck of a pallet below it when stacked. In contrast, as used herein, a nestable pallet includes a plurality of legs. When stacked on a like pallet, the legs will descend into the leg pockets of the pallet below resulting in a greater nest ratio than stackable pallets.

[0009] Known top caps have been designed to mate with nestable pallets, to enable the nestable pallet to be securely positioned on the top cap. However, such top caps would not work with other systems. Similarly, some top caps have been separately designed to mate with only bulk bins, or only the combination of bulk bins and stackable pallets having a similar footprint.

[0010] While these systems are useful, it is desirable to be able to stack different types or combinations of systems utilizing the same top cap. This ability would facilitate stacking of various forms of packaging without requiring a selection of the correct top cap.

[0011] The present invention is provided to solve the problems discussed and to provide advantages and aspects not provided by prior top caps of this type. A full discussion of the features and advantages of the present invention is deferred to the following detailed description, which proceeds with reference to the accompanying drawings.

Summary of the Invention

[0012] The present invention provides a top cap designed to allow a variety of different packaging systems to be securely stacked onto the top surface of the top cap. The systems can include one or more different pallet designs, one or more different bulk bin designs, and one or more different metal rack designs. Moreover, the top cap is also configured to nest with other top caps of the same type, as well as certain top caps having a different design.

[0013] The top cap has a generally rectangular or square shape, and is formed in a sheet having a variety of structure on both an upper or top surface and a lower or bottom surface. Specifically, the upper surface is contoured to capture or mate with the bottom surface or footprint of the various pallets, bulk bins and metal racks. The lower surface preferably includes a plurality of ribs extending downwardly from a planar portion. The

ribs provide stiffness and support without significantly increasing the weight of the top cap.

[0014] In accordance with one aspect of the invention, the top cap is specifically configured to include an upper surface designed to mate with the bottom surface or structure (i.e., footprint) of each of one or more pallet designs, one or more bulk bin designs and one or more metal rack designs. In other words, a pallet or a bulk bin or a metal rack could be stacked on the top cap as desired. The bottom surface for each design forms a footprint that matches with corresponding structure on the top surface of the top cap. The structure on the top surface of the top cap will appear as raised and/or indented portions, such as ridges and other similar structures. In some instances, a portion of the structure on the top surface used to mate with the footprint of one system (e.g., a first pallet design) may also be used with other structure on the top surface to mate with the footprint of another system (e.g., a first bulk bin design or a first metal rack design). The designs within a particular group of systems (e.g., pallets) can be similar or have differences.

[0015] In accordance with another aspect of the invention, a top cap is provided comprising a generally rectangular sheet having a lower surface and an upper surface. The upper surface is contoured to securely mate with the bottom surface of a first nestable pallet, the bottom surface of a first bulk bin, and the bottom surface of a metal rack.

[0016] The contour of the upper surface can also be configured to mate with other pallet or bulk bin designs having different bottom surfaces or footprints than the first pallet and first bulk bin. Additionally, the upper surface can be contoured to securely mate with the bottom surface of a first metal rack, as well as other metal racks.

[0017] In accordance with yet another aspect of the invention, a top cap is provided that comprises a first upper surface configured to securely mate with any of a footprint of a first pallet design, a footprint of a first bulk bin design, and a footprint of a first metal rack design. That is, the top cap allows for any of these systems to be securely stacked on the top cap.

[0018] The top cap also includes a second surface opposing the first surface for contacting one or more items being transported. The second surface can include a plurality of ribs projecting away from the second surface.

[0019] In addition to being configured to securely mate with a first pallet, bulk bin and metal rack, the first surface of the top cap can be further configured to mate with one or

more of a footprint of a second pallet design different than the footprint of the first pallet design, a footprint of a second bulk bin design different than the footprint of the first bulk bin design, or a footprint of a second metal rack design different than the footprint of the first metal rack design.

[0020] The top cap can include a set of raised portions on the first surface positioned to mate with the bottom surface or structure defining the footprint of the first pallet.

Similarly, the top cap can include a set of raised portions on the first surface positioned to mate with the bottom surface or structure defining the footprint of the first bulk bin, and a set of raised portions on the first surface positioned to mate with the bottom surface or structure defining the footprint of the first metal rack.

[0021] The top cap can be formed from a plastic or other similar or suitable material. For example, the top cap could be an injection molded plastic, or a structural foam. The top cap can be formed under high pressure or as a thermoform.

[0022] The top caps disclosed herein can be configured to nest with one of another same model top cap or a different model top cap.

[0023] In accordance with another aspect of the invention, a plastic top cap is provided for use in transporting goods which is configured for facilitating stacking of other transportation components. The top cap comprises an upper surface having a generally rectangular shape. The upper surface includes a first plurality of raised portions configured to securely capture the bottom surface or structure of a first pallet having a first pallet footprint design, a second plurality of raised portions configured to securely capture the bottom surface or structure of a first bulk bin having a first bulk bin footprint design; and a third plurality of raised portions configured to securely capture the bottom surface or structure of a first metal rack having a first metal rack footprint design.

[0024] Additionally, the top cap can further comprise a plurality of raised portions configured to capture the bottom surface or structure of a second pallet having a second pallet footprint design different than the first pallet footprint design. Similarly, the top cap can include a plurality of raised portions configured to capture the bottom surface or structure of a second bulk bin having a second bulk bin footprint design different than the first bulk bin footprint design or a plurality of raised portions configured to capture the bottom surface or structure of a second metal rack having a second metal rack footprint design different than the first metal rack footprint design.

[0025] The plastic top cap further comprises a second side for contacting items being transported. The second side can include a plurality of downwardly extending ribs.

[0026] The top cap can be configured to securely stack with another top cap. The other top cap can be of the same type or in some instances, a different model top cap.

[0027] In accordance with yet another aspect of the invention, a top cap is provided which comprises a top surface having raised portions configured to securely mate with a plurality of different pallet designs; a plurality of different bulk bin designs and a plurality of different metal rack designs.

[0028] Other features and advantages of the invention will be apparent from the following specification taken in conjunction with the following drawings.

Brief Description of the Drawings and Attachments

[0029] To understand the present invention, it will now be described by way of example, with reference to the accompanying drawings in which:

[0030] FIG. 1 is a perspective view of an embodiment of a top cap having an upper surface configured to stack with other systems in accordance with the present invention;

[0031] FIG. 2 is a perspective view of another embodiment of a top cap having an upper surface configured to stack with other systems in accordance with the present invention;

[0032] FIGs. 3A and 3B are a bottom plan view and a perspective view, respectively, of the bottom surface or structure of a first pallet design that can be stacked on the top caps of the present invention;

[0033] FIGs. 4A and 4B are a bottom plan view and a perspective view, respectively, of the bottom surface or structure of a second pallet design that can be stacked on the top caps of the present invention;

[0034] FIGs. 5A and 5B are a bottom plan view and a perspective view, respectively, of the bottom surface or structure of a third pallet design that can be stacked on the top caps of the present invention;

[0035] FIGs. 6A and 6B are a bottom plan view and a perspective view, respectively, of the bottom surface or structure of a fourth pallet design that can be stacked on the top caps of the present invention;

[0036] FIGs. 7A and 7B are a bottom plan view and a perspective view, respectively, of the bottom surface or structure of a fifth pallet design that can be stacked on the top caps of the present invention;

[0037] FIGs. 8A and 8B are a bottom plan view and a perspective view, respectively, of the bottom surface or structure of a sixth pallet design that can be stacked on the top caps of the present invention;

[0038] FIGs. 9A and 9B are a bottom plan view and a perspective view, respectively, of the bottom surface or structure of a first bulk bin design that can be stacked on the top caps of the present invention;

[0039] FIGs. 10A and 10B are a bottom plan view and a perspective view, respectively, of the bottom surface or structure of a second bulk bin design that can be stacked on the top caps of the present invention;

[0040] FIGs. 11A and 11B are a bottom plan view and a perspective view, respectively, of the bottom surface or structure of a third bin design that can be stacked on the top caps of the present invention;

[0041] FIGs. 12A and 12B are a bottom plan view and a perspective view, respectively, of the bottom surface or structure of a fourth bulk bin design that can be stacked on the top caps of the present invention;

[0042] FIGs. 13A and 13B are a perspective view and a bottom plan view, respectively, of the bottom surface or structure of a first metal rack design that can be stacked on the top caps of the present invention;

[0043] FIGs. 14A and 14B are a perspective view and a bottom plan view, respectively, of another model top cap that can nest with the top caps of the present invention;

[0044] FIGs. 15A and 15B are a side by side view of the top caps of FIGs. 1 and 2 showing placement of the bottom surface or structure of the pallet of FIGs. 3A and 3B in phantom;

[0045] FIGs. 16A and 16B are a side by side view of the top caps of FIGs. 1 and 2 showing placement of the bottom surface or structure of the pallet of FIGs. 4A and 4B in phantom;

[0046] FIGs. 17A and 17B are a side by side view of the top caps of FIGs. 1 and 2 showing placement of the bottom surface or structure of the pallet of FIGs. 5A and 5B in phantom;

[0047] FIGs. 18A and 18B are a side by side view of the top caps of FIGs. 1 and 2 showing placement of the bottom surface or structure of the pallet of FIGs. 6A and 6B in phantom;

[0048] FIGs. 19A and 19B are a side by side view of the top caps of FIGs. 1 and 2 showing placement of the bottom surface or structure of the pallet of FIGs. 7A and 7B in phantom;

[0049] FIGs. 20A and 20B are a side by side view of the top caps of FIGs. 1 and 2 showing placement of the bottom surface or structure of the pallet of FIGs. 8A and 8B in phantom;

[0050] FIGs. 21A and 21B are a side by side view of the top caps of FIGs. 1 and 2 showing placement of the bottom surface or structure of the bulk bin of FIGs. 9A and 9B in phantom;

[0051] FIGs. 22A and 22B are a side by side view of the top caps of FIGs. 1 and 2 showing placement of the bottom surface or structure of the bulk bin of FIGs. 10A and 10B in phantom;

[0052] FIGs. 23A and 23B are a side by side view of the top caps of FIGs. 1 and 2 showing placement of the bottom surface or structure of the bulk bin of FIGs. 12A and 12B in phantom;

[0053] FIGs. 24A and 24B are a side by side view of the top caps of FIGs. 1 and 2 showing placement of the bottom surface or structure of the bulk bin of FIGs. 29A and 29B in phantom;

[0054] FIGs. 25A and 25B are a side by side view of the top caps of FIGs. 1 and 2 showing placement of the bottom surface or structure of the bulk bin of FIGs. 11A and 11B in phantom;

[0055] FIGs. 26A and 26B are a side by side view of the top caps of FIGs. 1 and 2 showing placement of the bottom surface or structure of the metal rack of FIGs. 13A and 13B in phantom;

[0056] FIG. 27 is a perspective view of the bottom of the top cap of FIG. 2;

[0057] FIG. 28 a perspective view of another embodiment of a top cap having an upper surface configured to stack with other systems in accordance with the present invention; and,

[0058] FIGs. 29A and 29B are a bottom plan view and a perspective view, respectively, of the bottom surface or structure of a fifth bulk bin design that can be stacked on the top caps of the present invention.

Detailed Description

[0059] While this invention is susceptible of embodiments in many different forms, there is shown in the drawings and will herein be described in detail preferred embodiments of the invention with the understanding that the present disclosure is to be considered as an exemplification of the principles of the invention and is not intended to limit the broad aspect of the invention to the embodiments illustrated.

[0060] Referring to Figure 1, a first top cap design 10 in accordance with the present invention is provided. The top cap 10 has a generally rectangular or square outline or shape (preferably dimensioned as 45x48 inches) and includes a top surface 12. The top cap 10 is preferably formed from a molded plastic.

[0061] The top surface 12 of the top cap 10 includes structure to mate with or securely support a variety of packaging systems that may be stacked on top of the top cap 10. In this embodiment, the top surface 12 includes a plurality of raised portions 14, 16, 18, which cooperate with (and in effect create) indented portions 20, 22. Certain of the raised portions 14, 16 extend upward from the raised portion 18. Indented portion 20 extends along the periphery of the top surface 12 and includes a variety of shaped regions or pockets 24, 26, 28 that extend into the raised portion 18.

[0062] A second embodiment of a top cap 30 in accordance with the present invention is shown in Figure 2. Although having a different pattern, the top cap 30 (similar to the embodiment of Figure 1), also includes a top surface 32 having a plurality of raised portions 34, 36, 38, 40, and indented portions 42, 44, 46, 48, 50.

[0063] In both embodiments, the topography of the top surfaces 12, 32 of the top caps 10, 30 is designed to securely mate with the footprints (i.e., of the bottom surface or structure) of one or more pallet designs, one or more bulk bin designs, and one or more metal rack designs. Accordingly, the top caps 10, 30 allow any of these designs to be securely stacked on the top surfaces 12, 32.

[0064] Both top caps 10, 30 shown in Figures 1 and 2, are configured to allow the same series of pallets, bulk bins and metal racks to be stacked on the top caps 10, 30. Additionally, each top cap 10, 30 is designed to stack with other top caps having the same configuration, and in some instances, with top caps of different design (such as an earlier model).

[0065] The top caps 10, 30 are preferably designed to allow the following pallets to securely stack onto the top surfaces 12, 32: ORBIS® 45x48-A CISF; ORBIS® 45x48-B CISF; ORBIS® 45x48-C CISF; ORBIS® 45x48-2 CISS; ORBIS® Powerlite™; ORBIS® AutoPal™; Schaefer Krypto-Lite®.

[0066] Figure 3A shows a bottom plan view of the footprint of the bottom surface or structure 41 of the ORBIS® 45x48-A CISF and 45x48-B CISF pallets 47 (both pallets have the identical bottom surface or structure). Figure 3B provides a prospective view of the bottom surface or structure 41. The bottom surface or structure 41 includes a plurality of legs 43 which extend from the bottom surface 45 of the pallet 47. The legs 43 are grouped in pairs which are arranged in three rows or columns. The pallet 47 is a molded plastic having a plurality of ribs (not shown) which also extend from the bottom surface 45.

[0067] Figure 4A shows a bottom plan view of the footprint of the bottom surface or structure 49 of the ORBIS® 45x48-C CISF pallet 51. Figure 4B provides a perspective view of the bottom surface or structure 49. The bottom surface or structure includes legs 52, 54, 56 extending from a bottom surface 58. The legs 52 positioned proximate the corners of the pallet 51 are larger (i.e., have a larger cross-section) than the legs 54 positioned between the corners, which in turn, are larger than the leg 56 positioned in the center of the pallet 51.

[0068] Figure 5A shows a bottom plan view of the footprint of the bottom surface or structure 60 of the ORBIS® 45x48-2 CISS pallet 62. Figure 5B provides a perspective view of the bottom surface or structure 60. The pallet includes legs 64 having a more complex shape than the legs of the pallets of Figures 3A, 3B, 4A and 4B.

[0069] Figure 6A shows a bottom plan view of the footprint of the bottom surface or structure 66 of the ORBIS® 45x48 Powerlite™ pallet 68. This pallet 68 includes legs 70.

[0070] Figure 7A shows a bottom plan view of the footprint of the bottom surface or structure 72 of the ORBIS® 45x48 AutoPal™ pallet 74, and Figure 7B shows a

perspective view of the pallet 72. This pallet 74 includes legs 76. The ORBIS® 45x48 AutoPal™ pallet 74 has the same footprint as the Schaefer 45x48 AutoPal™ pallet.

[0071] Figure 8A shows a bottom plan view of the footprint of the bottom surface or structure 78 of the Schaefer 45x48 Krypto-Lite® pallet 80, and Figure 8B shows a perspective view of the pallet 80. This pallet includes legs 82 having a rectangular cross-section and legs 84 having a notch or cut-out at the bottom of the leg.

[0072] The top caps 10, 30 are also preferably designed to allow the following bulk bins to securely stack onto the top surfaces 12, 32: ORBIS® 45x48 Heavy Duty and Medium Duty bulk bins, and Buckhorn 45x48 bulk bins.

[0073] Figure 9A provides a bottom plan view of the bottom surface or structure 86 of the ORBIS® KD45x48 Medium Duty bulk bin 88. Figure 9B is a perspective view of the bulk bin 88. This bulk bin 88 includes stringers 90 extending along an outer periphery of the bottom surface of the bin 88.

[0074] Figure 10A provides a bottom plan view of the bottom surface or structure 94 of the ORBIS® HD45x48 Heavy-Duty bulk bin 96. Figure 10B is a perspective view of the bulk bin 96. This bulk bin 96 includes feet 98.

[0075] Figure 11A shows a bottom plan view of the bottom surface or structure 100 of the ORBIS® HDR45x48 Heavy Duty bulk bin 102. Figure 11B is a perspective view of the bulk bin 102. Both Figures show a simplified representation of the bottom surface or structure 100. The actual bulk bin 102 has a more complicated structure similar to that shown in Figures 10A and 10B.

[0076] Figure 12A shows a bottom plan view of the bottom surface or structure 104 of the Buckhorn 45x48 bulk bin 106. Figure 12B is a perspective view of the bulk bin 106. Both Figures show a simplified representation of the bottom surface or structure 104. The actual bulk bin 106 has a more complicated structure.

[0077] Figure 13B provides a bottom plan view of the bottom surface or structure 108 of the 45x48 Steel Rack 110. Figure 13A provides a perspective view of the steel rack 110.

[0078] Figures 14A and 14B show a perspective view and a plan view, respectively, of another model top cap 112 (the ORBIS® MP2). The present top caps 10, 30 are configured to nest with this top cap 112 to provide greater shipping efficiencies when transporting the top caps 10, 30 and/or 112.

[0079] Figures 15(A and B) – 26(A and B) provide a top perspective view of the top caps 10, 30, of the present invention, respectively, in a side-by-side arrangement. In each of these views, the footprint of the bottom surface or structures of the various pallets, bulk bins and metal rack is shown in phantom.

[0080] Specifically, Figures 15A and 15B show the footprint 116 (i.e., all of the shapes, collectively, shown in phantom) of the bottom surface or structure 41 of the ORBIS® 45x48-A CISF and 45x48-B CISF pallets 47 of Figures 3A and 3B. The legs 43 of the bottom surface or structure 41 are captured and supported by the raised and indented portions of the top caps 10, 30 in a manner that would prevent the pallets from slipping when stacked on the top caps 10, 30.

[0081] Figures 16A and 16B provide the footprint 118 of the bottom surface or structure 48 of the ORBIS® 45x48-C CISF pallet 51 shown in Figures 4A and 4B. Again, the raised and indented portions of the top caps 10, 30 are designed to capture and support the bottom surface or structure 49 to prevent the pallet 51 from slipping when stacked on the top caps 10, 30.

[0082] In like manner, Figures 17A and 17B provide the footprint 120 for the bottom surface or structure 60 of the ORBIS® 45x48-2 CISS pallet 62 shown in Figures 5A and 5B. Figures 18A and 18B provide the footprint 122 of the bottom surface or structure 66 of the ORBIS® 45x48 Powerlite™ pallet 68 shown in Figures 6A and 6B. Figures 19A and 19B provide the footprint 124 of the bottom surface or structure 72 of the ORBIS® 45x48 AutoPal™ pallet 74 shown in Figures 7A and 7B. Figures 20A and 20B provide the footprint 126 of the bottom surface or structure 78 of the Schaefer 45x48 Krypto-Lite® pallet 80 shown in Figures 8A and 8B.

[0083] Similar to the pallet footprints, Figures 21A and 21B show the footprint 128 of the bottom surface or structure 86 of the ORBIS® HD45x48 Medium Duty bulk bin 88 shown in Figures 9A and 9B. Figures 22A and 22B show the footprint 130 of the bottom surface or structure 94 of the ORBIS® HD45x48 Heavy-Duty bulk bin 96 shown in Figures 10A and 10B. Figures 23A and 23B show the footprint 132 of the bottom surface or structure 104 of the Buckhorn 45x48 bulk bin 106 shown in Figures 12A and 12B. Figures 24A and 24B show the footprint 134 of the bottom surface or structure 150 of the ORBIS® KDR45x48 Medium Duty bulk bin 152 shown in Figures 29A and 29B. Figures

25A and 25B show the footprint 136 of the bottom surface or structure 100 of the ORBIS® HDR45x48 Heavy Duty bulk bin 102 shown in Figures 11A and 11B.

[0084] Similar to the pallet and bulk bin footprints, Figures 26A and 26b show the footprint 138 of the bottom surface or structure 108 of the 45x48 Steel Rack 110 shown in Figures 13A and 13b. In particular, the corner projections 40 of the top cap 30 (Figure 26B) are configured to coincide with the ends of the segments that make up the footprint 138, to properly align the Rack 110 on top of the top cap 30, and prevent movement of the Rack 110 during transportation.

[0085] Referring to Figure 27, a bottom view of the top cap 30 is provided. The bottom 140 of the top cap 30 includes a support plurality of ribs 142 extending downward from the bottom 140.

[0086] Figure 28 provides another design for a top cap 144 made in accordance with the present invention. The top cap 144 is an intermediate design of the top cap 30.

[0087] While the specific embodiments have been illustrated and described, numerous modifications come to mind without significantly departing from the spirit of the invention, and the scope of protection is only limited by the scope of the accompanying Claims.

CLAIMS

What is claimed is:

1. **A top cap comprising:
a generally rectangular sheet having a lower surface and an upper surface, the upper surface contoured to securely mate with a bottom surface of a first pallet, a bottom surface of a first bulk bin, and a bottom surface of a first metal rack.**
2. **The top cap of claim 1 wherein the upper surface is contoured to securely mate with a bottom surface of a second pallet having a configuration different than the bottom surface of the first pallet, a bottom surface of a second bulk bin having a configuration different than the bottom surface of the first bulk bin, and a bottom surface of a second metal rack having a configuration different than the bottom surface of the first metal rack.**
3. **The top cap of claim 1 wherein the generally rectangular sheet is plastic.**
4. **A top cap comprising:
a first surface configured to securely mate with a footprint of a first pallet design, a footprint of a first bulk bin design, and a footprint of a first metal rack design, the first surface including raised corner portions for mating with the first metal rack design; and,
a second surface opposing the first surface for contacting one or more items.**
5. **The top cap of claim 4 wherein the first pallet design is for a nestable pallet.**
6. **The top cap of claim 4 wherein the first surface is further configured to mate with a footprint of a second pallet design different than the footprint of the first pallet design.**
7. **The top cap of claim 4 wherein the first surface is further configured to mate with a footprint of a second bulk bin design different than the footprint of the first bulk bin design.**

8. The top cap of claim 4 wherein the first surface is further configured to mate with a footprint of a second metal rack design different than the footprint of the first metal rack design.
9. The top cap of claim 4 comprising a first set of raised portions on the first surface positioned to mate with a bottom surface defining the footprint of the first pallet.
10. The top cap of claim 4 comprising a first set of raised portions on the first surface positioned to mate with a bottom surface defining the footprint of the first bulk bin.
11. The top cap of claim 4 comprising a first set of raised portions on the first surface positioned to mate with a bottom surface defining the footprint of the first metal rack.
12. The top cap of claim 4 wherein the top cap is formed from a molded plastic.
13. The top cap of claim 4 further comprising a plurality of ribs projecting away from the second surface.
14. The top cap of claim 4 wherein the top cap is configured to nest with one of another same model top cap and another different model top cap.
15. A plastic top cap for use in transporting goods and being configured for facilitating stacking of other transportation components, the top cap comprising:
 - an upper surface having a first plurality of raised portions configured to securely capture a bottom surface of a first pallet having a first pallet footprint design, a second plurality of raised portions configured to securely capture a bottom surface of a first bulk bin having a first bulk bin footprint design; and a third plurality of raised portions configured to securely capture a bottom surface of a first metal rack having a first metal rack footprint design.

16. The plastic top cap of claim 15 further comprising a fourth plurality of raised portions configured to capture a bottom surface of a second pallet having a second pallet footprint design different than the first pallet footprint design.
17. The plastic top cap of claim 15 further comprising a fourth plurality of raised portions configured to capture a bottom surface of a second bulk bin having a second bulk bin footprint design different than the first bulk bin footprint design.
18. The plastic top cap of claim 15 further comprising a fourth plurality of raised portions configured to capture a bottom surface of a second metal rack having a second metal rack footprint design different than the first metal rack footprint design.
19. The plastic top cap of claim 15 further comprising a second side for contacting items being transported, the second side including a plurality of downwardly extending ribs.
20. The plastic top cap of claim 15 configured to securely stack with another top cap.

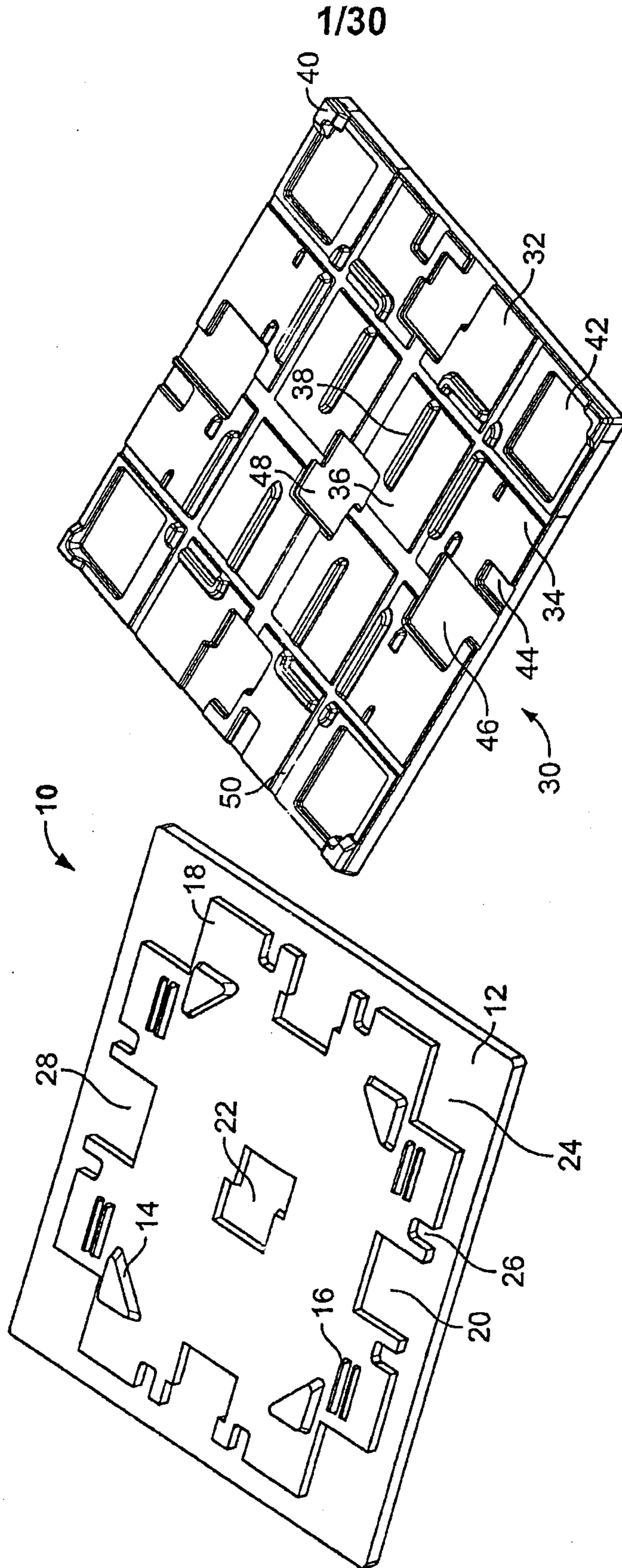

FIG. 1

FIG. 2

2/30

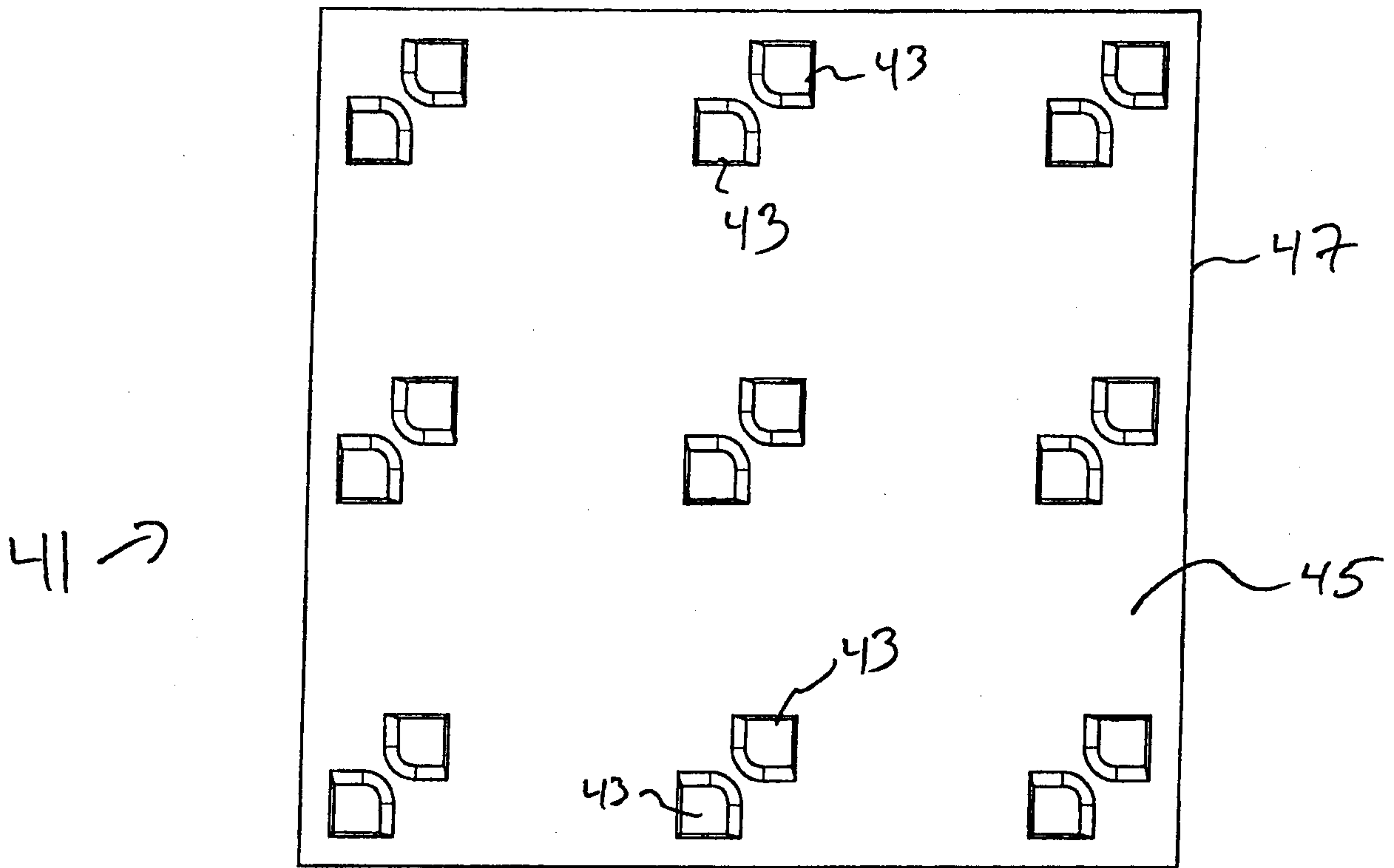

FIG. 3A

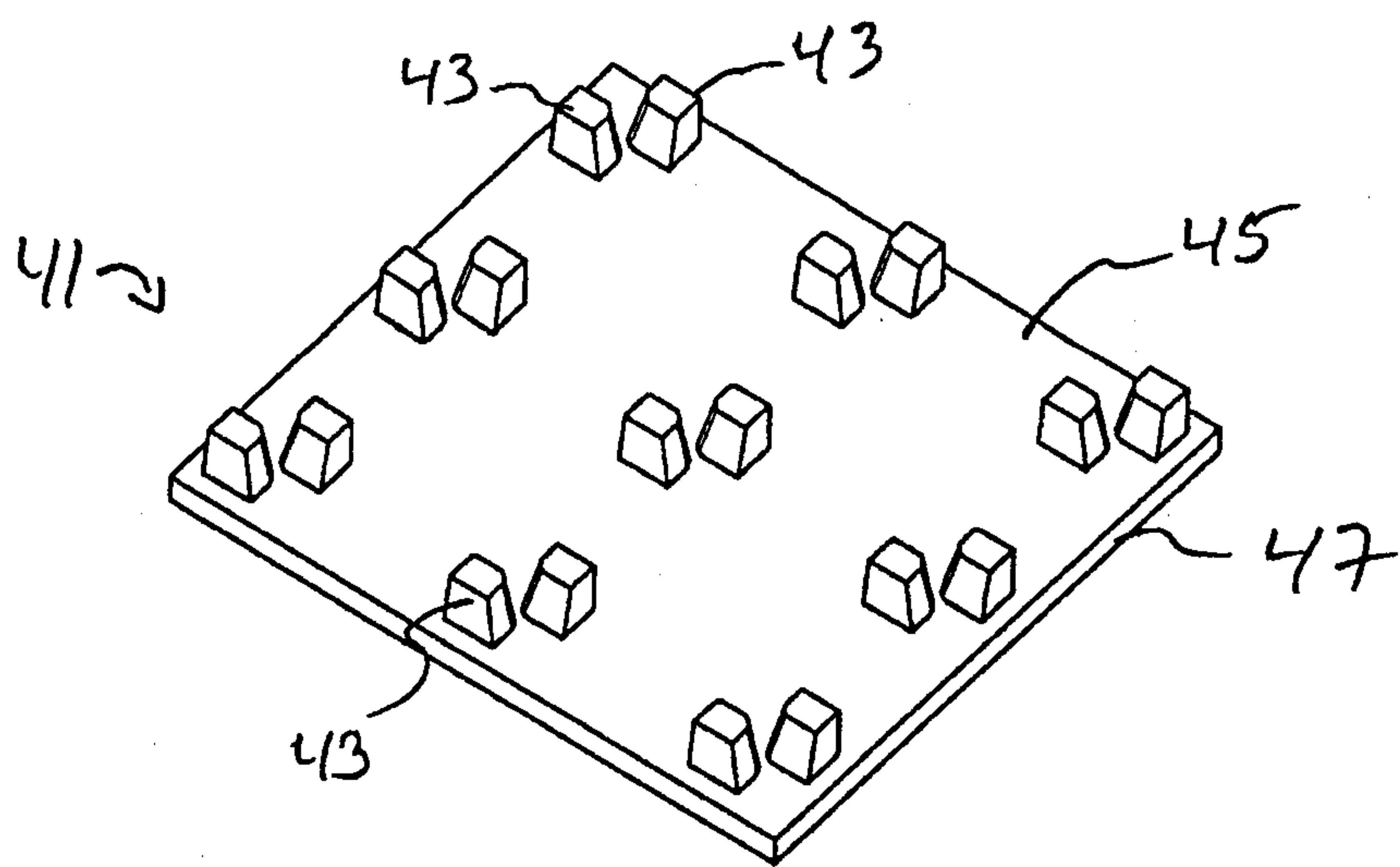

FIG. 3B

3/30

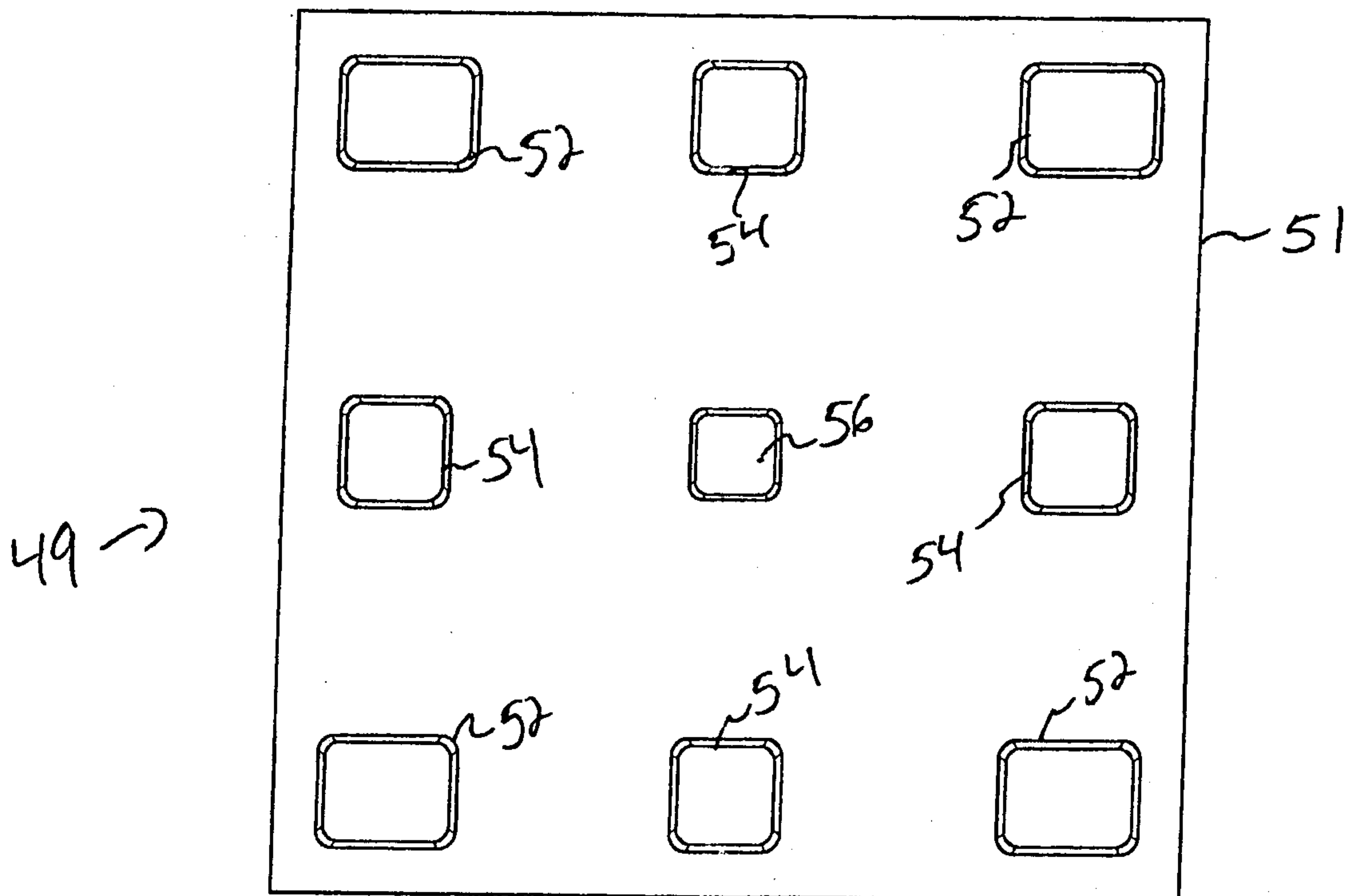

FIG. 4A

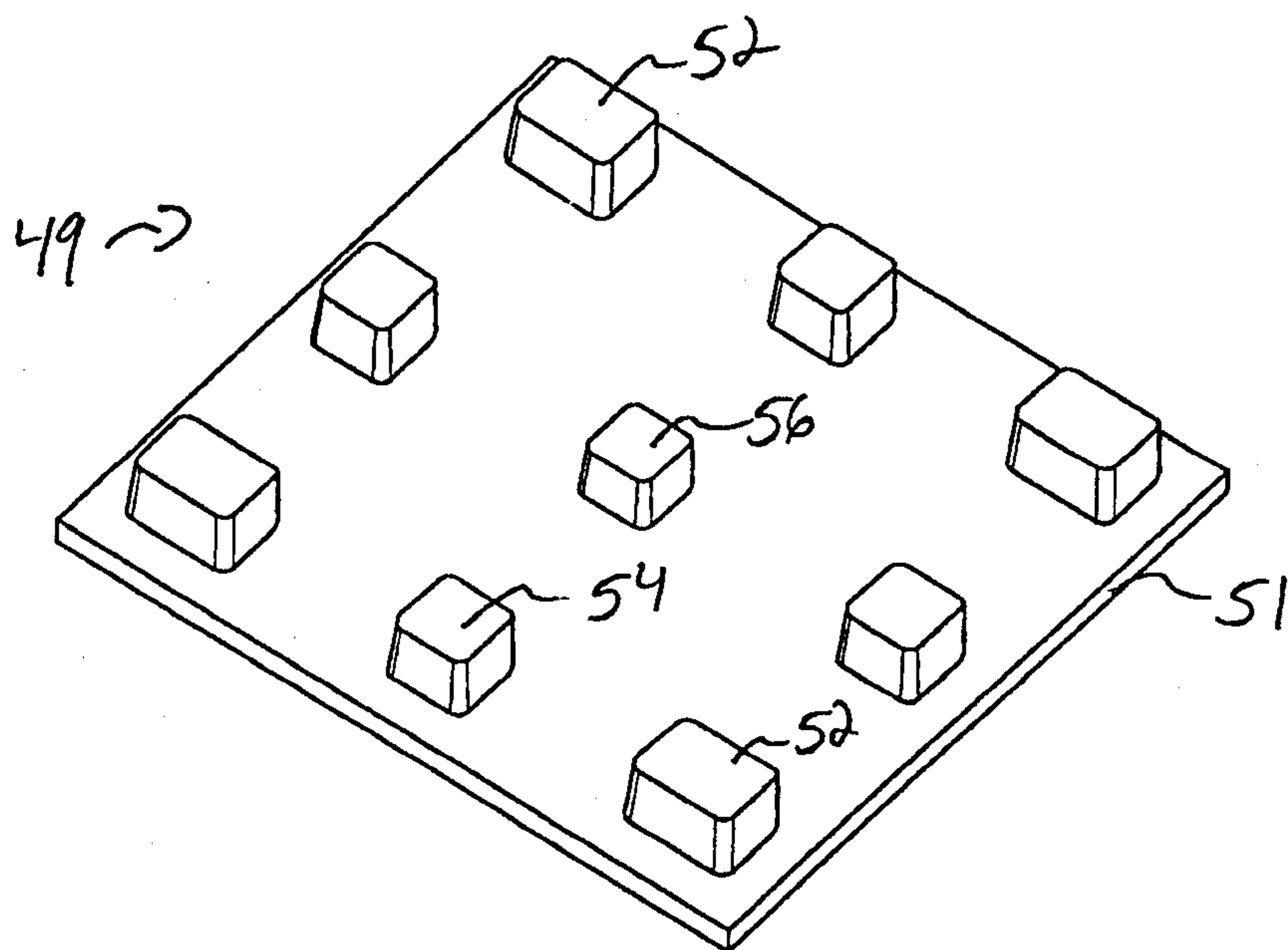

FIG. 4B

4/30

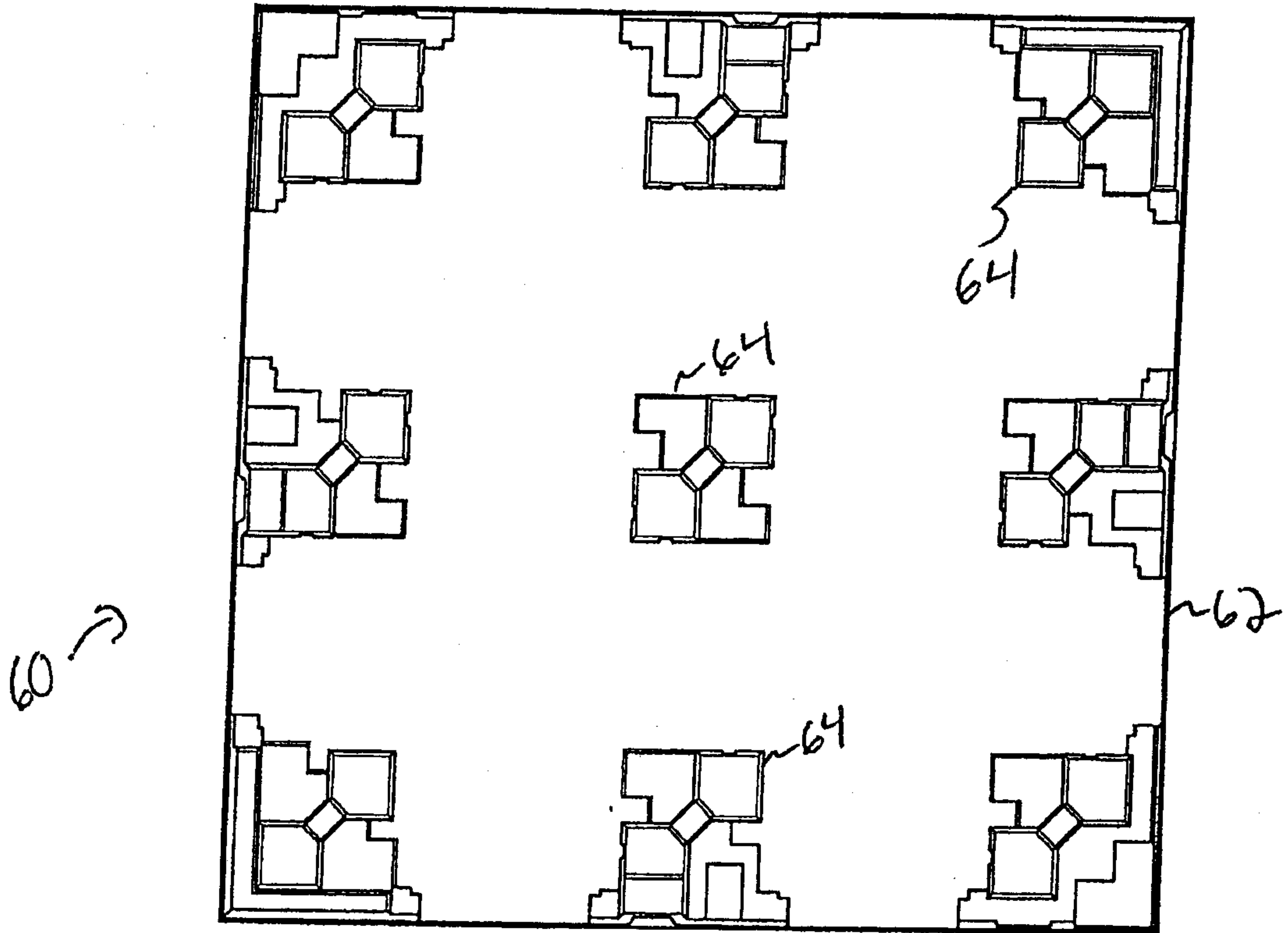

FIG. 5A

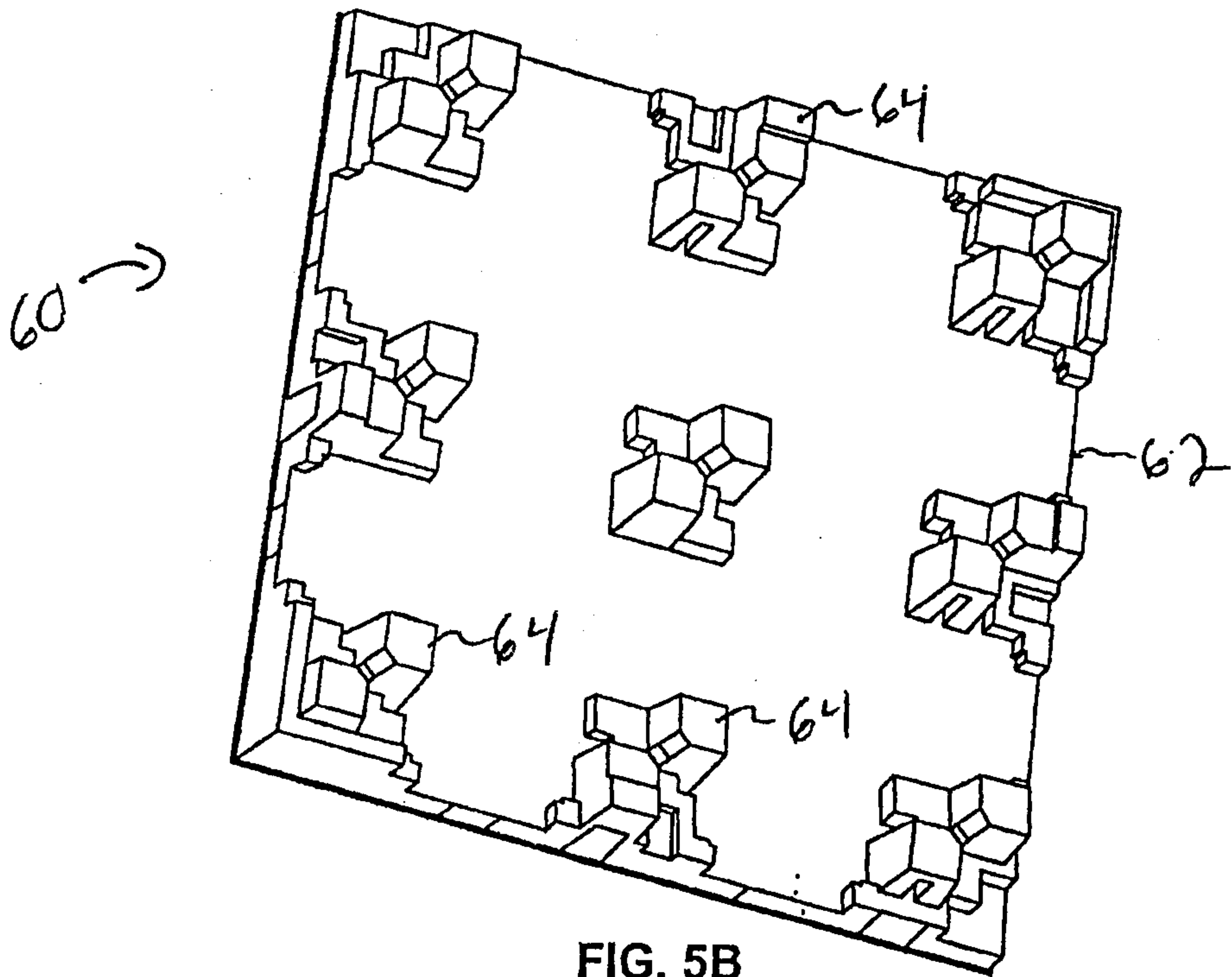

FIG. 5B

5/30

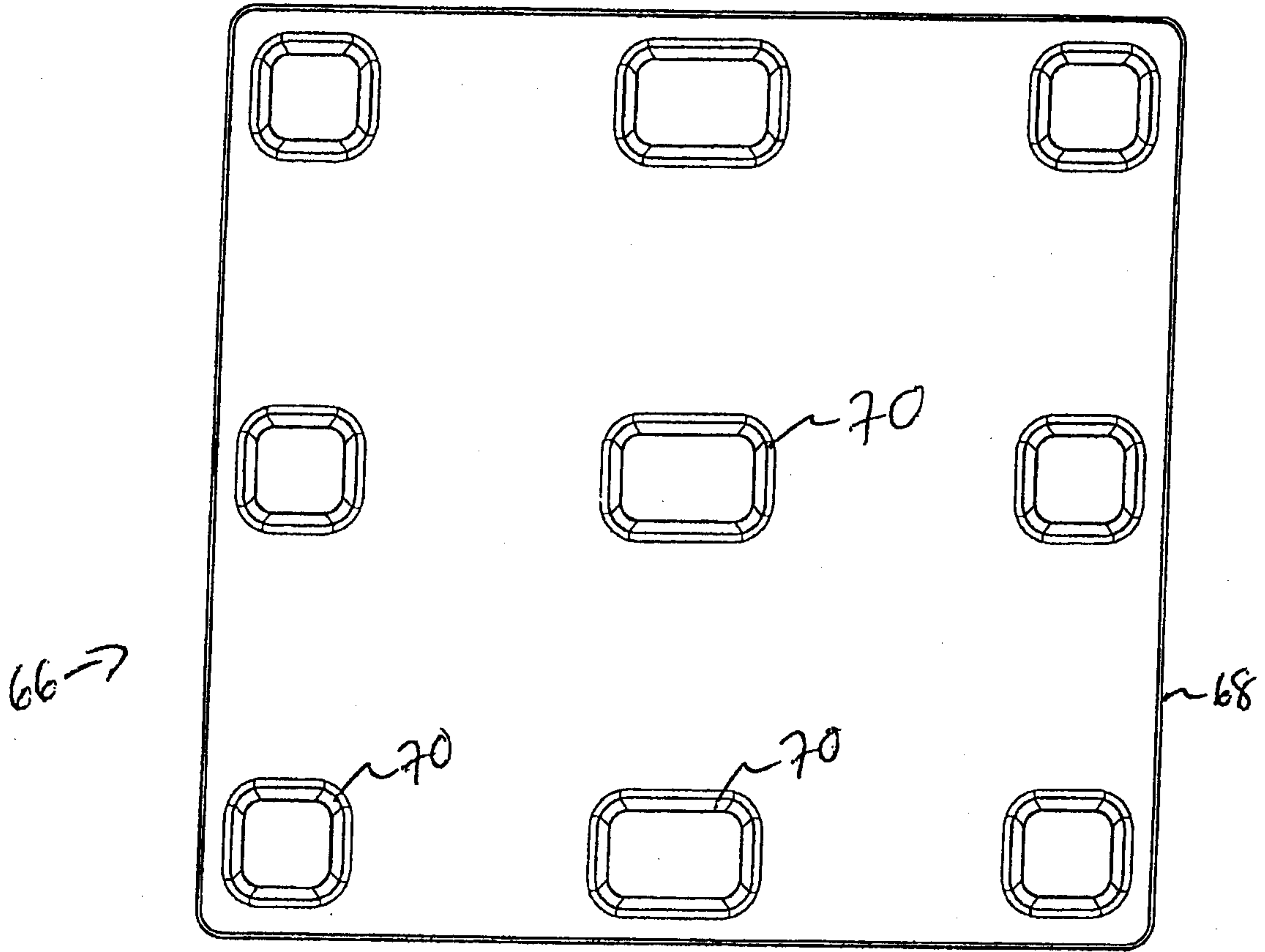

FIG. 6A

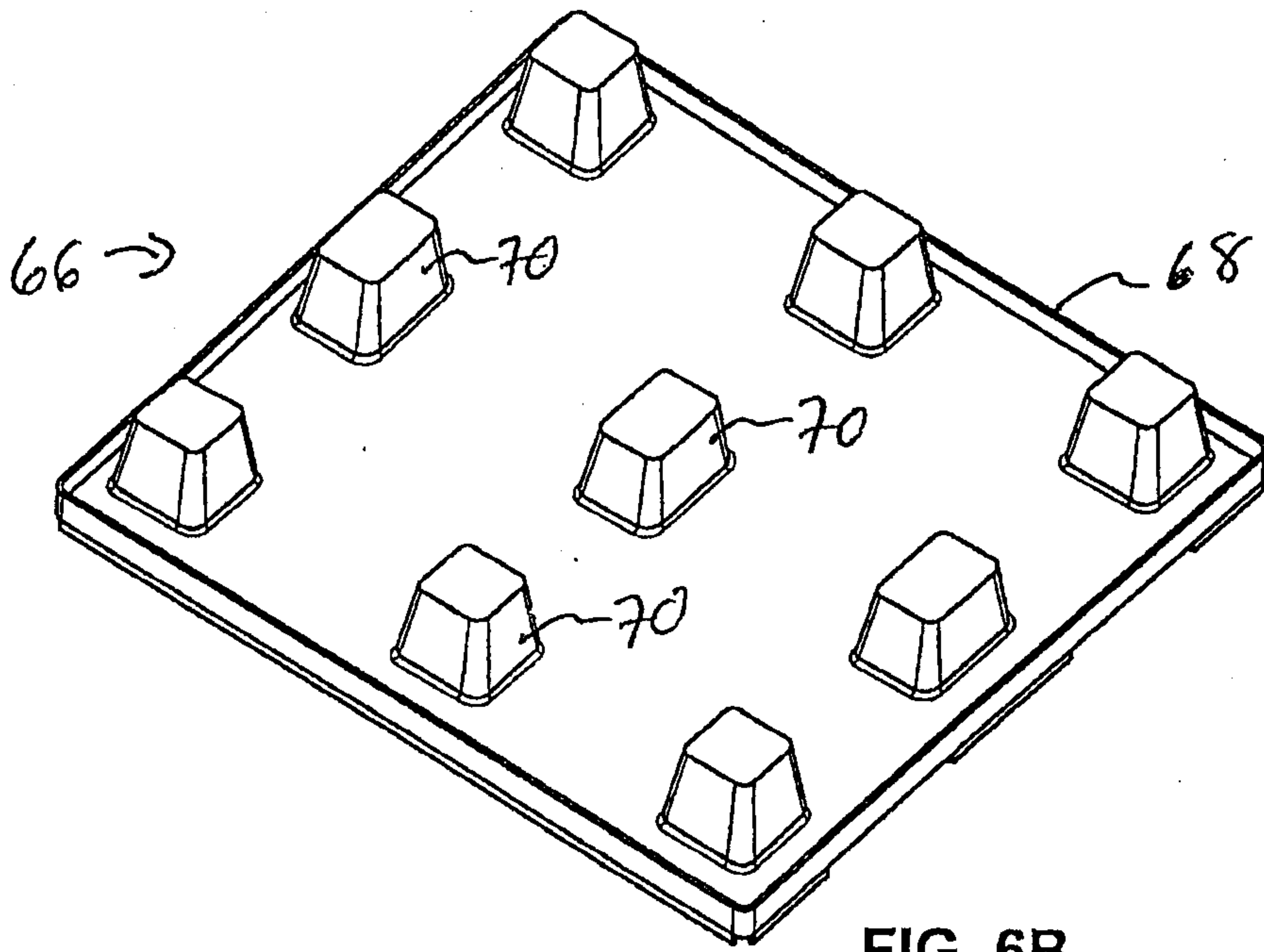

FIG. 6B

6/30

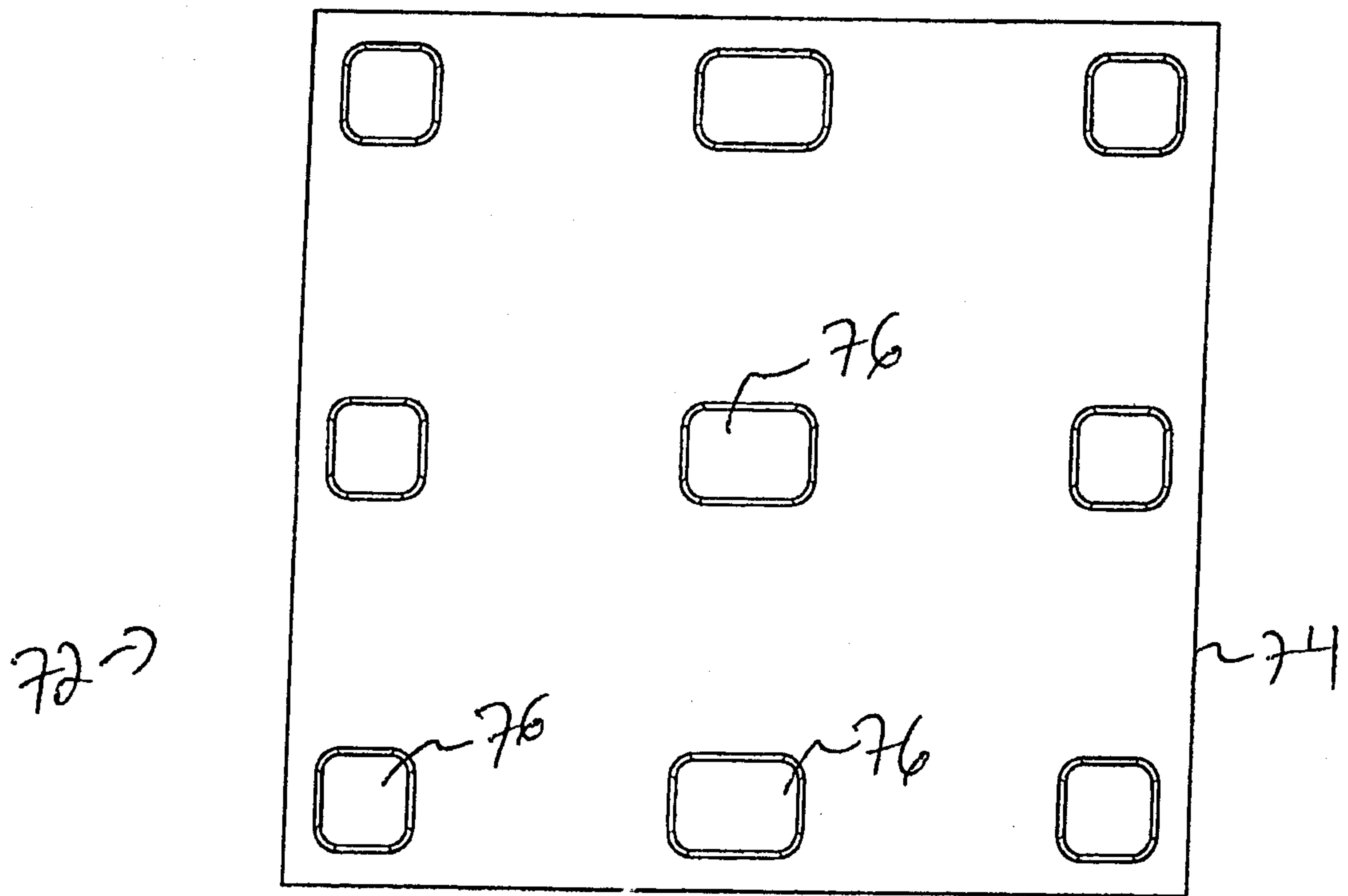

FIG. 7A

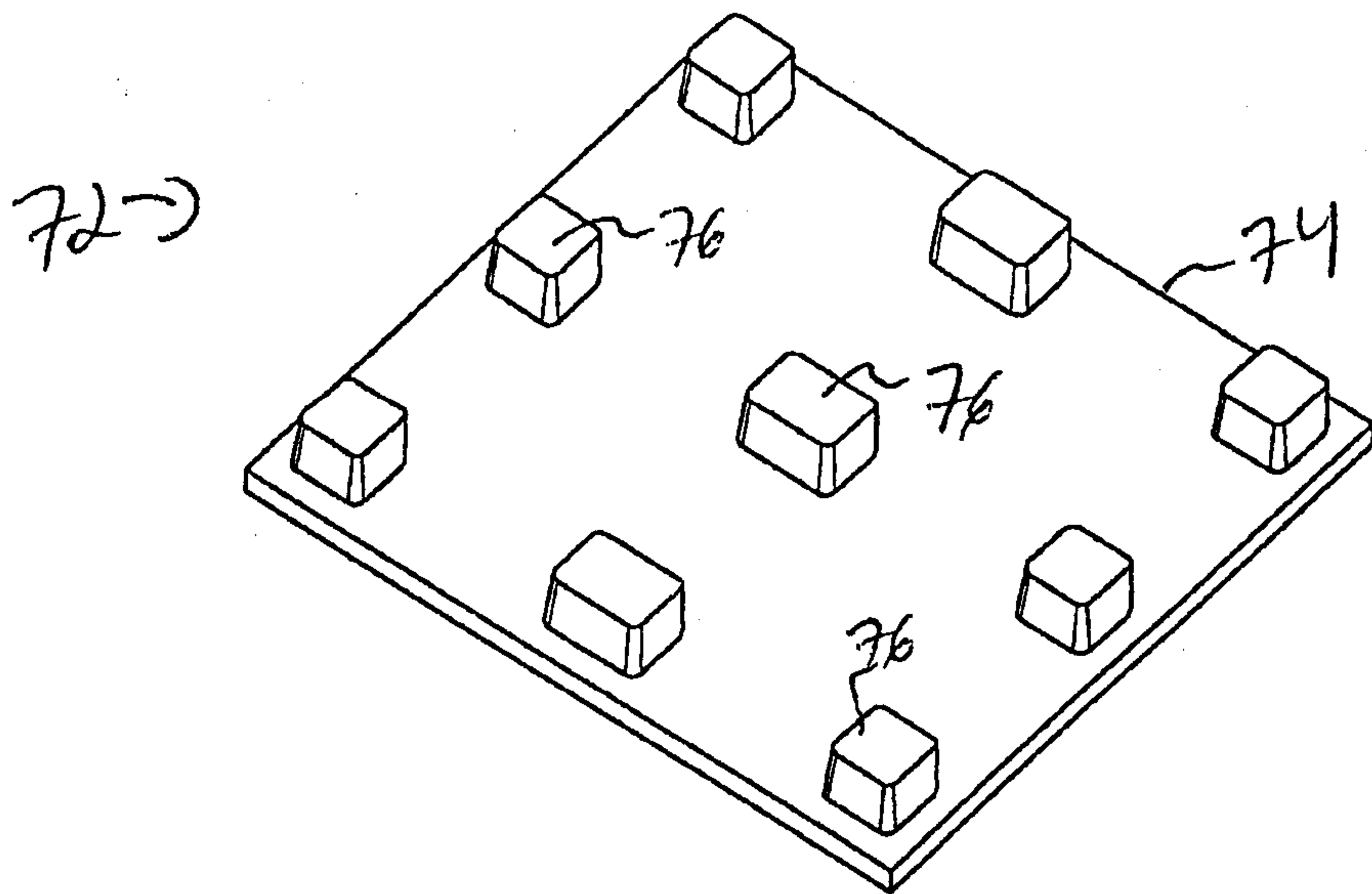

FIG. 7B

7/30

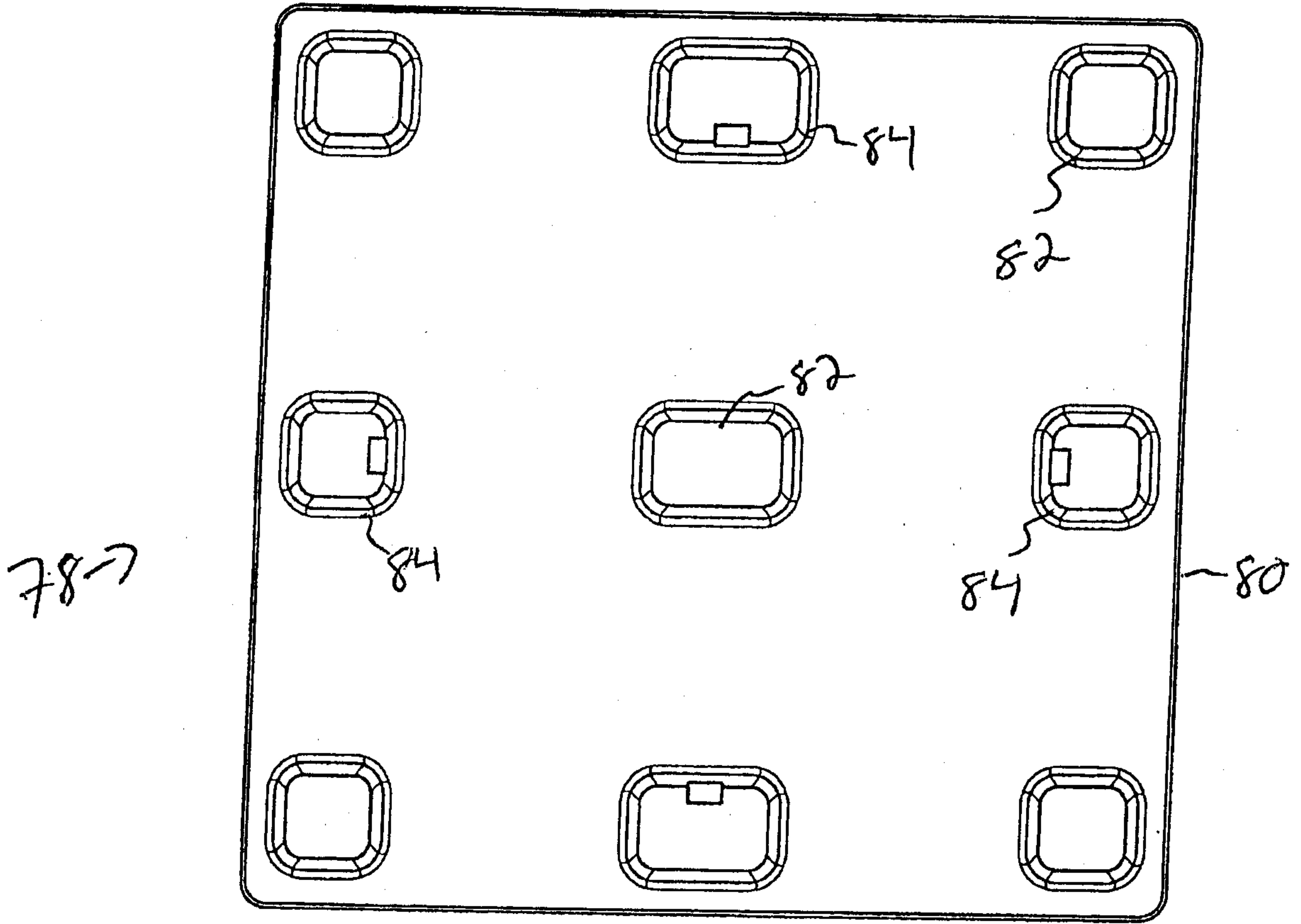

FIG. 8A

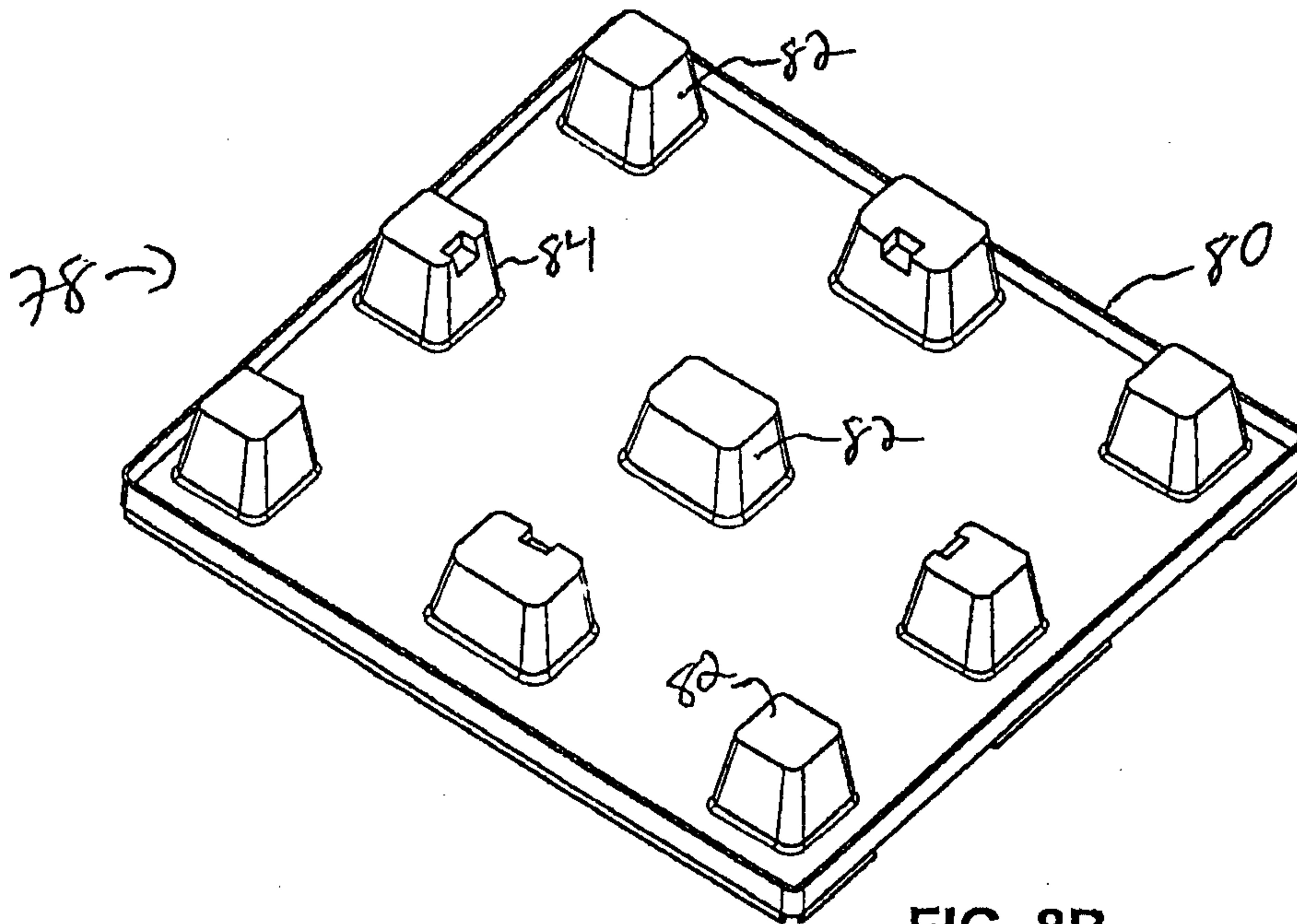

FIG. 8B

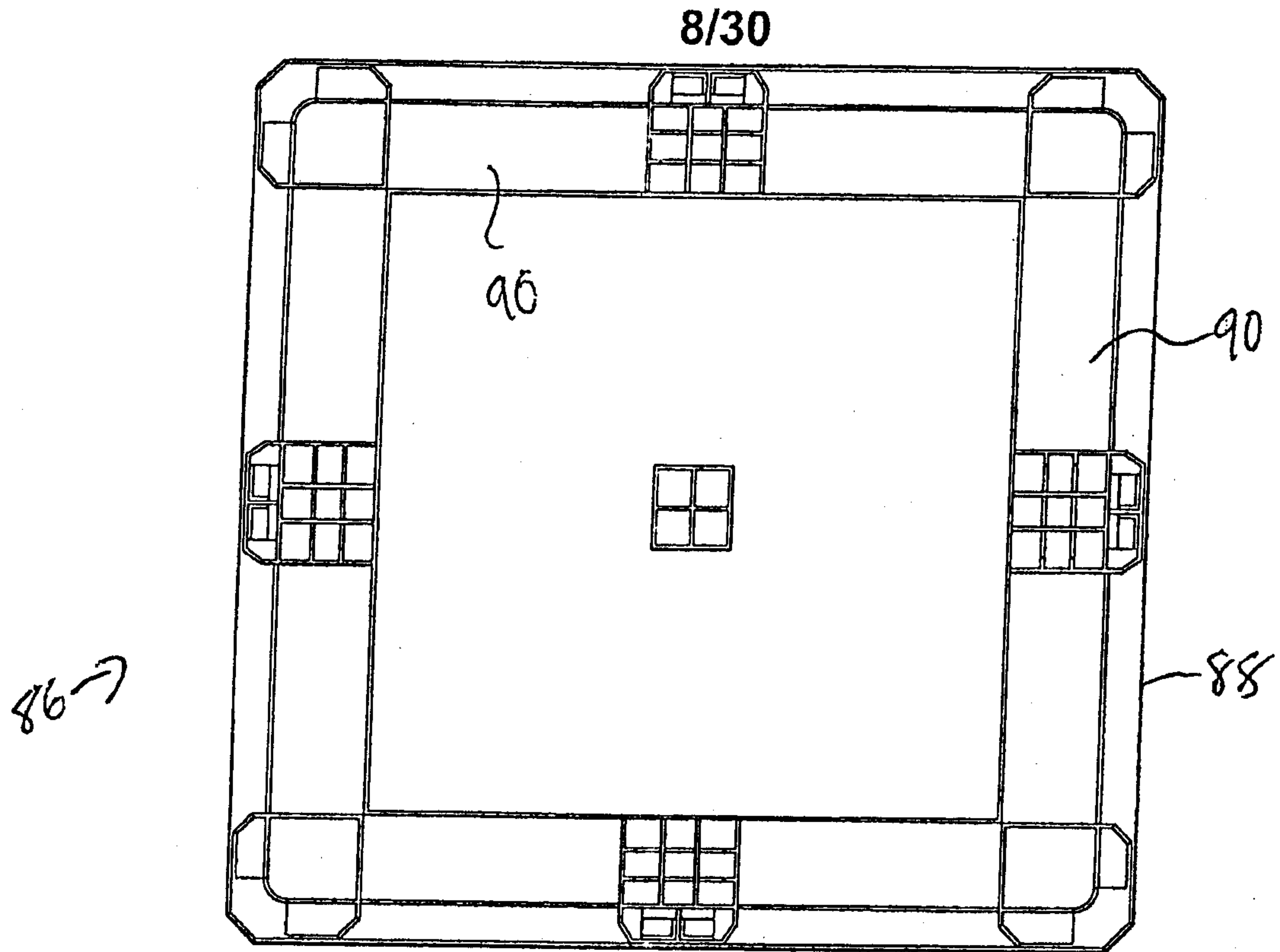

FIG. 9A

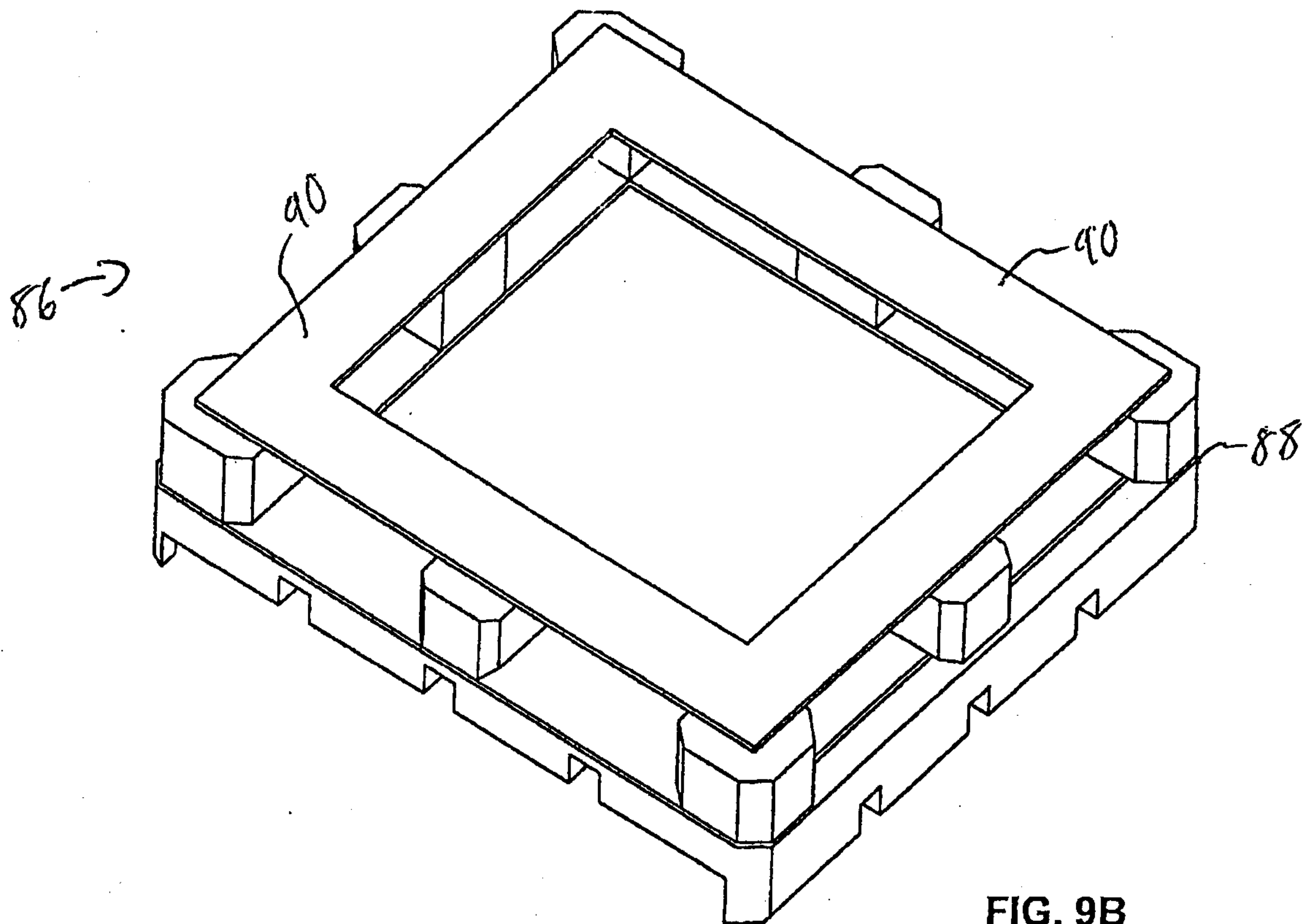

FIG. 9B

9/30

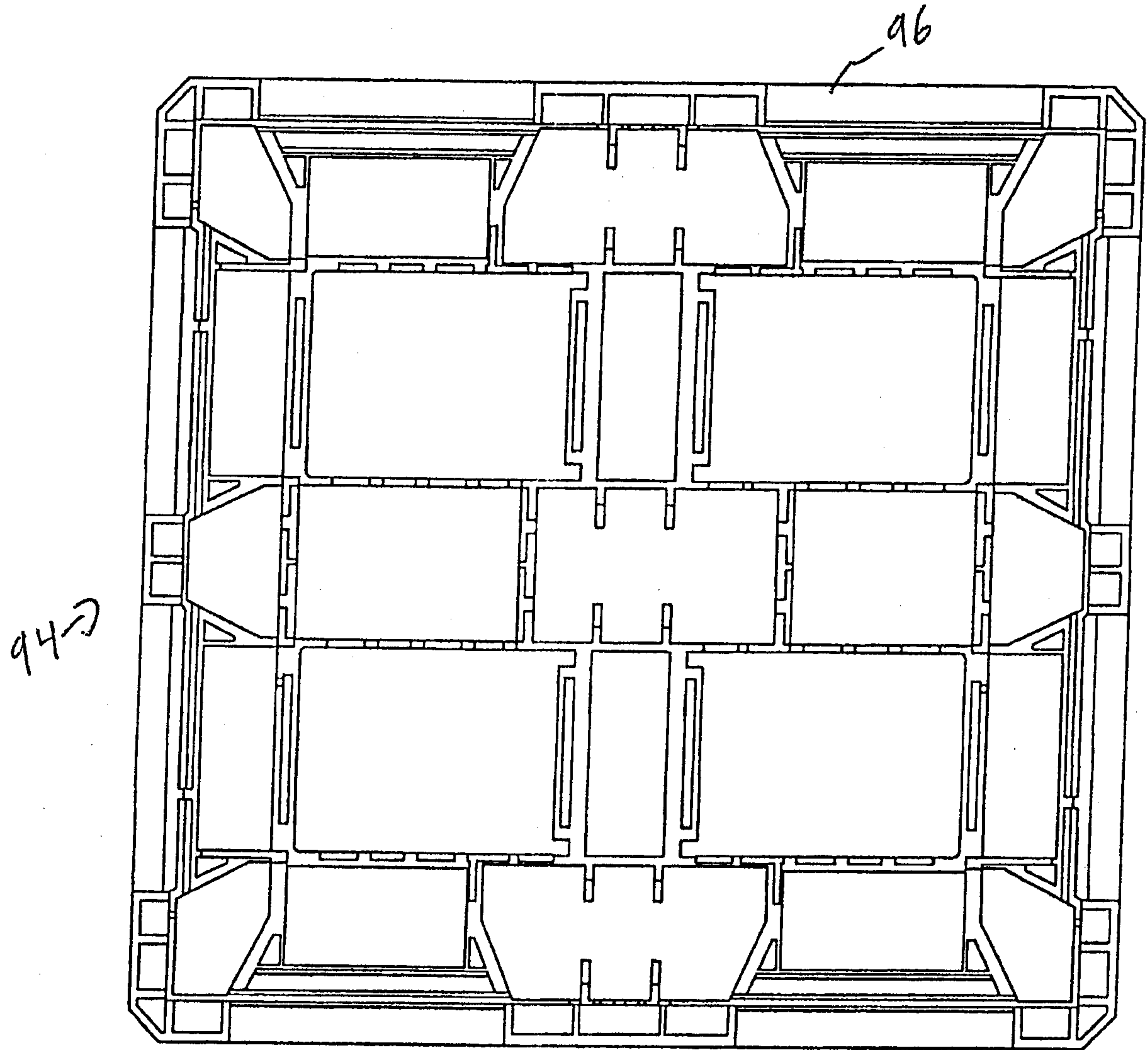

FIG. 10A

10/30

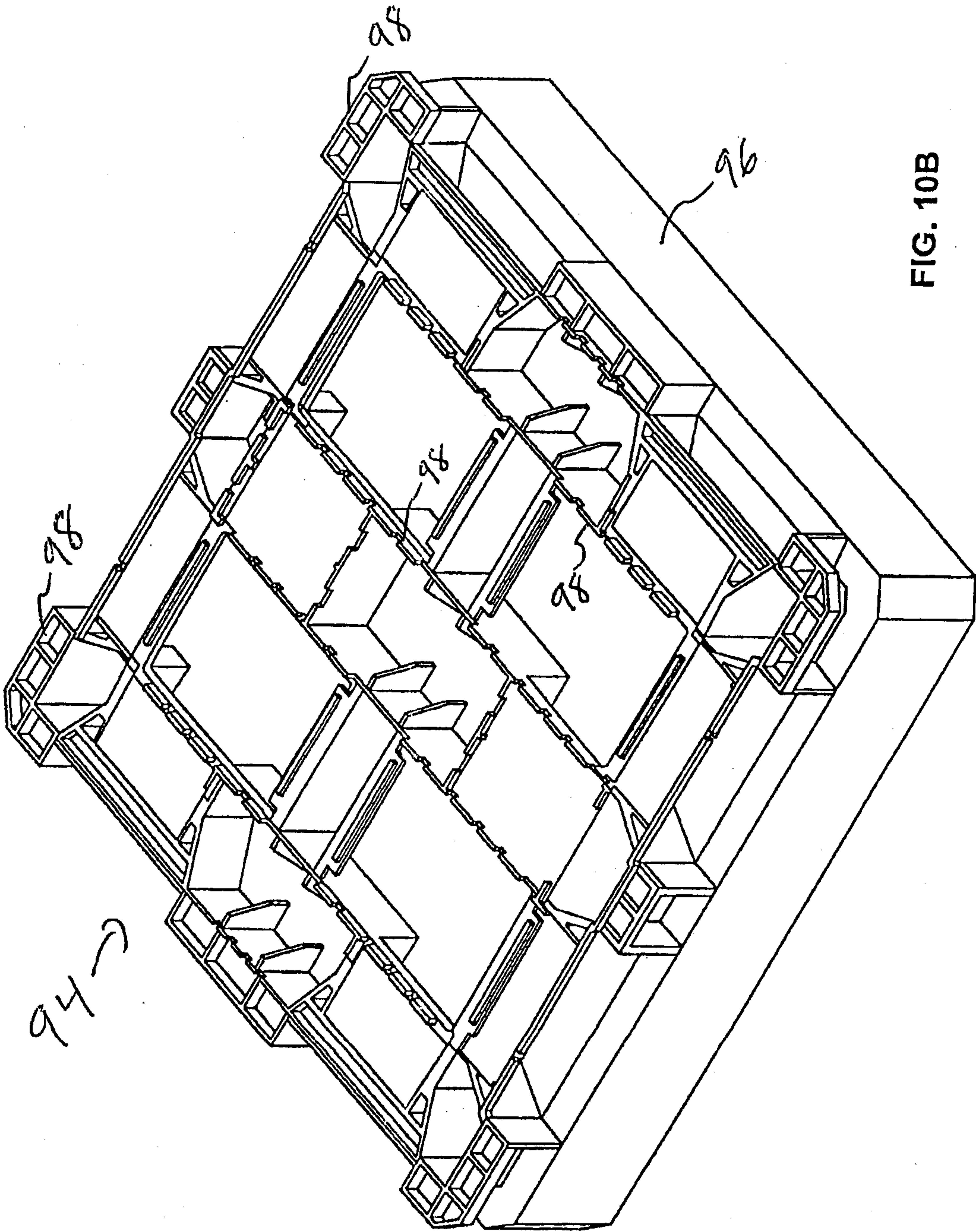

FIG. 10B

11/30

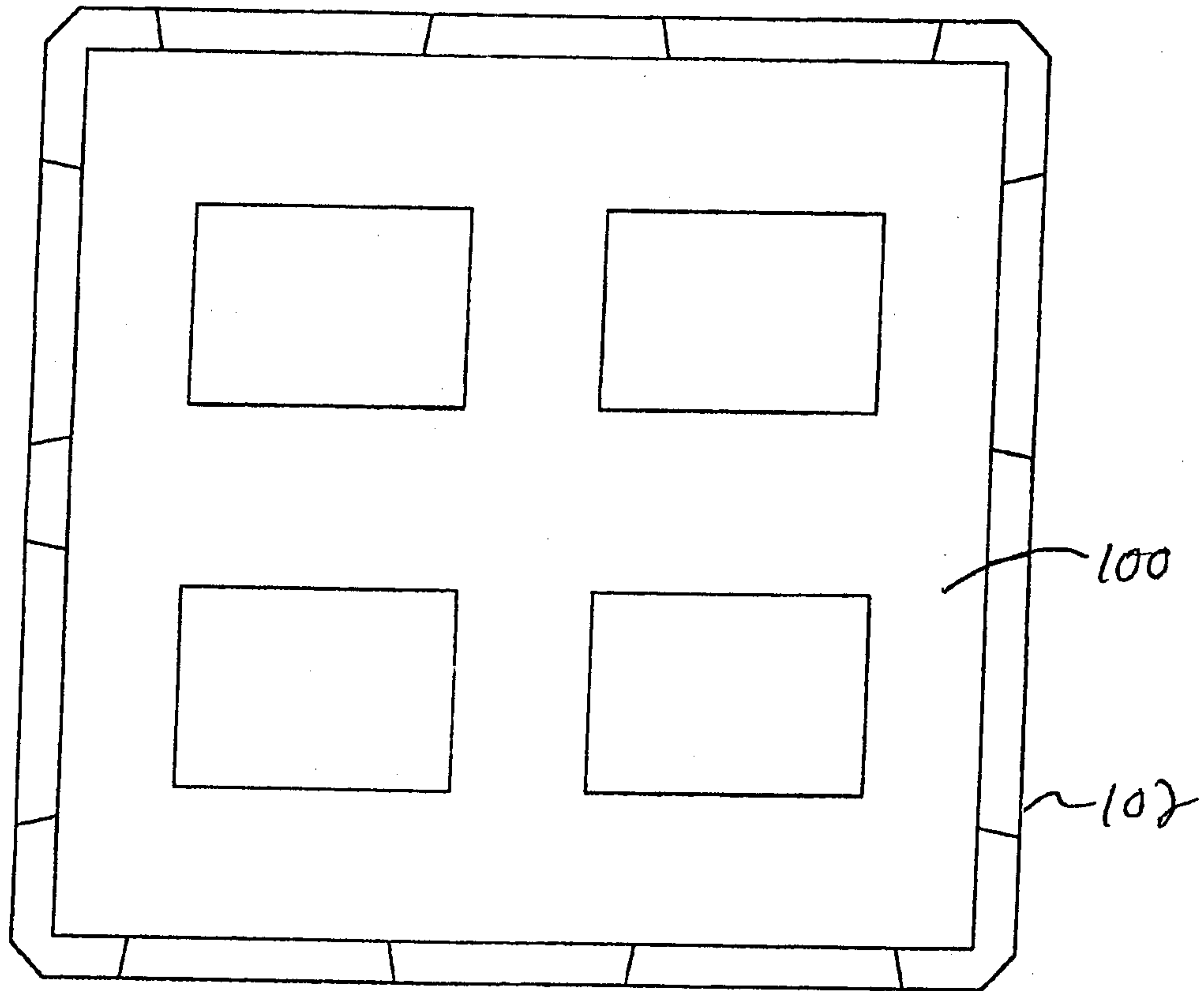

FIG. 11A

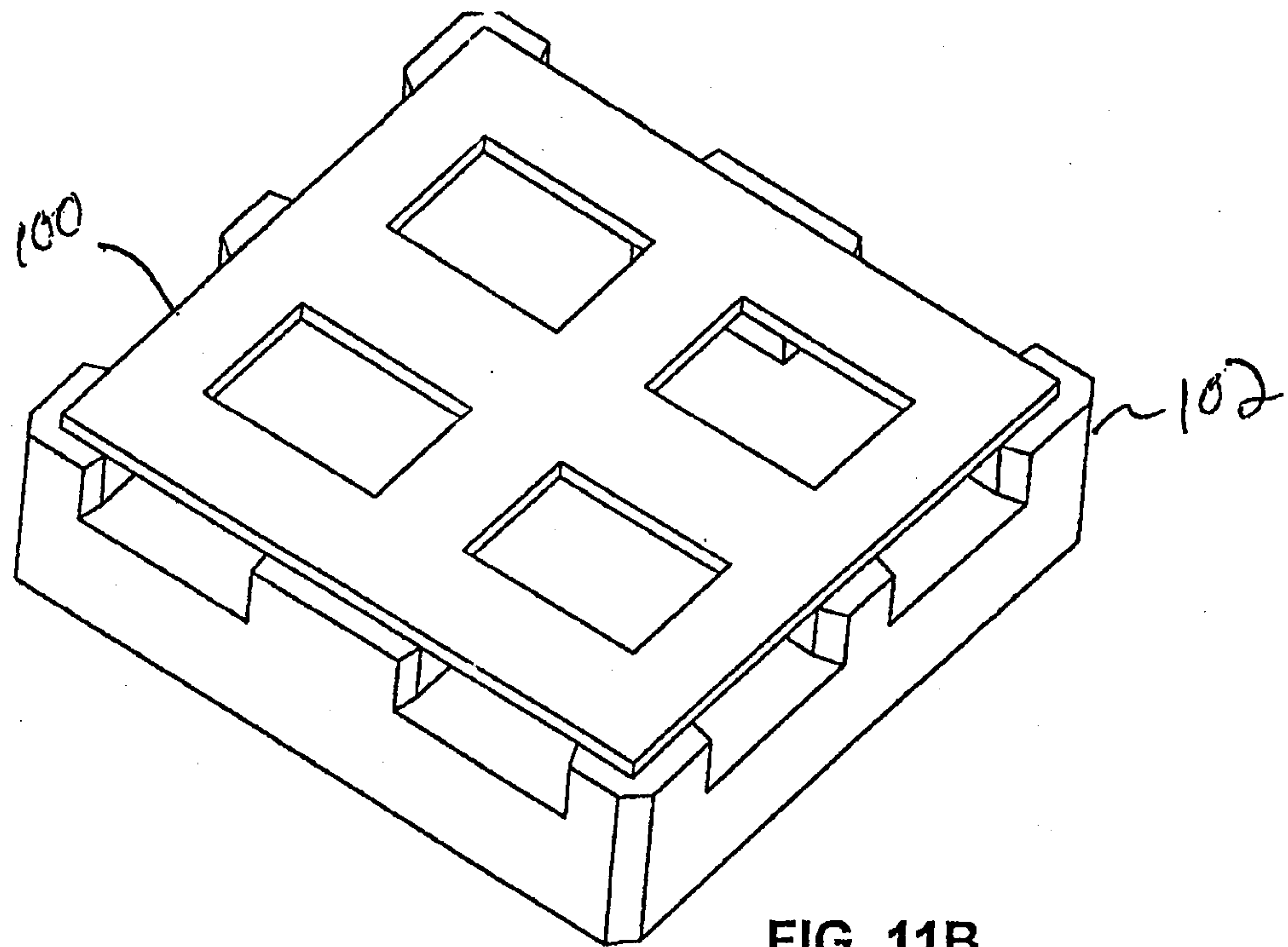

FIG. 11B

12/30

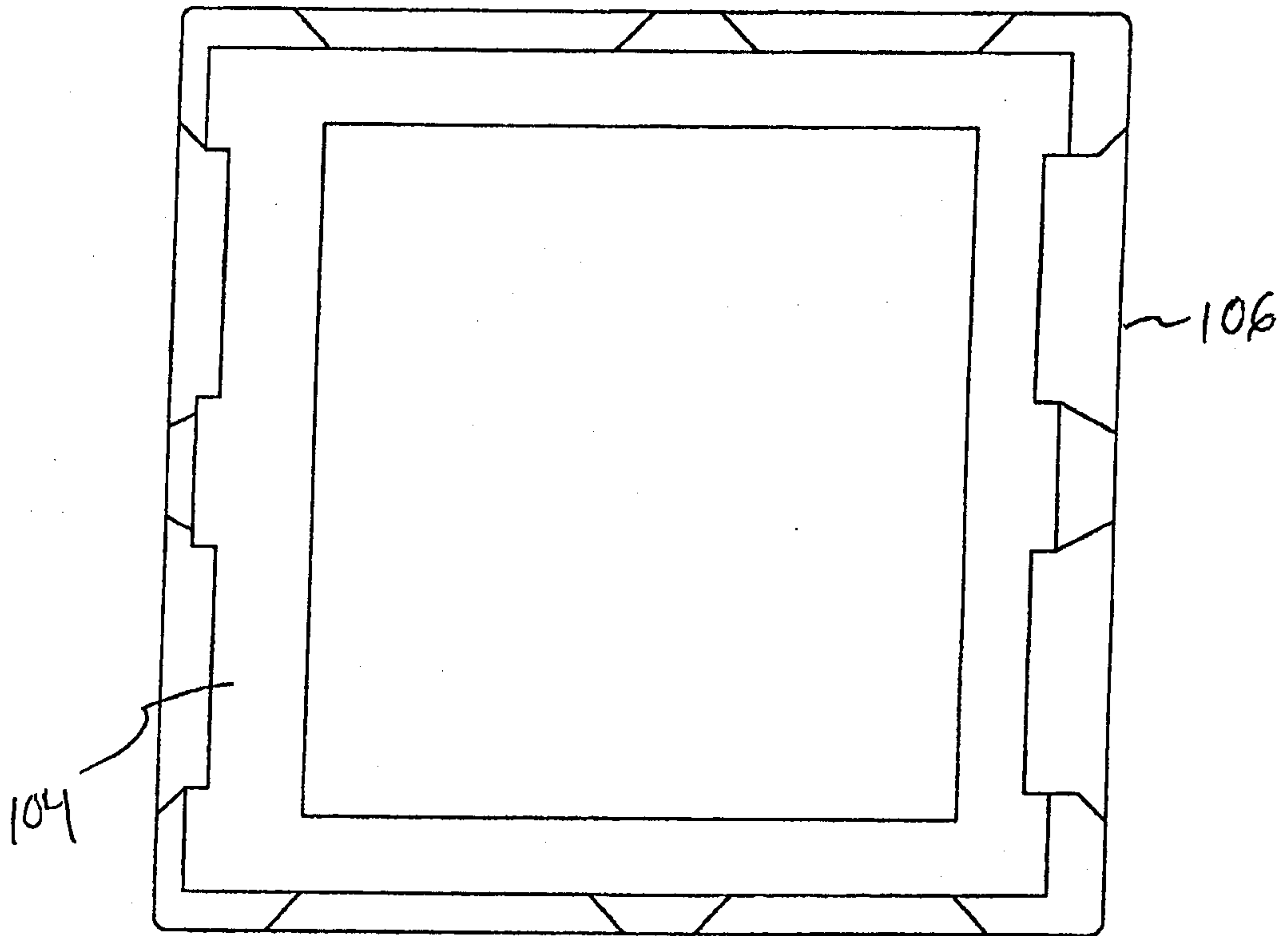

FIG. 12A

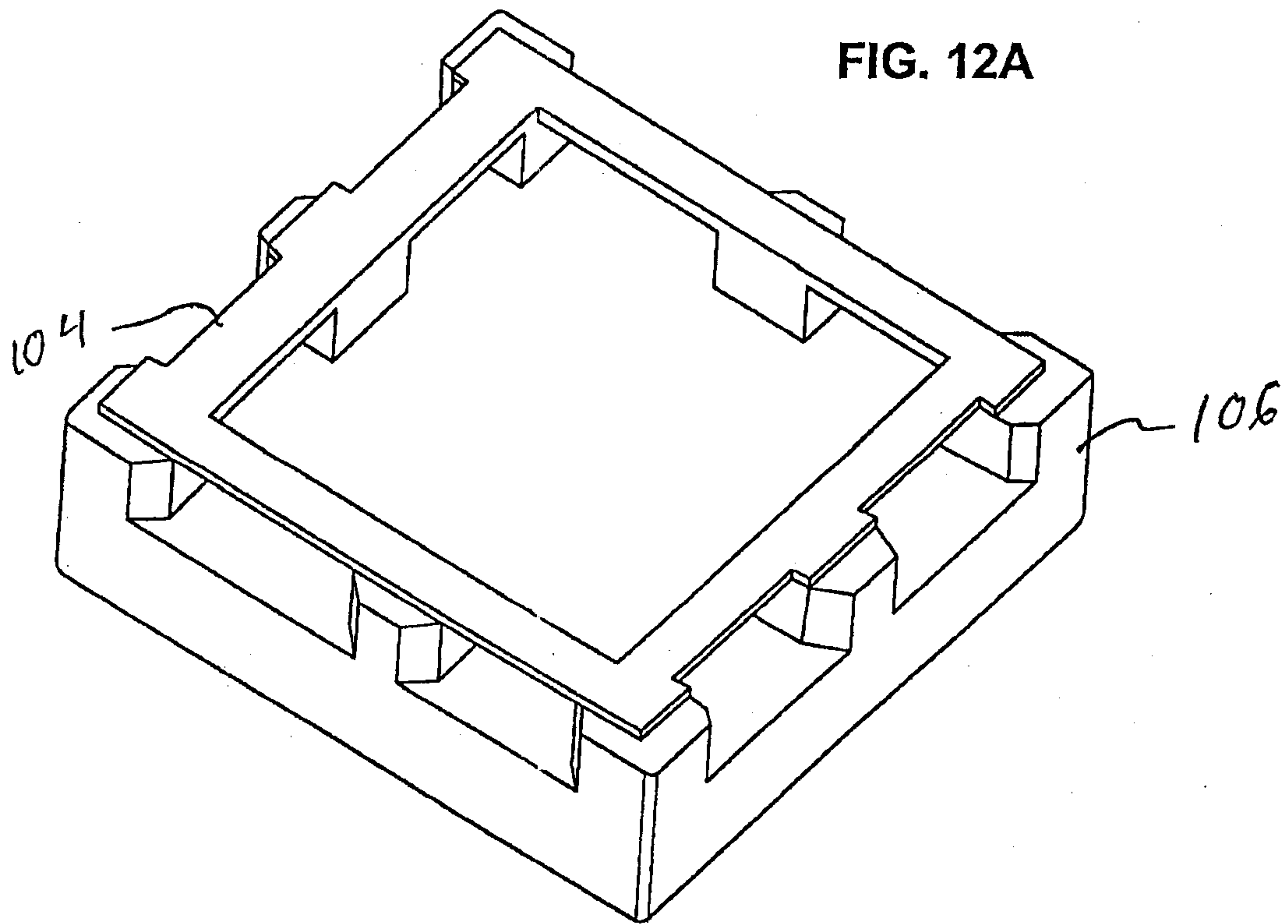

FIG. 12B

13/30

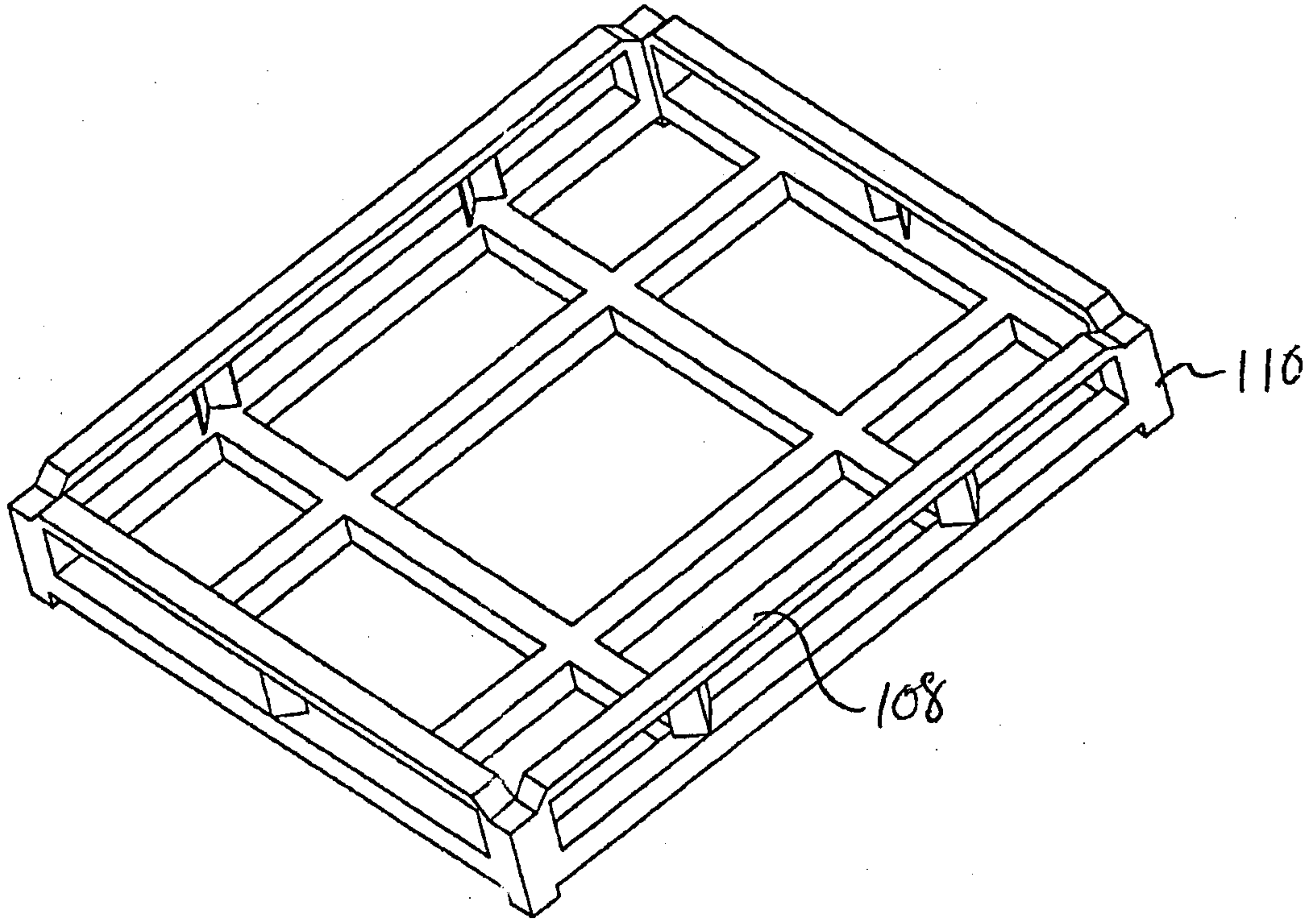

FIG. 13A

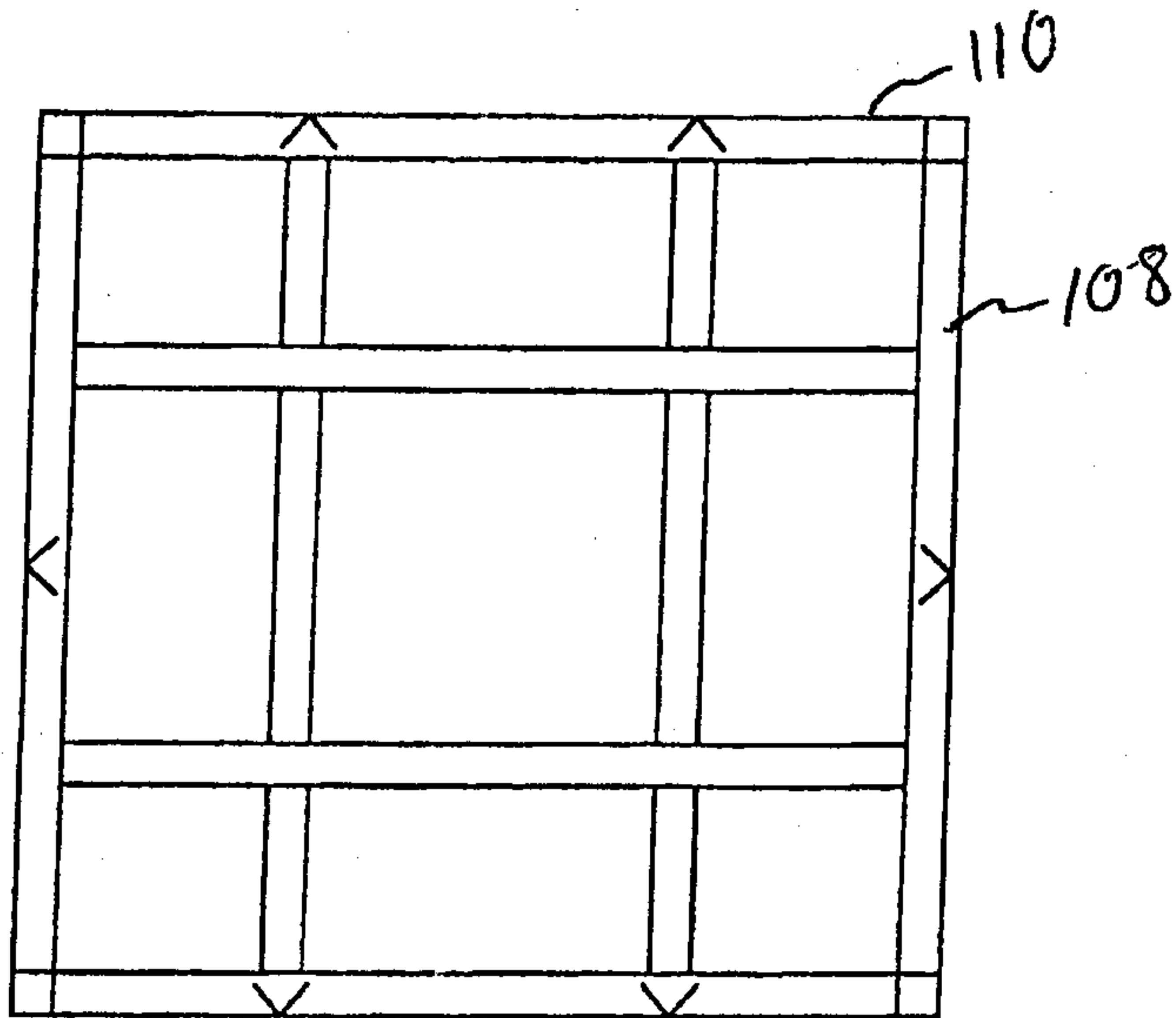

FIG. 13B

14/30

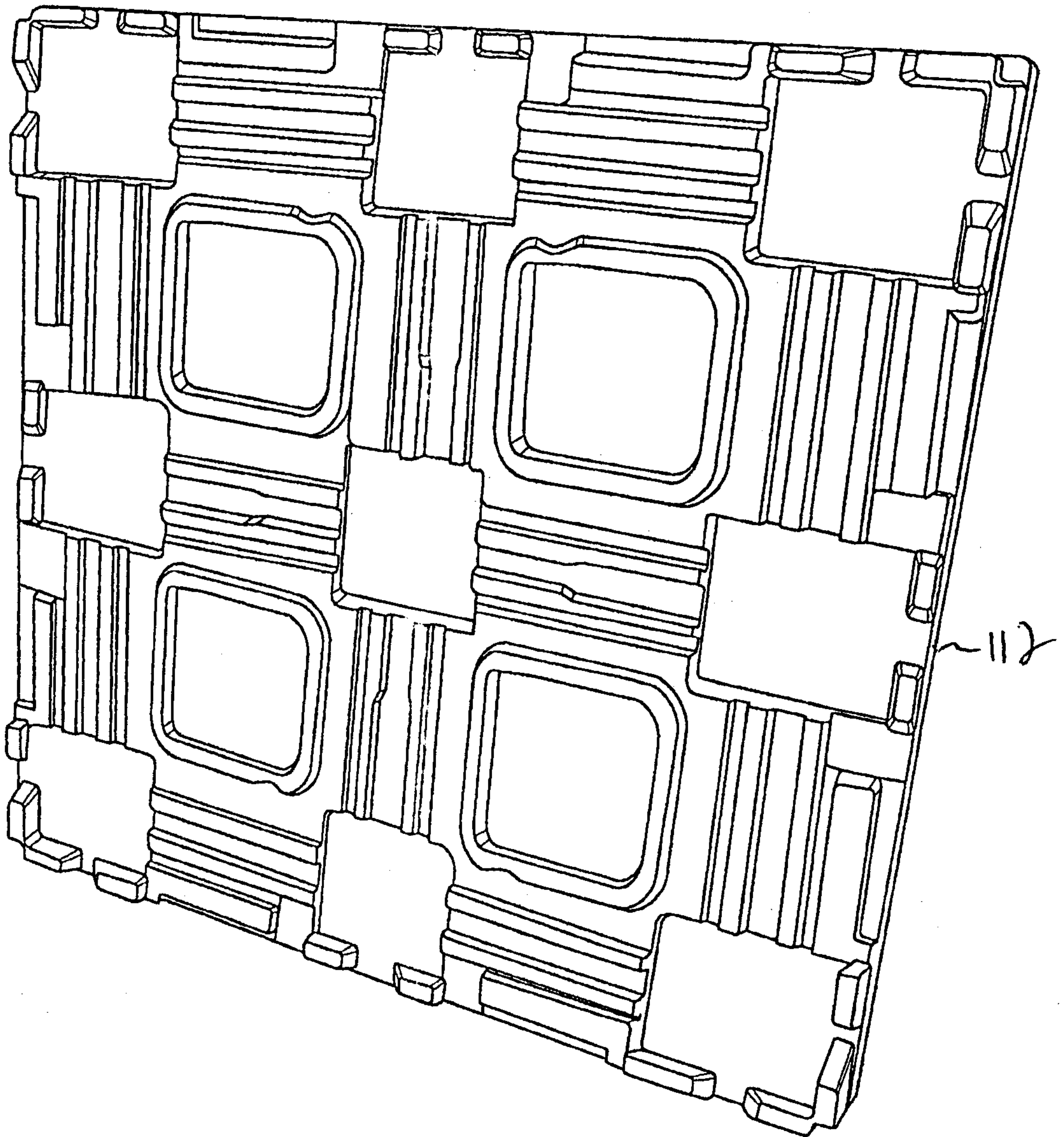
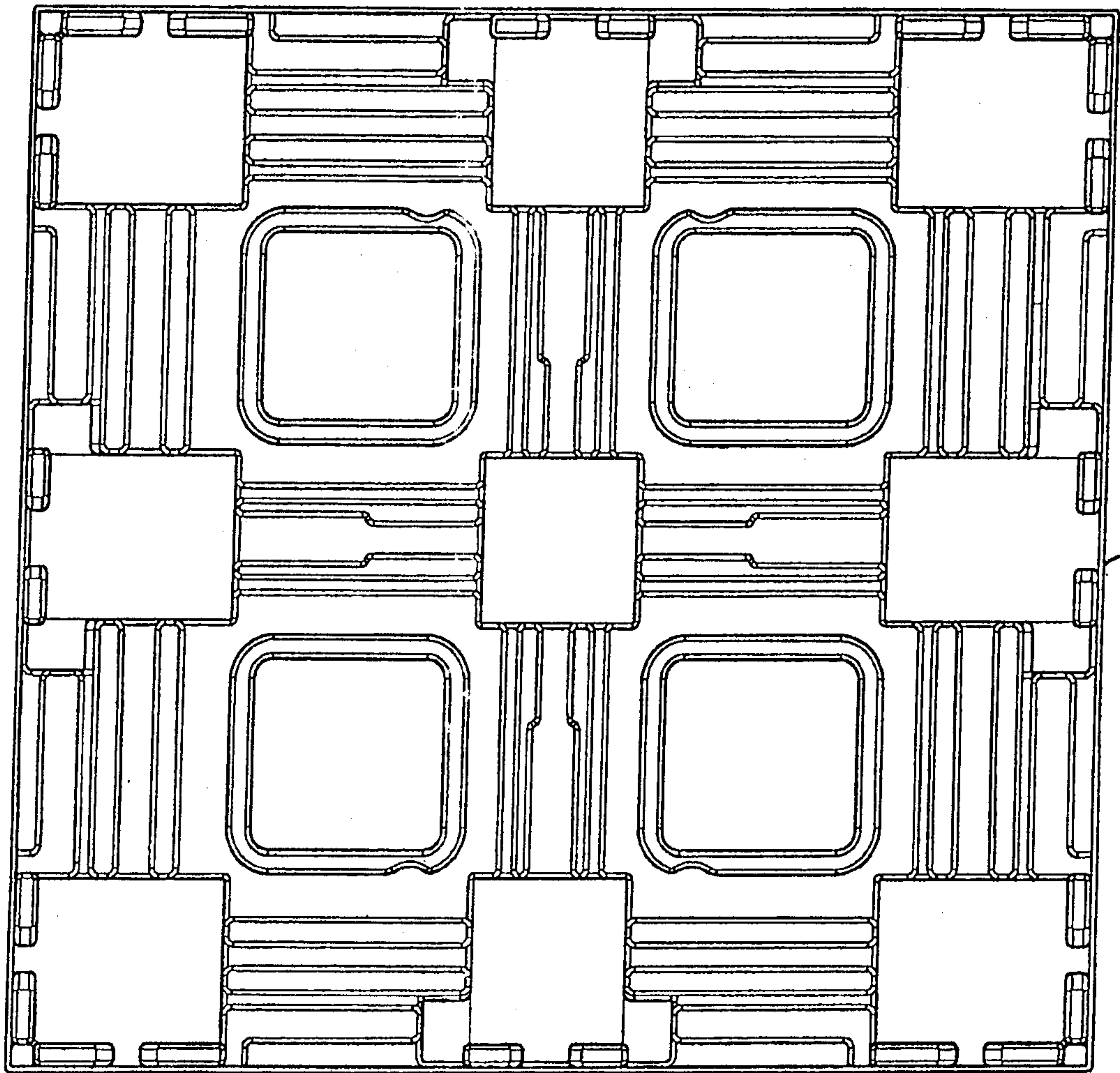

FIG. 14A

15/30



~112

FIG. 14B

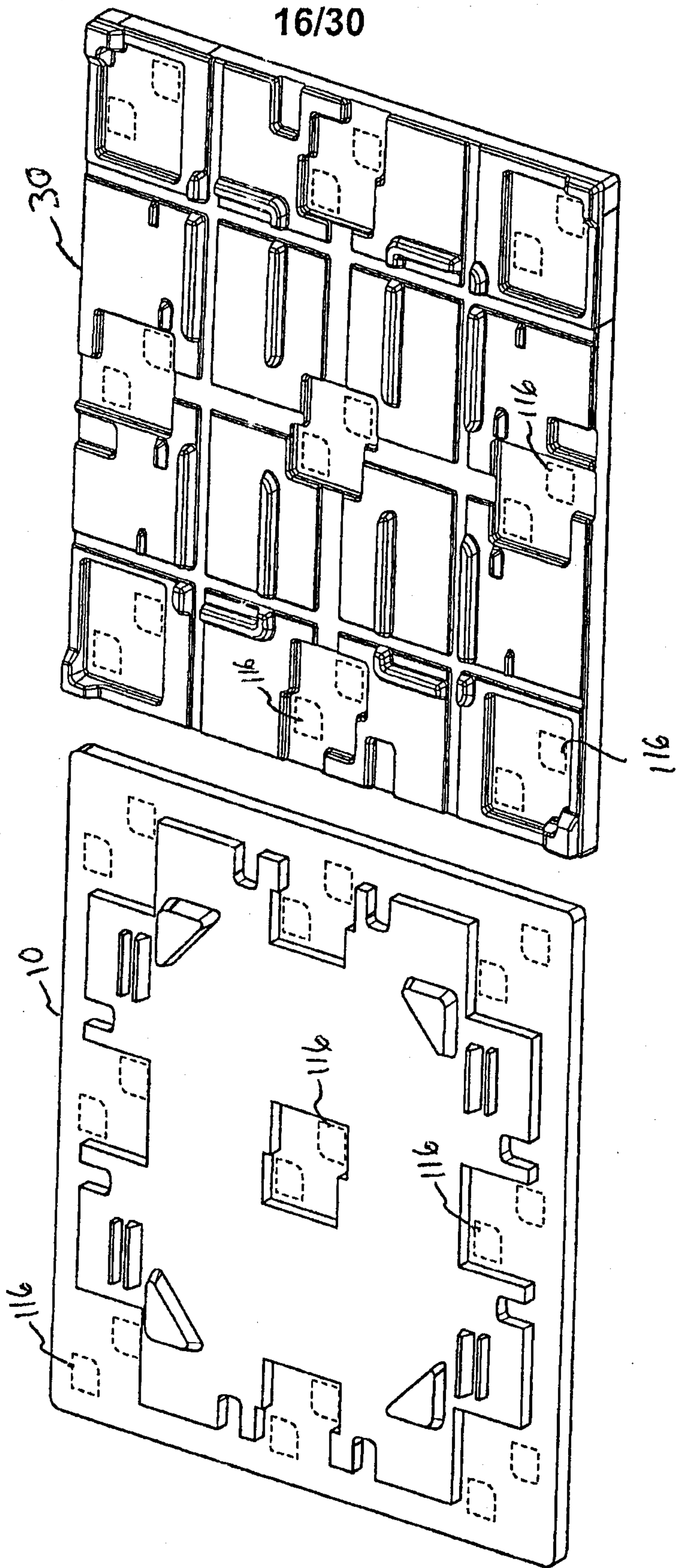

FIG. 15B

FIG. 15A

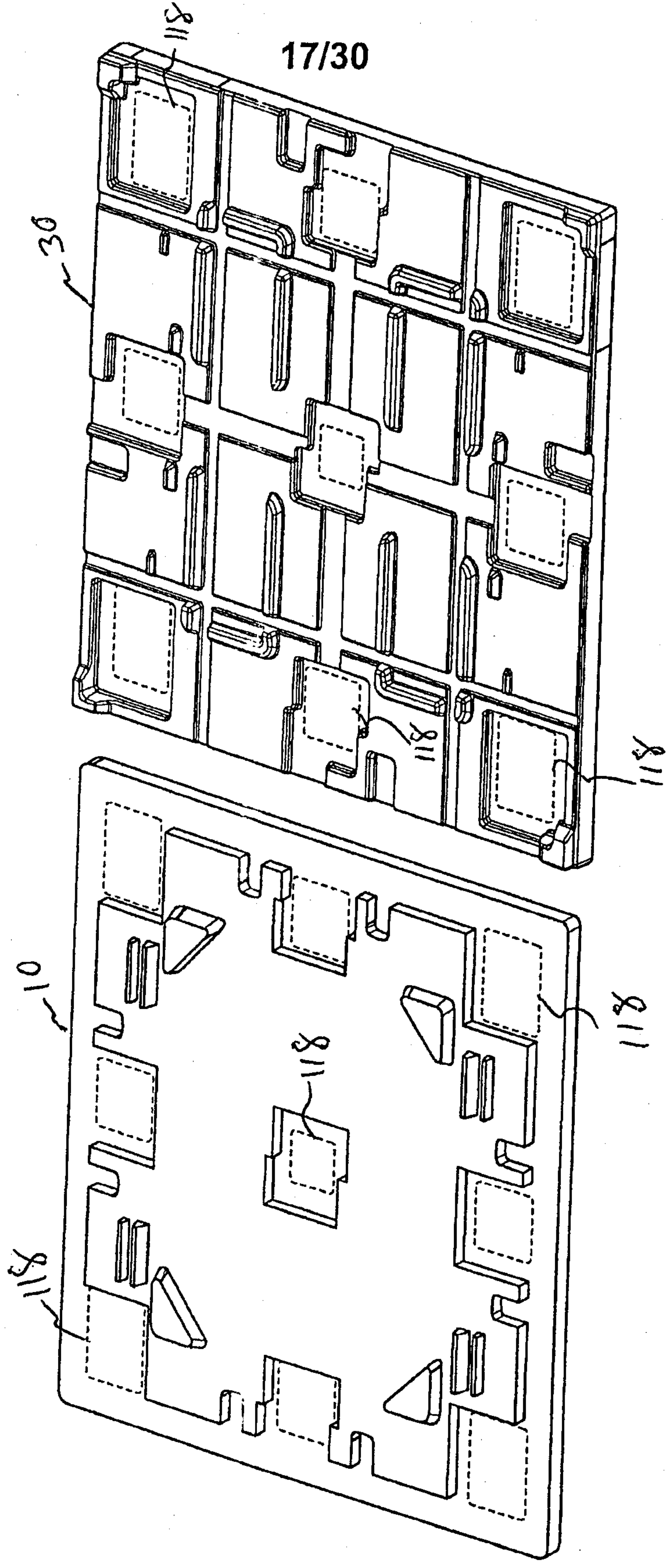

FIG. 16B

FIG. 16A

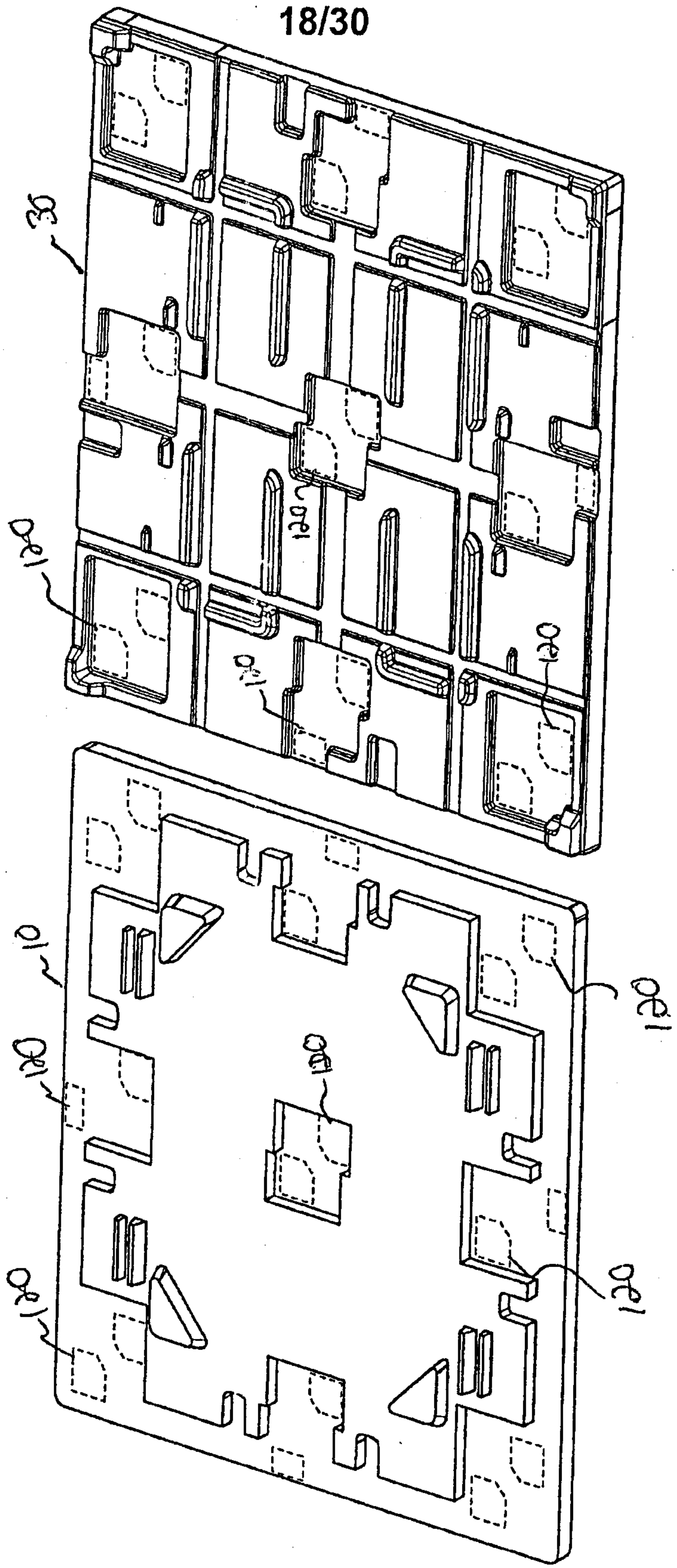

FIG. 17B

FIG. 17A

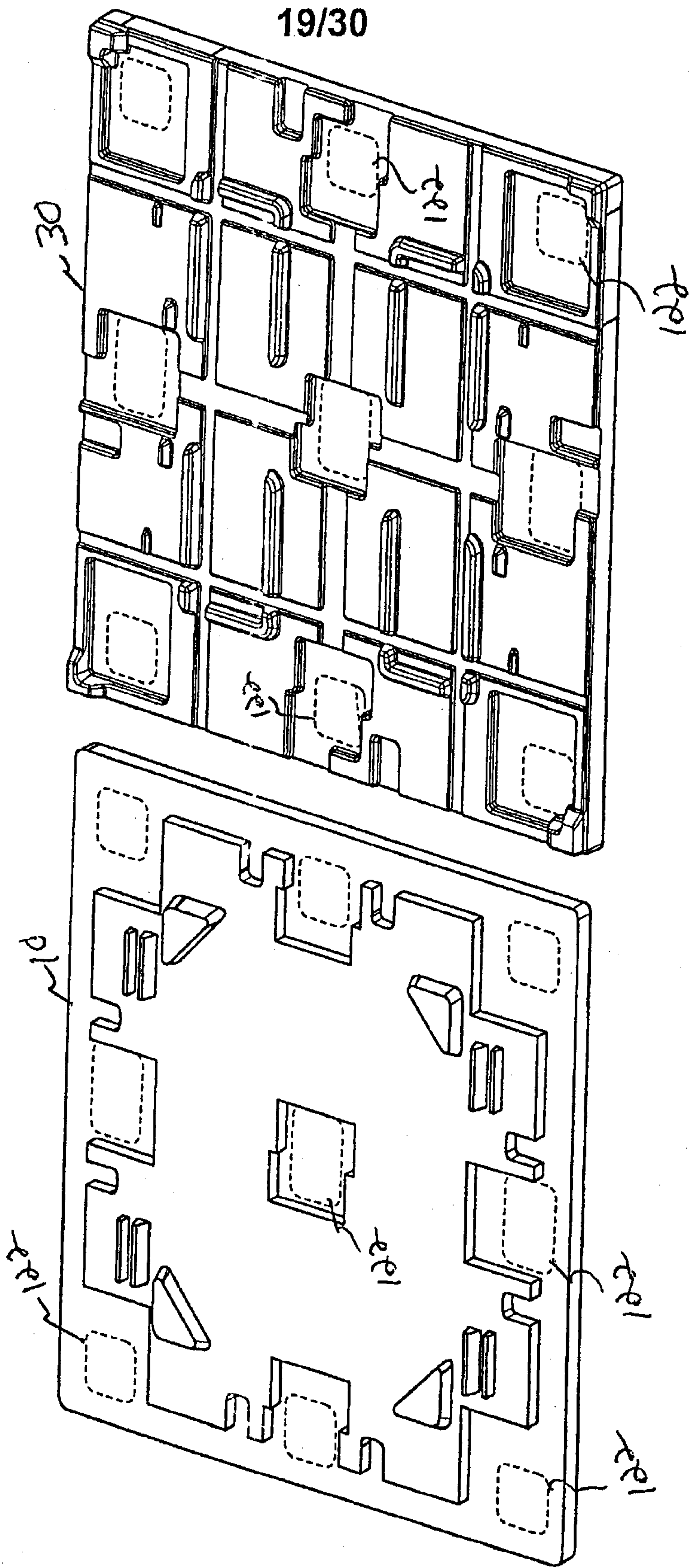

FIG. 18B

FIG. 18A

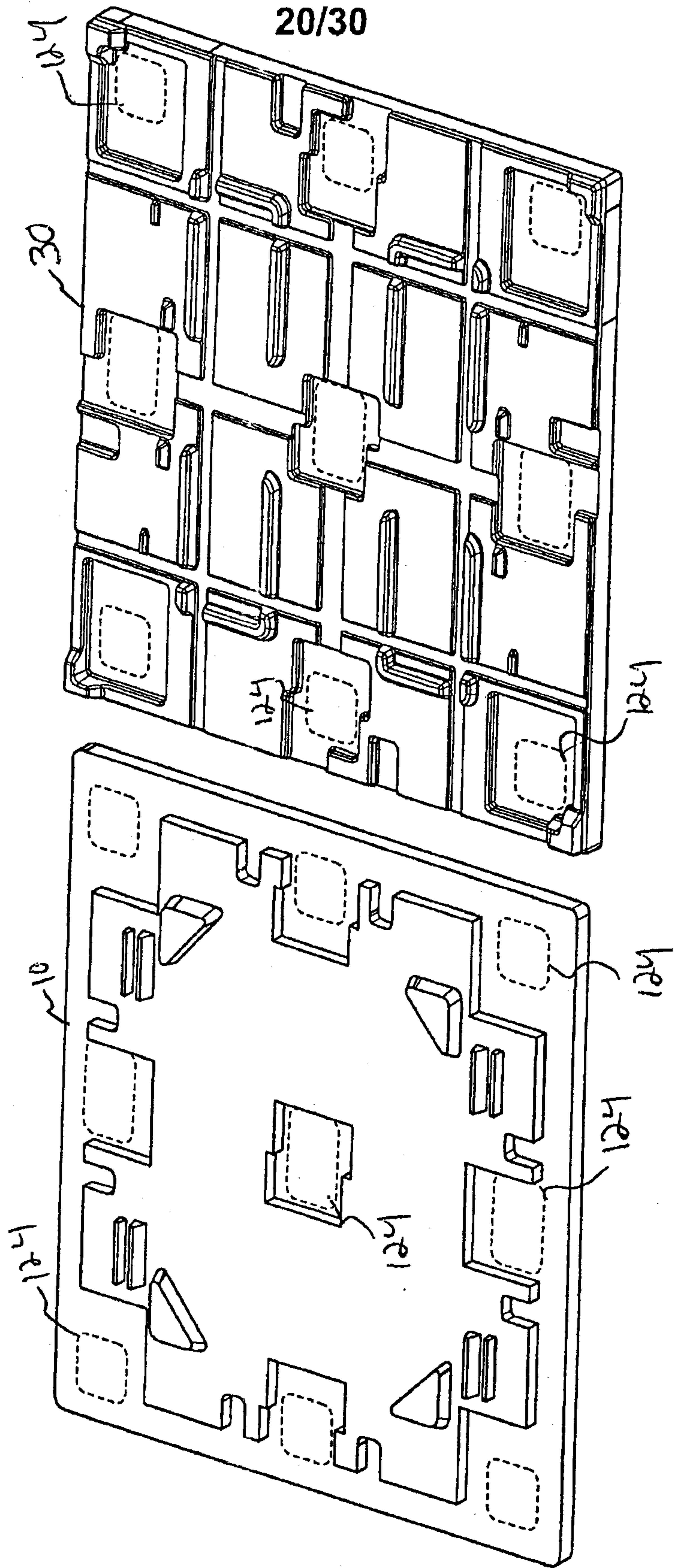

FIG. 19B

FIG. 19A

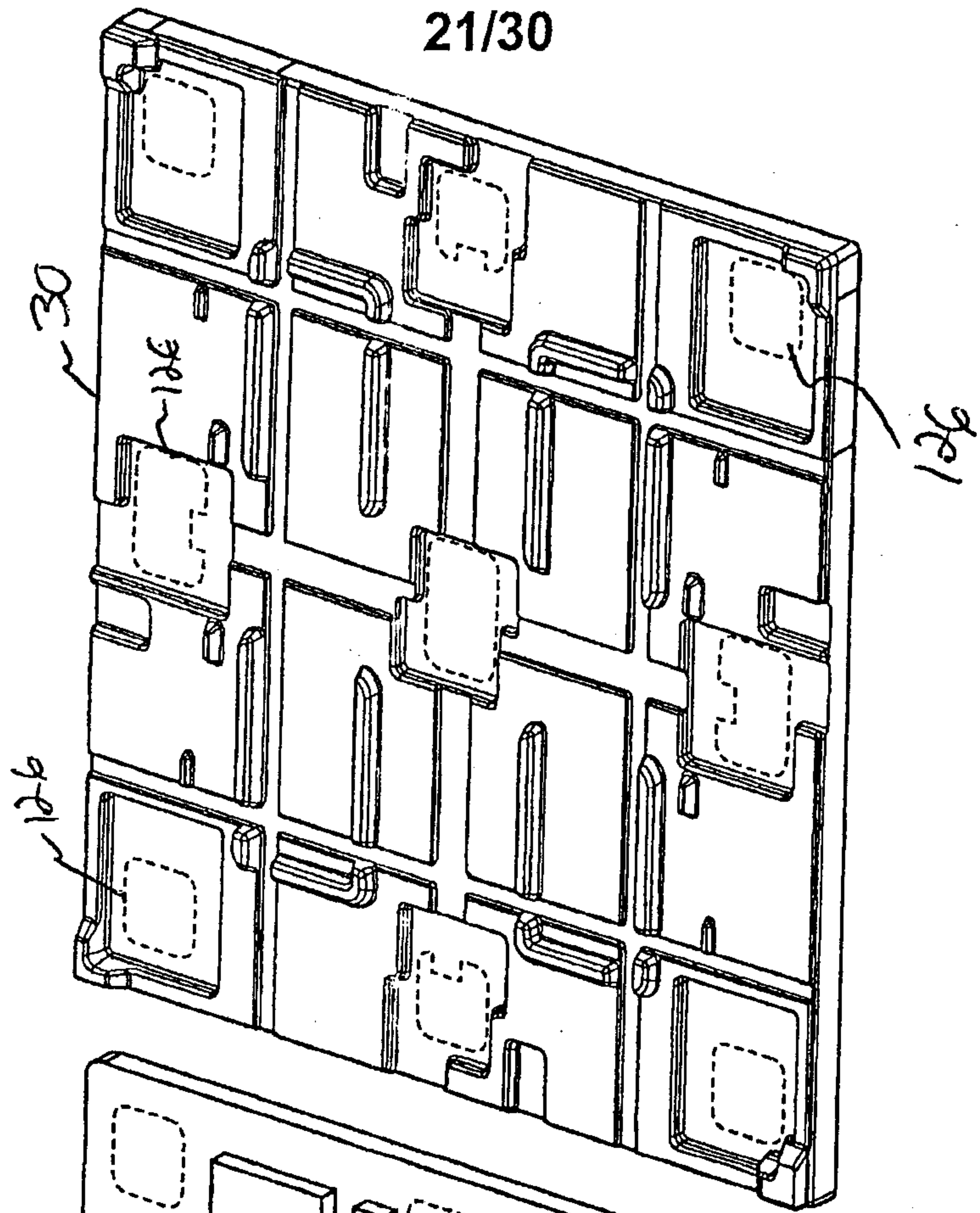

FIG. 20A

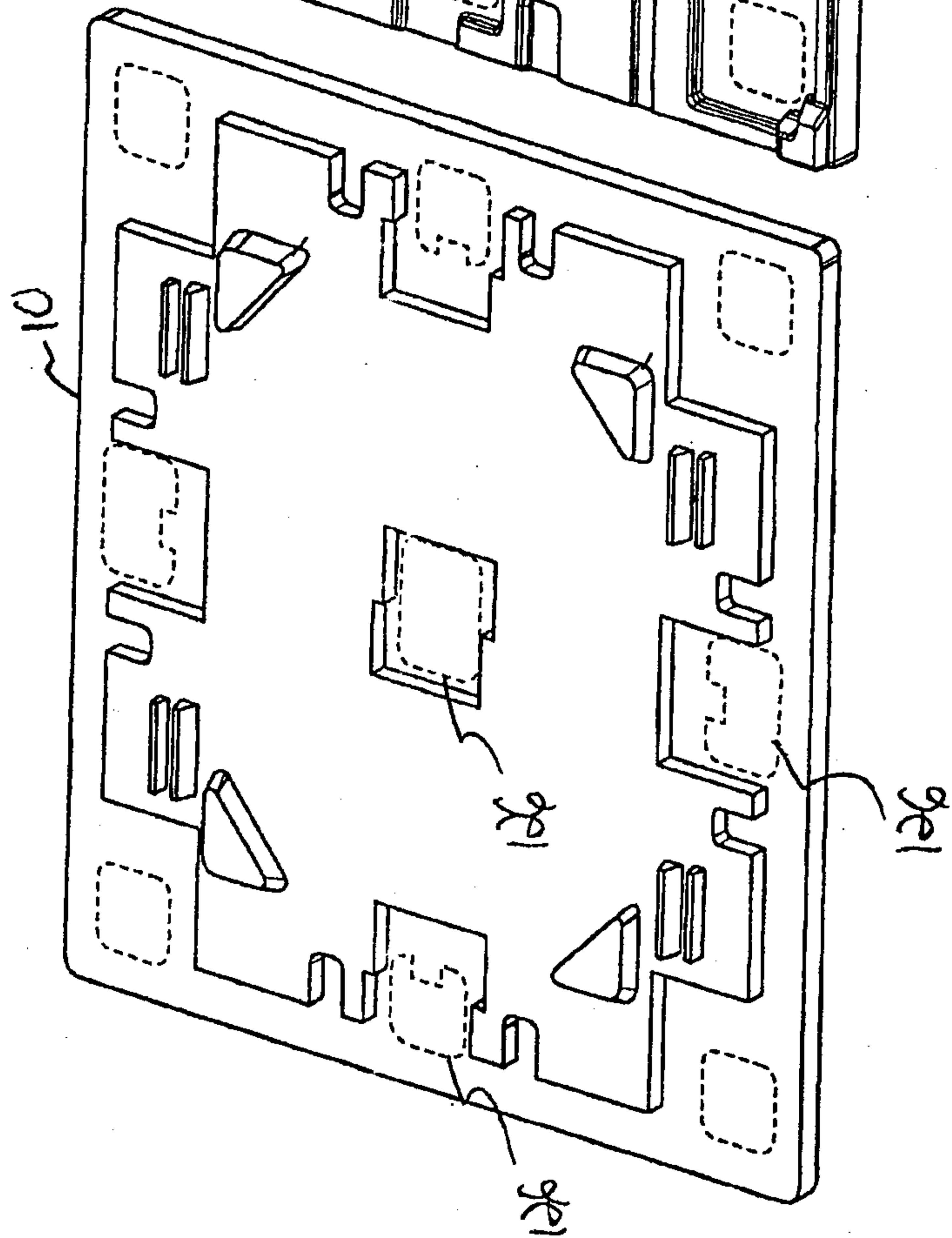

FIG. 20B

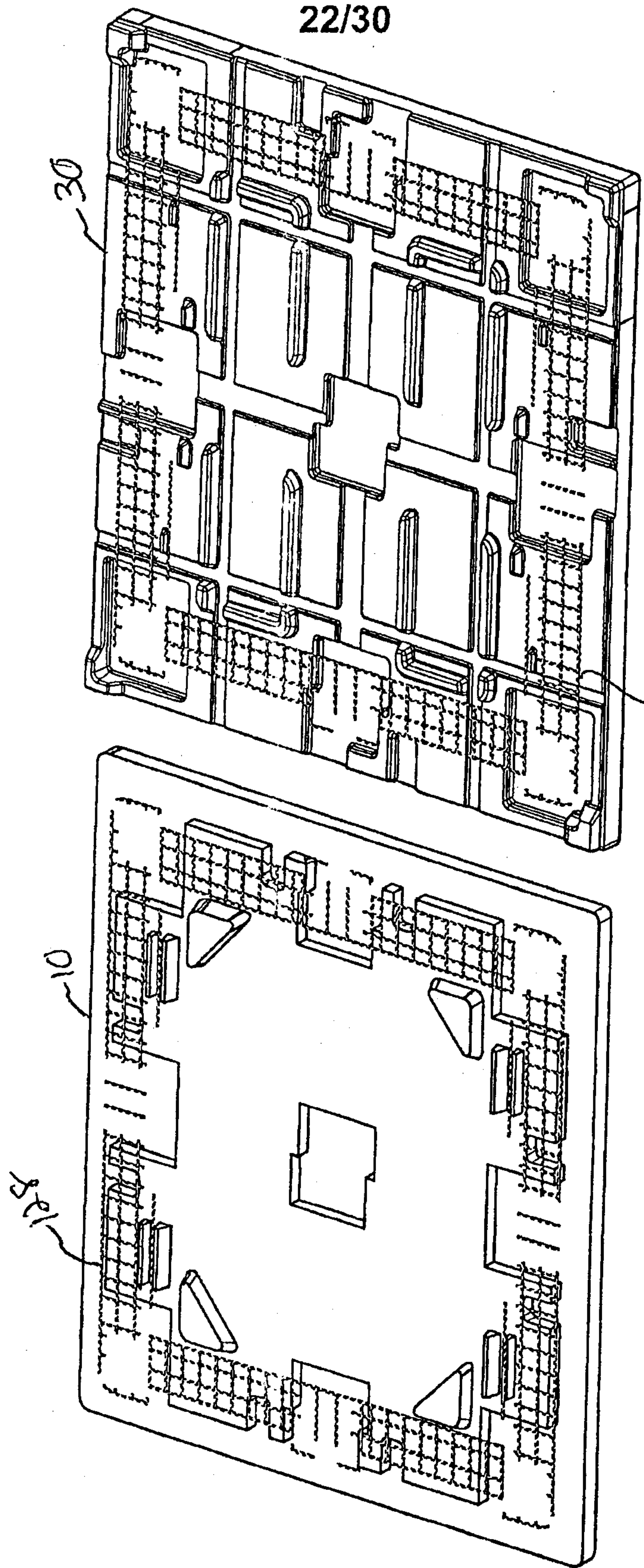

FIG. 21B

FIG. 21A

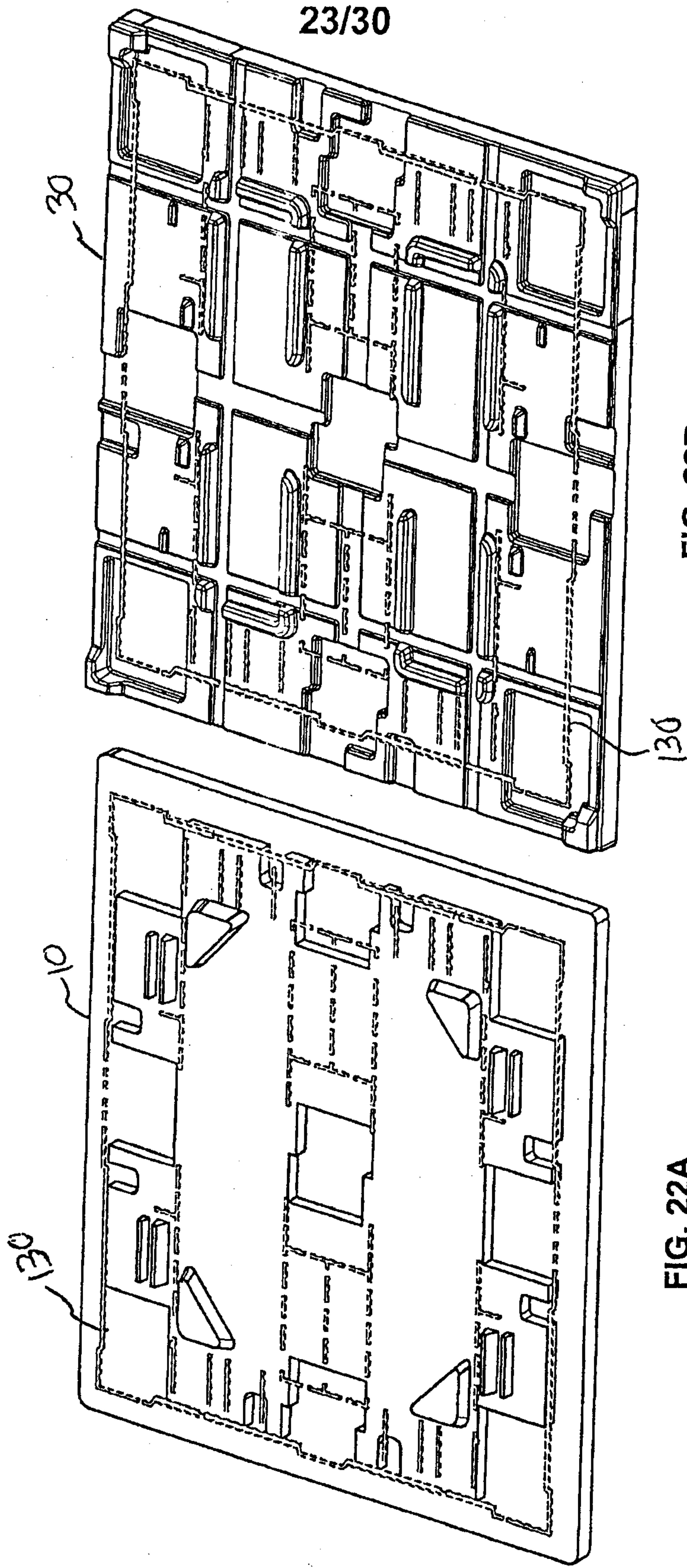

FIG. 22B

FIG. 22A

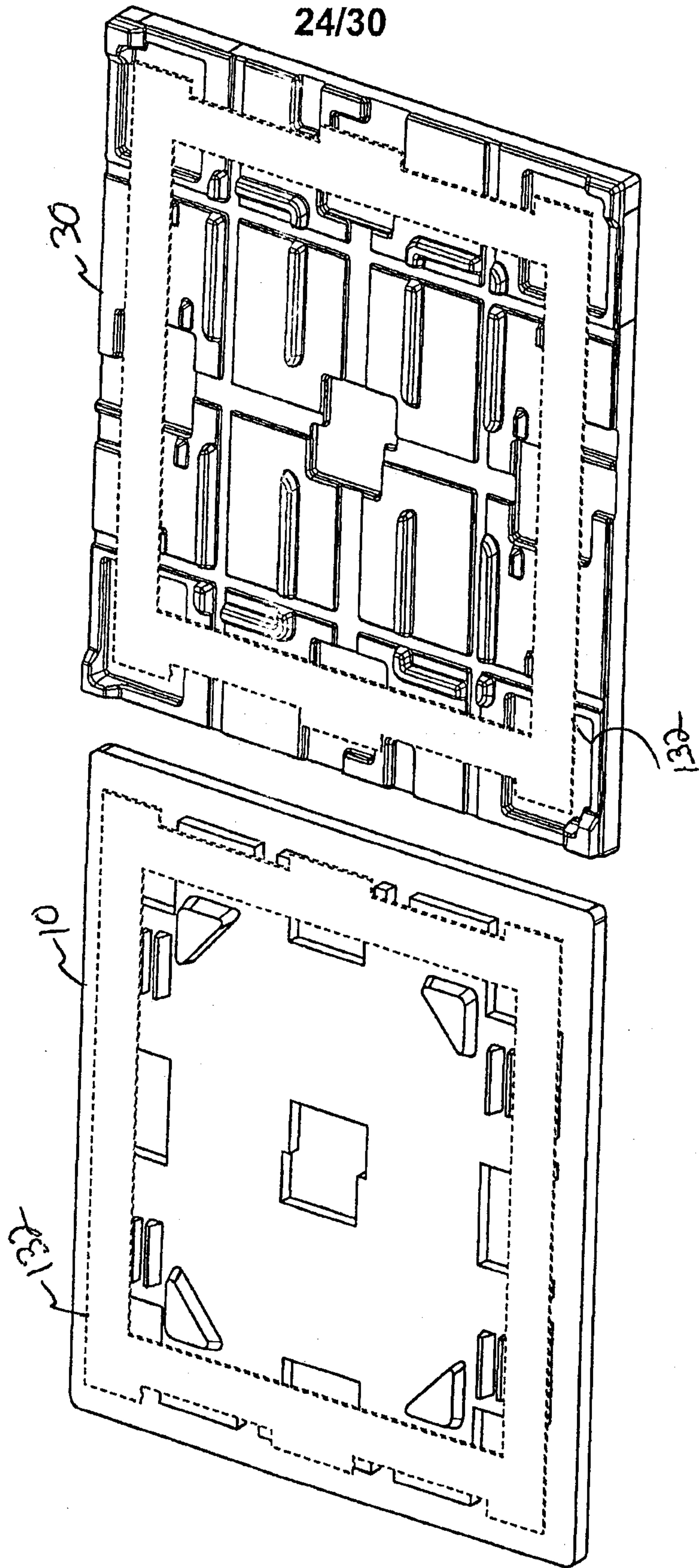

FIG. 23B

FIG. 23A

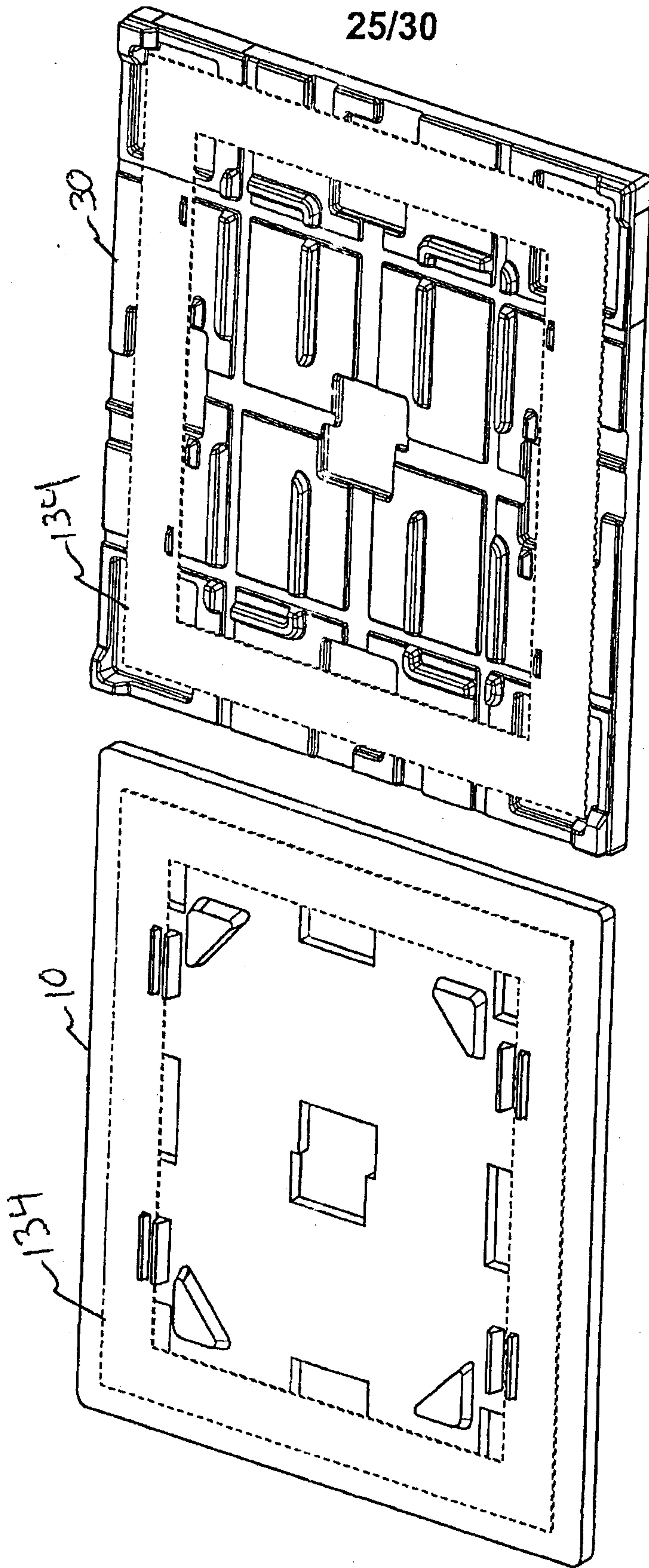

FIG. 24A

FIG. 24B

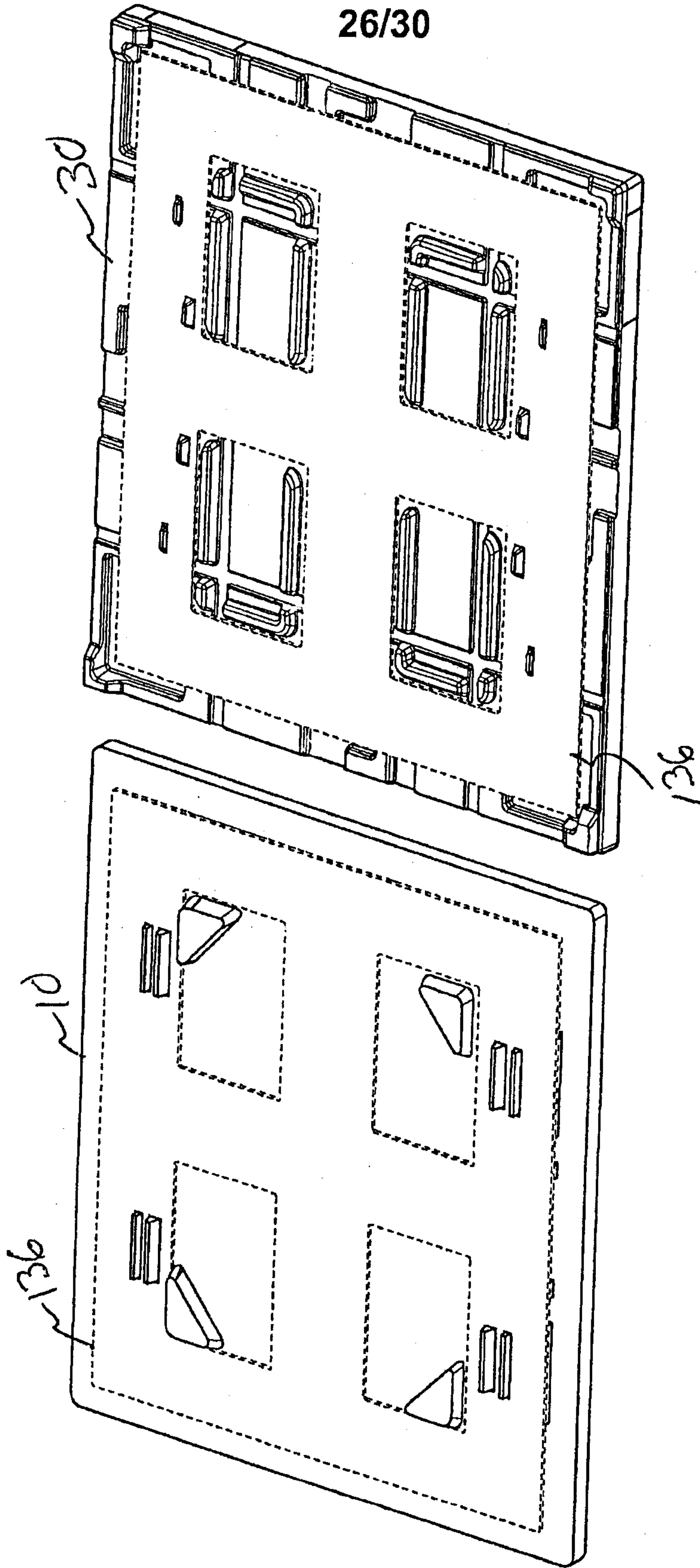

FIG. 25A

FIG. 25B

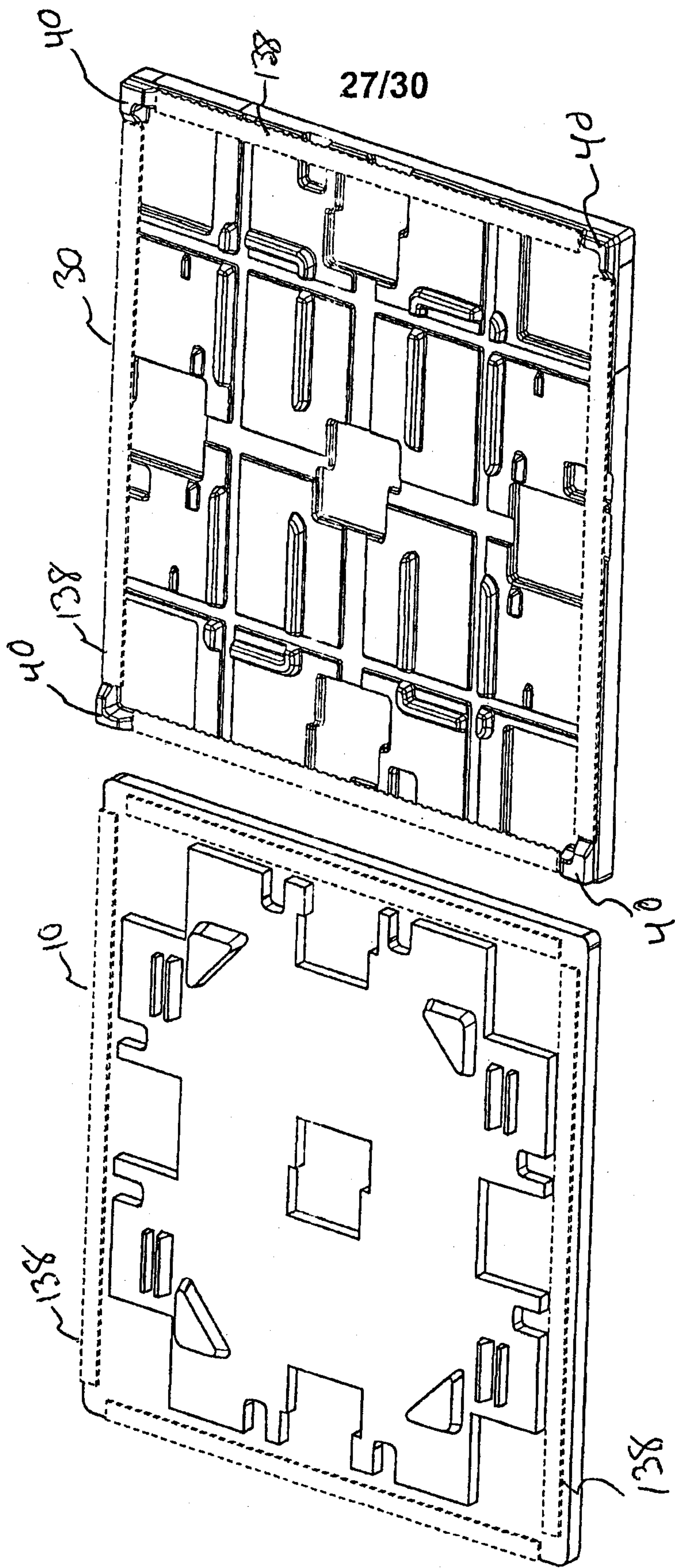

FIG. 26B

FIG. 26A

28/30

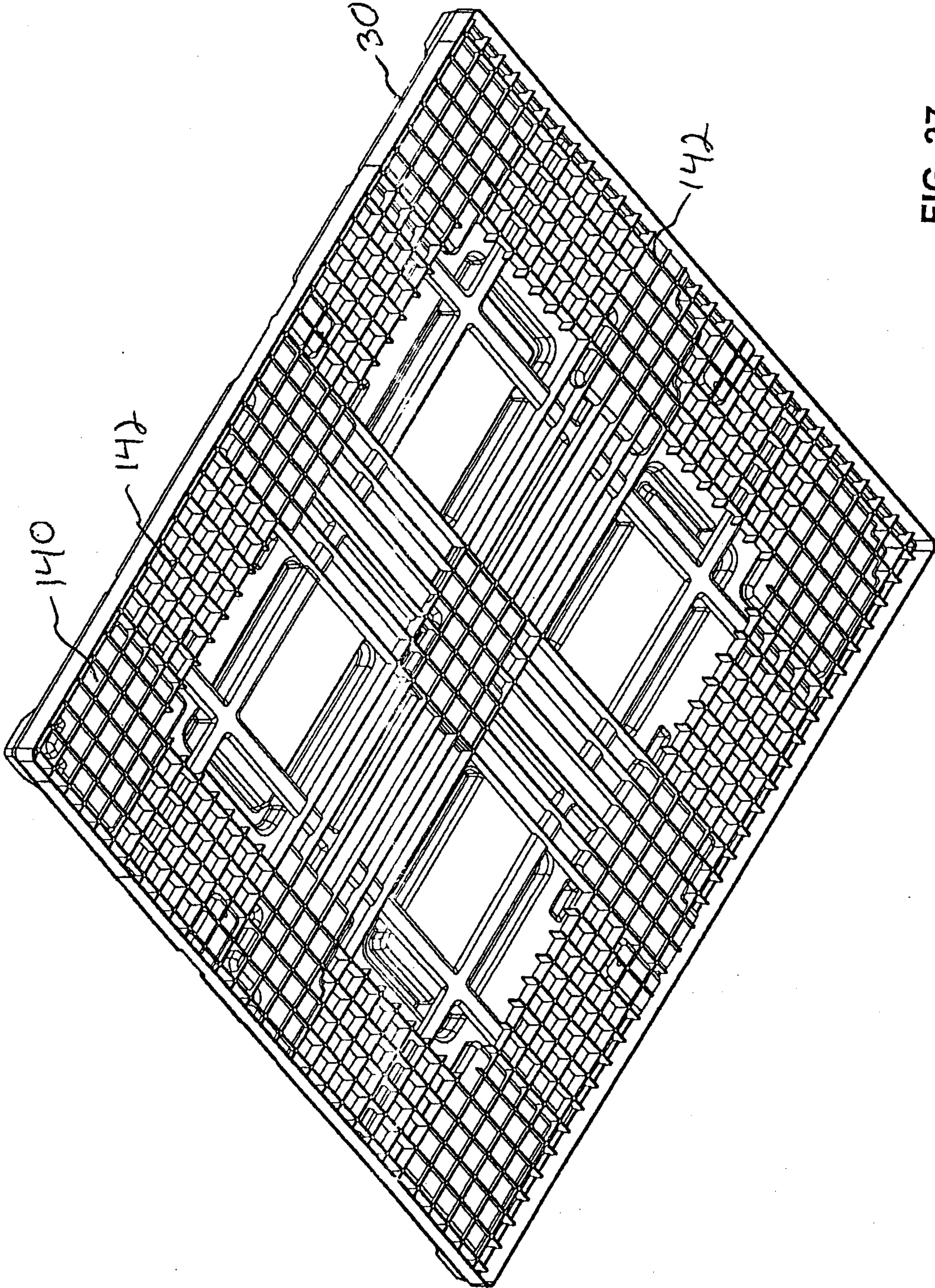

FIG. 27

29/30

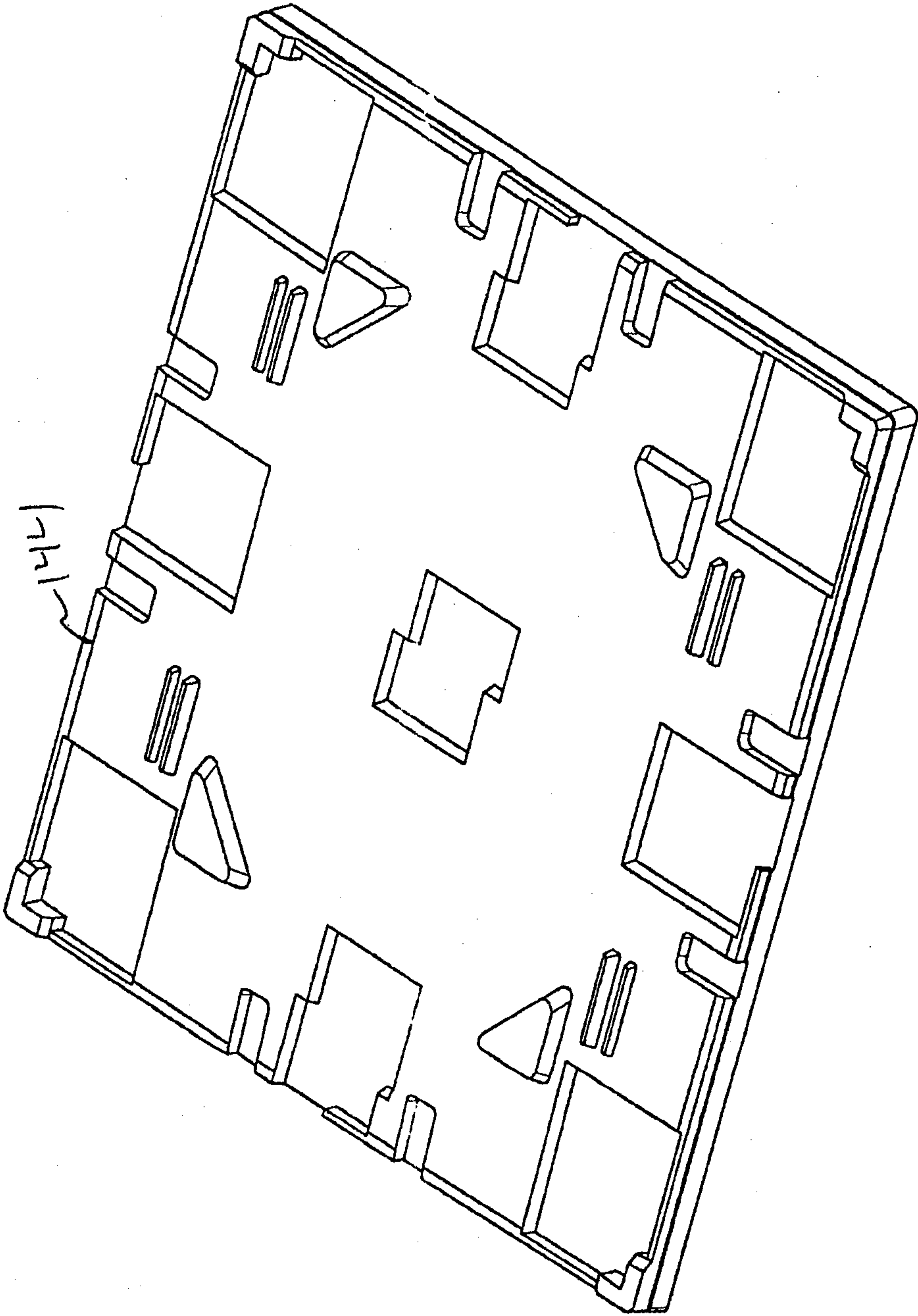

FIG. 28

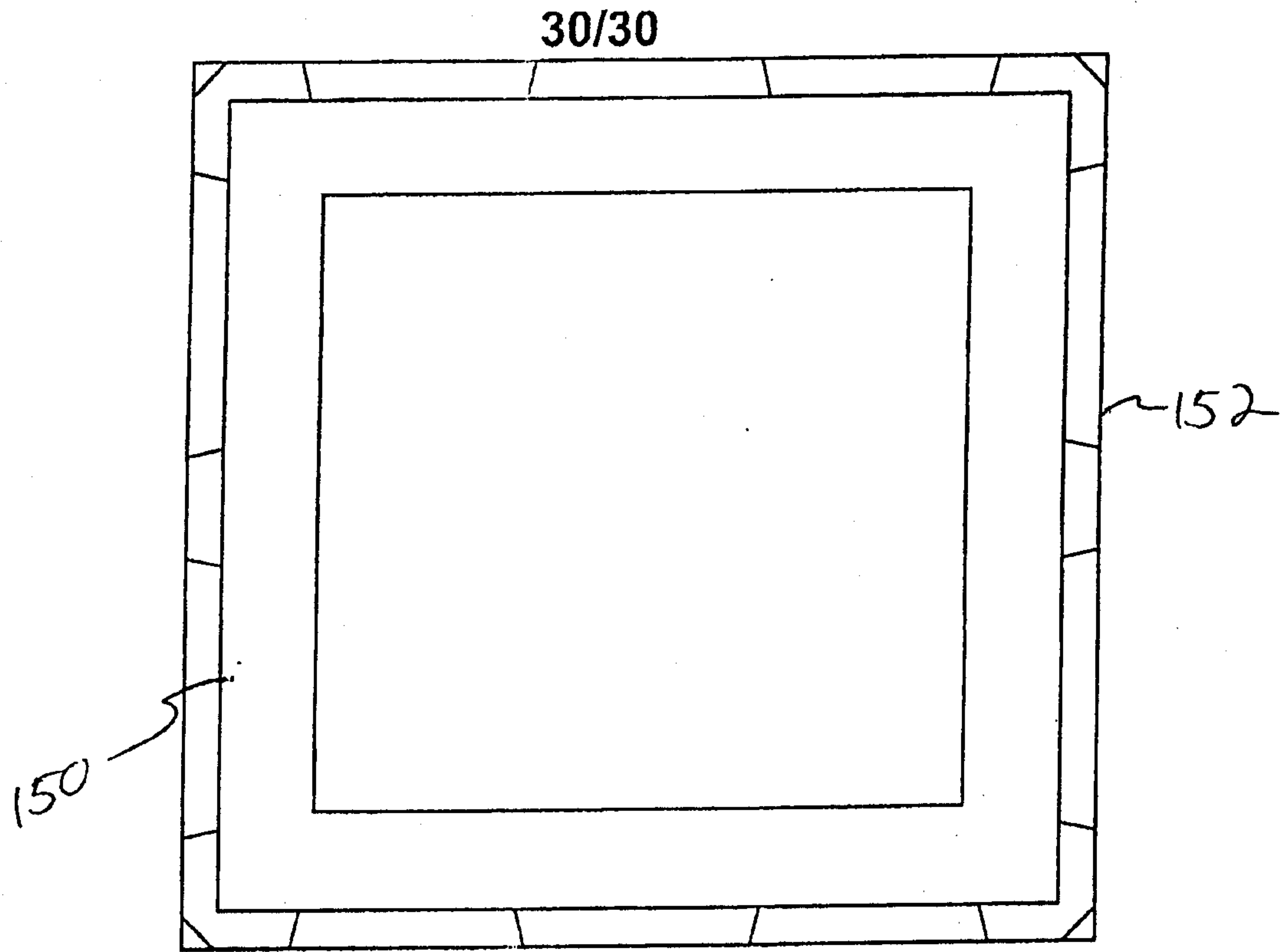

FIG. 29A

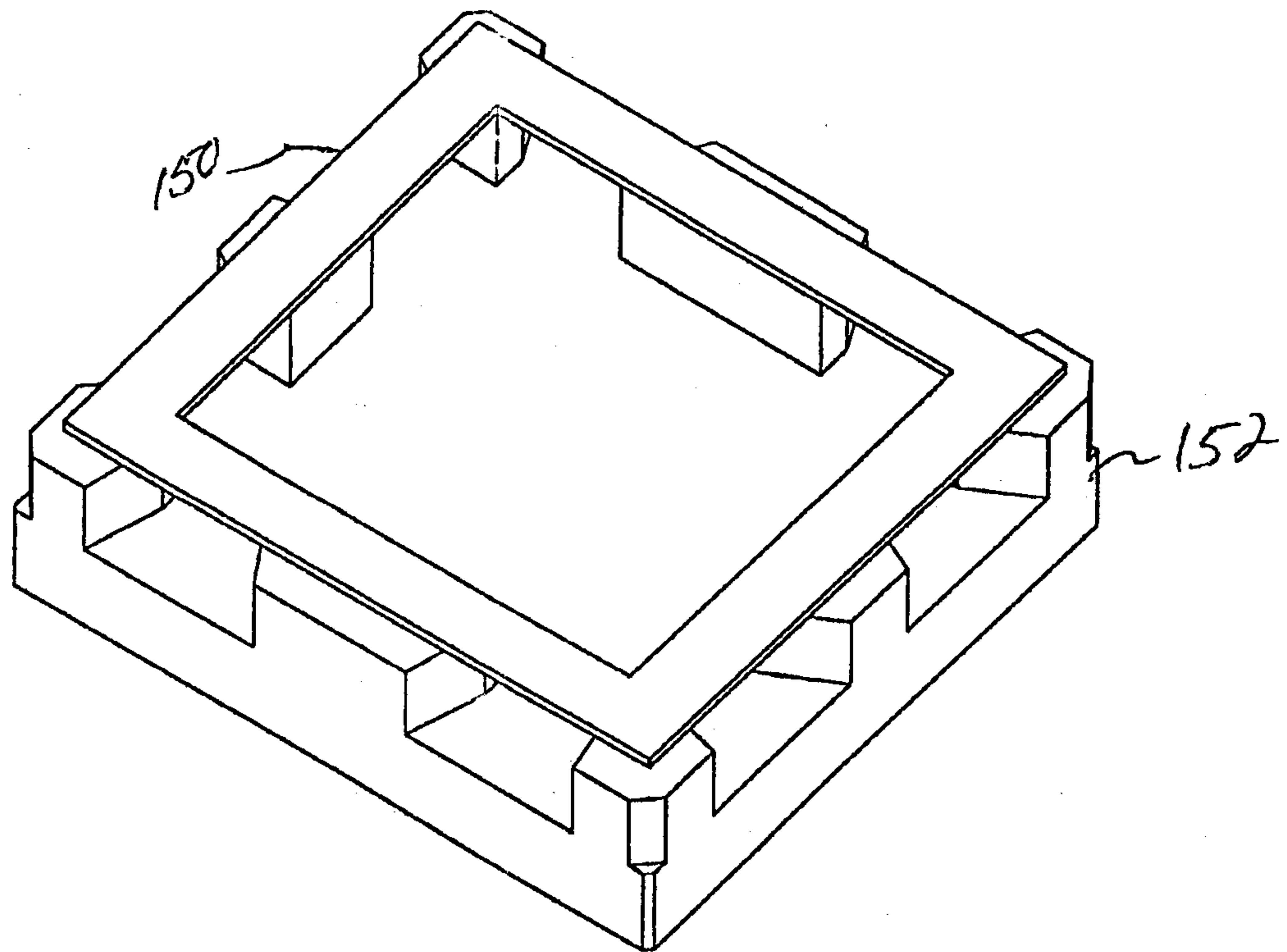

FIG. 29B

