



(51) International Patent Classification:

A24F 47/00 (2020.01) A61M 16/06 (2006.01)  
A61M 11/00 (2006.01)

(21) International Application Number:

PCT/CA2019/051631

(22) International Filing Date:

15 November 2019 (15.11.2019)

(25) Filing Language:

English

(26) Publication Language:

English

(30) Priority Data:

62/768,315 16 November 2018 (16.11.2018) US

(71) Applicant: **HEXO OPERATIONS INC.** [CA/CA]; 3000 Solandt Road, Ottawa, Ontario, K2K 2X2 (CA).

(72) Inventors: **WOODS, Patrick**; c/o Hexo Operations Inc., 490 Boul. St-Joseph, Suite 204, Gatineau, Québec J8Y 3Y7 (CA). **ALSAYAR, Max**; c/o Hexo Operations Inc., 490 Boul. St-Joseph, Suite 204, Gatineau, Québec J8Y 3Y7 (CA).

(74) Agent: **SMART & BIGGAR LLP**; P.O. Box 2999, Station D., 900-55 Metcalfe Street, Ottawa, Ontario K1P 5Y6 (CA).

(81) Designated States (unless otherwise indicated, for every kind of national protection available):

AE, AG, AL, AM, AO, AT, AU, AZ, BA, BB, BG, BH, BN, BR, BW, BY, BZ, CA, CH, CL, CN, CO, CR, CU, CZ, DE, DJ, DK, DM, DO, DZ, EC, EE, EG, ES, FI, GB, GD, GE, GH, GM, GT, HN, HR, HU, ID, IL, IN, IR, IS, JO, JP, KE, KG, KH, KN, KP, KR, KW, KZ, LA, LC, LK, LR, LS, LU, LY, MA, MD, ME, MG, MK, MN, MW, MX, MY, MZ, NA, NG, NI, NO, NZ, OM, PA, PE, PG, PH, PL, PT, QA, RO, RS, RU, RW, SA, SC, SD, SE, SG, SK, SL, SM, ST, SV, SY, TH, TJ, TM, TN, TR, TT, TZ, UA, UG, US, UZ, VC, VN, ZA, ZM, ZW.

(84) Designated States (unless otherwise indicated, for every kind of regional protection available):

ARIPO (BW, GH, GM, KE, LR, LS, MW, MZ, NA, RW, SD, SL, ST, SZ, TZ, UG, ZM, ZW), Eurasian (AM, AZ, BY, KG, KZ, RU, TJ, TM), European (AL, AT, BE, BG, CH, CY, CZ, DE, DK, EE, ES, FI, FR, GB, GR, HR, HU, IE, IS, IT, LT, LU, LV, MC, MK, MT, NL, NO, PL, PT, RO, RS, SE, SI, SK, SM, TR), OAPI (BF, BJ, CF, CG, CI, CM, GA, GN, GQ, GW, KM, ML, MR, NE, SN, TD, TG).

(54) Title: APPARATUS AND METHODS FOR MULTI-CHAMBER VAPORIZATION DEVICES WITH VAPORIZATION SUBSTANCE MIXING

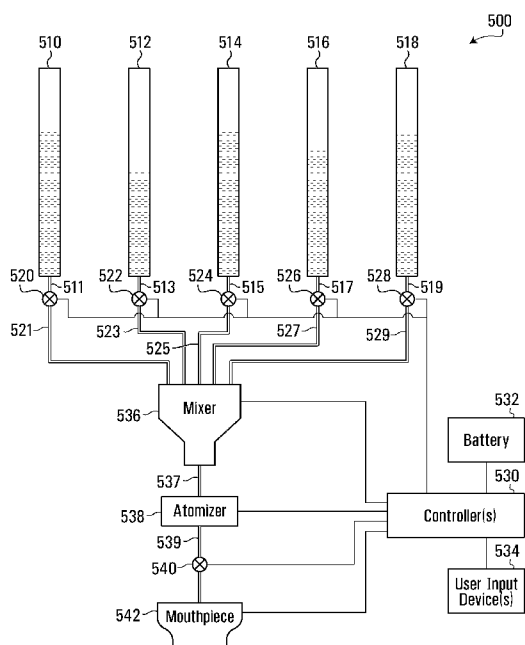

FIG. 5

(57) Abstract: A vaporization device includes a mixer to receive and mix vaporization substances to form a vaporization substance mixture, and an atomizer, in fluid communication with the mixer, to vaporize the vaporization substance mixture. The mixer is an active mixer in some embodiments, and could include a stirring element such as a stirring element that is driven by an electric motor, a magnetic stirring element, or an acoustic stirring element. The mixer could also or instead include a passive mixer with multiple mixing elements to mix the vaporization substances and form the vaporization substance mixture.

WO 2020/097736 A1

**Published:**

- *with international search report (Art. 21(3))*
- *in black and white; the international application as filed contained color or greyscale and is available for download from PATENTSCOPE*

APPARATUS AND METHODS FOR MULTI-CHAMBER VAPORIZATION DEVICES  
WITH VAPORIZATION SUBSTANCE MIXING

**CROSS-REFERENCE TO RELATED APPLICATION**

[0001] This application is related to, and claims priority to, United States Provisional  
5 Patent Application No. 62/768,315, entitled “APPARATUS AND METHODS FOR MULTI-  
CHAMBER VAPORIZATION DEVICES WITH VAPORIZATION SUBSTANCE  
MIXING”, and filed on November 16, 2018, the entire contents of which are incorporated by  
reference herein.

**FIELD**

10 [0002] This application relates generally to vaporization devices, and in particular to  
multi-chamber vaporization devices with mixing of vaporization substances before  
vaporization.

**BACKGROUND**

[0003] A vaporization device is used to vaporize substances for inhalation. These  
15 substances are referred to herein as vaporization substances, and could include, for example,  
cannabis products, tobacco products, herbs, and/or flavorants. In some cases, active  
substances in cannabis, tobacco, or other plants or materials extracted to generate concentrates  
are used as vaporization substances. These substances could include cannabinoids from  
cannabis, and nicotine from tobacco. In other cases, synthetic substances are artificially  
20 manufactured. Terpenes are common flavorant vaporization substances and could be  
generated from natural essential oils or artificially.

[0004] Vaporization substances could be in the form of loose leaf in the case of cannabis,  
tobacco, and herbs, for example, or in the form of concentrates or derivative products such as  
liquids, waxes, or gels, for example. Vaporization substances, whether intended for flavor or  
25 some other effect, could be mixed with other compounds such as propylene glycol, glycerin,

medium chain triglyceride (MCT) oil and/or water to adjust the viscosity of a final vaporization substance.

[0005] In a vaporization device, the vaporization substance is heated to the vaporization point of one or more constituent ingredients or substances. This produces a vapor, which may also be referred to as an aerosol. The vapor is then inhaled by a user through an air channel that is provided in the vaporization device, and often through a hose or pipe that is part of or attached to the vaporization device.

### **SUMMARY**

[0006] Conventional vaporization devices include a single chamber for storing a vaporization substance. However, vaporization devices with multiple chambers for storing vaporization substances could be desirable. For example, multiple chambers could include different vaporization substances for mixing before vaporization.

[0007] According to an aspect of the present disclosure, an apparatus includes a mixer to receive and actively mix vaporization substances to form a vaporization substance mixture; and an atomizer, in fluid communication with the mixer, to vaporize the vaporization substance mixture.

[0008] Such an apparatus could also include chambers to store respective vaporization substances.

[0009] A channel in fluid communication with the atomizer could also be provided in such an apparatus.

[0010] In an embodiment, an apparatus also includes a mouthpiece in fluid communication with the channel.

[0011] The chambers could include a chamber with an engagement structure to engage with a complementary engagement structure of the apparatus.

[0012] At least one of the vaporization substances is a liquid in some embodiments.

**[0013]** In another embodiment, at least one of the vaporization substances is a dry substance.

**[0014]** At least one of the vaporization substances could be a wax.

**[0015]** The vaporization substances could also or instead include a gel.

5 **[0016]** Some embodiments also include regulators to control movement of the vaporization substances to the mixer. The regulators could include, for example, any one or more of: a regulator that includes a wick, a regulator that includes a valve, a regulator that includes a pump, and a regulator comprising a mechanical feed structure. An example of a mechanical feed structure is a screw conveyor.

10 **[0017]** The regulators could provide dosage control for the apparatus.

**[0018]** An apparatus could also include a power controller to control power to the atomizer.

**[0019]** In some embodiments, the mixer includes a mixing channel to receive the vaporization substances.

15 **[0020]** The mixer could also or instead include a stirring element. Such a stirring element could be or include a stirring element that is driven by an electric motor, a magnetic stirring element, or an acoustic stirring element.

**[0021]** Another aspect of the present disclosure relates to an apparatus that includes a mixer to receive vaporization substances and an atomizer, in fluid communication with the  
20 mixer, to vaporize a vaporization substance mixture. The mixer includes multiple mixing elements to mix the vaporization substances and form the vaporization substance mixture.

**[0022]** Embodiments disclosed above and/or elsewhere herein could also or instead be implemented in conjunction with an apparatus that includes a multiple-element mixer. For example, such an apparatus could also include chambers to store respective vaporization

substances. The chambers could include a chamber with an engagement structure to engage with a complementary engagement structure of the apparatus.

[0023] A channel in fluid communication with the atomizer could also be provided in such an apparatus, and in an embodiment, an apparatus also includes a mouthpiece in fluid communication with the channel.

[0024] Some embodiments also include regulators to control movement of the vaporization substances to the mixer. The regulators could provide dosage control for the apparatus. The regulators could include, for example, any one or more of: a regulator that includes a wick, a regulator that includes a valve, a regulator that includes a pump, and a regulator comprising a mechanical feed structure. An example of a mechanical feed structure is a screw conveyor.

[0025] An apparatus could also include a power controller to control power to the atomizer.

[0026] In some embodiments, the mixer includes a mixing channel to receive the vaporization substances.

[0027] The mixing elements of the mixer could include, for example, a splitter to split a stream that includes the vaporization substances into multiple streams, and a combiner coupled to the splitter to combine the multiple streams.

[0028] In some embodiments, the mixing elements are or include wells.

[0029] The mixing elements could also or instead include ridges.

[0030] In another embodiment, the mixing elements include grooves.

[0031] The mixing elements could include linear elements and/or helical elements.

[0032] Methods are also contemplated. For example, according to another aspect of the present disclosure, a method involves providing a mixer to receive and actively mix a plurality of vaporization substances to form a vaporization substance mixture; and providing an

atomizer to vaporize the vaporization substance mixture. Such a method could also involve arranging the atomizer in fluid communication with the mixer.

**[0033]** In some embodiments, a method includes providing chambers to store respective vaporization substances of the plurality of vaporization substances, and could also involve  
5 arranging the chambers in fluid communication with the mixer.

**[0034]** Other components could also or instead be provided. For example, a method could involve providing a channel for fluid communication with the atomizer, and in some embodiments providing a mouthpiece for fluid communication with the channel.

**[0035]** The vaporization substances could also be provided, and could include any one or  
10 more of: a liquid, a dry substance, a wax, and a gel.

**[0036]** A method could involve providing regulators to control movement of the vaporization substances to the mixer, and in some embodiments arranging the regulators in fluid communication with the mixer. The regulators could include any one or more of: a regulator comprising a wick, a regulator comprising a valve, a regulator comprising a pump,  
15 and a regulator comprising a mechanical feed structure.

**[0037]** In some embodiments, a method involves providing a power controller to control power to the atomizer. A method could also involve coupling the power controller to the atomizer.

**[0038]** Regarding the mixer, the mixer could include a mixing channel to receive the  
20 vaporization substances. The mixer could also or instead include a stirring element. Examples of a stirring element include any one or more of: a stirring element to be driven by an electric motor, a magnetic stirring element, and an acoustic stirring element.

**[0039]** Another method involves providing a mixer to receive and mix a plurality of vaporization substances, with the mixer comprising a plurality of mixing elements to mix the  
25 vaporization substances and form a vaporization substance mixture; and providing an atomizer to vaporize the vaporization substance mixture.

[0040] Such a method could include features disclosed above and/or elsewhere herein. For example, a method relating to a multiple-element mixer could also involve arranging the atomizer in fluid communication with the mixer.

[0041] In some embodiments, a method relating to a multiple-element mixer includes providing chambers to store respective vaporization substances of the plurality of vaporization substances, and could also involve arranging the chambers in fluid communication with the mixer.

[0042] A method relating to a multiple-element mixer could involve providing a channel for fluid communication with the atomizer, and in some embodiments providing a mouthpiece for fluid communication with the channel.

[0043] The vaporization substances could also be provided, and as described herein could include any one or more of: a liquid, a dry substance, a wax, and a gel.

[0044] A method relating to a multiple-element mixer could involve providing regulators to control movement of the vaporization substances to the mixer, and in some embodiments arranging the regulators in fluid communication with the mixer. The regulators could include any one or more of: a regulator comprising a wick, a regulator comprising a valve, a regulator comprising a pump, and a regulator comprising a mechanical feed structure.

[0045] In some embodiments, a method relating to a multiple-element mixer involves providing a power controller to control power to the atomizer. A method relating to a multiple-element mixer could also involve coupling the power controller to the atomizer.

[0046] A multiple-element mixer could include a mixing channel to receive the vaporization substances.

[0047] The mixing elements could include, for example, any of: a splitter to split a stream that includes the vaporization substances into a plurality of streams and a combiner coupled to the splitter to combine the plurality of streams, wells, ridges, grooves, linear elements, and helical elements.

[0048] Another aspect of the present disclosure relates to a method of use of an apparatus as disclosed herein. Such a method could involve initiating supply of a plurality of vaporization substances to the mixer; initiating vaporization of the vaporization substance mixture by the atomizer to produce vapor; and inhaling the vapor.

5 [0049] According to a further aspect of the present disclosure, a method involves initiating supply of a plurality of vaporization substances to a mixer for active mixing of the vaporization substances to form a vaporization substance mixture; initiating vaporization of the vaporization substance mixture by an atomizer to produce vapor; and inhaling the vapor.

10 [0050] A similar method relating to a different type of mixer could involve initiating supply of a plurality of vaporization substances to a mixer that comprises a plurality of mixing elements to mix the vaporization substances and form a vaporization substance mixture; initiating vaporization of the vaporization substance mixture by an atomizer to produce vapor; and inhaling the vapor.

15 [0051] Other aspects and features of embodiments of the present disclosure will become apparent to those ordinarily skilled in the art upon review of the following description.

### **BRIEF DESCRIPTION OF THE DRAWINGS**

[0052] For a more complete understanding of the present disclosure, reference is now made to the following description taken in conjunction with the accompanying drawings, in which:

20 [0053] Fig. 1 is a plan view of an example vaporization device;

[0054] Fig. 2 is an isometric view of the vaporization device in Fig. 1;

[0055] Fig. 3 is an isometric and partially exploded view of an example multi-chamber vaporization device;

25 [0056] Fig. 4 is a cross-sectional view of the example multi-chamber vaporization device of Fig. 3, along line A--A in Fig. 3;

[0057] Fig. 5 is a block diagram of an example vaporization device that enables mixing of multiple vaporization substances prior to vaporization;

[0058] Fig. 6A is a block diagram of an example stirring element according to an embodiment;

5 [0059] Fig. 6B is a block diagram of an example stirring element according to another embodiment;

[0060] Fig. 7A is a cross-sectional view of a passive mixing channel according to an embodiment;

10 [0061] Fig. 7B is a cross-sectional view of a passive mixing channel according to another embodiment;

[0062] Fig. 7C is a cross-sectional view of a passive mixing channel according to yet another embodiment;

[0063] Fig. 7D is a cross-sectional view of a passive mixing channel according to a further embodiment;

15 [0064] Fig. 8 is an isometric view of a multi-chamber cartridge according to an embodiment;

[0065] Fig. 9 is an isometric and partially exploded view of the multi-chamber cartridge of Fig. 8;

[0066] Fig. 10 is a plan view of the multi-chamber cartridge of Fig. 8;

20 [0067] Fig. 11 is a top view of the multi-chamber cartridge of Fig. 8;

[0068] Fig. 12 is a cross-sectional view of the example multi-chamber cartridge of Fig. 8, along line B--B in Fig. 11;

[0069] Fig. 13 is a cross-sectional and partially exploded view of an example of engagement structures in the multi-chamber cartridge of Fig. 8, along a part of line B--B in Fig. 11;

[0070] Fig. 14 is a flow diagram illustrating a method according to an embodiment;

5 [0071] Fig. 15 is a flow diagram illustrating a method according to another embodiment.

### **DETAILED DESCRIPTION**

[0072] For illustrative purposes, specific example embodiments will be explained in greater detail below in conjunction with the figures. It should be appreciated, however, that the present disclosure provides many applicable concepts that can be embodied in any of a  
10 wide variety of specific contexts. The specific embodiments discussed are merely illustrative and do not limit the scope of the present disclosure. For example, embodiments could include additional, different, or fewer features than shown in the drawings. The figures are also not necessarily drawn to scale.

[0073] The present disclosure relates, in part, to vaporization devices for vaporization  
15 substances that include active ingredients or substances such as one or more cannabinoids or nicotine. However, the vaporization devices described herein could also or instead be used for vaporization substances without an active ingredient or substance. As used herein, the term “cannabinoid” is generally understood to include any chemical compound that acts upon a cannabinoid receptor. Cannabinoids could include endocannabinoids (produced naturally by  
20 humans and animals), phytocannabinoids (found in cannabis and some other plants), and synthetic cannabinoids (manufactured artificially).

[0074] Examples of phytocannabinoids include, but are not limited to, cannabigerolic acid (CBGA), cannabigerol (CBG), cannabigerol monomethylether (CBGM), cannabigerovarin (CBGV), cannabichromene (CBC), cannabichromevarin (CBCV), cannabidiol (CBD),  
25 cannabidiol monomethylether (CBDM), cannabidiol-C4 (CBD-C4), cannabidivarin (CBDV), cannabidiolcol (CBD-C1), delta-9-tetrahydrocannabinol ( $\Delta^9$ -THC), delta-9-tetrahydrocannabinolic acid A (THCA-A), delta-9-tetrahydrocannabinolic acid B (THCA-B),

delta-9-tetrahydrocannabinolic acid-C4 (THCA-C4), delta-9-tetrahydrocannabinol-C4, delta-9-tetrahydrocannabivarin (THCV), delta-9-tetrahydrocannabinol (THC), delta-7-cis-iso tetrahydrocannabivarin, delta-8-tetrahydrocannabinol ( $\Delta$ 8-THC), cannabicyclol (CBL), cannabicyclovarin (CBLV), cannabielsoin (CBE), cannabinol (CBN), cannabinol methylether (CBNM), cannabinol-C4 (CBN-C4), cannabivarin (CBV), cannabinol-C2 (CBN-C2), 5 cannabiorcol (CBN-C1), cannabiodiol (CBND), cannabiodivarin (CBVD), cannabitol (CBT), 10-ethoxy-9hydroxy-delta-6a-tetrahydrocannabinol, 8,9-dihydroxy-delta-6a-tetrahydrocannabinol, cannabitolvarin (CBTV), ethoxy-cannabitolvarin (CBTVE), dehydrocannabifuran (DCBF), cannabifuran (CBF), cannabichromanon (CBCN), 10 cannabicitran (CBT), 10-oxo-delta-6a-tetrahydrocannabinol (OTHC), delta-9-cis-tetrahydrocannabinol (cis-THC), 3,4,5,6-tetrahydro-7-hydroxy-alpha-alpha-2-trimethyl-9-n-propyl-2, 6-methano-2H-1-benzoxocin-5-methanol (OH-iso-HHCV), cannabiripsol (CBR), trihydroxy-delta-9-tetrahydrocannabinol (triOH-THC), cannabinol propyl variant (CBNV), and derivatives thereof.

15 **[0075]** Examples of synthetic cannabinoids include, but are not limited to, naphthoylindoles, naphthylmethylindoles, naphthoylpyrroles, naphthylmethylindenes, phenylacetylindoles, cyclohexylphenols, tetramethylcyclopropylindoles, adamantoylindoles, indazole carboxamides, and quinolinyl esters.

20 **[0076]** A cannabinoid may be in an acid form or a non-acid form, the latter also being referred to as the decarboxylated form since the non-acid form can be generated by decarboxylating the acid form. Within the context of the present disclosure, where reference is made to a particular cannabinoid, the cannabinoid can be in its acid or non-acid form, or be a mixture of both acid and non-acid forms.

25 **[0077]** A vaporization substance may comprise a cannabinoid in its pure or isolated form or a source material comprising the cannabinoid. Examples of source materials comprising cannabinoids include, but are not limited to, cannabis or hemp plant material (e.g, flowers, seeds, trichomes, and kief), milled cannabis or hemp plant material, extracts obtained from cannabis or hemp plant material (e.g., resins, waxes and concentrates), and distilled extracts or kief. In some embodiments, pure or isolated cannabinoids and/or source materials comprising

cannabinoids may be combined with water, lipids, hydrocarbons (e.g., butane), ethanol, acetone, isopropanol, or mixtures thereof.

**[0078]** In some embodiments, the cannabinoid is tetrahydrocannabinol (THC). THC is only psychoactive in its decarboxylated state. The carboxylic acid form (THCA) is non-psychoactive. Delta-9-tetrahydrocannabinol ( $\Delta^9$ -THC) and delta-8-tetrahydrocannabinol ( $\Delta^8$ -THC) produce the effects associated with cannabis by binding to the CB1 cannabinoid receptors in the brain.

**[0079]** In some embodiments, the cannabinoid is cannabidiol (CBD). The terms "cannabidiol" or "CBD" are generally understood to refer to one or more of the following compounds, and, unless a particular other stereoisomer or stereoisomers are specified, includes the compound " $\Delta^2$ -cannabidiol." These compounds are: (1)  $\Delta^5$ -cannabidiol (2-(6-isopropenyl-3-methyl-5-cyclohexen-1-yl)-5-pentyl-1,3-benzenediol); (2)  $\Delta^4$ -cannabidiol (2-(6-isopropenyl-3-methyl-4-cyclohexen-1-yl)-5-pentyl-1,3-benzenediol); (3)  $\Delta^3$ -cannabidiol (2-(6-isopropenyl-3-methyl-3-cyclohexen-1-yl)-5-pentyl-1,3-benzenediol); (4)  $\Delta^{3,7}$ -cannabidiol (2-(6-isopropenyl-3-methylenecyclohex-1-yl)-5-pentyl-1,3-benzenediol); (5)  $\Delta^2$ -cannabidiol (2-(6-isopropenyl-3-methyl-2-cyclohexen-1-yl)-5-pentyl-1,3-benzenediol); (6)  $\Delta^1$ -cannabidiol (2-(6-isopropenyl-3-methyl-1-cyclohexen-1-yl)-5-pentyl-1,3-benzenediol); and (7)  $\Delta^6$ -cannabidiol (2-(6-isopropenyl-3-methyl-6-cyclohexen-1-yl)-5-pentyl-1,3-benzenediol).

**[0080]** In some embodiments, the cannabinoid is a mixture of tetrahydrocannabinol (THC) and cannabidiol (CBD). The w/w ratio of THC to CBD in the vaporization substance may be about 1:1000, about 1:900, about 1:800, about 1:700, about 1:600, about 1:500, about 1:400, about 1:300, about 1:250, about 1:200, about 1:150, about 1:100, about 1:90, about 1:80, about 1:70, about 1:60, about 1:50, about 1:45, about 1:40, about 1:35, about 1:30, about 1:29, about 1:28, about 1:27, about 1:26, about 1:25, about 1:24, about 1:23, about 1:22, about 1:21, about 1:20, about 1:19, about 1:18, about 1:17, about 1:16, about 1:15, about 1:14, about 1:13, about 1:12, about 1:11, about 1:10, about 1:9, about 1:8, about 1:7, about 1:6, about 1:5, about 1:4.5, about 1:4, about 1:3.5, about 1:3, about 1:2.9, about 1:2.8, about 1:2.7, about 1:2.6, about 1:2.5, about 1:2.4, about 1:2.3, about 1:2.2, about 1:2.1, about 1:2, about 1:1.9, about 1:1.8, about 1:1.7, about 1:1.6, about 1:1.5, about 1:1.4, about 1:1.3, about 1:1.2, about

1:1.1, about 1:1, about 1.1:1, about 1.2:1, about 1.3:1, about 1.4:1, about 1.5:1, about 1.6:1, about 1.7:1, about 1.8:1, about 1.9:1, about 2:1, about 2.1:1, about 2.2:1, about 2.3:1, about 2.4:1, about 2.5:1, about 2.6:1, about 2.7:1, about 2.8:1, about 2.9:1, about 3:1, about 3.5:1, about 4:1, about 4.5:1, about 5:1, about 6:1, about 7:1, about 8:1, about 9:1, about 10:1, about  
5 11:1, about 12:1, about 13:1, about 14:1, about 15:1, about 16:1, about 17:1, about 18:1, about 19:1, about 20:1, about 21:1, about 22:1, about 23:1, about 24:1, about 25:1, about 26:1, about 27:1, about 28:1, about 29:1, about 30:1, about 35:1, about 40:1, about 45:1, about 50:1, about 60:1, about 70:1, about 80:1, about 90:1, about 100:1, about 150:1, about 200:1, about 250:1, about 300:1, about 400:1, about 500:1, about 600:1, about 700:1, about 800:1, about 900:1, or  
10 about 1000:1.

**[0081]** In some embodiments, a vaporization substance may include products of cannabinoid metabolism, including 11-hydroxy- $\Delta^9$ -tetrahydrocannabinol (11-OH-THC).

**[0082]** These particulars of cannabinoids are intended solely for illustrative purposes. Other embodiments are also contemplated.

15 **[0083]** Fig. 1 is a plan view of an example vaporization device 100. In Fig. 1, the vaporization device 100 is viewed from the side. The vaporization device 100 could also be referred to as a vaporizer, a vaporizer pen, a vape pen or an electronic or “e-” cigarette, for example. The vaporizer 100 includes a cap 102, a chamber 104, a base 106 and a battery compartment 108.

20 **[0084]** The cap 102 is an example of a lid or cover, and includes a tip 112 and sidewalls 114 and 115, which could be sides or parts of the same cylindrical sidewall in some embodiments. The cap 102, in addition to sealing an end of an interior space of the chamber 104, could also provide a mouthpiece through which a user can draw vapor from the vaporization device 100. The mouthpiece could be tapered, as shown, or otherwise shaped for  
25 a user’s comfort. The present disclosure is not limited to any particular shape of the cap 102.

[0085] The cap 102 could be made from one or more materials including metals, plastics, elastomers and ceramics, for example. However, other materials could also or instead be used.

[0086] In other embodiments, the mouthpiece could be separate from the cap. For  
5 example, the cap could be connected to the mouthpiece by a hose or pipe. The hose or pipe could accommodate the flow of vapor from the cap to the mouthpiece. The hose or pipe could also be flexible, allowing a user to orient the mouthpiece independently from the cap.

[0087] The chamber 104 is an example of a vessel to store a vaporization substance prior to vaporization. Although embodiments are described herein primarily in the context of  
10 vaporization liquids such as oil concentrates, in general a chamber may store other forms of vaporization substances, including waxes and gels, for example. Vaporization substances with water-based carriers are also contemplated. A vaporization device could be capable of vaporizing water-based carriers with emulsified cannabinoids, for example. In some  
15 embodiments, chambers could contain dry vaporization substances. The chamber 104 could also be referred to as a container, a housing or a tank.

[0088] The chamber 104 includes outer walls 118 and 120. The outer walls 118 and 120 of the chamber 104 could be made from one or more transparent or translucent materials, such as tempered glass or plastics, in order to enable a user to visibly determine the quantity of  
20 vaporization substance in the chamber. The outer walls 118 and 120 could instead be made from one or more opaque materials such as metal alloys, plastics or ceramics, to protect the vaporization substance from degradation by ultraviolet radiation, for example. The outer walls 118 and 120 of the chamber 104 could include markings to aid the user in determining the quantity of vaporization liquid in the chamber. The chamber 104 could be any of a  
25 number of different heights. Although multiple outer walls are shown in Fig. 1 at 118 and 120, the chamber 104 is perhaps most often cylindrical, with a single outer wall.

[0089] The chamber 104 engages the cap 102, and could be coupled to the cap, via an engagement or connection at 116. A gasket or other sealing member could be provided between the chamber 104 and the cap 102 to seal the vaporization substance in the chamber.

**[0090]** Some chambers are “non-recloseable” or “disposable” and cannot be opened after initial filling. Such chambers are permanently sealed once closed. Others are recloseable chambers in which the engagement at 116, between the cap 102 and the chamber 104, is releasable. For example, the cap 102 could be a cover that releasably engages the chamber  
5 104 and seals a vaporization substance in the chamber 104. A releasable engagement could include, for example, a threaded engagement or other type of connection, or an abutment between the chamber 104 and the cap 102, without necessarily an actual connection between the chamber and the cap. Such a releasable engagement permits the cap 102 to be disengaged or removed from the chamber 104 so that the chamber can be cleaned, emptied, and/or filled  
10 with a vaporization substance, for example. The cap 102 could then re-engage with the chamber 104 to seal the vaporization substance inside the chamber.

**[0091]** Fig. 1 also illustrates a stem 110 inside the chamber 104. The stem 110 is a hollow tube or channel through which vapor can be drawn into and through cap 102. The stem 110 may also be referred to as a central column, a central post, a chimney, a hose or a pipe. The  
15 stem 110 includes outer walls 122 and 124, although in many embodiments the stem will likely be cylindrical, with a single outer wall. Materials such as stainless steel, other metal alloys, plastics and ceramics could be used for stems such as the stem 110. The stem 110 couples the cap 102 via an engagement or connection 126. Similar to the engagement or connection 116, the engagement or connection 126 could be a releasable engagement or  
20 connection that includes a releasable engagement between the stem 110 and the cap 102. In some embodiments, the engagement 126 is in the form of, or includes, a releasable connection.

**[0092]** Although labeled separately in Fig. 1, the engagements at 116 and 126 are operationally related in some embodiments. For example, screwing the cap 102 onto the stem  
25 110 could also engage the cap with the chamber 104, or similarly screwing the cap onto the chamber could also engage the cap with the stem.

**[0093]** An atomizer 130 is provided at the base of the stem 110 inside the chamber 104. The atomizer 130 may also be referred to as a heating element, a core, or a ceramic core. The atomizer 130 includes sidewalls 131 and 133, which could actually be a single cylindrical or

frustoconical wall in some embodiments, and one or more wicking holes or intake holes, one of which is shown at 134. The sidewalls of the atomizer 130 could be made from a metal alloy such as stainless steel, for example. The sidewalls 131 and 133 of the atomizer 130 could be made from the same material as the stem 110, or from different materials.

5 [0094] The atomizer 130 engages, and could couple with, the stem 110 via an engagement 132, and with the base 106 via an engagement 136. Although the engagements 132 and 136 could be releasable, the stem 110, the atomizer 130, and the base 106 could be permanently attached together. The atomizer sidewalls 131 and 133 could even be formed with the stem 110 as an integrated single physical component.

10 [0095] In general, the atomizer 130 converts the vaporization substance in the chamber 104 into a vapor, which a user draws from the vaporization device 100 through the stem 110 and the cap 102. Vaporization liquid, for example, could be drawn into the atomizer 130 through the wicking hole 134 and a wick. The atomizer 130 could include a heating element, such as a resistance coil around a ceramic wick, to perform the conversion of vaporization  
15 liquid into vapor. A ceramic atomizer could have an integrated heating element such as a coiled wire inside the ceramic, similar to rebar in concrete, in addition to or instead of being wrapped in a coiled wire.

[0096] In some embodiments, the combination of the atomizer 130 and the chamber 104 is referred to as a cartomizer.

20 [0097] The base 106 supplies power to the atomizer 130, and may also be referred to as an atomizer base. The base 106 includes sidewalls 138 and 139, which could be a single sidewall such as a cylindrical sidewall. The base 106 engages, and could also be coupled to the chamber 104 via an engagement 128. The engagement 128 could be a fixed connection. However, in some embodiments, the engagement 128 is a releasable engagement, and the  
25 base 106 could be considered a form of a cover that releasably engages the chamber 104 and seals a vaporization substance in the chamber 104. In such embodiments, the engagement 128 could include a threaded engagement, a threaded connection, or an abutment between the chamber 104 and the base 106, for example. A gasket or other sealing member could be

provided between the chamber 104 and the base 106 to seal the vaporization substance in the chamber. Such a releasable engagement enables removal or disengagement of the base 106 from the chamber 104 to permit access to the interior of the chamber, so that the chamber can be emptied, cleaned, and/or filled with a vaporization substance, for example. The base 106  
5 could then re-engage with the chamber 104 to seal the vaporization substance inside the chamber.

**[0098]** The base 106 generally includes circuitry to supply power to the atomizer 130. For example, the base 106 could include electrical contacts that connect to corresponding electrical contacts in the battery compartment 108. The base 106 could further include  
10 electrical contacts that connect to corresponding electrical contacts in the atomizer 130. The base 106 could reduce, regulate or otherwise control the power/voltage/current output from the battery compartment 108. However, this functionality could also or instead be provided by the battery compartment 108 itself. The base 106 could be made from one or more materials including metals, plastics, elastomers and ceramics, for example, to carry or  
15 otherwise support other base components such as contacts and/or circuitry. However, other materials could also or instead be used.

**[0099]** The combination of a cap 102, a chamber 104, a stem 110, an atomizer 130, and a base 106 is often referred to as a cartridge or “cart”.

**[00100]** The battery compartment 108 could also be referred to as a battery housing. The  
20 battery compartment 108 includes sidewalls 140 and 141, a bottom 142 and a button 144. The sidewalls 140 and 141, as noted above for other sidewalls, could be a single wall such as a cylindrical sidewall. The battery compartment 108 engages, and could also couple to, the base 106 via an engagement 146. The engagement 146 could be a releasable engagement such as a threaded connection or a magnetic connection, to provide access to the inside of the  
25 battery compartment 108. The battery compartment 108 could include single-use batteries or rechargeable batteries such as lithium-ion batteries. A releasable engagement 146 enables replacement of single-use batteries and/or removal of rechargeable batteries for charging, for example. In some embodiments, rechargeable batteries could be recharged by an internal battery charger in the battery compartment 108 without removing them from the vaporization

device 100. A charging port (not shown) could be provided in the bottom 142 or a sidewall 140, 141, for example. The battery compartment 108 could be made from the same material(s) as the base 106 or from one or more different materials.

**[00101]** The button 144 is one example of a user input device, which could be implemented in any of various ways. Examples include a physical or mechanical button or switch such as a push button. A touch sensitive element such as a capacitive touch sensor could also or instead be used. A user input device need not necessarily require movement of a physical or mechanical element.

**[00102]** Although shown in Fig. 1 as a closed or flush engagement, the engagement 146 between the base 106 and the battery compartment 108 need not necessarily be entirely closed. A gap between outer walls of the base 106 and the battery compartment 108 at the engagement 146, for example, could provide an air intake path to one or more air holes or apertures in the base that are in fluid communication with the interior of the stem 110. An air intake path could also or instead be provided in other ways, such as through one or more apertures in a sidewall 138, 139, elsewhere in the base 106, and/or in the battery compartment 108. When a user draws on a mouthpiece, air could be pulled through the air intake path into the stem 110, to mix with vapor formed by the atomizer 130.

**[00103]** The battery compartment 108 powers the vaporization device 100 and allows powered components of the vaporization device, including at least the atomizer 130, to operate. Other powered components could include, for example, one or more light-emitting diodes (LEDs), speakers and/or other indicators of device power status (on / off), device usage status (on when a user is drawing vapor), etc. In some embodiments, speakers and/or other audible indicators could produce long, short, or intermittent “beep” sounds as a form of indicator of different conditions. Haptic feedback could also or instead be used to provide status or condition indicators. Varying vibrations and/or pulses, for example, could indicate different statuses or actions in a vaporization device, such as on/off, currently vaporizing, power source connected, etc. Haptic feedback could be provided using small electric motors as in devices such as mobile phones, other electrical and/or mechanical means, or even magnetic means such as one or more controlled electronic magnets.

**[00104]** As noted above, in some embodiments, the cap 102, the chamber 104, the stem 110, the atomizer 130, the base 106 and/or the battery compartment 108 are cylindrical in shape or otherwise shaped in a way such that sidewalls that are separately labeled in Fig. 1 could be formed by a single sidewall. In these embodiments, the sidewalls 114 and 115  
5 represent sides of the same sidewall. Similar comments apply to outer walls 118 and 120, sidewalls 131 and 133, outer walls 122 and 124, sidewalls 138 and 139, sidewalls 140 and 141, and other walls that are shown in other drawings and/or described herein. However, in general, caps, chambers, stems, atomizers, bases and/or battery compartments that are not cylindrical in shape are also contemplated. For example, these components could be  
10 rectangular, triangular, or otherwise shaped.

**[00105]** Fig. 2 is an isometric view of the vaporization device 100. In Fig. 2, the cap 102, the chamber 104, the stem 110, the atomizer 130, the base 106, and the battery compartment 108 are illustrated as being cylindrical in shape. However, as noted above, this is not necessarily the case in other vaporization devices. Fig. 2 also illustrates a hole 150 through  
15 the tip 112 in the cap 102. The hole 150 could be coupled to the stem 110 through a channel in the cap 102. The hole 150 allows a user to draw vapor through the cap 102. In some embodiments, a user operates the button 144 to vaporize a vaporization substance. Other vaporization devices could be automatically activated to supply power from the battery compartment 108 to powered components of the vaporization device when a user inhales  
20 through the hole 150. In such embodiments, a button 144 need not be operated to use a vaporization device, and need not necessarily even be provided.

**[00106]** Fig. 3 is an isometric and partially exploded view of an example multi-chamber vaporization device, and Fig. 4 is a cross-sectional view of the example multi-chamber vaporization device along line A--A in Fig. 3. The vaporization device 300 has a multi-part  
25 body, with a main body 302 and a removable cover 304. The main body 302 and the cover 304 could be made from the same material(s) or different materials, including one or more of metals, plastics, elastomers and ceramics, for example. However, other materials could also or instead be used.

[00107] The main body 302 and the cover 304 include compartments to receive vaporization substance chambers 312 and a channel 310. The compartments in the main body 302 are shown at 311, 313 in Fig. 4, and the cover 304 also includes such compartments. The cover 304 tapers at 306 to a mouthpiece 308 in the example shown, and the mouthpiece is in fluid communication with the channel 310. The main body 302 could at least partially carry or otherwise support components such as the channel 310 and the chambers 312 as shown, and other components such as one or more batteries, electrical contacts, and/or circuitry. Similarly, the cover 304 could at least partially carry or otherwise support components such as the channel 310 and the chambers 312, as well as the mouthpiece 308.

[00108] Various channels such as the channel 310 enable fluid flow through a vaporization apparatus such as a vaporization device, or at least parts thereof. Such fluid may include air, at an intake side of an atomizer for example, or a mixture of air and vapor upstream of an atomizer when the atomizer is operating to vaporize a vaporization substance. Fluid flow channels may also be referred to as air channels, but are referenced herein primarily as channels.

[00109] The mouthpiece 308 could be made from the same material(s) as the remainder of the cover 304, and could even be integrated with the cover. In the embodiment shown, the mouthpiece 308 engages with the remainder of the cover 304 at an engagement or connection 309. This engagement or connection 309 could be fixed, which might be preferable in embodiments in which the mouthpiece 308 is cylindrical as shown. In other embodiments, a rotatable or otherwise movable engagement or connection 309 might be preferred, so that a user can position the mouthpiece 308 in any preferred orientation relative to the main body 302 and/or the remainder of the cover 304.

[00110] Materials such as stainless steel, other metal alloys, plastics and ceramics could be used for the channel 310.

[00111] The chambers 312 could be made, at least in part, from one or more materials such as tempered glass, plastics, metal alloys, and/or ceramics. The chambers 312 could be

substantially similar to chamber 104 shown by way of example in Figs. 1 and 2, and could be coupled to other parts that are made from different materials.

**[00112]** The cover 304 is removable or releasable from the main body 302. In the example shown in Fig. 3, a tab 314 on the cover 304 could be provided with a protrusion on its inner surface, to engage with a groove or slot 316 in the main body 302 when the vaporization device 300 is assembled or closed. This is an example of a releasable engagement between the main body 302 and the cover 304. The cover 304 could be removed, to install or remove chambers 312 and/or for cleaning the device 300 for example, by pulling the cover 304 away from the main body 302 with sufficient force to release the protrusion on the tab 314 from the slot or groove 316. Removal of the cover 304 in the embodiment shown could also or instead involve prying the tab 314 away from the slot or groove 316 to release the tab protrusion and allow the cover to be removed.

**[00113]** The main body 302 could include a structure 318 to accommodate the tab 314, so that the outer surface of the tab is flush with the outer surface of the main body when the device 300 is assembled. The structure 318 could be larger than the tab 314 in some embodiments, to provide clearance for a user to insert a fingernail or tool to pry the tab away from the slot or groove 316 when the cover 304 is to be removed.

**[00114]** In operation, one or more batteries inside the main body 302 provide power to one or more atomizers, which vaporize a mixture of vaporization substances from multiple chambers 312. Any of various arrangements or implementations are possible, and examples are disclosed herein.

**[00115]** It should be appreciated, however, that the example device 300 is solely for the purpose of illustration. Other embodiments are also contemplated. For example, the channel 310 need not be a separate component, and could be integrated or integral with the main body 302 and/or the cover 304. The channel 310 and/or the chambers 312 could be accommodated entirely within the main body 302, in which case the cover 304 need not include compartments to receive part of each chamber. Compartments could be implemented in any of various ways, and not only as the bores shown at 311, 313 in Fig. 4. Multiple engagement

structures such as the tab 314 and the slot or groove 316 could be provided. Other types of connection or engagement between a main body and a cover, such as a magnetic connection, are also possible. Different shapes or layouts could be implemented, to have a central channel with compartments or structures to accommodate chambers around the central channel, for example. A multi-chamber vaporization device with a hexagonal cross-sectional shape, for example, could accommodate six cartridges or chambers around a central air channel or mixing channel. At least certain shapes could be suitable for other types of releasable engagement between a main body and a cover, such as a threaded engagement for a cylindrical vaporization device.

10 **[00116]** With multiple vaporization substances available in a multi-chamber vaporization device, more than one vaporization substance could be vaporized for inhalation. For example, as disclosed herein, multiple vaporization substances could be mixed to form a vaporization substance mixture, with that mixture then being vaporized by an atomizer. Fig. 5 is a block diagram of an example vaporization device that enables mixing of multiple vaporization  
15 substances prior to vaporization.

**[00117]** The example device 500 includes multiple chambers 510, 512, 514, 516, 518 to store respective vaporization substances. Examples of vaporization substances and how vaporization substance chambers could be implemented are disclosed elsewhere herein. Vaporization substances could have any of various effects. For example, some vaporization  
20 substances could include one or more active ingredients that have a psychoactive effect, whereas others could include flavorants such as terpenes. Some vaporization substances could include an antidote for an active ingredient or substance in another vaporization substance. CBD is one example of an antidote to an active ingredient or substance in the form of THC. Other antidotes and active ingredients or substances are also possible. In general, an  
25 antidote as referenced herein is intended to encompass a substance that may reduce, reverse, or otherwise counteract one or more effects of an active ingredient or substance. An antidote could also or instead include, for example, a substance that could interfere with a cannabinoid receptor such as the CB1 receptors and/or CB2 receptors.

[00118] Valves 520, 522, 524, 526, 528 in the device 500 are examples of regulators in fluid communication with respective chambers 510, 512, 514, 516, 518, through channels 511, 513, 515, 517, 519, to control movement of the vaporization substances from the respective chambers to a mixer 536. The mixer 536 is in fluid communication with the valves 520, 522, 524, 526, 528 through channels 521, 523, 525, 527, 529 in the embodiment shown. Other forms of regulator include, for example, wicks, pumps, and mechanical feed structures such as screw conveyors. A vaporization device could include regulators of different types. Not all types of regulator are necessarily separately controlled. A wick, for example, draws a vaporization substance from a chamber to an atomizer for vaporization, but the wick itself is not controlled.

[00119] Regardless of the type(s) of regulators in a multi-chamber device, the regulators may be useful in providing a measure of dosage control. Different vaporization substances could have different levels of active ingredients, and overall dosage of active ingredients in a mixture of vaporization substances could be controlled by controlling the regulators.

[00120] Any or all of the valves 520, 522, 524, 526, 528 in the device 500 could be controlled, for example, by one or more user input devices 534. The user input devices 534 could include switches, sliders, dials, and/or other types of input device that enable a user to control vaporization substance flow from each chamber 510, 512, 514, 516, 518. Other input device examples are disclosed elsewhere herein, with reference to the button 144 in Figs. 1 and 2, for instance.

[00121] A user input device 534 need not necessarily be specific to one chamber 510, 512, 514, 516, 518. A single user input device 534 could be used to control vaporization substance flow from multiple chambers 510, 512, 514, 516, 518. Flow from all chambers could be turned on or off with one user input device 534, for example. A user input device 534 could allow a user to scroll through or otherwise select one of a number of different mixing ratios and control vaporization substance flow from multiple chambers 510, 512, 514, 516, 518 according to the selected mixing ratio. In general, one or more user input devices 534 enable a user to control the flow of vaporization substances from their respective chambers 510, 512, 514, 516, 518 to the mixer 536.

**[00122]** Control of flow of different vaporization substances from their respective chambers, by controlling regulators such as the valves 520, 522, 524, 526, 528, may also or instead take other factors into account. A desired mix or mixing ratio of vaporization substances is one example of a vaporization substance flow control parameter. Viscosity of vaporization substances is another example. Consider a vaporization device with a ceramic core atomizer at 538 and two vaporization substances in the chambers 510, 512, with a first vaporization substance in the chamber 510 having a higher viscosity than a second vaporization substance in the chamber 512. Due to its lower viscosity, the second vaporization substance may flow from its chamber 512 to the mixer 536 more rapidly than the first vaporization substance flows from its chamber 510. Regulators may be controlled based on the different viscosities and/or expected flow rates in order to achieve a desired or target mixing ratio. For a mixture that is to include equal parts by volume of the two vaporization substances in this example, regulators may be controlled to equalize vaporization substance flow rates, by controlling the valves 520, 522 to open the valve 522 to a lesser degree than the valve 520. Vaporization substance viscosity is just an example. Other flow control parameters may also or instead be used in other embodiments.

**[00123]** Control of vaporization substance flow regulators could be indirect as shown in Fig. 5, in the sense that the user input device(s) 534 provide input(s) to a controller 530, and the controller controls the regulators, which are valves 520, 522, 524, 526, 528 in the example device 500. The controller 530 could be implemented, for example, using hardware, firmware, one or more components that execute software stored in one or more non-transitory memory devices (not shown), such as a solid-data memory device or a memory device that uses movable and/or even removable storage media. Microprocessors, Application Specific Integrated Circuits (ASICs), Field Programmable Gate Arrays (FPGAs), and Programmable Logic Devices (PLDs) are examples of processing devices that could be used to execute software.

**[00124]** In the illustrated embodiment, a battery 532 provides power to the controller 530, which may then control power to other components of the example device 500. The valves 520, 522, 524, 526, 528 could be controlled in this type of implementation by controlling

power to the valves. For example, each valve 520, 522, 524, 526, 528 could be normally closed when not supplied with power and opened when powered. In other embodiments, power and control are implemented separately. In any case, a controller-based implementation could be used in conjunction at least with valves 520, 522, 524, 526, 528 that are electrically controllable. Other control mechanisms are also possible.

**[00125]** In another embodiment, the valves 520, 522, 524, 526, 528 could be controlled directly by one or more user input devices 534. A user input device 534 could be mechanically coupled to a valve 520, 522, 524, 526, 528, for example, to physically move one or more valve components to increase or decrease flow of a vaporization substance to the mixer 536.

**[00126]** The mixer 536 is coupled to receive vaporization substances, through channels 521, 523, 525, 527, 529, and mix the vaporization substances to form a vaporization substance mixture. In some embodiments, the mixer 536 is a driven or “active” mixer to actively mix vaporization substances.

**[00127]** For example, the mixer 536 could include a mixing channel to receive the vaporization substances that are to be mixed. Vaporization substances that are to be mixed could flow into a mixing channel and be mixed as they flow through the mixing channel, and/or be temporarily held in a mixing channel during mixing. In the latter example, the mixing channel could itself be considered a chamber or reservoir. A manifold could couple the chambers 510, 512, 514, 516, 518 to the mixing channel, through the channels 511/521, 513/523, 515/525, 517/527, 519/529 and valves 520, 522, 524, 526, 528 in the example device 500, so that vaporization substances from any of the chambers are available for mixing by the mixer 536. Not all vaporization substances need necessarily be mixed. For example, only a subset of available vaporization substances might be mixed. In some embodiments, a vaporization device could also include one or more cartridges with their own atomizers for vaporization separately from vaporization of a vaporization substance mixture.

**[00128]** A stirring element, positioned within a mixing channel or otherwise positioned to contact and mix vaporization substances that flow through a mixing channel for example,

could be useful in improving the mixing of vaporization substances. Vaporization substances in the chambers 510, 512, 514, 516, 518 could include different types of vaporization substances, such as liquid(s), dry substance(s) such as flower(s) or powder(s), wax(es), and/or gel(s). Mixing of different vaporization substances, whether of the same type or different types such as one or more liquids and one or more waxes, could be improved by active mixing using a driven stirring element. For example, certain vaporization substances might have higher viscosity than others and present a particular challenge for mixing prior to vaporization.

**[00129]** The mixer 536 could include a stirring element that is driven electrically, a magnetic stirring element that is driven magnetically, and/or an acoustic stirring element that is driven acoustically, for example.

**[00130]** Fig. 6A is a block diagram of an example stirring element according to an embodiment. In Fig. 6A, a stirring element 602 is positioned within a mixing channel 600. Although a flow-through mixing channel 600 open at both ends is shown by way of example, a mixing channel could include a reservoir or other holding structure to temporarily store vaporization substances during mixing and/or after mixing but before vaporization.

**[00131]** The stirring element 602 includes one or more vanes, two in the example shown, coupled to a rotor shaft 604 of an electric motor 606. The electric motor 606 could be supplied with power from one or more batteries of a vaporization device. In some embodiments, a user could operate a switch or other input device to release or actively move, by one or more pumps for example, vaporization substances into the mixing channel 600 and turn on the electric motor 606 to mix the vaporization substances. Release and/or mixing of vaporization substances could instead be initiated when a user draws on a mouthpiece, operates a power button, or otherwise activates the vaporization device for generating vapor for inhalation.

**[00132]** A dual-vane structure as shown in Fig. 6A is intended solely as an illustrative example. Other embodiments could include a stirring element with more than two vanes, a different shape or form of stirring element, and/or multiple stirring elements.

[00133] Fig. 6B is a block diagram of an example stirring element according to another embodiment. The embodiment in Fig. 6A is a direct-drive embodiment in which the stirring element 602 is directly driven by the electric motor 606. In Fig. 6B, a stirring element 612 is positioned in a mixing channel 610, but is driven indirectly, in particular magnetically or acoustically, rather than through a direct-drive arrangement in which a driving element is in direct physical contact with the stirring element as shown in Fig. 6A.

[00134] The stirring element 612 could be a bar, a solid or apertured disc, or an element having another shape, and be driven magnetically or acoustically to rotate, vibrate, reciprocate, or otherwise move within the mixing channel 610.

[00135] Acoustic mixing could also or instead be implemented without the use of a mixing or stirring element. For example, an acoustic generator could be coupled to the side walls of the mixing channel 610, causing the side walls to vibrate or otherwise agitate the vaporization substances in the mixing channel.

[00136] Other types of active mixing, such as ultrasonic mixing or sonication, could also or instead be used to mix vaporization substances.

[00137] The mixer 536 is an active mixer in some embodiments. Examples of active mixers are shown in Figs. 6A and 6B, and other examples of active mixing and mixers are also disclosed herein. An active mixer, in addition to mixing vaporization substances, could also provide a form of haptic feedback, indicating that the vaporization device is in use and actively mixing vaporization substances. A user holding a vaporization device could feel when an active mixer is operating.

[00138] Other embodiments could also or instead involve “passive” mixing of vaporization substances. For passive mixing, the mixer 536 includes multiple mixing elements that are not positively or actively driven, but introduce turbulence into vaporization substance flow or otherwise mix vaporization substances to form a vaporization substance mixture.

[00139] Fig. 7A is a cross-sectional view of a passive mixing channel 700. The mixing channel 700 receives one or more vaporization substances. The vaporization substances, in

Fig. 7A and/or in other embodiments, may be pumped, gravity-fed, or otherwise supplied to the mixing channel 700. For example, suction via inhalation could contribute to flow of vaporization substances and/or a vaporization substance mixture, into or through a mixing channel or otherwise to and/or past active or passive mixing elements.

- 5 [00140] In Fig. 7A, when vaporization substances are to be mixed, multiple vaporization substances are supplied to the mixing channel 700. It should be appreciated, however, that a vaporization device that enables mixing of vaporization substances need not necessarily preclude vaporization of a single vaporization substance. A mixing channel therefore could receive one, or more than one, vaporization substance.
- 10 [00141] The mixing channel 700 includes multiple mixing elements in the form wells 702. The wells 702, which could be rectangular or cylindrical in shape, for example, are discrete structures formed in the side walls of the mixing channel 700. The wells 702 occupy only a portion of the side walls of the mixing channel 700. Although the wells 702 are illustrated with a fixed shape and spacing in the mixing channel 700, in other embodiments wells could  
15 be differently sized and/or spaced, even randomly, in a mixing channel. Moreover, the shape and size of wells in a mixing channel could vary. For example, the side walls of the wells 702 could be tapered or slanted. One or more wells may also or instead extend around an inner surface of a mixing channel, as annular grooves or wells in the case of a cylindrical mixing channel for example.
- 20 [00142] The wells 702 could increase lateral transport of the vaporization substances within the mixing channel 700 to aid in mixing. The wells 702 could also or instead produce turbulent flow to aid in mixing. In this sense, the wells 702 passively mix the vaporization substances supplied to the mixing channel 700.

- [00143] Fig. 7B is a cross-sectional view of a passive mixing channel 710, which receives  
25 one or more vaporization substances. The vaporization substances may be pumped, gravity-fed, fed by suction, or otherwise supplied to the mixing channel 710. The mixing channel 710 includes multiple ridges 712 implemented as mixing elements. The ridges 712 could be, for example, annular protrusions around the side wall of the mixing channel 710. The gaps

between the ridges 712 could be considered grooves 714. The ridges 712 and/or grooves 714 could take any of a variety of cross-sectional shapes, including rectangular and/or triangular. Although the ridges 712 and grooves 714 are illustrated with a fixed size, spacing, and shape in the mixing channel 710, the size, spacing, and/or shape of ridges and/or grooves could vary  
5 in other embodiments.

**[00144]** Similar to the wells 702, the ridges 712 and grooves 714 aid in mixing by increasing lateral transport and/or turbulence of the vaporization substances in the mixing channel 710.

**[00145]** The ridges 712 and grooves 714 are examples of linear mixing elements, in that  
10 they extend linearly along the mixing channel 710 in an axial direction in the case of a cylindrical mixing channel. Helical mixing elements are also contemplated. Fig. 7C is a cross-sectional view of a passive mixing channel 720, which includes a helical ridge 722 and a helical groove 724 in the space between turns of the helical ridge. The helical ridge 722 forms a continuous spiral within the mixing channel 720 in the example shown. A helical  
15 ridge need not necessarily be continuous and could include multiple discrete ridge segments. Similarly, the helical groove 724 is continuous in the example shown but need not necessarily be continuous. The helical ridge 722 and/or helical groove 724 could cause the vaporization substances within the mixing channel 720 to rotate and/or move laterally while they flow through the mixing channel, aiding in mixing.

**[00146]** Fig. 7D is cross-sectional view of another example passive mixing channel 730,  
20 which receives one or more vaporization substances. The vaporization substances may be pumped, gravity-fed, fed by suction, or otherwise supplied to the mixing channel 730. The mixing channel 730 includes multiple channels 732, 734, 742 and 744. The mixing channel 730 also includes mixing elements 736, 738, 746 and 748. A stream of vaporization  
25 substances received by the mixing channel 730 is split into multiple streams (two in this example) by the mixing element 736. These multiple streams flow through the channels 732 and 734. The mixing element 738 then combines the multiple streams at the end of the channels 732 and 734, into a single stream that flows into and through the channel 740. This process of splitting and combining is repeated once more in the mixing channel 730 using the

mixing elements 746 and 748 and the channels 742, 744 and 750. In this sense, the mixing elements 736 and 746, or the channels 732/734 and 742/744, could be considered splitters coupled to combiners in the form of the mixing elements 738 and 748, or the channels 740 and 750. The process of splitting and combining using the mixing elements 736, 738, 746 and 5 748 could aid in mixing of the vaporization substances. Additional splitters and/or combiners could also be implemented in mixing channel 730 to further mix the vaporization substances. Mixing with a single splitting / combining stage or structure is also possible.

**[00147]** In general, any combination of wells, ridges, grooves, splitters, and combiners could be implemented in one or more mixing channels. For example, wells could be added to 10 the channels 732, 734, 740, 742 and/or 744 of the mixing channel 730 to potentially further aid in mixing.

**[00148]** The mixer 536, whether active, passive, or both, is intended to improve mixing between vaporization substances and increase homogeneity of a vaporization substance mixture. Mixture homogeneity could impact such properties as the vaporization temperature 15 of a mixture, rate of flow of a mixture through a ceramic core, retention of vaporization substance ratios or contents in a mixture that actually reaches an atomizer for vaporization, and/or content of a vapor that is generated by vaporizing a mixture, for example, and could therefore be an important parameter when multiple vaporization substances are to be vaporized.

**[00149]** Referring back to Fig. 5, the example vaporization device 500 also includes an atomizer 538, in fluid communication with the mixer 536 through a channel 537, to vaporize the vaporization substance mixture that is formed by the mixer. A power controller to control power to the atomizer 538 could be implemented at 530 in a controller that also provides other control features, or in a separate power controller. The power controller could provide on-off 25 power control based on operation of a power button or switch at 534 or a user inhaling on the device 500 through the mouthpiece 542, for example. In some embodiments, different voltages and/or currents could be supplied to the atomizer 538 to enable the atomizer to provide different vaporization temperatures. This type of power control, which could be considered a form of vaporization temperature control, could be provided through one or more

user input devices at 534, and/or based on sensing the types of cartridges 510, 512, 514, 516, 518 currently installed in the device 500. In general, the voltage, current, and/or power supplied to the atomizer 538 could be adjusted based on the vaporization substance(s) to be vaporized. The voltage, current, and/or power supplied to the atomizer 538 could also or  
5 instead be adjusted based on a desired flow or quantity of vapor produced by the atomizer, which could be selected or otherwise controlled using one or more user input devices 534, for example.

**[00150]** A channel in fluid communication with the atomizer 538 is shown at 539, and a mouthpiece 542 is in fluid communication with the channel so that a user can inhale vapor  
10 from the atomizer. In some embodiments, a valve 540 is controllable to regulate or otherwise control the flow of vapor to the mouthpiece 542. The controller 530 could adjust the valve 540 to provide a form of dosage control, for example.

**[00151]** Fig. 5 is a block diagram of an example vaporization device, and Figs. 6A to 7D show examples of mixers. An example multi-chamber cartridge, which could be used in an  
15 embodiment to implement multiple chambers in a vaporization device of the type shown in Fig. 5, is shown in Figs. 8 to 12.

**[00152]** Fig. 8 is an isometric view of a multi-chamber cartridge, Fig. 9 is an isometric and partially exploded view of the multi-chamber cartridge of Fig. 8, Fig. 10 is a plan view of the multi-chamber cartridge of Fig. 8, Fig. 11 is a top view of the multi-chamber cartridge of Fig.  
20 8, and Fig. 12 is a cross-sectional view of the example multi-chamber cartridge of Fig. 8 along line B--B in Fig. 11. Various features referenced in the description below are shown in one or more of these drawings.

**[00153]** The example multi-chamber cartridge 800 includes two chambers 802, 804. Two chambers of equal size are shown by way of example. There could be more than two  
25 chambers. Chambers could all be of the same size, or one or more chambers could have a different size from one or more other chambers. The chambers 802, 804 are positioned on a base 806 and could be held in place by friction fit and/or some other type of releasable engagement. A cap (not shown) screwed onto threads at an upper end of a stem 812 could

both seal the chambers 802, 804 and also hold them in place on the base 806, for example. Other engagements between a cap and the chambers 802, 804 are possible, and further examples of cap / chamber engagements are provided elsewhere herein.

**[00154]** Examples of materials from which each chamber 802, 804 could be made are provided elsewhere herein. The chambers 802, 804 could include non-recloseable chambers, recloseable chambers, or both a non-recloseable chamber and a recloseable chamber. More generally, a multi-chamber cartridge or multi-chamber vaporization device could include one or more non-recloseable chambers and/or one or more recloseable chambers.

**[00155]** A stem 812 and an atomizer 814 could be implemented as described elsewhere herein, with reference to Figs. 1 and 2, for example. In Fig. 8, a mixing channel 816 is also provided, and could be implemented by extending atomizer sidewalls relative to the embodiment shown in Figs. 1 and 2 and providing intake holes or passages 818, 819 at a distal end of the atomizer sidewalls, away from an atomizer end of the mixing channel 816. This is perhaps best shown in Fig. 12, in which the internal position of the atomizer 1210 toward the top of the mixing channel 816 is shown. Parameters such as shape of a mixing channel, any of various dimensions of a mixing channel, distance of an atomizer from a mixing element or mixing channel, and/or distance of a mixing element or mixing channel from vaporization substance intake(s) could be different for different types of vaporization substance, for example. Preferred intake to mixer distance and/or mixer to atomizer distance could be shorter for higher viscosity oils or waxes than for lower viscosity vaporization substances. Mixer to atomizer distance could also or instead take into account expected viscosity of a resultant vaporization substance mixture. More generally, any of various parameters, including not only physical parameters but also or instead other parameters such as mixing element type and/or speed, could be determined or selected based on characteristics of the vaporization substances that are to be mixed and/or expected characteristics of the resultant vaporization substance mixture.

**[00156]** As also shown in Fig. 12, mixing could take place within a passage 1212 inside the mixing channel 816. A part 1214 of the passage 1212 could be perforated or otherwise include intake holes for receiving vaporization substances for mixing. In other embodiments,

there is no separate internal passage 1212 inside the mixing channel 816. Active and/or passive mixing could be provided in the mixing channel 816, or otherwise implemented with or without a mixing channel. Any of the example mixers disclosed elsewhere herein could be used to implement vaporization substance mixing in a multi-chamber cartridge.

5 [00157] The atomizer 814 engages, and could couple with, the stem 812 and the mixing channel 816 via respective engagements, and similarly the mixing channel 816 could engage, and could couple with, the base 806 via another engagement. Although any or all of these engagements could be releasable, the stem 812, the atomizer 814, the mixing channel 816, and the base 806 could be permanently attached together. The sidewalls of the atomizer 814 and  
10 the mixing channel 816 could even be formed with the stem 812 as an integrated single physical component.

[00158] The atomizer 814 converts a mixture of the vaporization substances in the chambers 802, 804 into a vapor, which a user draws through the stem 812. Vaporization substances could be drawn into or otherwise provided to the atomizer 814 through the intake  
15 holes 818, 819, and corresponding intake holes 918, 919 in the chambers 802, 804. One or more regulators could also be provided to regulate flows of one or more of the vaporization substances to the mixing channel 816 and/or to the atomizer 814.

[00159] The base 806 supplies power to the atomizer 814, and could also supply power to other components such as an active mixer. The base 806 could be implemented, for example,  
20 in a similar manner to the base 106 (Figs. 1 and 2) as described elsewhere herein. The base 806 engages, and could also be coupled to, the chambers 802, 804 via an engagement. The engagement could be a fixed connection or a releasable engagement. In some embodiments, the base 806 could be a form of a cover that releasably engages the chambers 802, 804 and seals one or both of the chambers 802, 804. As shown in Fig. 12, the chambers 802, 804 have  
25 respective bottom walls, but in other embodiments the base 806 seals the base end of one or more chambers.

[00160] The bottom wall of each chamber 802, 804 includes an engagement structure 916, 917 to engage with a complementary engagement structure 820, 822 on the base 806. In the

example shown, the base 806 includes an engagement structure 820, 822 at each chamber position, and therefore only chambers 802, 804 with a complementary engagement structure 916, 917 to accommodate the base engagement structure can be used with the base 806. In other embodiments, only some but not all chambers and chamber positions on a base include an engagement structure. Other shapes, sizes, types, and locations of engagement structures are also contemplated. One or more engagement structures could also or instead be provided on one or more of the mixing channel 816, the atomizer 814, the stem 812, and/or a cap (not shown), for example.

**[00161]** Engagement structures could be useful, for example, for restricting a cartridge or vaporization device to a particular model or type of chamber. Engagement structures could also or instead be useful as an assembly aid, to ensure that chambers are assembled with chamber intake holes 918, 919 aligned with mixing channel intake holes 818, 819, for example.

**[00162]** Multiple chambers could be separated or partitioned by one or more partition walls. With reference to Fig. 8, a central partition between the chambers 802, 804 could be provided in part by partition wall sections 808, 810, in combination with the stem 812, the atomizer 814, and the mixing channel 816. A gasket or other sealing member could be provided between each partition wall section 808, 810 and the stem 812, the atomizer 814, the mixing channel 816, a cylindrical outer chamber wall in the example shown, and either a bottom wall of the chamber or a top surface of the base 806.

**[00163]** Partition wall sections such as 808, 810 could even be movable in some embodiments, to provide for adaptable partitioning of the interior space of a single cartridge chamber into multiple chambers. One or more sealing members could be attached to or otherwise carried by the partition wall sections to provide a seal between adjacent chambers at any position of the partition wall. Grooves, channels, or other structures could be provided in a cylindrical outer chamber wall and/or in one or more of the stem 812, the atomizer 814, the mixing channel 816, and a chamber bottom wall or top surface of the base 806 as guides to placement of partition walls at certain positions.

**[00164]** Chambers could also or instead be “self-contained”, as perhaps shown most clearly in Figs. 9 and 12. A self-contained chamber could include one or more exterior walls, and in particular a curved exterior wall in the example shown, and one or more interior partition walls. In Figs. 9 and 12, the partition walls have wall sections 902/904, 906/908, each of which abuts another partition wall section when the chambers 802, 804 are assembled together in a vaporization device or cartridge. The partition walls also have sections 910/911, 912/913, 914/915 to accommodate the stem 812, the atomizer 814, and the mixing channel 816, respectively. With self-contained chambers, a sealing member could be provided to seal the intake hole 918, 919 against leakage before a chamber is assembled in a vaporization device or cartridge. The mixing channel 816 could include a structure around a periphery or otherwise in the area of each of the intake holes 818, 819 to rupture or otherwise open a chamber intake hole seal when the chamber is installed in a cartridge, for example. A regulator that controls vaporization substance flow from a chamber for mixing could also or instead be used to reduce or avoid pre-assembly leakage from a chamber. A chamber intake hole seal could extend beyond a periphery of the chamber intake hole to provide a seal against leakage of a vaporization substance from an engagement between a chamber and the mixing channel 816. A separate gasket or other sealing member could be provided for this purpose, on the mixing chamber 816 or on a chamber 802, 804, for example.

**[00165]** Figs. 8 to 12 represent one example embodiment. Other embodiments are contemplated. For example, a cartridge with a uniform shape from the base to the top of each chamber could be preferred in order to simplify chamber construction or manufacturing. A size transition as shown in Figs. 8 to 12 between the mixing chamber 816 and the stem 812 could be avoided entirely or relocated into a cover or mouthpiece (not shown). A size transition could instead be made with a frustoconical interior wall, which could at least avoid sharp transitions between partition wall segments or parts. It should also be appreciated that a chamber need not necessarily conform tightly to other components. Tight conformance between components may be preferred to make efficient use of limited physical space, but in other embodiments multiple cylindrical chambers could be assembled to the same base, for example.

[00166] A central mixing channel 816 disposed between the chambers 802, 804 is shown in Figs. 8 to 12. In other embodiments, mixing could also or instead be performed in a mixing channel or reservoir in a base. For example, a base could have one or more input channels in fluid communication with multiple chambers, to feed vaporization substances into a base  
5 mixing channel, which is in fluid communication with a single atomizer. The atomizer could also be located in the base and in fluid communication with a stem.

[00167] Any of various types of engagement structures could be provided on or in a vaporization device. Fig. 13 is a cross-sectional and partially exploded view of an example of engagement structures in the multi-chamber cartridge of Fig. 8, along a part of line B--B in  
10 Fig. 11. In the embodiment illustrated in Fig. 13, the engagement structure 820 includes notches 1302 and 1304, and the complementary engagement structure 916 includes a protrusion 1300. Chambers that include a protrusion 1300, a protrusion (not shown) to engage the notch 1304, both of these protrusions, or no protrusion, could be used with the example engagement structure 820.

[00168] Engagement structures that are similar to or different from the examples shown in  
15 Fig. 13 could be more specific to particular types of chambers. One or more engagement structures on an apparatus such as a vaporization device could mechanically restrict chambers, cartridges, and/or other components to only specific types. An engagement structure could include one or more features, such as one or more protrusions and/or one or more grooves,  
20 with size(s), shape(s), and/or positions to mate only with a particular type of cooperating component with one or more complementary features. A specific threading and pin setup, so that only a specific cartridge type would fit only in an intended device, is another engagement structure example. One or more pins of a particular shape, such as hexagonal, represent a further example of engagement structures to provide cartridge / device specificity. This type  
25 of physical or mechanical specificity could be used, for example, to restrict a vaporization device to use with only certain types of chambers or cartridges, which could provide a measure of control over the particular vaporization substances that are available for vaporization by a vaporization device. Certain chambers or cartridges could be restricted to

certain positions, which could have regulators, power supply terminals, and/or other features that are specially adapted for those chambers or cartridges, for example.

**[00169]** Engagement structures need not have only a physical function such as controlling correct placement or alignment of a chamber and/or other component or limiting chambers  
5 and/or other components to particular types. Engagement structures on different chambers could have different sizes and/or patterns of conductive pins, for example, to enable a vaporization device to detect the type(s) of chambers that have been installed. With reference again to Fig 13, the protrusion 1300 could include a conductive pin and the notches 1302 and 1304 could include contacts, for example, to provide for detection of an installed chamber or  
10 cartridge and/or an installed chamber or cartridge type. Other embodiments are also contemplated, and the notches 1302 and 1304 could include pressure sensors or another type of sensor to detect the presence of a protrusion 1300.

**[00170]** In the example of Fig. 13, the presence of the protrusion 1300 aligned with the notch 1302 and the lack of a protrusion aligned with the notch 1304 could provide information  
15 regarding an installed chamber. This information could include the type of vaporization substance stored by the chamber, which could be used by a controller, in a base of a multi-chamber cartridge or elsewhere in a multi-chamber device, for example, to control the voltage, current, and/or power supplied to an atomizer. One or more regulators within a multi-chamber cartridge or device could also or instead be controlled based on the type of  
20 vaporization substance stored by the chamber.

**[00171]** Each different type of chamber that is compatible with a multi-chamber cartridge or device could have a unique engagement structure. The two notches 1302 and 1304 in Fig. 13 can detect a maximum of four different types of chambers, including chambers with no protrusions, chambers with two protrusions, chambers with only one protrusion 1300 as  
25 shown, and chambers with only one protrusion that corresponds to notch 1304. However, engagement structures with more or fewer notches could be used to enable detection of different numbers of chamber types.

**[00172]** The protrusions and notches illustrated in Fig. 13 are provided by way of example only. Other arrangements, sizes, and shapes of engagement structures that might or might not include protrusions and/or grooves are also contemplated. Although described above primarily in the context of chambers, engagement structures could also or instead be used in conjunction with cartridges and/or other components. Engagement structures are also not in any way limited to localized structures at certain locations on or in an apparatus or component. Different types of chamber or cartridge could have different shapes that will only fit into compartments, such as those shown at 313 in Fig. 4, for example, that have a complementary shape.

**[00173]** Embodiments described above relate primarily to multi-chamber apparatus such as cartridges or vaporization devices. Other embodiments, including methods, are also contemplated.

**[00174]** Fig. 14, for example, is a flow diagram illustrating a method 1400 according to an embodiment. The example method 1400 involves an operation 1402 of providing chambers to store vaporization substances, an operation 1404 of providing a mixer to mix the vaporization substances, and an operation 1406 of providing an atomizer to atomize a vaporization substance mixer. These operations 1402, 1404 and 1406 are shown separately for illustrative purposes, but need not be separate operations in all embodiments. For example, a vaporization device could include a mixer and an atomizer, and could also be sold with vaporization substance chambers as well. A vaporization device that is usable with multiple chambers, or components thereof, could potentially be provided separately from the chambers, which could be purchased separately, for example.

**[00175]** The chambers, mixer, and/or atomizer could be provided at 1402, 1404, 1406 by actually manufacturing these components. Any of these components, and/or other components, could instead be provided by purchasing or otherwise acquiring the components from one or more suppliers.

**[00176]** At least some components or parts thereof could be provided in different ways. Different cartridge parts, such as chambers, bases, covers, and atomizers, for example, could

be provided by manufacturing one or more parts and purchasing one or more other parts, or by purchasing different parts from different suppliers.

[00177] A mixer that is provided at 1404 could include an active mixer to receive and actively mix vaporization substances to form a vaporization substance mixture, or a passive  
5 mixer to receive vaporization substances and mix the vaporization substance with multiple mixing elements and form a vaporization substance mixture. Either of these types of mixer could include a mixing channel to receive the vaporization substances.

[00178] An active mixer could be or include a stirring element, such as any one or more of:  
10 a stirring element to be driven by an electric motor, a magnetic stirring element, and an acoustic stirring element, as disclosed by way of example elsewhere herein. Examples of passive mixers disclosed herein include mixing elements including a splitter to split a received stream of the vaporization substances into multiple streams and a combiner coupled to the splitter to combine the streams, wells, ridges, grooves, linear elements, and helical elements.

[00179] In some embodiments, components such as the mixer provided at 1404 and the  
15 atomizer provided at 1406, and possibly the chambers provided at 1402, are provided in the form of a pre-assembled vaporization device. In other embodiments, components are not necessarily assembled. Fig. 14 therefore also illustrates an operation 1408 of assembling components. This could involve, for example, arranging the atomizer in fluid communication with the mixer, such as by installing the atomizer and/or the mixer in a vaporization device or  
20 cartridge. Chambers could also or instead be assembled at 1408, by installing the chambers in a vaporization device or cartridge or otherwise arranging the chambers in fluid communication with the mixer.

[00180] The example method 1400 is illustrative of one embodiment. Examples of various  
25 ways to perform the illustrated operations, additional operations that may be performed in some embodiments, or operations that could be omitted in some embodiments, could be inferred or apparent from the description and drawings, for example. Further variations may be or become apparent.

**[00181]** For instance, other components could be provided and/or assembled. Examples of operations involving such other components include providing a channel for fluid communication with the atomizer, providing a mouthpiece for fluid communication with the channel, and providing the vaporization substances. A method could also or instead involve providing regulators to control movement of the vaporization substances to the mixer, and possibly also arranging the regulators in fluid communication with the mixer. A power controller to control power to the atomizer could also or instead be provided and coupled to the atomizer.

**[00182]** Providing the chambers at 1402 could involve providing at least one of the first chamber and the second chamber with an engagement structure to engage with a complementary engagement structure of the apparatus, in which case assembly at 1408 could involve arranging the at least one of the first chamber and the second chamber with the engagement structure engaging with the complementary engagement structure of the apparatus.

**[00183]** One or more components, such as chambers, could be refilled or replaced as shown at 1410.

**[00184]** Other variations of methods associated with manufacturing or otherwise producing a multi-chamber apparatus such as a cartridge or a vaporization device may be or become apparent.

**[00185]** User methods are also contemplated. Fig. 15 is a flow diagram illustrating a method according to another embodiment.

**[00186]** The example method 1500 involves an optional operation 1502 of installing or replacing one or more chambers. A user need not necessarily install or replace chambers every time a vaporization substance mixture is to be vaporized. The example method 1500 also involves an operation 1504 of initiating supply of vaporization substances to a mixer, and an operation 1506 of activating an atomizer. These operations could involve operating one or more input devices such as a control button or switch or even just inhaling on a mouthpiece.

The operations at 1504 and 1506 are shown separately in Fig. 15 solely for illustrative purposes, and need not necessarily be separate operations.

[00187] Similarly, inhaling vapor is shown separately at 1508, but in some embodiments inhaling on a mouthpiece initiates vaporization substance flow, mixing, and vaporization.

5 [00188] The dashed arrows in Fig. 15 illustrate that multiple doses of a vaporization substance mixture could be vaporized, and that available vaporization substances could be changed by installing or replacing one or more chambers.

[00189] The example method 1500, like the example method 1400, is an illustrative and non-limiting example. Various ways to perform the illustrated operations, additional  
10 operations that may be performed in some embodiments, or operations that could be omitted in some embodiments, could be inferred or apparent from the description and drawing or otherwise be or become apparent.

[00190] It should be appreciated that the drawings and description herein are intended solely for illustrative purposes, and that the present invention is in no way limited to the  
15 particular example embodiments explicitly shown in the drawings and described herein.

[00191] What has been described is merely illustrative of the application of principles of embodiments of the present disclosure. Other arrangements and methods can be implemented by those skilled in the art.

[00192] For example, various options for implementation of a mixer are described above,  
20 but other options are possible. With reference again to Fig. 5, although the mixer 536 is illustrated separately from the atomizer 538, in another embodiment a mixer is integrated with or otherwise combined with an atomizer. A mixer or vaporization substance mixing could be provided by a ceramic core, for example. To at least some extent, different vaporization substances that are exposed to a ceramic core or parts of a ceramic core, from different  
25 chambers for instance, may mix together as they flow or seep through the ceramic core. Other types and/or implementations of mixers may be or become apparent to those skilled in the art.

**[00193]** It should also be noted that features disclosed herein, whether in the context of apparatus, methods, and/or other embodiments, need not necessarily be implemented in combination with each other. In general, features may be implemented individually or in any of various combinations.

5 **[00194]** While the present invention has been described with reference to specific features and embodiments thereof, various modifications and combinations can be made thereto without departing from the invention. The description and drawings are, accordingly, to be regarded simply as an illustration of some embodiments of the invention as defined by the appended claims, and are contemplated to cover any and all modifications, variations,  
10 combinations or equivalents that fall within the scope of the present invention. Therefore, although the present invention and potential advantages have been described in detail, various changes, substitutions and alterations can be made herein without departing from the invention as defined by the appended claims. Moreover, the scope of the present application is not intended to be limited to the particular embodiments of any process, machine,  
15 manufacture, composition of matter, means, methods and steps described in the specification. As one of ordinary skill in the art will readily appreciate from the disclosure of the present invention, processes, machines, manufacture, compositions of matter, means, methods, or steps, presently existing or later to be developed, that perform substantially the same function or achieve substantially the same result as the corresponding embodiments described herein  
20 may be utilized according to the present invention. Accordingly, the appended claims are intended to include within their scope such processes, machines, manufacture, compositions of matter, means, methods, or steps.

We Claim:

1. An apparatus comprising:  
  
a mixer to receive and actively mix a plurality of vaporization substances to form a vaporization substance mixture; and  
  
5 an atomizer, in fluid communication with the mixer, to vaporize the vaporization substance mixture.
2. The apparatus of claim 1, further comprising:  
  
a plurality of chambers to store respective vaporization substances of the plurality of vaporization substances.
- 10 3. The apparatus of claim 1 or claim 2, further comprising:  
  
a channel in fluid communication with the atomizer.
4. The apparatus of claim 3, further comprising:  
  
a mouthpiece in fluid communication with the channel.
5. The apparatus of claim 2, wherein the plurality of chambers includes a  
15 chamber comprising an engagement structure to engage with a complementary engagement structure of the apparatus.
6. The apparatus of any one of claims 1 to 5, wherein at least one of the vaporization substances is a liquid.
7. The apparatus of any one of claims 1 to 6, wherein at least one of the  
20 vaporization substances is a dry substance.
8. The apparatus of any one of claims 1 to 7, wherein at least one of the vaporization substances is a wax.

9. The apparatus of any one of claims 1 to 8, wherein at least one of the vaporization substances is a gel.
10. The apparatus of any one of claims 1 to 9, further comprising:  
a plurality of regulators to control movement of the vaporization substances to  
5 the mixer.
11. The apparatus of claim 10, wherein the plurality of regulators includes a regulator comprising a wick.
12. The apparatus of claim 10, wherein the plurality of regulators includes a regulator comprising a valve.
- 10 13. The apparatus of claim 10, wherein the plurality of regulators includes a regulator comprising a pump.
14. The apparatus of claim 10, wherein the plurality of regulators includes a regulator comprising a mechanical feed structure.
- 15 15. The apparatus of claim 14, wherein the mechanical feed structure comprises a screw conveyor.
16. The apparatus of any one of claims 10 to 15, wherein the plurality of regulators provides dosage control for the apparatus.
17. The apparatus of any one of claims 1 to 16, further comprising:  
a power controller to control power to the atomizer.
- 20 18. The apparatus of any one of claims 10 to 17, wherein the mixer comprises a mixing channel to receive the vaporization substances.
19. The apparatus of any one of claims 1 to 18, wherein the mixer comprises a stirring element.

20. The apparatus of claim 19, wherein the stirring element is driven by an electric motor.
21. The apparatus of claim 19, wherein the stirring element comprises a magnetic stirring element.
- 5 22. The apparatus of claim 19, wherein the stirring element comprises an acoustic stirring element.
23. An apparatus comprising:
- a mixer to receive a plurality of vaporization substances, the mixer comprising a plurality of mixing elements to mix the vaporization substances and form a vaporization
- 10 substance mixture; and
- an atomizer, in fluid communication with the mixer, to vaporize the vaporization substance mixture.
24. The apparatus of claim 23, further comprising:
- a plurality of chambers to store respective vaporization substances of the
- 15 plurality of vaporization substances.
25. The apparatus of claim 23 or claim 24, further comprising:
- a channel in fluid communication with the atomizer.
26. The apparatus of claim 25, further comprising:
- a mouthpiece in fluid communication with the channel.
- 20 27. The apparatus of claim 24, wherein the plurality of chambers includes a chamber comprising an engagement structure to engage with a complementary engagement structure of the apparatus.
28. The apparatus of any one of claims 23 to 27, further comprising:

a plurality of regulators to control movement of the vaporization substances to the mixer.

29. The apparatus of claim 28, wherein the plurality of regulators includes a regulator comprising a wick.

5 30. The apparatus of claim 28, wherein the plurality of regulators includes a regulator comprising a valve.

31. The apparatus of claim 28, wherein the plurality of regulators includes a regulator comprising a pump.

10 32. The apparatus of claim 28, wherein the plurality of regulators includes a regulator comprising a mechanical feed structure.

33. The apparatus of claim 32, wherein the mechanical feed structure comprises a screw conveyor.

34. The apparatus of any one of claims 28 to 33, wherein the plurality of regulators provides dosage control for the apparatus.

15 35. The apparatus of any one of claims 23 to 34, further comprising:  
a power controller to control power to the atomizer.

36. The apparatus of any one of claims 23 to 35, wherein the mixer comprises a mixing channel to receive the vaporization substances.

17 37. The apparatus of claim 36, wherein the plurality of mixing elements comprises:  
20 a splitter to split a stream comprising the vaporization substances into a plurality of streams; and  
a combiner, coupled to the splitter, to combine the plurality of streams.

38. The apparatus of any one of claims 23 to 37, wherein the plurality of mixing elements comprises wells.
39. The apparatus of any one of claims 23 to 38, wherein the plurality of mixing elements comprises ridges.
- 5 40. The apparatus of any one of claims 23 to 39, wherein the plurality of mixing elements comprises grooves.
41. The apparatus of any one of claims 23 to 40, wherein the plurality of mixing elements comprises linear elements.
42. The apparatus of any one of claims 23 to 41, wherein the plurality of mixing  
10 elements comprises helical elements.
43. A method comprising:
- providing a mixer to receive and actively mix a plurality of vaporization substances to form a vaporization substance mixture; and
- providing an atomizer to vaporize the vaporization substance mixture.
- 15 44. The method of claim 43, further comprising:
- arranging the atomizer in fluid communication with the mixer.
45. The method of claim 43 or claim 44, further comprising:
- providing a plurality of chambers to store respective vaporization substances of the plurality of vaporization substances.
- 20 46. The method of claim 45, further comprising:
- arranging the plurality of chambers in fluid communication with the mixer.
47. The method of any one of claims 43 to 46, further comprising:

providing a channel for fluid communication with the atomizer.

48. The method of claim 47, further comprising:

providing a mouthpiece for fluid communication with the channel.

49. The method of any one of claims 43 to 48, further comprising:

5 providing the plurality of vaporization substances.

50. The method of any one of claims 43 to 49, wherein the vaporization substances comprise any one or more of: a liquid, a dry substance, a wax, and a gel.

51. The method of any one of claims 43 to 50, further comprising:

10 providing a plurality of regulators to control movement of the vaporization substances to the mixer.

52. The method of claim 51, further comprising:

arranging the plurality of regulators in fluid communication with the mixer.

53. The method of claim 51 or claim 52, wherein the regulators include any one or more of: a regulator comprising a wick, a regulator comprising a valve, a regulator comprising  
15 a pump, and a regulator comprising a mechanical feed structure.

54. The method of any one of claims 43 to 53, further comprising:

providing a power controller to control power to the atomizer.

55. The method of claim 54, further comprising:

coupling the power controller to the atomizer.

20 56. The method of any one of claims 43 to 55, wherein the mixer comprises a mixing channel to receive the vaporization substances.

57. The method of any one of claims 43 to 56, wherein the mixer comprises a stirring element.
58. The method of claim 57, wherein the stirring element comprises any one or more of: a stirring element to be driven by an electric motor, a magnetic stirring element, and  
5 an acoustic stirring element.
59. A method comprising:
- providing a mixer to receive and mix a plurality of vaporization substances, the mixer comprising a plurality of mixing elements to mix the vaporization substances and form a vaporization substance mixture; and
- 10 providing an atomizer to vaporize the vaporization substance mixture.
60. The method of claim 59, further comprising:
- arranging the atomizer in fluid communication with the mixer.
61. The method of claim 59 or claim 60, further comprising:
- providing a plurality of chambers to store respective vaporization substances of  
15 the plurality of vaporization substances.
62. The method of claim 61, further comprising:
- arranging the plurality of chambers in fluid communication with the mixer.
63. The method of any one of claims 59 to 62, further comprising:
- providing a channel for fluid communication with the atomizer.
- 20 64. The method of claim 63, further comprising:
- providing a mouthpiece for fluid communication with the channel.
65. The method of any one of claims 59 to 64, further comprising:

providing the plurality of vaporization substances.

66. The method of any one of claims 59 to 65, wherein the vaporization substances comprise any one or more of: a liquid, a dry substance, a wax, and a gel.

67. The method of any one of claims 59 to 66, further comprising:

5 providing a plurality of regulators to control movement of the vaporization substances to the mixer.

68. The method of claim 67, further comprising:

arranging the plurality of regulators in fluid communication with the mixer.

69. The method of claim 67 or claim 68, wherein the regulators include any one or  
10 more of: a regulator comprising a wick, a regulator comprising a valve, a regulator comprising a pump, and a regulator comprising a mechanical feed structure.

70. The method of any one of claims 59 to 69, further comprising:

providing a power controller to control power to the atomizer.

71. The method of claim 70, further comprising:

15 coupling the power controller to the atomizer.

72. The method of any one of claims 59 to 71, wherein the mixer comprises a mixing channel to receive the vaporization substances.

73. The method of any one of claims 59 to 72, wherein the plurality of mixing elements comprises:

20 a splitter to split a stream comprising the vaporization substances into a plurality of streams; and

a combiner, coupled to the splitter, to combine the plurality of streams.

74. The method of any one of claims 59 to 73, wherein the plurality of mixing elements comprises any one or more of: wells, ridges, grooves, linear elements, and helical elements.

75. A method of use of the apparatus of any one of claims 1 to 42, the method  
5 comprising:

initiating supply of the plurality of vaporization substances to the mixer;

initiating vaporization of the vaporization substance mixture by the atomizer to  
produce vapor;

inhaling the vapor.

10 76. A method comprising:

initiating supply of a plurality of vaporization substances to a mixer for active  
mixing of the vaporization substances to form a vaporization substance mixture;

initiating vaporization of the vaporization substance mixture by an atomizer to  
produce vapor;

15 inhaling the vapor.

77. A method comprising:

initiating supply of a plurality of vaporization substances to a mixer that  
comprises a plurality of mixing elements to mix the vaporization substances and form a  
vaporization substance mixture;

20 initiating vaporization of the vaporization substance mixture by an atomizer to  
produce vapor;

inhaling the vapor.

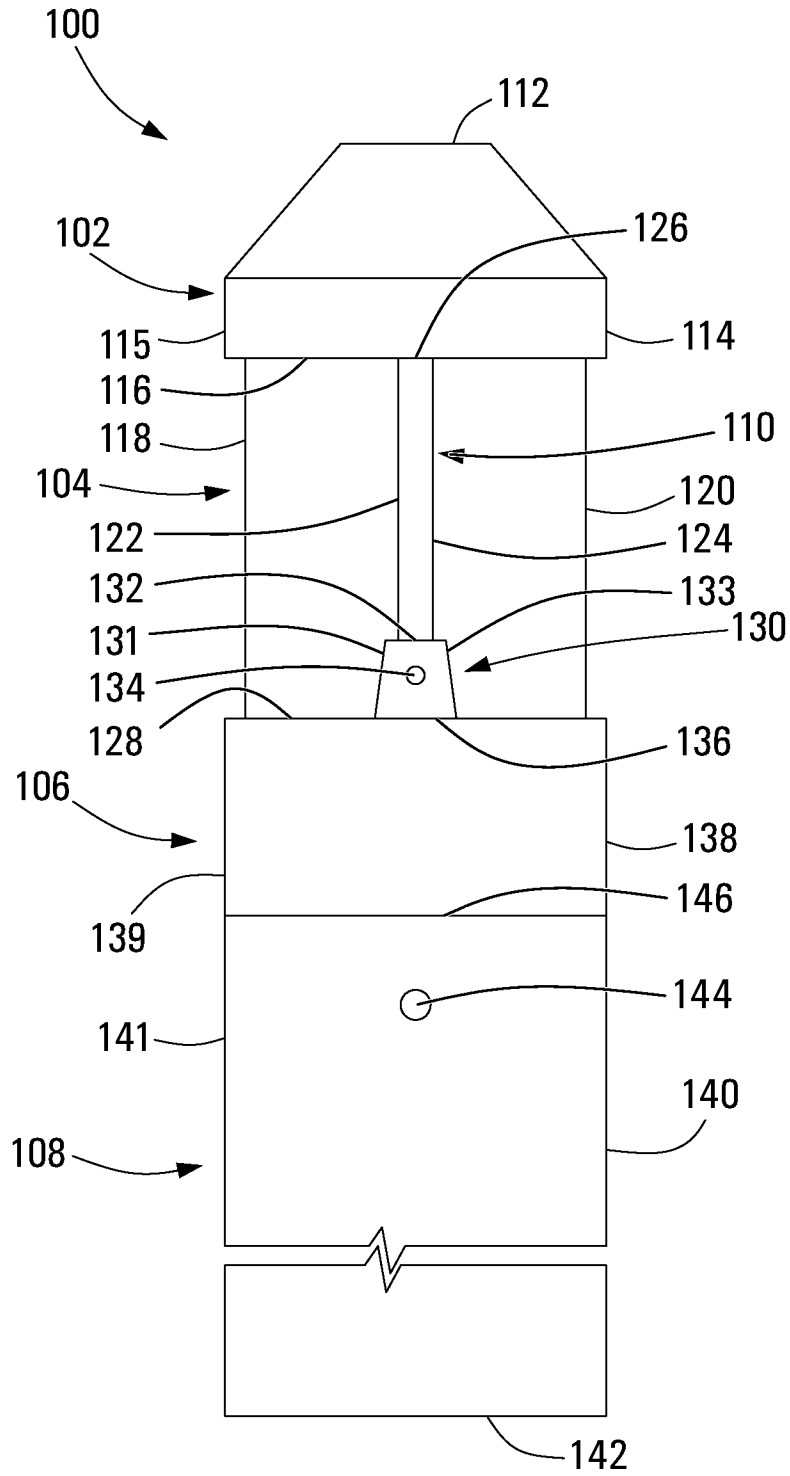

**FIG. 1**

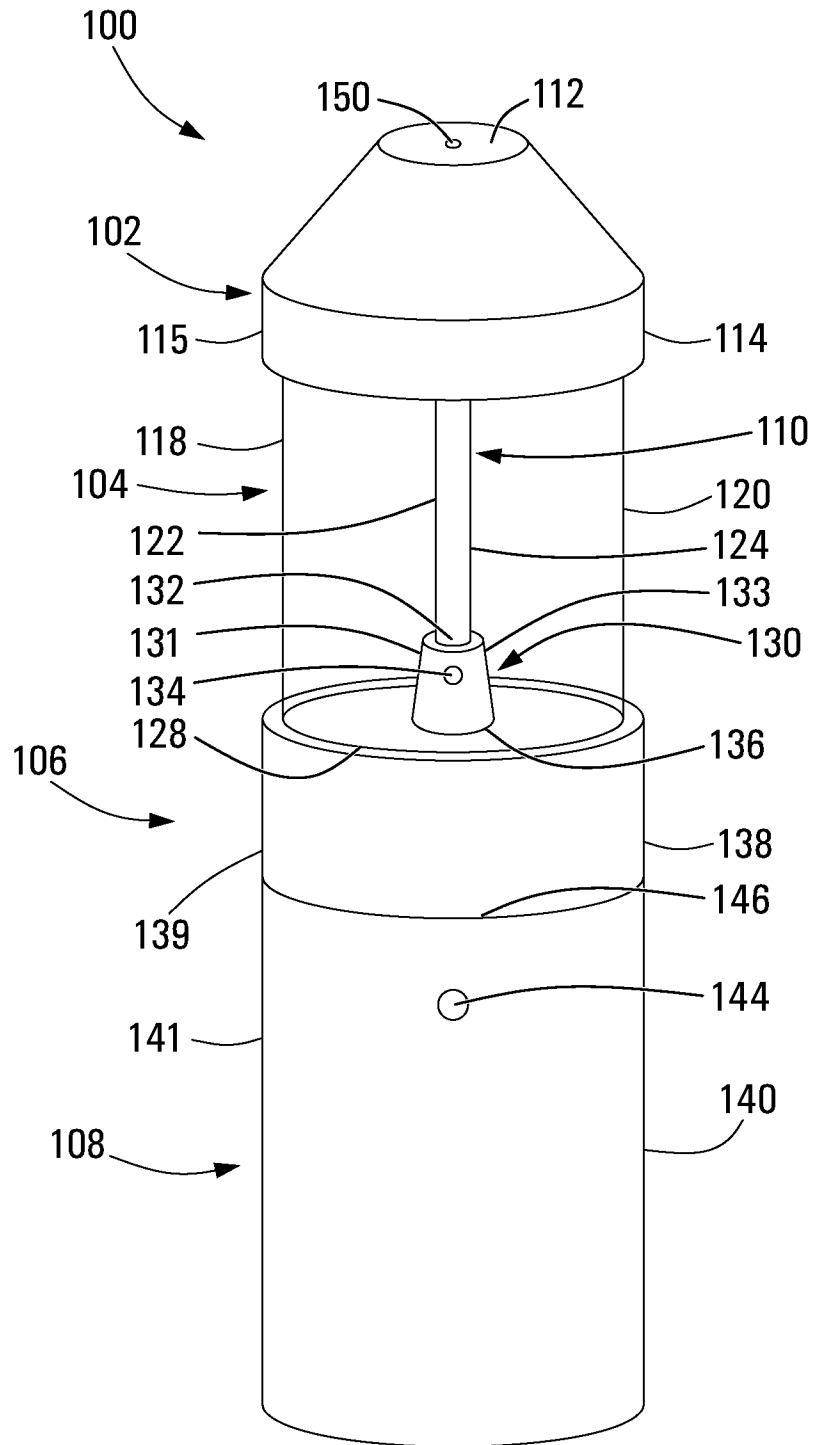

**FIG. 2**

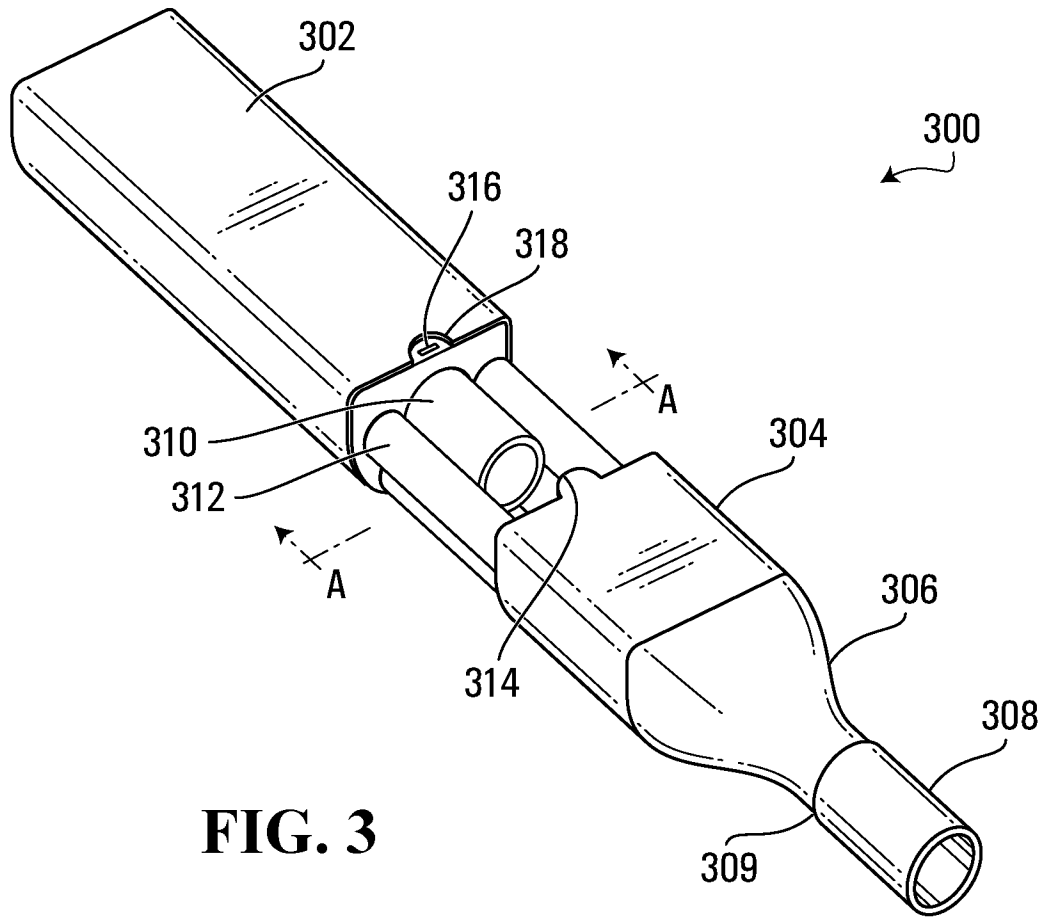

**FIG. 3**

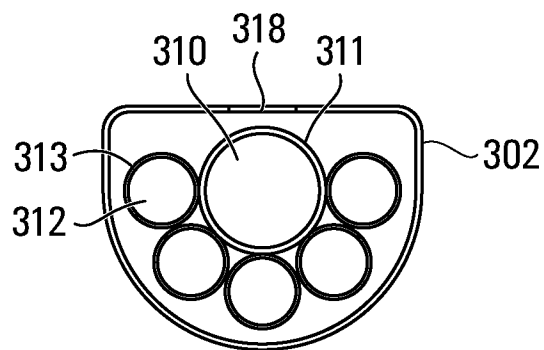

**FIG. 4**

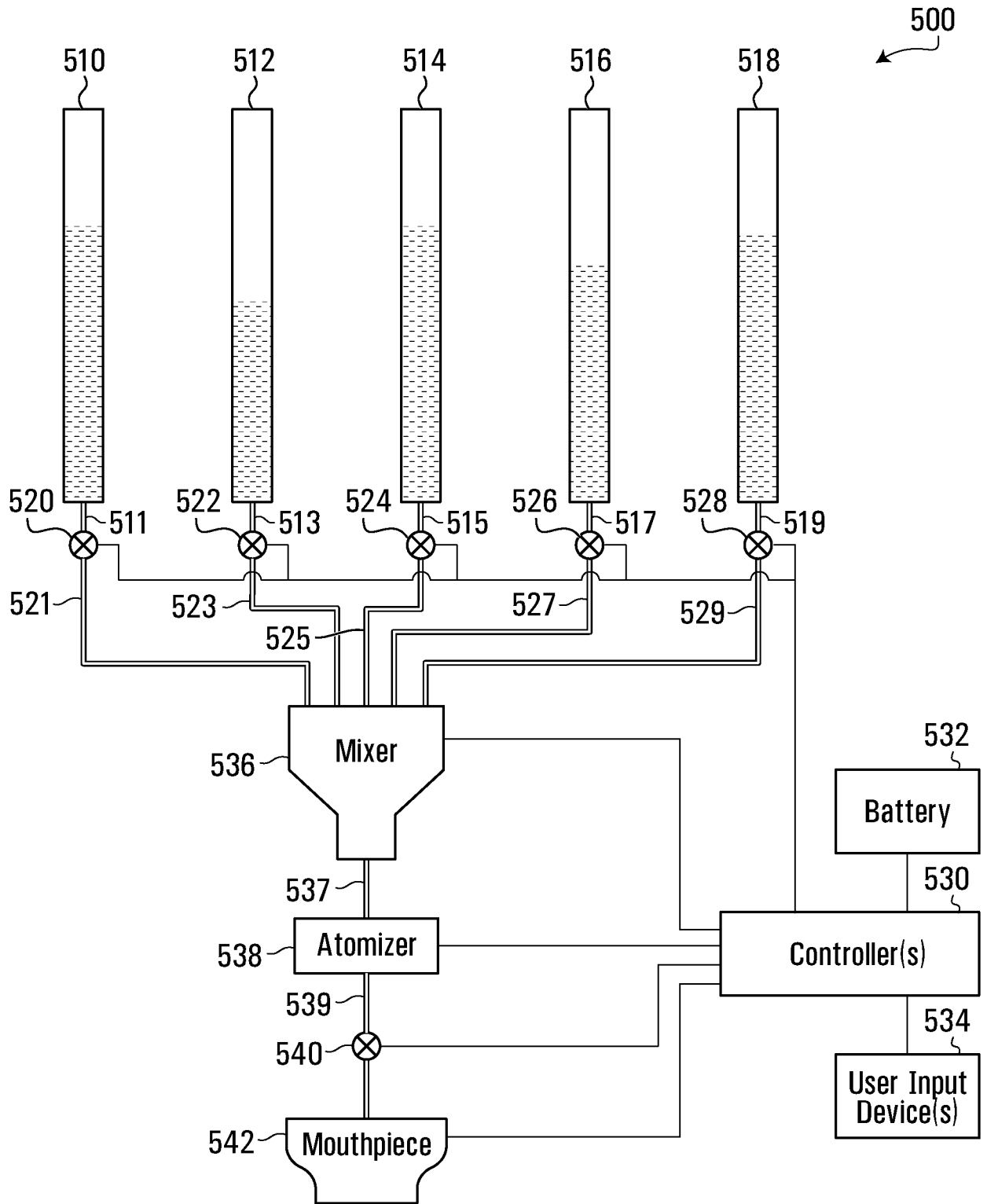
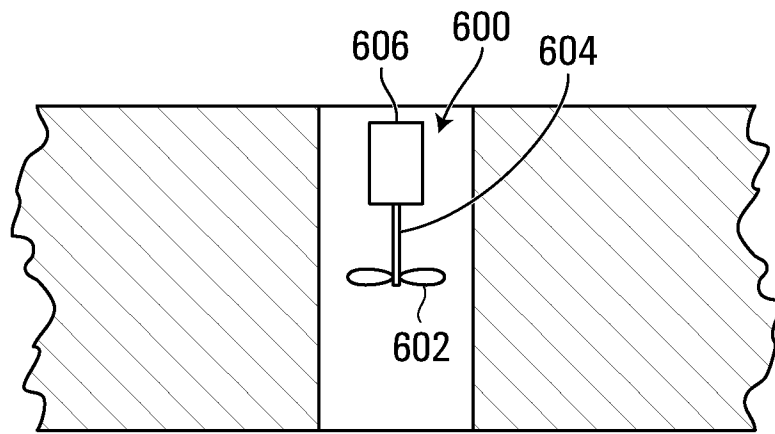
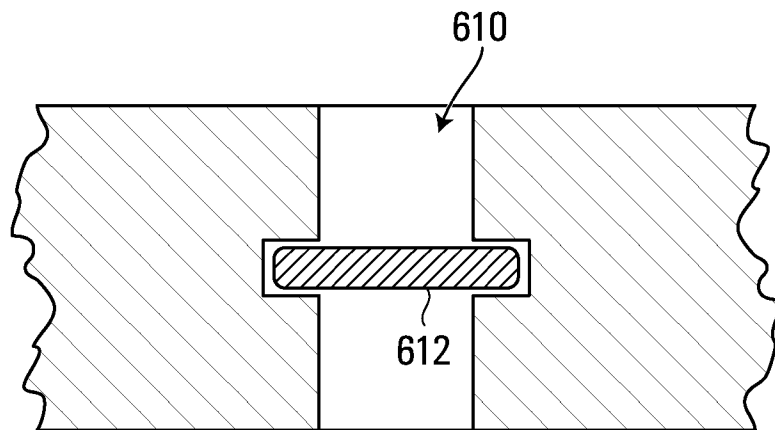

FIG. 5



**FIG. 6A**



**FIG. 6B**

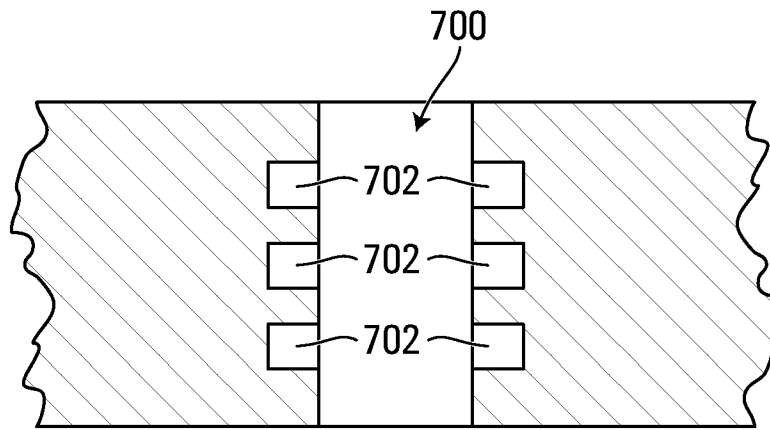

**FIG. 7A**

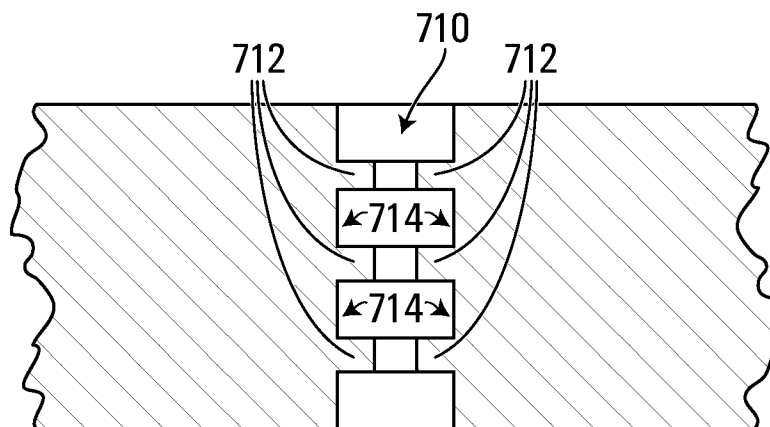

**FIG. 7B**

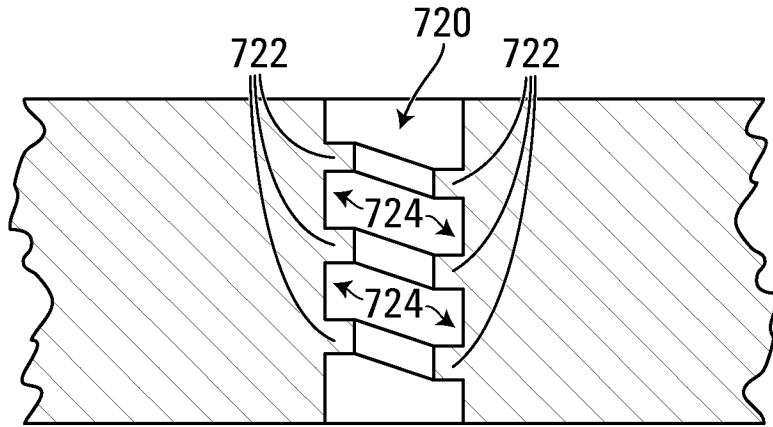

**FIG. 7C**

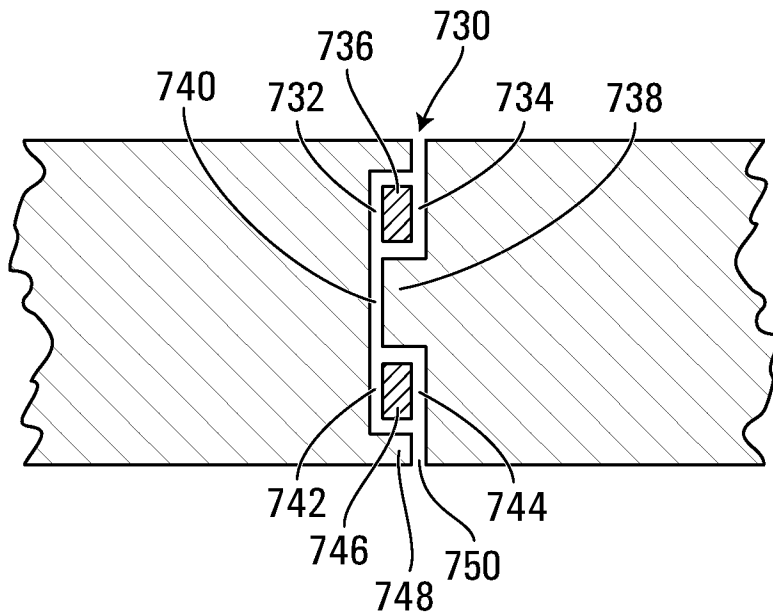

**FIG. 7D**

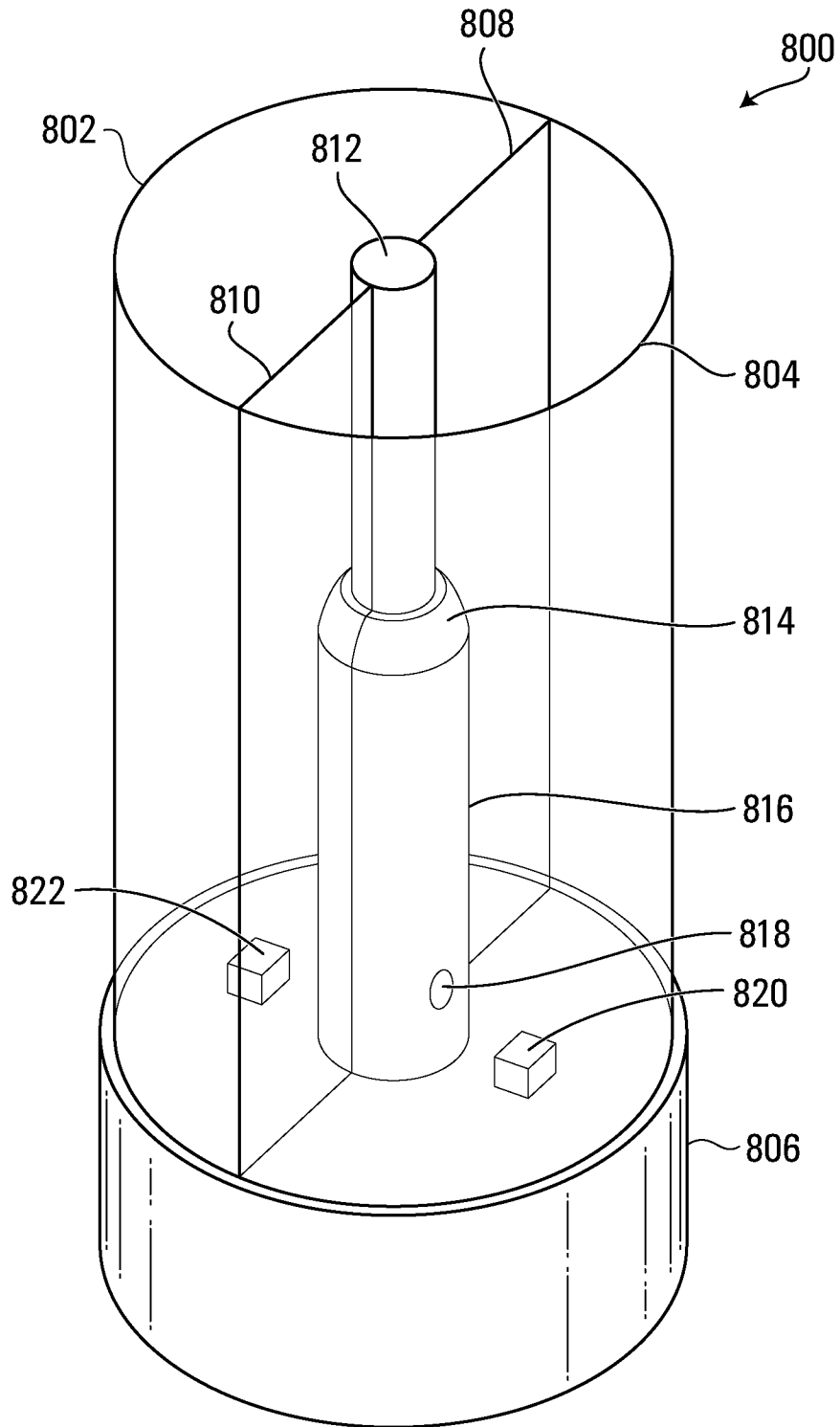

**FIG. 8**

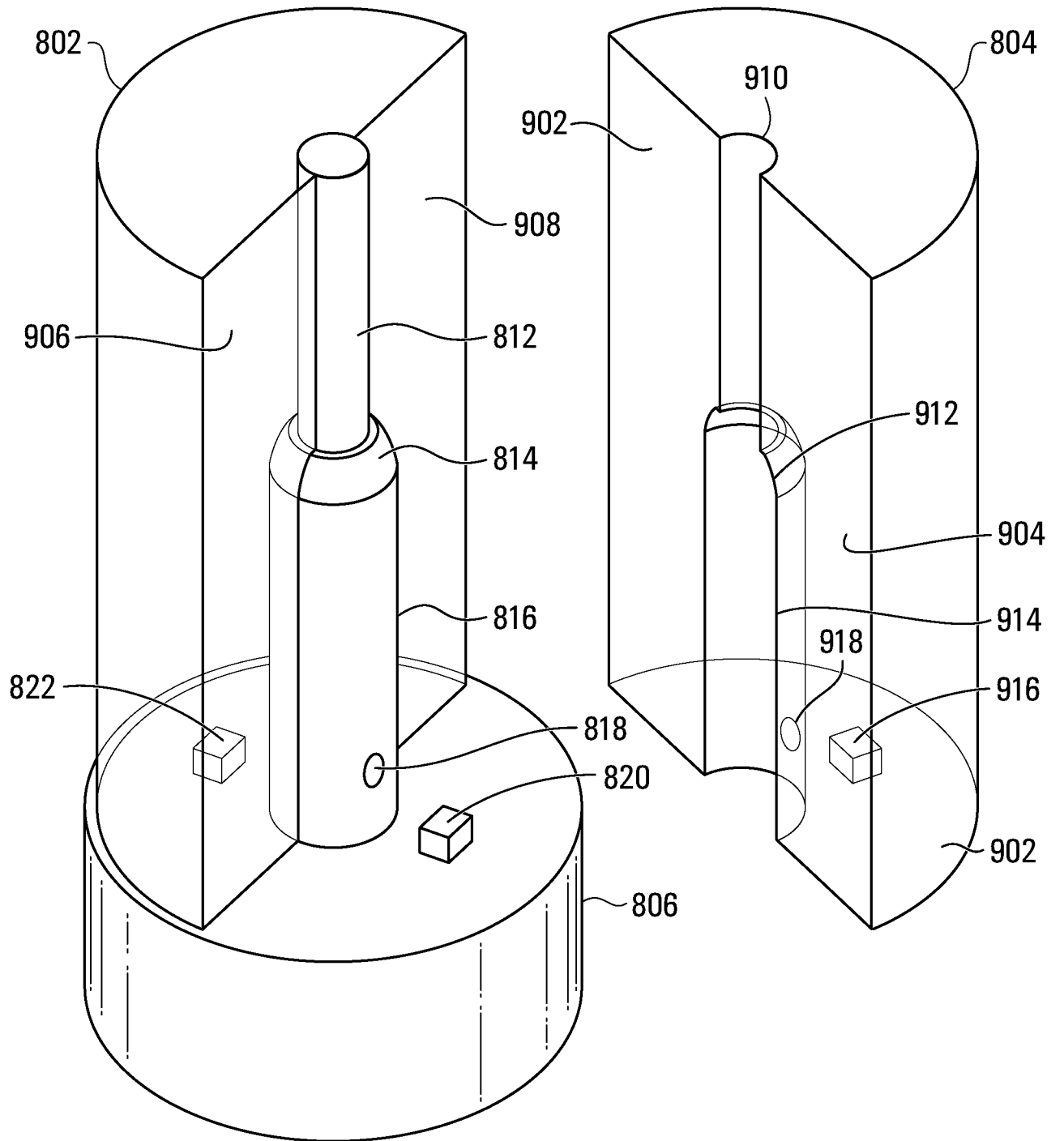

**FIG. 9**

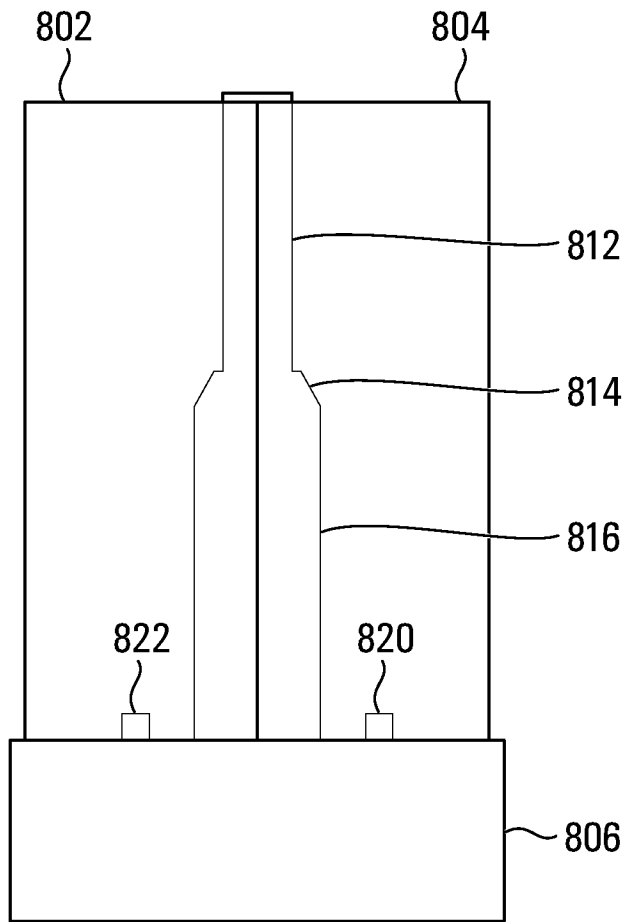

**FIG. 10**

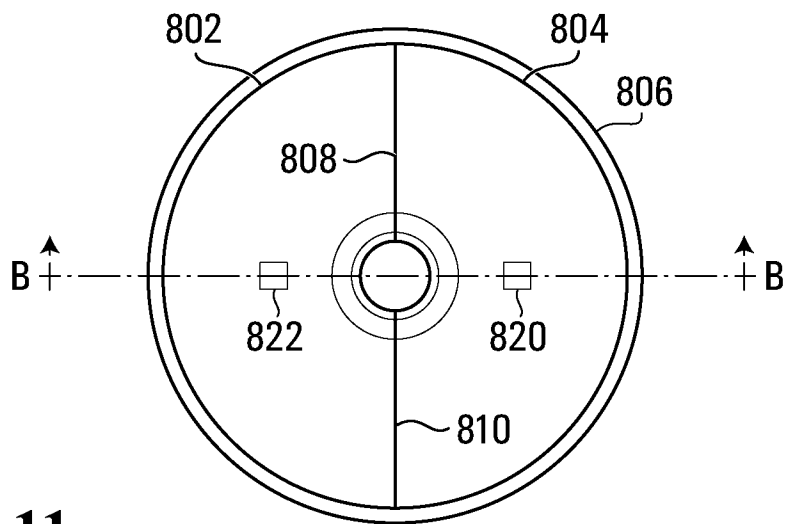

**FIG. 11**

11/13

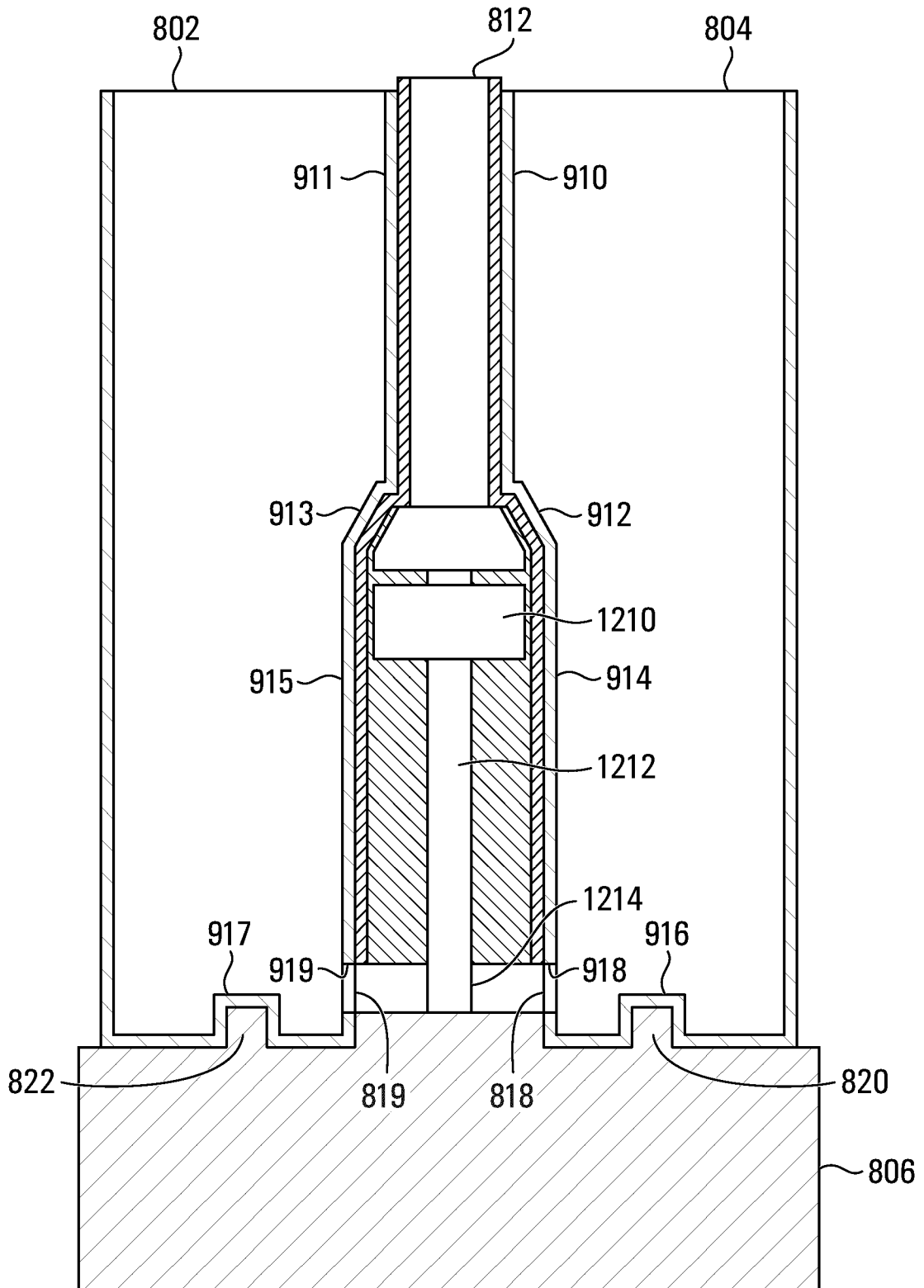
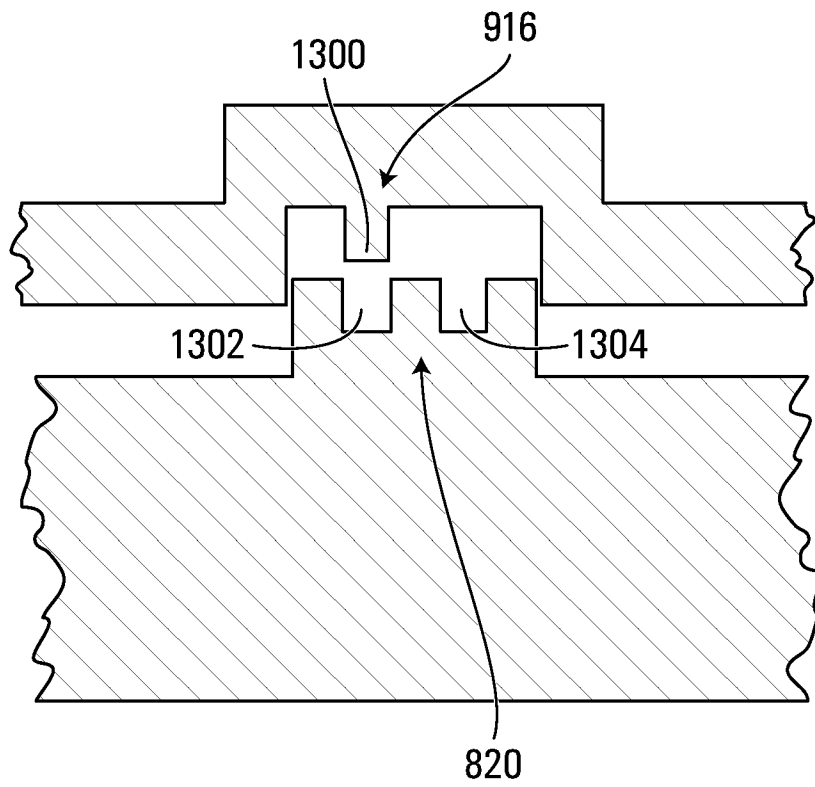
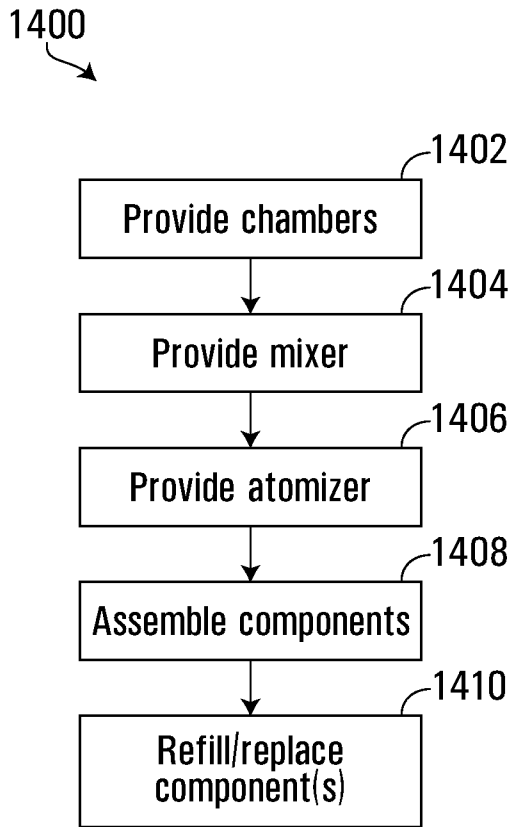

FIG. 12

12/13



**FIG. 13**



**FIG. 14**

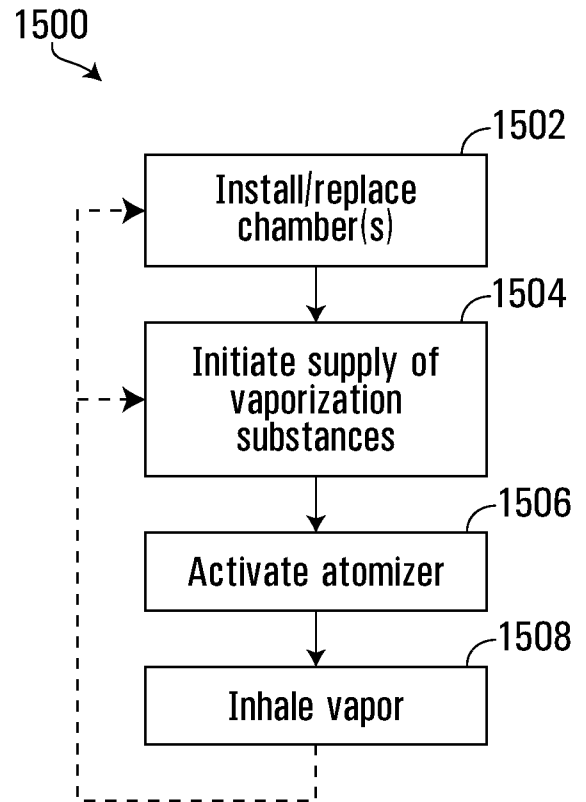

**FIG. 15**

## INTERNATIONAL SEARCH REPORT

International application No.

**PCT/CA2019/051631**

A. CLASSIFICATION OF SUBJECT MATTER  
 IPC: *A24F 47/00* (2006.01), *A61M 11/00* (2006.01), *A61M 15/06* (2006.01)

According to International Patent Classification (IPC) or to both national classification and IPC

## B. FIELDS SEARCHED

Minimum documentation searched (classification system followed by classification symbols)  
 IPC: *A24F 47/00* (2006.01), *A61M 11/00* (2006.01), *A61M 15/06* (2006.01)

Documentation searched other than minimum documentation to the extent that such documents are included in the fields searched

Electronic database(s) consulted during the international search (name of database(s) and, where practicable, search terms used)  
 Canadian Patents Database, Questel-Orbit (FamPat)  
 Keywords : mixer, atomizer, plural+, chamber+, stir+, screw, conveyor

## C. DOCUMENTS CONSIDERED TO BE RELEVANT

Category*	Citation of document, with indication, where appropriate, of the relevant passages	Relevant to claim No.
X Y	US2016337362A1 (CAMERON J.) 17 November 2016 (17-11-2016) *Abstract; para0092; Fig. 3*	1-18, 22, 43-56 19-21, 23-42, 57-74
Y	CN107173849A (ZHOU H., et al) 19 September 2017 (19-09-2017) * Translation from Chinese to English using Questel-Orbit* *Abstract; para0047*	19-21, 23-42, 57-74
A	CN108420112A (YAO H., et al) 21 August 2018 (21-08-2018) * Translation from Chinese to English using Questel-Orbit* * Abstract *	1, 23, 43, 59

Further documents are listed in the continuation of Box C.

See patent family annex.

* Special categories of cited documents: "A" document defining the general state of the art which is not considered to be of particular relevance "D" document cited by the applicant in the international application "E" earlier application or patent but published on or after the international filing date "L" document which may throw doubts on priority claim(s) or which is cited to establish the publication date of another citation or other special reason (as specified) "O" document referring to an oral disclosure, use, exhibition or other means "P" document published prior to the international filing date but later than the priority date claimed	"T" later document published after the international filing date or priority date and not in conflict with the application but cited to understand the principle or theory underlying the invention "X" document of particular relevance; the claimed invention cannot be considered novel or cannot be considered to involve an inventive step when the document is taken alone "Y" document of particular relevance; the claimed invention cannot be considered to involve an inventive step when the document is combined with one or more other such documents, such combination being obvious to a person skilled in the art "&" document member of the same patent family
--	--

Date of the actual completion of the international search  
 10 January 2020 (10-01-2020)

Date of mailing of the international search report  
 22 January 2020 (22-01-2020)

Name and mailing address of the ISA/CA  
 Canadian Intellectual Property Office  
 Place du Portage I, C114 - 1st Floor, Box PCT  
 50 Victoria Street  
 Gatineau, Quebec K1A 0C9  
 Facsimile No.: 819-953-2476

Authorized officer

William Tse (819) 639-7914

## INTERNATIONAL SEARCH REPORT

International application No.

**PCT/CA2019/051631****Box No. II Observations where certain claims were found unsearchable (Continuation of item 2 of the first sheet)**

This international search report has not been established in respect of certain claims under Article 17(2)(a) for the following reasons:

1.  Claim Nos.: 75-77  
because they relate to subject matter not required to be searched by this Authority, namely:

**Claims 75-77** do not comply with **Rule 39.1(iv) of the PCT**. No International Searching Authority shall be required to search an international application if, and to the extent to which, its subject matter is directed to methods for treatment of the human or animal body by surgery or therapy, as well as diagnostic methods.

In this case, it is considered that one skilled in the art would consider the step of inhaling the vapor (last steps of claims 75, 76, 77) to be human therapy, as the description does not restrict vapors to non-therapeutic substances. Indeed, the description describes the source of vapor as being from cannabis or herbs (para0003), which one skilled in the art would consider specifically for human therapy.

2.  Claim Nos.:  
because they relate to parts of the international application that do not comply with the prescribed requirements to such an extent that no meaningful international search can be carried out, specifically:

3.  Claim Nos.:  
because they are dependent claims and are not drafted in accordance with the second and third sentences of Rule 6.4(a).

**Box No. III Observations where unity of invention is lacking (Continuation of item 3 of first sheet)**

This International Searching Authority found multiple inventions in this international application, as follows:

1.  As all required additional search fees were timely paid by the applicant, this international search report covers all searchable claims.
2.  As all searchable claims could be searched without effort justifying additional fees, this Authority did not invite payment of additional fees.
3.  As only some of the required additional search fees were timely paid by the applicant, this international search report covers only those claims for which fees were paid, specifically claim Nos.:
4.  No required additional search fees were timely paid by the applicant. Consequently, this international search report is restricted to the invention first mentioned in the claims; it is covered by claim Nos.:

- Remark on Protest**
- The additional search fees were accompanied by the applicant's protest and, where applicable, the payment of a protest fee.
- The additional search fees were accompanied by the applicant's protest but the applicable protest fee was not paid within the time limit specified in the invitation.
- No protest accompanied the payment of additional search fees.

**INTERNATIONAL SEARCH REPORT**

International application No.

**PCT/CA2019/051631**

Patent Document Cited in Search Report	Publication Date	Patent Family Member(s)	Publication Date
US2016337362A1	17 November 2016 (17-11-2016)	US2016337362A1 CN108348001A WO2016187123A2 WO2016187123A3	17 November 2016 (17-11-2016) 31 July 2018 (31-07-2018) 24 November 2016 (24-11-2016) 23 March 2017 (23-03-2017)
CN107173849A	19 September 2017 (19-09-2017)	CN107173849A CN107173849B	19 September 2017 (19-09-2017) 22 November 2019 (22-11-2019)
CN108420112A	21 August 2018 (21-08-2018)	CN108420112A WO2019184468A1	21 August 2018 (21-08-2018) 03 October 2019 (03-10-2019)