

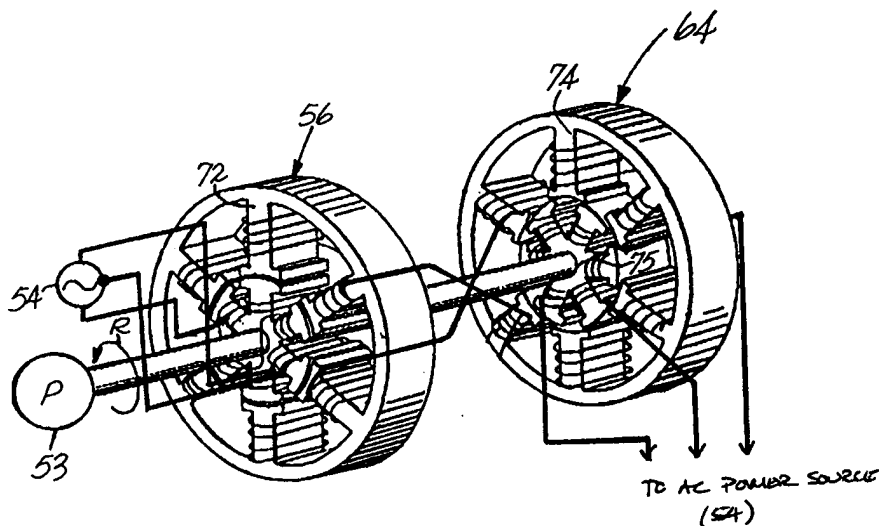

## INTERNATIONAL APPLICATION PUBLISHED UNDER THE PATENT COOPERATION TREATY (PCT)

<p>(51) International Patent Classification <sup>6</sup> : H02P 9/00, H02K 17/10</p>	A1	<p>(11) International Publication Number: <b>WO 98/37623</b></p> <p>(43) International Publication Date: 27 August 1998 (27.08.98)</p>
<p>(21) International Application Number: PCT/US98/02651</p> <p>(22) International Filing Date: 6 February 1998 (06.02.98)</p> <p>(30) Priority Data: 60/037,723 7 February 1997 (07.02.97) US</p> <p>(71) Applicant (for all designated States except US): THE ESTATE OF LEO G. NICKOLADZE, DECEASED [US/US]; 1155 Kahili Street, Kahili, HI 96734 (US).</p> <p>(71) Applicant (for US only): MARKS, Hildegard, K. (executrix for the deceased inventor) [US/US]; 1155 Kahili Street, Kahili, HI 96734 (US).</p> <p>(72) Inventor: NICKOLADZE, Leo, G. (deceased).</p> <p>(74) Agent: GELFOUND, Craig, A.; Christie, Parker &amp; Hale, LLP, P.O. Box 7068, Pasadena, CA 91109-7068 (US).</p>		<p>(81) Designated States: AL, AM, AT, AU, AZ, BA, BB, BG, BR, BY, CA, CH, CN, CU, CZ, DE, DK, EE, ES, FI, GB, GE, GH, GM, GW, HU, ID, IL, IS, JP, KE, KG, KP, KR, KZ, LC, LK, LR, LS, LT, LU, LV, MD, MG, MK, MN, MW, MX, NO, NZ, PL, PT, RO, RU, SD, SE, SG, SI, SK, SL, TJ, TM, TR, TT, UA, UG, US, UZ, VN, YU, ZW, ARIPO patent (GH, GM, KE, LS, MW, SD, SZ, UG, ZW), Eurasian patent (AM, AZ, BY, KG, KZ, MD, RU, TJ, TM), European patent (AT, BE, CH, DE, DK, ES, FI, FR, GB, GR, IE, IT, LU, MC, NL, PT, SE), OAPI patent (BF, BJ, CF, CG, CI, CM, GA, GN, ML, MR, NE, SN, TD, TG).</p> <p><b>Published</b> With international search report. Before the expiration of the time limit for amending the claims and to be republished in the event of the receipt of amendments.</p>

(54) Title: METHOD AND APPARATUS FOR COMPENSATING A LINE SYNCHRONOUS GENERATOR



## (57) Abstract

A line synchronous generator with an exciter and generator stage. The exciter stage includes an exciter stator (28) and an exciter rotor (32), and the generator stage includes a generator stator (26) and generator rotor (34). In one embodiment, the stators are wound with primary windings for connection to an AC power source and the rotors are wound with secondary windings (Figure 2). In an alternative embodiment, the rotors are wound with primary windings for connection to the AC power source and the stators are wound with secondary windings (Figure 3). The proper phase angle alignment of the secondary windings are determined by connecting the primary windings of the exciter and generator stages to the AC power source, and connecting a secondary winding of the exciter stage to a secondary winding of the generator stage. The remaining open secondary leads are then tested for two pairs having a voltage equal to two times the line voltage, and two pairs having a voltage equal to  $\sqrt{3}$  times the line voltage. The two pairs of open secondary leads having a voltage equal to two times the line voltage are connected together.

**FOR THE PURPOSES OF INFORMATION ONLY**

Codes used to identify States party to the PCT on the front pages of pamphlets publishing international applications under the PCT.

AL	Albania	ES	Spain	LS	Lesotho	SI	Slovenia
AM	Armenia	FI	Finland	LT	Lithuania	SK	Slovakia
AT	Austria	FR	France	LU	Luxembourg	SN	Senegal
AU	Australia	GA	Gabon	LV	Latvia	SZ	Swaziland
AZ	Azerbaijan	GB	United Kingdom	MC	Monaco	TD	Chad
BA	Bosnia and Herzegovina	GE	Georgia	MD	Republic of Moldova	TG	Togo
BB	Barbados	GH	Ghana	MG	Madagascar	TJ	Tajikistan
BE	Belgium	GN	Guinea	MK	The former Yugoslav Republic of Macedonia	TM	Turkmenistan
BF	Burkina Faso	GR	Greece	ML	Mali	TR	Turkey
BG	Bulgaria	HU	Hungary	MN	Mongolia	TT	Trinidad and Tobago
BJ	Benin	IE	Ireland	MR	Mauritania	UA	Ukraine
BR	Brazil	IL	Israel	MW	Malawi	UG	Uganda
BY	Belarus	IS	Iceland	MX	Mexico	US	United States of America
CA	Canada	IT	Italy	NE	Niger	UZ	Uzbekistan
CF	Central African Republic	JP	Japan	NL	Netherlands	VN	Viet Nam
CG	Congo	KE	Kenya	NO	Norway	YU	Yugoslavia
CH	Switzerland	KG	Kyrgyzstan	NZ	New Zealand	ZW	Zimbabwe
CI	Côte d'Ivoire	KP	Democratic People's Republic of Korea	PL	Poland		
CM	Cameroon	KR	Republic of Korea	PT	Portugal		
CN	China	KZ	Kazakstan	RO	Romania		
CU	Cuba	LC	Saint Lucia	RU	Russian Federation		
CZ	Czech Republic	LI	Liechtenstein	SD	Sudan		
DE	Germany	LK	Sri Lanka	SE	Sweden		
DK	Denmark	LR	Liberia	SG	Singapore		
EE	Estonia						

1

## METHOD AND APPARATUS FOR COMPENSATING A LINE SYNCHRONOUS GENERATOR

5

### CROSS-REFERENCE TO RELATED APPLICATIONS

10

The present application claims priority under 35 U.S.C. § 119(e) to co-pending provisional application, serial no. 60/037,723, filed February 7, 1997, entitled "Method and Apparatus for Compensating Line Synchronous Generators, which is expressly incorporated herein by reference as though fully set forth.

### FIELD OF THE INVENTION

15

The present invention relates generally to an electrical generator, and more particularly, to an improved induction generator referenced to an AC power source.

### BACKGROUND OF THE INVENTION

20

Recently, brought on by the shortage in fossil fuel and the ecological consequences of such use, various proposals have been devised for inserting locally generated electrical power into a public utility grid. An assortment of renewable fuel sources have been investigated. The ideal alternative energy fuel source will not have an adverse impact on the ecology and will result in a high grade fuel at a low cost. Common examples of alternative energy fuel sources are wind, hydro, hydrocarbon gas recovery, solar, geothermal and waste heat recovery. Each of these fuel sources may be teamed with electrical power generators.

25

30

35

The difficulty in utilizing these fuel sources lies in the quality of the fuel itself. For example, variations in wind velocity severely limit the usefulness of wind power machines as a steady and constant fuel source for a conventional synchronous or induction generator. This is because conventional generators can deliver usable power only when they operate within a particular speed range. As a result, the wind power machines must employ doubly wound AC generators, or elaborate propeller pitch control and mechanical drive systems that provide appropriate generator speed. To be of practical use, however, doubly-fed systems must provide appropriate rotor excitation and maintain constant stator voltage, which is not easily accomplished. Where high speed geothermal turbines or low speed water wheels are employed, mechanical speed control, reduction, or step-up devices must be used to provide the appropriate rotational speed for AC generation. The efficiency losses which accompany these types of mechanical conversion devices compromise their economic viability and render them generally unsuitable as sources of power.

1

The compensation provided by these mechanical conversion systems are essential, however, because the insertion of locally generated electrical power into a public utility grid requires exact phase and frequency matching. Accordingly, if a device could be self-synchronizing and tolerant of widely varying rotational speed, the use of alternative fuel sources as a means for generating electricity would be greatly enhanced. One noteworthy example of such a self-synchronizing rotating device can be found in several patents issued to Leo Nickoladze, specifically in U.S. Patents 4,701,691 and 4,229,689 which are expressly incorporated herein by reference as though fully set forth.

10

These latter examples rely on electrical cancellation within the inductive device itself whereby all variations in input power are effectively taken out. An exemplary embodiment of such induction device is shown in FIG. 1. The induction generator of FIG. 1 includes two stages, an exciter stage 10 and a generator stage 12. The exciter stage 10 includes an exciter stator 14 connected to an AC power source 16 and an exciter rotor 18 disposed for rotary advancement by a local power source 19. The generator stage 12 includes a generator rotor 20, connected for common rotation with the exciter rotor 18, and a generator stator 22. The windings of the exciter rotor 18 and the generator rotor 20 are connected together, but wound in opposite directions. The generator stator 22 is connected to a load 23.

15

20

In operation, the exciter rotor 18 is rotated by the local power source 19 within the rotating magnetic field developed by the exciter stator 14. The induced signal frequency at the output of the exciter rotor 18 is equal to the summation of the angular rate of the local power source 19 plus the frequency of the AC power source 16. As the generator rotor 20 is rotated within the generator stator 22, the inverse connection to the exciter rotor 14 causes the angular rate produced by the local power source 19 to be subtracted out. The result being an induced voltage at the output of the generating stator 22 equal in rate to the frequency of the AC power source.

25

While the foregoing Nickoladze solution provides a theoretical output voltage where only the line frequency of the utility grid is produced, in practice, the manufacture of these devices is often fraught with difficulty for three-phase power applications due proper phase angle alignment between the exciter and generator stages and the windings. Often, due to the physical windings of the rotor and stator elements, phase angle alignment between the exciter and generator stages could not be achieved in the past. Moreover, some devices simply failed to perform altogether because the phase sequence of the windings was improper. These problems become even more pronounced when the exciter stage and generator stage are manufactured independently of one another.

35

Accordingly, there is a current need for a three-phase line synchronous generator that can be produced with proper phase angle alignment for three-phase power applications resulting in

1

a constant frequency and voltage output at variable shaft speeds. It is desirable that phase angle alignment be easily achieved even for exciter and generator components wound in opposite directions or with phases that start in different slots on the core with relation to the keyway.

5

#### SUMMARY OF THE INVENTION

10

15

An embodiment of the present invention is directed to a method and apparatus that satisfies this need. There is, therefore provided, according to a preferred embodiment, a line synchronous generator having an exciter stage with an exciter stator and an exciter rotor, and a generator stage with a generator stator and generator rotor. In one embodiment, the stators are wound with primary windings for connection to an AC power source and the rotors are wound with secondary windings. In an alternative embodiment, the rotors are wound with primary windings for connection to the AC power source and the stators are wound with secondary windings.

20

25

30

The proper phase angle alignment of the first, second and third phase windings of the secondary windings are determined by connecting the primary windings of the exciter and generator stages to the AC power source having a line voltage  $V_m$ , and connecting the first secondary phase winding of the exciter stage to the first secondary phase winding of the generator stage. Then, the voltage between the second secondary phase winding of the exciter stage and the second secondary phase winding of the generator stage is confirmed to be approximately  $2V_m$ , and the voltage between the third secondary phase winding of the exciter stage and the third secondary phase winding of the generator stage is confirmed to be approximately  $2V_m$ . Preferably, the voltage between the second secondary phase winding of the exciter stage and the third secondary phase winding of the generator stage is confirmed to be approximately  $\sqrt{3}V_m$ , and the voltage between the third secondary phase winding of the exciter stage and the second secondary phase winding of the generator stage is confirmed to be approximately  $\sqrt{3}V_m$ . Once these voltages are confirmed, the second secondary phase winding of the exciter stage is connected to the second secondary phase winding of the generator stage, and the third secondary phase winding of the exciter stage is connected to the third secondary phase winding of the generator stage.

35

In a preferred embodiment of a rotor primary machine, the line synchronous generator is configured with an exciter rotor disposed for rotary advancement by an external power source. The exciter rotor includes a pair of poles each having a winding for connecting across the AC power source. The exciter stator, mounted for rotation on an interior portion of the exciter stator, also has a pair of poles each having a winding. The generator rotor, mounted for common rotation with the exciter rotor, has a pair of poles each having a winding for connection across

1

the AC power source. The generator stator has an interior portion with the generator rotor rotationally mounted therein. The generator stator has a pair of poles each having a winding inversely connected to the corresponding windings on the exciter pole pair for canceling the electrical frequency induced by the of the rotation of the exciter and generator rotors.

5

An attractive feature of the described embodiments is that the line synchronous generator remains self-synchronizing despite variations in shaft speeds. Moreover, proper phase angle alignment can be readily achieved even for exciter and generator components independently manufactured with windings in opposite directions or with phases that start in different slots on the core with relation to the keyway. This economically viable solution to alternative power sources has a major potential for resolving the present energy shortage with minimum adverse ecological consequences.

10

15

It is understood that other embodiments of the present invention will become readily apparent to those skilled in the art from the following detailed description, wherein is shown and described only embodiments of the invention by way of illustration of the best modes contemplated for carrying out the invention. As will be realized, the invention is capable of other and different embodiments and its several details are capable of modification in various other respects, all without departing from the spirit and scope of the present invention. Accordingly, the drawings and detailed description are to be regarded as illustrative in nature and not as restrictive.

20

#### BRIEF DESCRIPTION OF THE DRAWINGS

25

These and other features, aspects, and advantages of the present invention will become better understood with regard to the following description, appended claims, and accompanying drawings where:

FIG. 1 is a simplified diagrammatic illustration of an induction generator described in U.S. Patents 4,701,691 and 4,229,689;

30

FIG. 2 is a simplified diagrammatic illustration of a three-phase stator primary line synchronous generator in accordance with a preferred embodiment of the present invention;

FIG. 3 is a simplified diagrammatic illustration of a three-phase rotor primary line synchronous generator in accordance with a preferred embodiment of the present invention;

FIG. 4 is a simplified diagrammatic illustration of a redundant line synchronous generator structure in accordance with a preferred embodiment of the present invention;

35

FIGS. 5A-5C are vector diagrams illustrating the proper phase relationships between the secondary windings of the line synchronous generator in accordance with a preferred embodiment of the present invention;

1

FIGS. 6A-6F are vector diagrams illustrating improper phase relationships between the secondary windings of the line synchronous generator in accordance with a preferred embodiment of the present invention;

5

FIG. 7A is a diagrammatic illustration showing the secondary windings of the line synchronous generator in accordance with a preferred embodiment of the present invention before test;

10

FIG. 7B is a diagrammatic illustration showing the secondary windings of the line synchronous generator in accordance with a preferred embodiment of the present invention when properly connected with renumbered terminals;

FIG. 8 is a diagrammatic illustration showing compensation circuitry connected between the secondary windings in accordance with a preferred embodiment of the present invention;

15

FIG. 9 is a graph illustrating the output power for various compensation circuits as a function of angular rotation of the rotors in accordance with a preferred embodiment of the present invention;

FIG. 10 is a graph illustrating the output power for phase angles between the exciter and generator stage as a function of angular rotation of the rotors in accordance with a preferred embodiment of the present invention; and

20

FIG. 11 is a vector diagram illustrating the proper phase relationships between the secondary windings of the line synchronous generator with a  $15^{\circ}$  phase angle error in accordance with a preferred embodiment of the present invention.

#### DETAILED DESCRIPTION

25

A preferred embodiment of the present invention is shown in FIG. 2. The three-phase line synchronous generator includes two stages, an exciter stage 24 and a generator stage 26. The exciter stage 24 includes an exciter stator 28 having three electromagnetic pole pairs. Each pole pair has a primary winding connected across a different phase of an AC power source 30. An exciter rotor 32, mounted for rotation within the interior of the exciter stator 28, also includes three electromagnetic pole pairs each wound with a secondary winding. The exciter rotor 32 is disposed for rotary advancement by a local power source 33.

30

The generator stage 26 includes a generator rotor 34 connected for common rotation with the exciter rotor 32 inside the interior of a generator stator 38. The generator rotor 34 also includes three electromagnetic pole pairs each wound with a secondary winding. The secondary windings of the generator rotor are inversely connected to the secondary windings of the exciter rotor 32 to effect electrical cancellation of the frequency induced by the angular rotation of the local power source. The generator stator 38 is connected to the AC power source 30.

35

1

In an alternative embodiment of the present invention, the rotors of the exciter and generator stages are connected to the AC power source, and the three-phase windings of the exciter and generator stators are connected for electrical cancellation. Turning to FIG. 3, an exciter rotor 52, disposed for rotary advancement by a local power source 53, has three electromagnetic pole pairs each with a primary winding connected across a different phase of the AC power source 54. The exciter stage 56 also includes an exciter stator 72 with three electromagnetic pole pairs wound with secondary windings.

5

10

Similarly, the generator stage 64 includes a generator stator 74 with three electromagnetic pole pairs wound with secondary windings. The secondary windings of the exciter stator 72 are inversely connected to the secondary windings of the generator stator 74 to effect electrical cancellation of the frequency induced by the angular rotation of the local power source. The generator rotor 75, connected for common rotation with the exciter rotor 52, is connected to the AC power source 54. For explanatory purposes only, the embodiments of the present invention will be described for a three-phase line synchronous generator configured as stator primary machine, i.e., stators connected to the AC power source. However, it will be understood by those skilled in the art that the present invention is not limited to stator primary machines, and that all described embodiments and test procedures are equally applicable to rotor primary machines, i.e., rotors connected to the AC power source.

15

20

As shown in FIG. 4 the line synchronous generator may be expanded to include redundant components. Specifically, a third redundant stage comprising a rotor 78 on the common shaft 80 and a stator 76 may be left unconnected. The terminals T001, T002 and T003 may then be connected in replacement for the terminals T1, T2 and T3 or T01, T02 and T03, in the event that the exciter or generator stage fails.

25

30

35

The operation of the generator is described with reference to FIG. 2. With stator primary machines, the exciter stator 28 is excited by the AC power source 30 which creates a revolving magnetic field at an angular rate equal to the frequency of the AC power source 30. The exciter rotor 32 is rotated by the local power source 33 within the rotating magnetic field developed by the exciter stator 28. The induced signal frequency at the output of the exciter rotor 32 is equal to the summation of the angular rate of the local power source 33 plus the frequency of the AC power source 30. As the generator rotor 34 is rotated within the generator stator 38, the inverse connection to the exciter rotor 32 causes the angular rate produced by the local power source 33 to be subtracted out. The result being an induced voltage at the output of the generating stator 38 equal in rate to the frequency of the AC power source. Thus, at any angular rate above synchronous speed for a multi-pole generator in accordance with an embodiment of the present

1

invention, the voltage output will have the same frequency as the source it is connected with. Below synchronous speed, power will be consumed rather than generated.

5 While this theoretical solution resolves the effects of shaft speed variations on the output frequency of a three-phase line synchronous generator, optimal output performance can only be achieved by the proper phasing alignment between the exciter and generator stages 24, 26. This connection is achieved by initially ensuring that the primary windings of the exciter stage has the same phase sequence as the primary windings of the generator stage, and then inversely  
10 connecting the secondary windings of the exciter and generator stages.

As a result of exciter and generator stages being manufactured independently of one another, it is important to determine the proper connection between the primaries to ensure the each stage of the line synchronous generator has the same phase sequence. This determination can be made in a number of ways. For example, with a stator primary machine, a small three  
15 phase motor may be driven from the stator windings with power applied to the rotor windings. The proper phasing sequence of the stator windings will occur when the motor is driven in the same direction of rotation from both the exciter stator winding and the generator stator winding. Another way to obtain the proper phase sequence is with a phase rotation meter, or with two lamps and an AC capacitor connected in wye in accordance with known test techniques in the  
20 art.

Once the proper phase sequence is established, the stator windings are connected to the corresponding phases of the AC power source. The proper phase angle between the rotor windings is then established by the interconnection process. To obtain electrical cancellation of the frequency induced by the angular rate of the rotor shaft, the rotor windings must be connected  
25 such that the voltage induced by angular rotation in each exciter rotor winding has an equal but opposite polarity than the voltage induced in the generator rotor winding to which it is connected.

Vector diagrams provide a useful mechanism for illustrating how the interconnections between the second windings can be ascertained. As shown in FIGS. 5 and 6, only three possible interconnections between the rotor windings results in a  $180^{\circ}$  phase shift between the each  
30 secondary winding connection as shown in FIGS. 5A-5C, each exciter rotor winding is shifted  $180^{\circ}$  with respect to its corresponding generator rotor winding. For example, consider FIG. 5B. The following phase angles between the connected terminals are easily ascertained:

$$\begin{aligned} T03 &= 0^{\circ} \text{ and } T3 = 180^{\circ}; \Delta 180^{\circ} \\ T01 &= 120^{\circ} \text{ and } T1 = 300^{\circ}; \Delta 180^{\circ}; \text{ and} \\ 35 \quad T02 &= 240^{\circ} \text{ and } T2 = 60^{\circ}; \Delta 180^{\circ}. \end{aligned}$$

The same phase relationships hold true for the secondary connections shown by the vector diagrams in FIGS. 5A and 5C.

1

In contrast, there are six other possible interconnections which will not effect electrical cancellation of the frequency induced by the angular rotation of the rotors. These six incorrect connections are shown by the vector diagrams in FIGS. 6A-6F. As shown in each of these diagrams, the voltages in each pair of connections between the exciter rotor and the generator rotor not only has the same voltage, but has the same phase. Referring to FIG. 6A, by way of example, this relationship is easily shown:

$$\begin{aligned} T01 &= 300^{\circ} \text{ and } T1 = 300^{\circ}; \Delta \ 0^{\circ} \\ T02 &= 60^{\circ} \text{ and } T2 = 60^{\circ}; \Delta \ 0^{\circ}; \text{ and} \\ T03 &= 180^{\circ} \text{ and } T3 = 180^{\circ}; \Delta \ 0^{\circ}. \end{aligned}$$

These vector diagrams are also useful for establishing test parameters for determining the proper interconnections between the rotor windings during the manufacturing process. Common to each of vector diagram of FIGS. 5A-5C, with one exciter rotor winding of the three-phase windings connected to one generator rotor winding, the voltages between the remaining open windings will consist of two pairs at two times the line voltage ( $2V_m$ ) and two pairs at  $\sqrt{3}$  times the line voltage ( $\sqrt{3} V_m$ ) which is proven by the geometric relationship between the phases. For example, the voltages induced in the open windings in FIG. 5B are:

$$\begin{aligned} T2 \text{ to } T02 &= 2V_m \\ T3 \text{ to } T03 &= 2V_m \\ T2 \text{ to } T03 &= \sqrt{3} V_m \\ T3 \text{ to } T02 &= \sqrt{3} V_m \end{aligned}$$

Since vectors have a designated length and direction in space, these results can be verified with an ordinary ruler.

The vector diagrams can be confirmed mathematically. Classic electrical theory holds that when a voltage is applied to a primary winding of an induction generator, a voltage will be induced into the open circuit secondary winding. A wye-connected three-phase winding has each phase displaced by  $120^{\circ}$ . The induced voltage at the open circuit secondary terminals will be balanced. For the phasing test, a jumper wire interconnects one terminal of each secondary winding. In Figure 5B, this is terminal T1 and terminal T01. With a voltage applied to the primary, the remaining open circuit secondary voltages are measured. For Figure 5A, this would be

$$\begin{aligned} T2 \text{ to } T02 \\ T3 \text{ to } T03 \\ T2 \text{ to } T03 \\ T3 \text{ to } T02 \end{aligned}$$

1

As can readily be seen from FIG. 5A, the secondary voltage between T2-T01 is the line voltage. Also, the voltage between T1-T02 is the line voltage. Therefore, the voltage between T2-T02 will be twice the line voltage. The same holds true for T3-T03.

5

The voltage across T2-T03 is the resultant of an oblique triangle defined by sides T1-T03, T01-T2, and T2-T03. When properly aligned, classic three-phase electrical theory identifies the angles as shown on Figure 5B. The resultant voltage between T2-T03 will be:

10

$$V_{2-03} = (V_{2-03}) \frac{\sin \angle B}{\sin \angle A}$$

For proper alignment:

15

$$\begin{aligned} V_{2-03} &= (V_{2-03}) \left( \frac{\sin 120^\circ}{\sin 30^\circ} \right) \\ &= (V_{2-03}) \left( \frac{0.866}{0.5} \right) \\ &= (V_{2-03}) (1.73) \end{aligned}$$

20

The same holds true for the voltage between T3-T02. Therefore, with proper alignment, the voltage will be one pair of terminals at two times line voltage and one pair of terminals at  $\sqrt{3}$  times the line voltage.

25

With the knowledge gleaned from these vector diagrams, a methodology of interconnecting the rotor windings can be ascertained which significantly reduces the manufacturing cost while increasing product yield. Specifically, the method for determining the proper interconnections in a stator primary machine requires the connection of a pair of rotor windings and then finding two remaining pairs of substantially identical voltages between the rotor windings.

30

Turning to FIG. 7A, the secondary windings are shown ready for test. The exciter and generator stators are connected to an AC power source. The line voltages induced should be equal if the two sets of rotor windings are alike: turns, pitch, wire size, connection, etc. In this example, the interphase voltage is 90 volts. The connection could be wye (star) as shown, or

35

1

delta, or one of each. In order to obtain test readings, a terminal from each rotor winding is joined by a connecting jumper.

5 Either the primary or secondary could be the rotor or stator, but they must be the same part. Thus, if one half of the synchronous generator is configured as a rotor primary machine, then the other half of the synchronous generator must also be configured as a rotor primary machine.

10 As defined by the vector diagrams of FIGS. 5 and 6, two pairs of substantially identical voltages must be found. With a line voltage of 90 volts, the following values must be obtained during test:

$$2(90) = 180 \text{ volts for one voltage pair; and}$$

$$\sqrt{3}(90) = 156 \text{ volts for the other voltage pair.}$$

15 To perform the test, a jumper wire is placed across a terminal for each rotor winding. In this example, a jumper wire is first placed across T1 and T01 and the following voltages are obtained by test:

$$T2 - T02 = 156 \text{ volts}$$

$$T2 - T03 = 90 \text{ volts}$$

$$T3 - T02 = 180 \text{ volts}$$

$$20 \quad T3 - T03 = 156 \text{ volts.}$$

These measured voltages are consistent with FIGS. 6A-6F showing the improper interconnection of rotor windings.

The jumper wire is then removed and placed across another terminal pair. In this example, the jumper wire is next placed across T2 and T01, and the following voltage are obtained by test:

$$25 \quad T1 - T02 = 156 \text{ volts}$$

$$T1 - T03 = 180 \text{ volts}$$

$$T3 - T02 = 180 \text{ volts}$$

$$T3 - T03 = 156 \text{ volts.}$$

30 This result is consistent with FIGS. 5A-5C and confirms the proper interconnection of the rotor windings. From the vector diagrams 5A-5C it can be seen that the rotor windings having a voltage of  $2V_m$ , or 180 volts should be connected together. The proper interconnections of the rotor windings are shown in FIG. 7B with T1 connected to T03 and T3 connected to T02. Preferrably, the terminals should be renumbered.

35 Once the proper phase angle between the rotor windings is established, electrical compensation may then be inserted between each pair of the three-phase windings. Specifically, resistors and capacitors can be inserted between the respective windings to expand the dynamic operating range of the device without the necessity of continual phase angle adjustments between

1

the exciter and generator stages. Alternatively, electrical compensation may be inserted in the primary windings of the stators.

5 Turning to FIG. 8, the effect of compensation resistance inserted between the rotor windings results in an expanded operating range allowing higher operating speed. In this example, compensation networks 76, 78 and 80 effect the winding interconnection described above. Network 76 includes a resistor 82, in parallel with a capacitor 84, network 78 comprises a resistor 88 in parallel connection with a capacitor 90, and network 80 comprises a resistor 94,  
10 in parallel connection with a capacitor 96. It has been found that by increasing the resistance of resistors 82, 88, and 94 from approximately 0 ohms to about 5.8 ohms, the dynamic range expressed in ratio of both the power factor and efficiency are substantially increased.

FIG. 9 shows the expanded range of the device using utilizing resistors to achieve the desired results for tailored applications. The output curve is shown for a 15 kW, 4 pole, 60 Hz  
15 three-phase line synchronizing generator.

Another important parameter for optimizing performance of the three-phase line synchronous generator is the phase angle between the generator and exciter stages. In a preferred embodiment of the present invention, the angular position of the exciter stator, exciter generator, generator rotor or generator stator can be advanced or retarded to optimize performance. Optimal  
20 loading is a function of the exciter phase angle and rotor rpm. As the RPM increases substantially above "synchronous speed", the phase angle range necessary to meet maximum generator load narrows significantly. Thus, through manipulation of the phase angle of the exciter stage relative to the generator stage, complete control over loading is achieved. A responsive and accurate device must be employed to adequately provide phase angle optimization  
25 when variable speed prime movers are used.

FIG. 10 illustrates the output power of a 6 pole, 25 kW, 480 volt, 60 Hz stator primary machine coupled to a 75 horsepower DC variable speed motor at different phase angles. The power output is shown at four different phase angles between the exciter and generator magnetic field.

30 In a preferred embodiment, the generator stator field is tapped and compared with the AC source frequency by a control mechanism to provide a phase error signal to a servo motor. This servo motor positions the exciter stator to optimize generator loading, a function of the phase difference that results from changes in shaft speed. The accuracy and response of the servo motor and its control mechanism are critical to optimize generator loading. Because servo motor  
35 control technology is sufficiently advanced, accurate exciter induction compensation can be provided in virtually all electrical generation applications.

1

Alternatively, the phase angle may be set during the interconnection process of the rotor windings. Turning to FIG. 11, a vector diagram is shown representing the phase relationships of the rotor windings with proper interconnection to effect electrical cancellation but with a 15<sup>0</sup> phase angle misalignment between the exciter and generator stages. The test represented in FIG. 10 is performed with T1 connected to T01. The following test results are obtained:

5  
10  
15  
20

T2 to T02 = 178 volts  
T2 to T03 = 143 volts  
T3 to T02 = 166 volts  
T3 to T03 = 178 volts

The voltage between terminals T2 - T02 and T3 - T03 are each 178 volts, which is close enough to 180 volts to satisfy one of the required pairs. However, the voltages between the remaining terminals are not close enough to the 156 volts to satisfy the second required pair. However, if the voltages are averaged, the result is 155 volts which is close to the desired voltage. This indicates improper phase angle between the exciter stage and the generator stage. In this case, either the exciter stator, the exciter rotor, the generator stator or the generator rotor can be physically rotated on its axis until the voltages between T2 and T03 and the voltages between T3 and T02 each read 155 volts. In this case, from the vector diagram of FIG. 8, it can be seen that a 15<sup>0</sup> electrical phase shift will result in optimal performance.

Alternatively, phase angle correction can be performed by altering the windings of either the exciter rotor, exciter stator, generator rotor or the generator stator. In other words, the optimum phase angle can be achieved without physically shifting the rotors or stators, but winding them offset. If slots on the generator portion are numbered 1 to 36, for example, we start the generator group in slot 1, and the exciter's group is started in slot 2 or 3, to get the phase angle as desired.

The physical angular displacement is determined by the number of poles. Specifically, the angular displacement is:

30

$$X = \frac{360^\circ}{\text{Phases} \times \text{Poles}}$$

For a four (4) pole three-phase system this angle is:

35

$$X = \frac{360^\circ}{(3) (4)} = 20^\circ$$

1

Therefore, one an angular displacement of  $20^\circ$  is required. This may be accomplished by displacing the winding of two fixed cores only if the slot count allows the requisite angle to be met. For example, a 36 slot core with a two slot displacement would result in  $20^\circ$  and is acceptable for four (4) pole three-phase system. But a 48 slot core does not result in any combination of  $20^\circ$ , and therefore, phase angle alignment could not be obtained by core displacement.

The described embodiments provide an important solution that allows the rotational speed to vary substantially over traditional machinery limits while remaining self-synchronizing. The active controls are simplified to those necessary for safety purposes. The machinery speed maximum limits may be enhanced with simple active control of passive devices. This shows the versatility of the inventor, an inherently acceptable speed range which may be extended by addition of simple passive devices. Thus, any local power source which allows for a minimum speed and exceeds the parasitic losses of the device may be effectively used to supply the utility grid. Such adaptation of local alternative power sources has a major potential for resolving the present energy shortage with minimum adverse ecological consequences.

It is apparent from the foregoing that the present invention satisfies an immediate need for a three-phase line synchronous generator with proper phasing having a constant frequency and voltage output at variable shaft speeds. This three-phase line synchronous generator may be embodied in other specific forms and can be used with a variety of fuel sources, such as windmills, wind turbines, water wheels, water turbines, internal combustion engines, solar powered engines, steam turbine, without departing from the spirit or essential attributes of the present invention. It is therefore desired that the described embodiments be considered in all respects as illustrative and not restrictive, reference being made to the appended claims rather than the foregoing description to indicate the scope of the invention.

30

35

1

## WHAT IS CLAIMED IS:

5           1.     A method for determining the proper phase alignment of a three-phase line synchronous generator, said line synchronous generator comprising an exciter stage having an exciter stator and an exciter rotor, one of said exciter stator and exciter rotor having a primary winding and the other one of said exciter stator and exciter rotor having first, second and third secondary phase windings, and a generator stage having a generator rotor and a generator stator, one of said generator stator and generator rotor having a primary winding and the other one of said generator stator and generator rotor having first, second and third secondary phase windings, the method comprising the steps of:

10

          connecting the primary windings of the exciter and generator stages to a three-phase AC power source, said AC power source having a line voltage equal to  $V_m$ ;

15

          connecting the first secondary phase winding of the exciter stage to the first secondary phase winding of the generator stage;

          confirming a voltage between the second secondary phase winding of the exciter stage and the second secondary phase winding of the generator stage equal to approximately  $2V_m$ ;

20

          confirming a voltage between the third secondary phase winding of the exciter stage and the third secondary phase winding of the generator stage equal to approximately  $2V_m$ ; and

25

          connecting the second secondary phase winding of the exciter stage to the second secondary phase winding of the generator stage;

          connecting the third secondary phase winding of the exciter stage to the third secondary phase winding of the generator stage.

30

2.     The method of claim 1 further comprising the steps of confirming a voltage between the second secondary phase winding of the exciter stage and the third secondary phase winding of the generator stage equal to approximately  $\sqrt{3}V_m$ , and confirming a voltage between the third secondary phase winding of the exciter stage and the second secondary phase winding of the generator stage equal to approximately  $\sqrt{3}V_m$ .

35

3.     The method of claim 1 wherein the secondary windings of the exciter stage are wound on the exciter rotor, and the secondary windings of the generator stage are wound on the generator rotor.

35

1

4. The method of claim 1 wherein the secondary windings of the exciter stage are wound on the exciter stator, and the secondary windings of the generator stage are wound on the generator stator.

5

10

5. The method of claim 1 further comprising the step of rotating one of said exciter stator, exciter rotor, generator stator and generator rotor on its axis before confirming the voltage between the second secondary phase winding of the exciter stage and the second secondary phase winding of the generator stage and confirming the voltage between the third secondary phase winding of the exciter stage and the third secondary phase winding of the generator stage.

15

6. The method of claim 1 further comprising the step of confirming the same phase sequence in the primary windings of the exciter and generator stages.

20

7. A line synchronous generator, comprising:  
an exciter rotor, disposed for rotary advancement by an external power source, comprising a pair of poles each having a winding for connecting across an AC power source;  
an exciter stator having a pair of poles each having a winding, said exciter rotor being mounted for rotation on an interior portion of the exciter stator;  
a generator rotor mounted for common rotation with the exciter rotor, said generator rotor having a pair of poles each having a winding for connection across the AC power source; and  
a generator stator having an interior portion with the generator rotor rotationally mounted therein, said generator stator having a pair of poles each having a winding inversely connected to the corresponding windings on the exciter pole pair for canceling an electrical frequency induced by the of the rotation of the exciter and generator rotors.

25

30

8. The line synchronous generator of claim 7 wherein each of said exciter and generator rotors comprise three pairs of poles with a three-phase winding for connection to a three-phase AC power source, and each of said exciter and generator stators comprise three pairs of poles with a three-phase winding, said three-phase winding of the exciter stator being inversely connected to said three-phase winding of the generator stator for canceling the electrical frequency induced by the of the rotation of the exciter and generator rotors.

35

9. The line synchronous generator of claim 7 further comprising a redundant rotor connected for common rotation with the exciter and stator rotors, and a redundant stator having an interior portion with the redundant rotor rotationally mounted therein, said redundant stator

1

having a pair of poles each having a winding adapted for inverse connection to one of said exciter stator and generator stator.

5

10

15

20

25

30

35

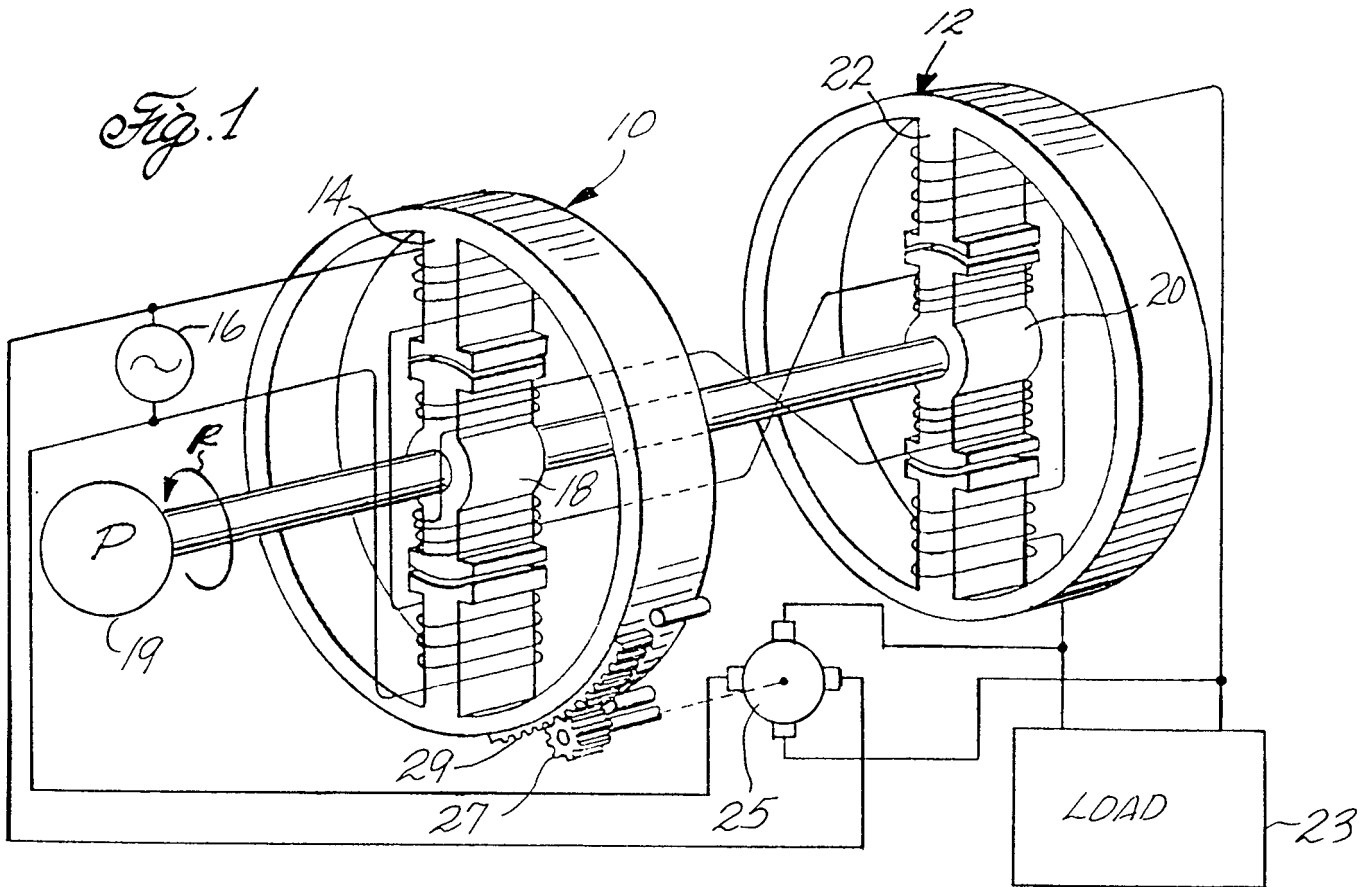

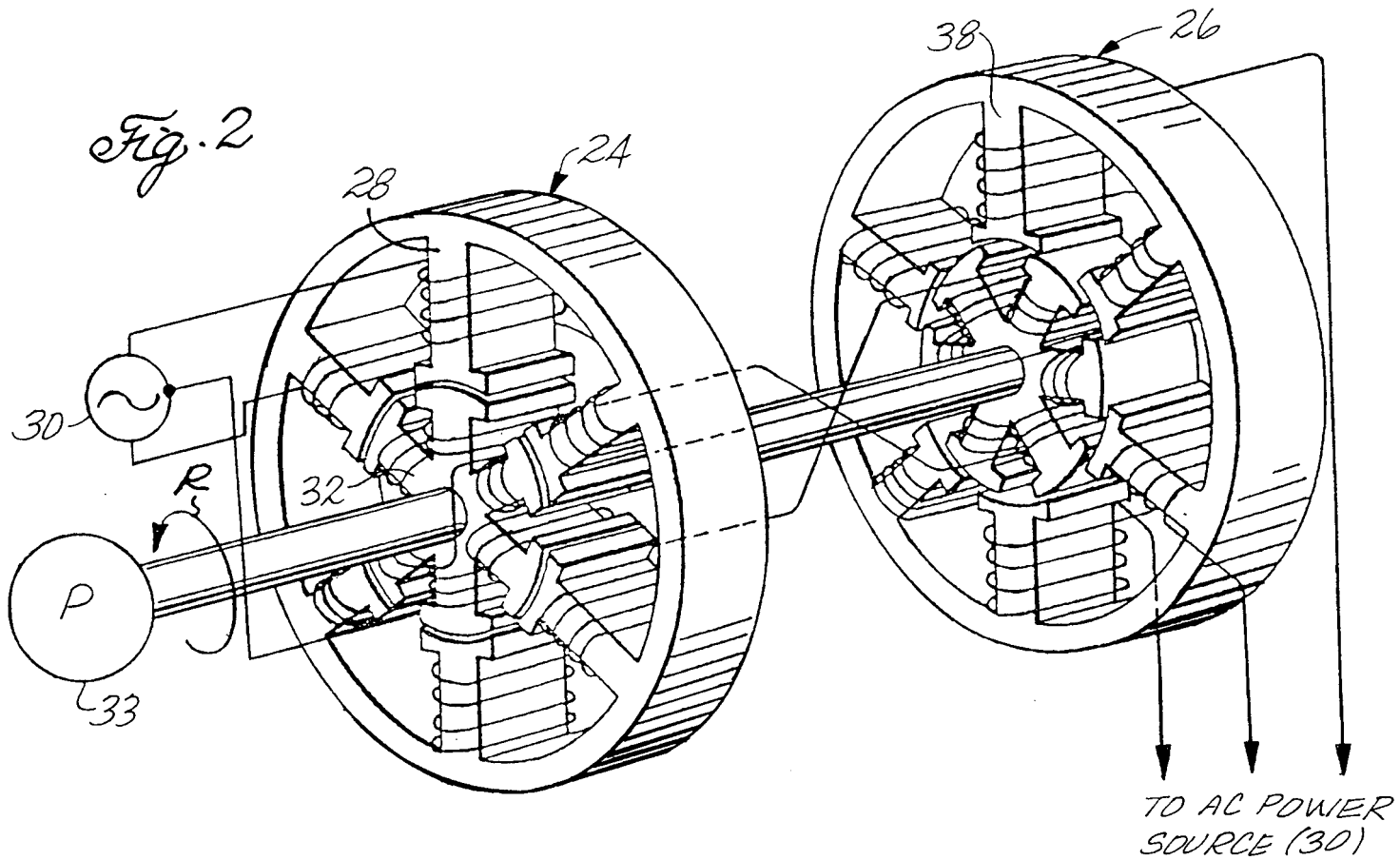

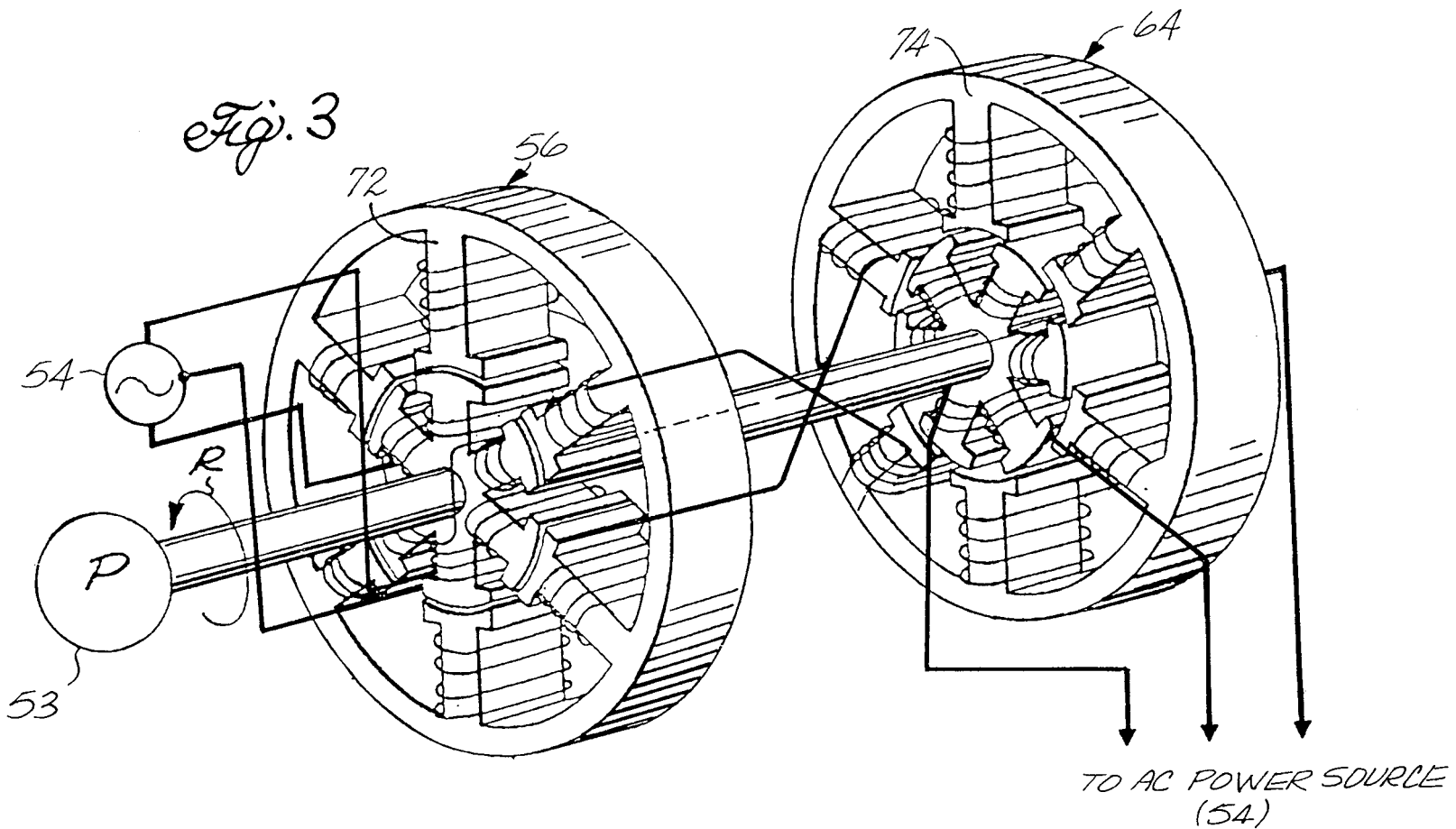
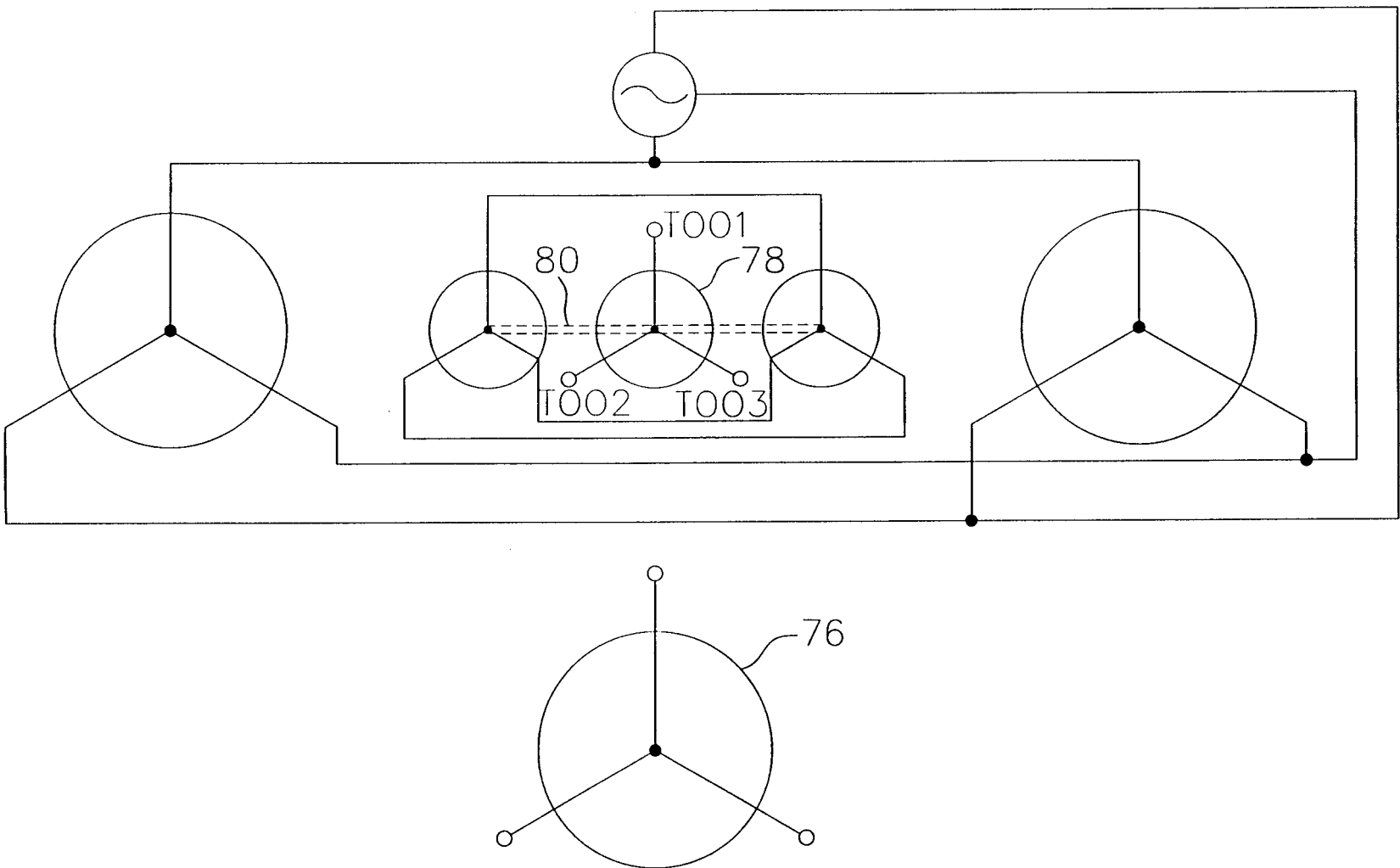
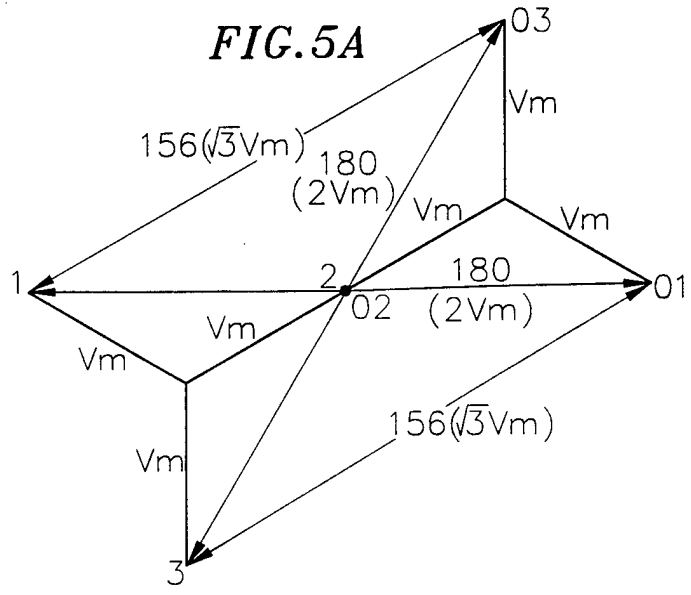

FIG. 4



**FIG. 5A**



**FIG. 5B**

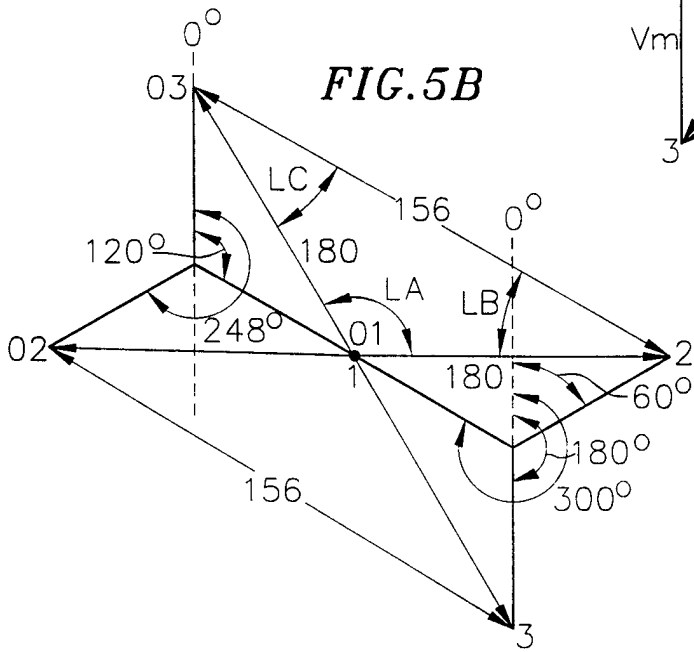

**FIG. 5C**

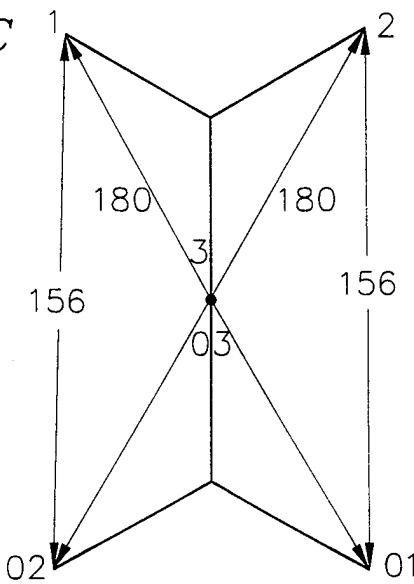

**FIG. 6A**

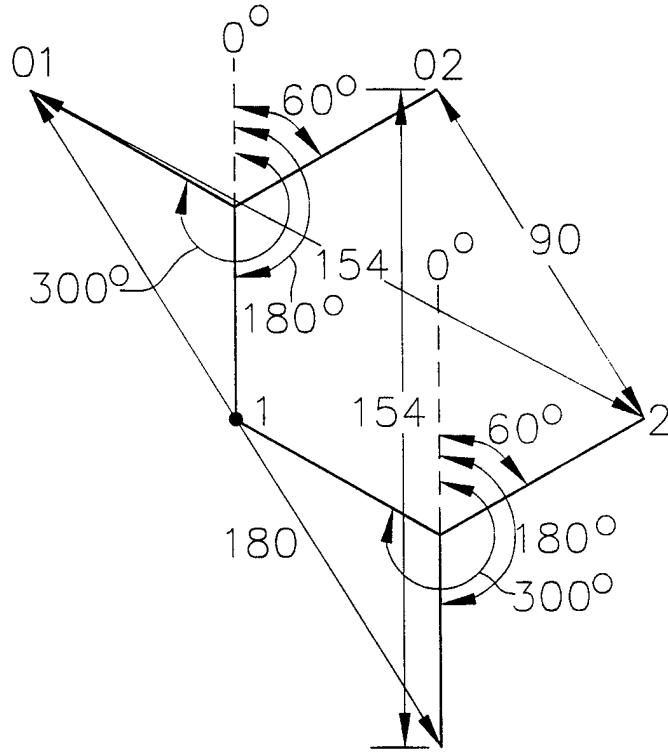

**FIG. 6B**

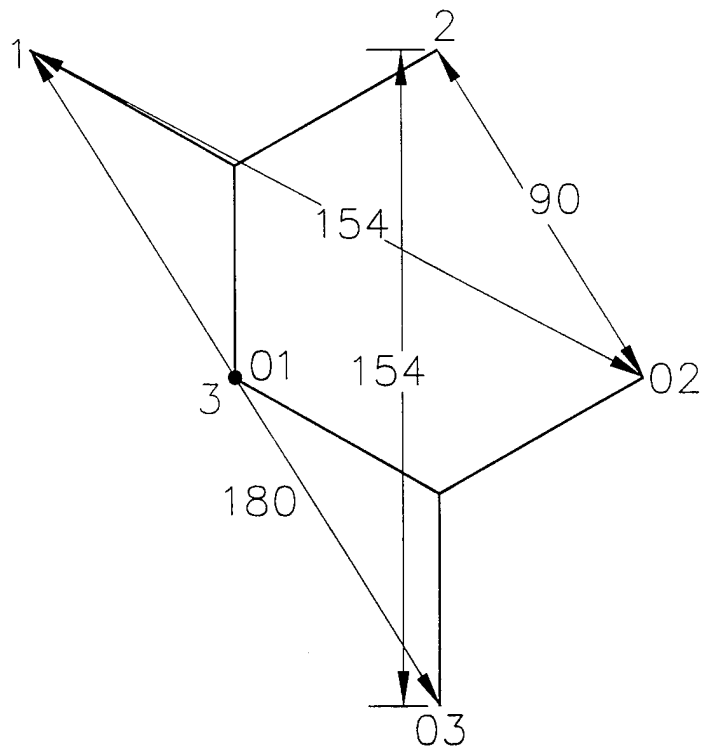

*FIG. 6C*

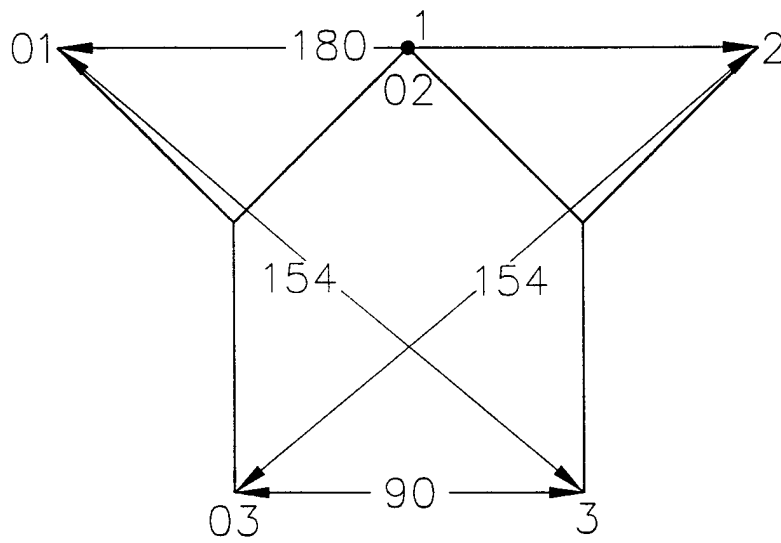

*FIG. 6D*

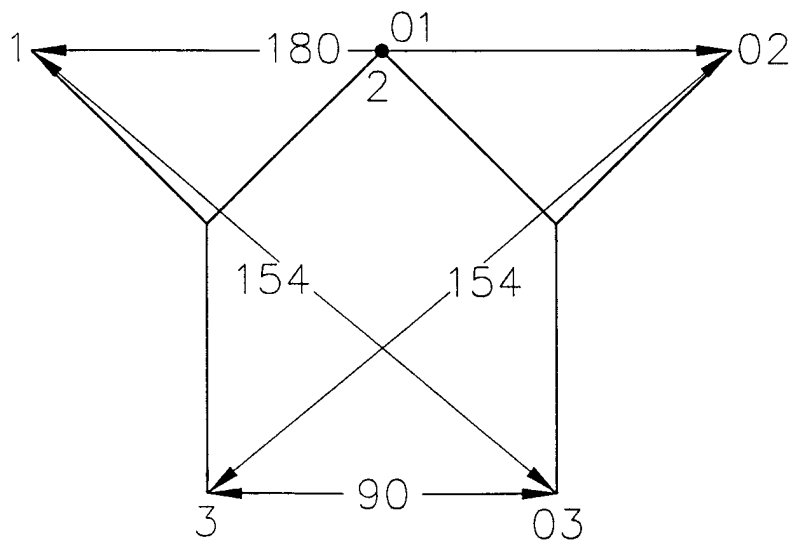

**FIG. 6E**

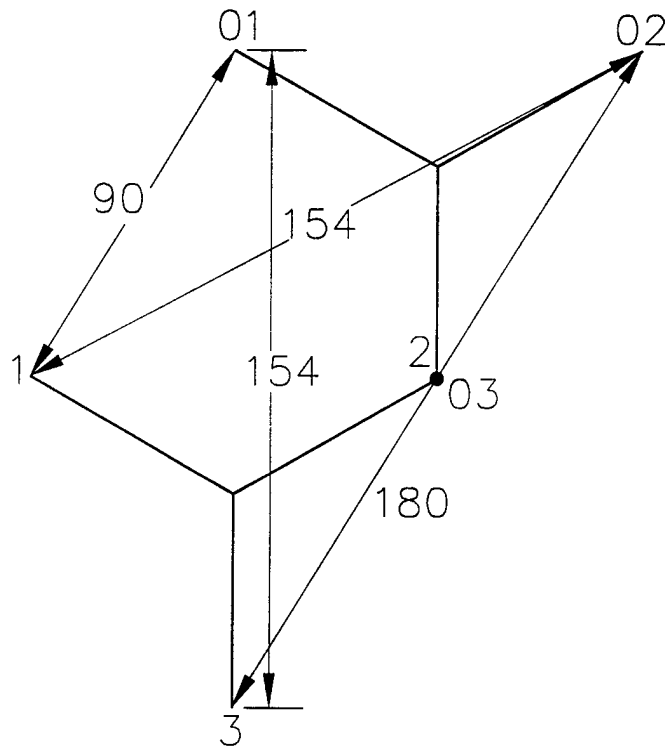

**FIG. 6F**

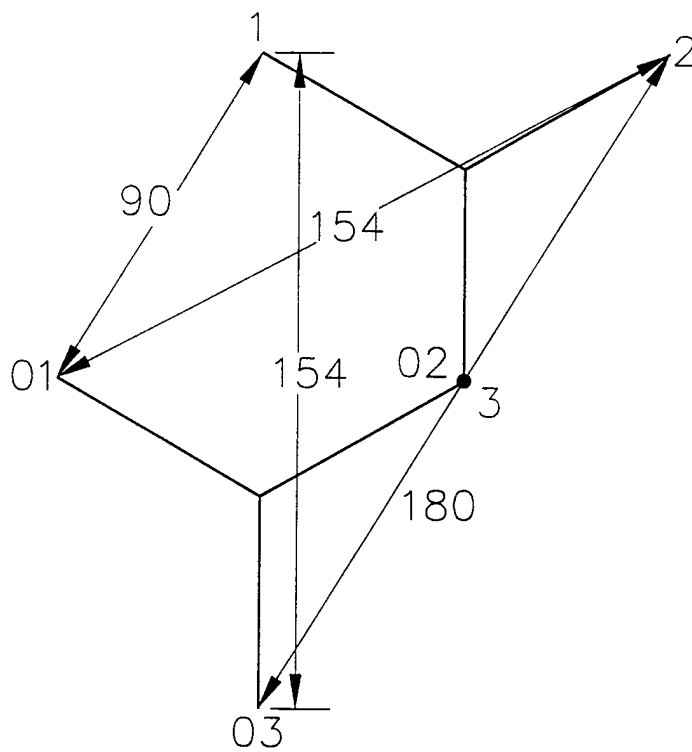

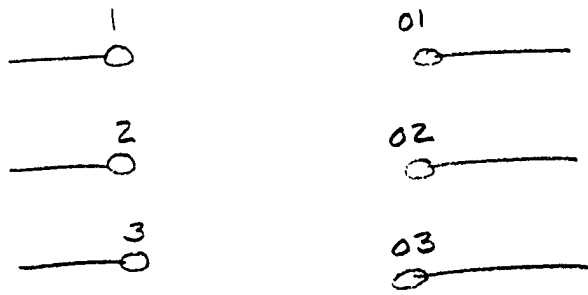

FIG. 7A

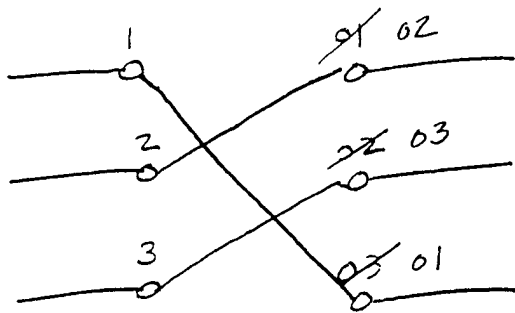

FIG. 7B

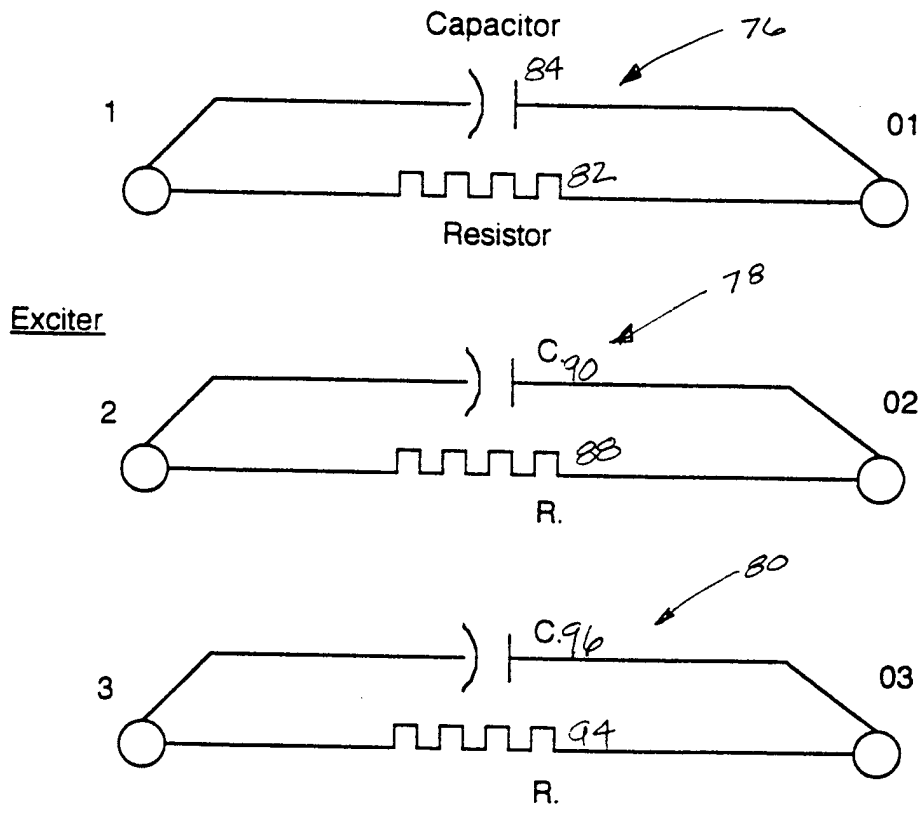

FIG. 8

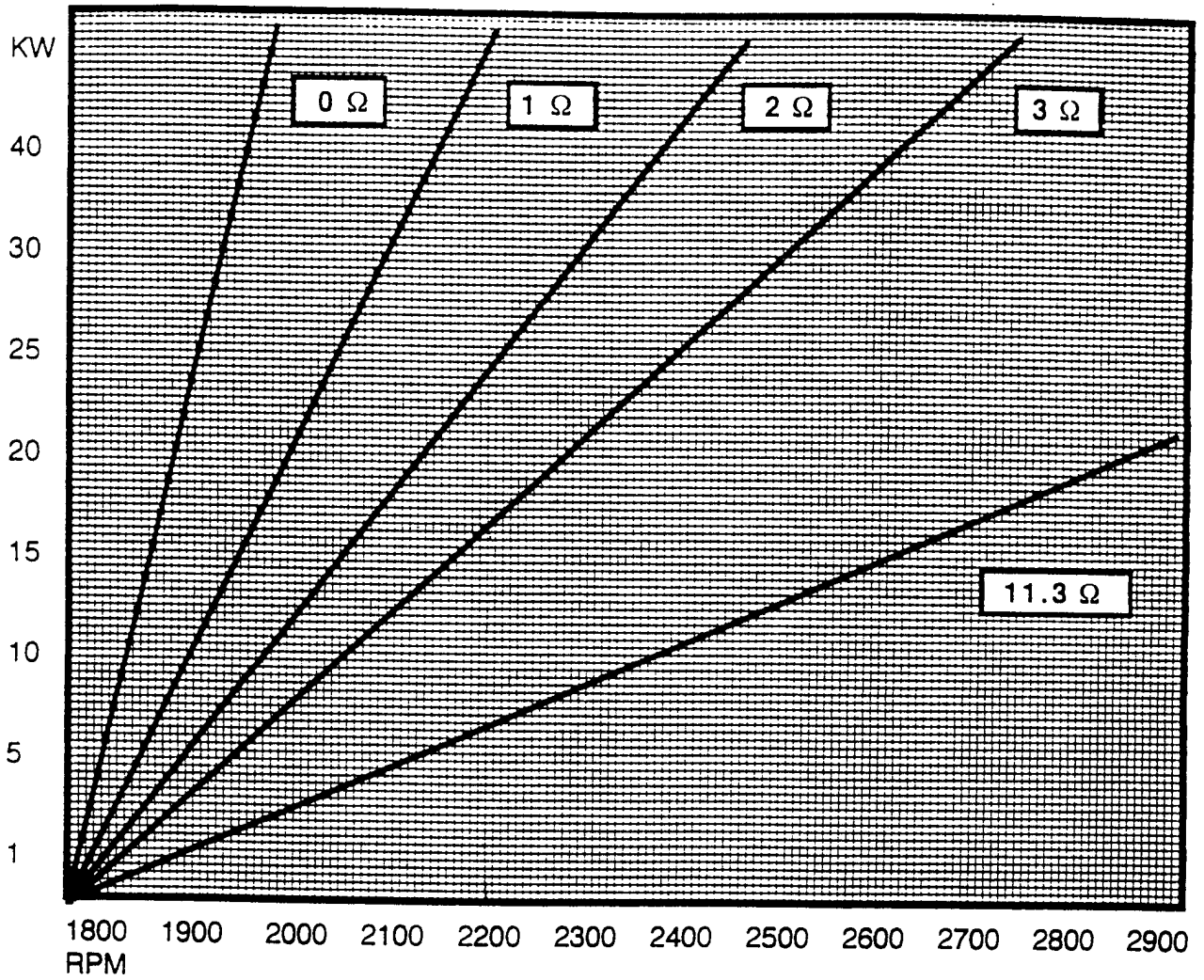

FIG. 9

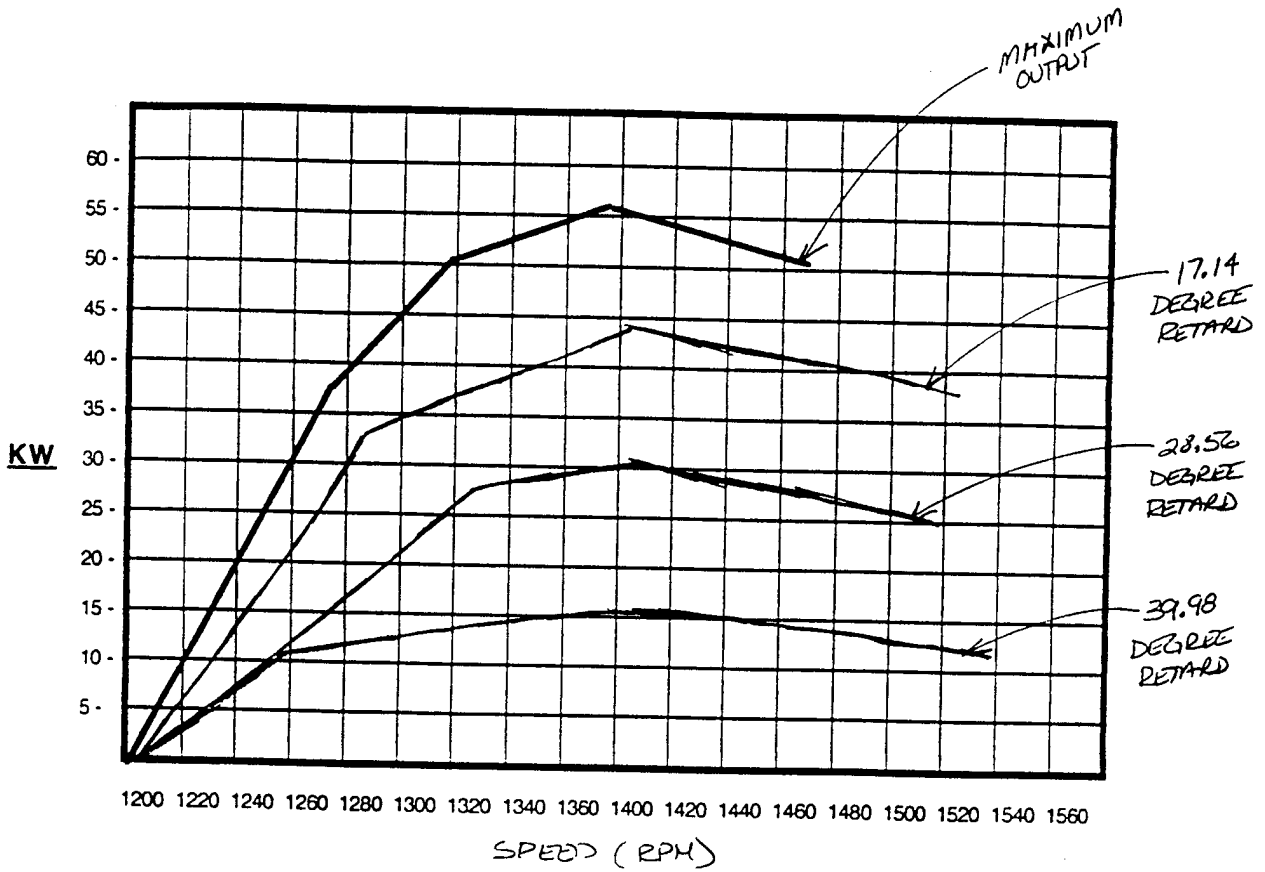

FIG. 10

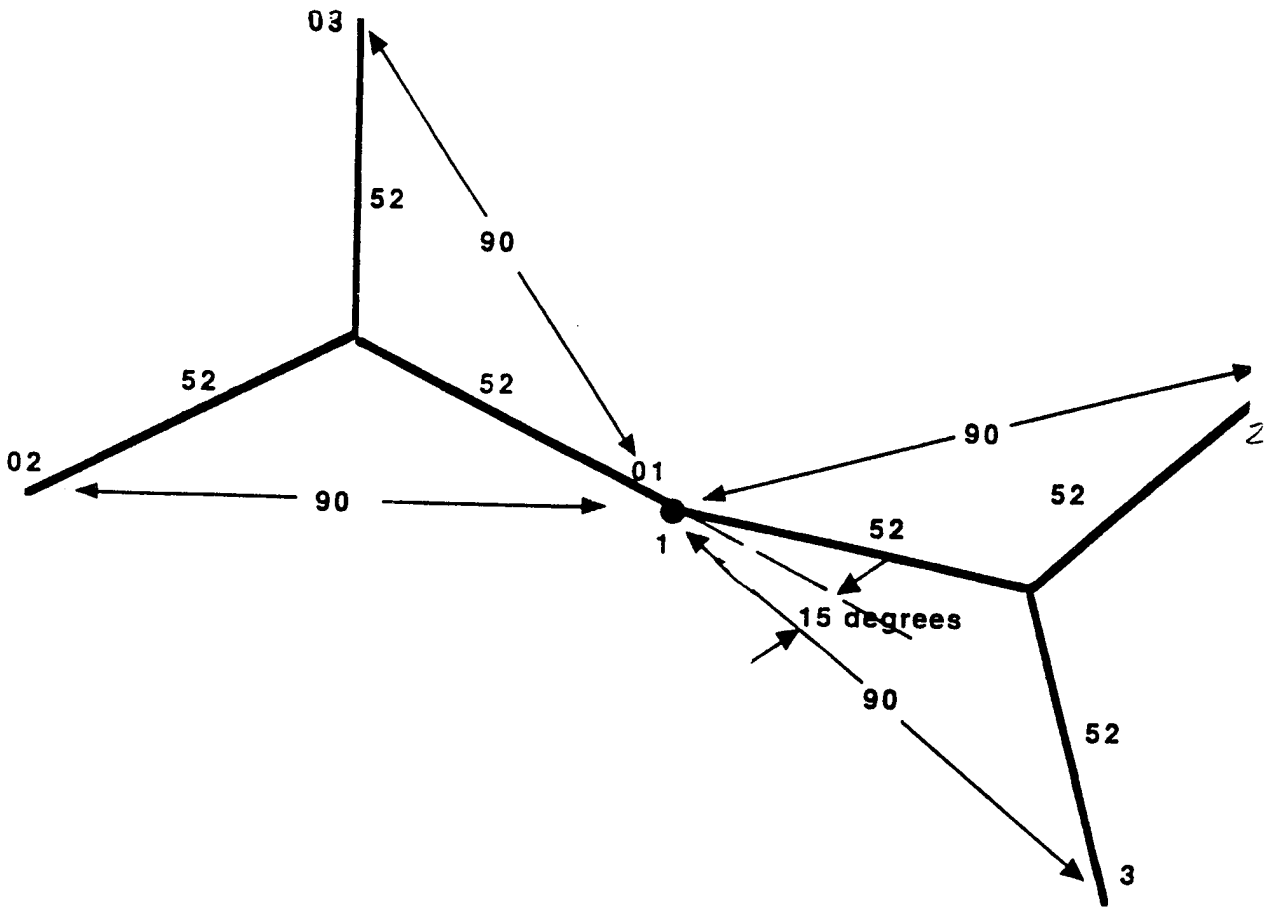

FIG. 11

INTERNATIONAL SEARCH REPORT

International application No.  
PCT/US98/02651

**A. CLASSIFICATION OF SUBJECT MATTER**  
 IPC(6) :H02P 9/00, H02K 17/10  
 US CL :322/32, 310/179  
 According to International Patent Classification (IPC) or to both national classification and IPC

**B. FIELDS SEARCHED**  
 Minimum documentation searched (classification system followed by classification symbols)  
 U.S. : 322/32, 310/179

Documentation searched other than minimum documentation to the extent that such documents are included in the fields searched

Electronic data base consulted during the international search (name of data base and, where practicable, search terms used)  
 APS, IS&R, MAYA

**C. DOCUMENTS CONSIDERED TO BE RELEVANT**

Category*	Citation of document, with indication, where appropriate, of the relevant passages	Relevant to claim No.
A	US 5,587,643 A [HELLER] December 24, 1996 (12.24.96)	1-6
Y	US 5,525,894 A [HELLER] June 11, 1996 (06.11.96), see col.1, lines 13-15	1-6
Y	US 4,701,691 A [NICKOLADZE] October 20, 1997 (10.20.97), see drawings	1-6
A	US 4,229,689 A [Nickoladze] October 21, 1980 (10.21.80), see abstract	7-9
A	US 5,254,894 A [Satake et al.] October 19, 1993 (10.19.93)	1-6
A	US 4,472,673 A [Miller] September 18, 1984 (9.18.84)	1-6

Further documents are listed in the continuation of Box C.  See patent family annex.

* Special categories of cited documents:	"T"	later document published after the international filing date or priority date and not in conflict with the application but cited to understand the principle or theory underlying the invention
"A" document defining the general state of the art which is not considered to be of particular relevance	"X"	document of particular relevance; the claimed invention cannot be considered novel or cannot be considered to involve an inventive step when the document is taken alone
"E" earlier document published on or after the international filing date	"Y"	document of particular relevance; the claimed invention cannot be considered to involve an inventive step when the document is combined with one or more other such documents, such combination being obvious to a person skilled in the art
"L" document which may throw doubts on priority claim(s) or which is cited to establish the publication date of another citation or other special reason (as specified)	"&"	document member of the same patent family
"O" document referring to an oral disclosure, use, exhibition or other means		
"P" document published prior to the international filing date but later than the priority date claimed		

Date of the actual completion of the international search 11 MAY 1998	Date of mailing of the international search report 30 JUL 1998
--	---

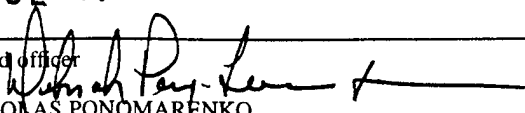
Name and mailing address of the ISA/US Commissioner of Patents and Trademarks Box PCT Washington, D.C. 20231 Facsimile No. (703) 305-3230	Authorized officer  NICHOLAS PONOMARENKO Telephone No. (703) 308-1776
---	--

## INTERNATIONAL SEARCH REPORT

International application No.  
PCT/US98/02651

C (Continuation). DOCUMENTS CONSIDERED TO BE RELEVANT		
Category*	Citation of document, with indication, where appropriate, of the relevant passages	Relevant to claim No.
A	US 4,305,001 A [Vamaraju et al.] December 08, 1981 (12.08.81)	1-6

INTERNATIONAL SEARCH REPORT

International application No.  
PCT/US98/02651

**Box I Observations where certain claims were found unsearchable (Continuation of item 1 of first sheet)**

This international report has not been established in respect of certain claims under Article 17(2)(a) for the following reasons:

- 1.  Claims Nos.:  
because they relate to subject matter not required to be searched by this Authority, namely:
  
- 2.  Claims Nos.:  
because they relate to parts of the international application that do not comply with the prescribed requirements to such an extent that no meaningful international search can be carried out, specifically:
  
- 3.  Claims Nos.:  
because they are dependent claims and are not drafted in accordance with the second and third sentences of Rule 6.4(a).

**Box II Observations where unity of invention is lacking (Continuation of item 2 of first sheet)**

This International Searching Authority found multiple inventions in this international application, as follows:

Please See Extra Sheet.

- 1.  As all required additional search fees were timely paid by the applicant, this international search report covers all searchable claims.
- 2.  As all searchable claims could be searched without effort justifying an additional fee, this Authority did not invite payment of any additional fee.
- 3.  As only some of the required additional search fees were timely paid by the applicant, this international search report covers only those claims for which fees were paid, specifically claims Nos.:
  
- 4.  No required additional search fees were timely paid by the applicant. Consequently, this international search report is restricted to the invention first mentioned in the claims; it is covered by claims Nos.:

Remark on Protest

- The additional search fees were accompanied by the applicant's protest.
- No protest accompanied the payment of additional search fees.

## INTERNATIONAL SEARCH REPORT

International application No.  
PCT/US98/02651

### BOX II. OBSERVATIONS WHERE UNITY OF INVENTION WAS LACKING

This ISA found multiple inventions as follows:

This application contains the following inventions or groups of inventions which are not so linked as to form a single inventive concept under PCT Rule 13.1. In order for all inventions to be searched, the appropriate additional search fees must be paid.

Group I, claim(s) 1-6, drawn to method for determining phase alignment classified in Class 322.

Group II, claim(s) 7-9, drawn to synchronopus generator structure classified in Class 310.

The inventions listed as Groups I and II do not relate to a single inventive concept under PCT Rule 13.1 because, under PCT Rule 13.2, they lack the same or corresponding special technical features for the following reasons: inventions have different classifications.