

(19) World Intellectual Property Organization
International Bureau



(43) International Publication Date
9 July 2009 (09.07.2009)

PCT

(10) International Publication Number
WO 2009/083028 A1

(51) International Patent Classification:
G08G 1/01 (2006.01)

(74) Agents: MACCALLI, Marco et al.; c/o Maccalli & Pezzoli S.r.l., Via Settembrini, 40, I-20124 Milano (IT).

(21) International Application Number:
PCT/EP2007/064580

(81) Designated States (unless otherwise indicated, for every kind of national protection available): AE, AG, AL, AM, AO, AT, AU, AZ, BA, BB, BG, BH, BR, BW, BY, BZ, CA, CH, CN, CO, CR, CU, CZ, DE, DK, DM, DO, DZ, EC, EE, EG, ES, FI, GB, GD, GE, GH, GM, GT, HN, HR, HU, ID, IL, IN, IS, JP, KE, KG, KM, KN, KP, KR, KZ, LA, LC, LK, LR, LS, LT, LU, LY, MA, MD, ME, MG, MK, MN, MW, MX, MY, MZ, NA, NG, NI, NO, NZ, OM, PG, PH, PL, PT, RO, RS, RU, SC, SD, SE, SG, SK, SL, SM, SV, SY, TJ, TM, TN, TR, TT, TZ, UA, UG, US, UZ, VC, VN, ZA, ZM, ZW.

(22) International Filing Date:
27 December 2007 (27.12.2007)

(25) Filing Language: English

(26) Publication Language: English

(71) Applicant (for all designated States except US): TELECOM ITALIA S.p.A. [IT/IT]; Piazza degli Affari, 2, I-20123 Milano (IT).

(84) Designated States (unless otherwise indicated, for every kind of regional protection available): ARIPO (BW, GH, GM, KE, LS, MW, MZ, NA, SD, SL, SZ, TZ, UG, ZM, ZW), Eurasian (AM, AZ, BY, KG, KZ, MD, RU, TJ, TM), European (AT, BE, BG, CH, CY, CZ, DE, DK, EE, ES, FI, FR, GB, GR, HU, IE, IS, IT, LT, LU, LV, MC, MT, NL, PL, PT, RO, SE, SI, SK, TR), OAPI (BF, BJ, CF, CG, CI, CM, GA, GN, GQ, GW, ML, MR, NE, SN, TD, TG).

(72) Inventors; and

(75) Inventors/Applicants (for US only): COLONNA, Massimo [IT/IT]; c/o Telecom Italia S.p.A., Via G. Reiss Romoli, 274, I-10148 Torino (IT). MICHELI, Davide [IT/IT]; c/o Telecom Italia S.p.A., Via di Val Cannuta, 186, I-00166 Roma (IT).

Published:
— with international search report

(54) Title: METHOD AND SYSTEM FOR DETERMINING ROAD TRAFFIC JAMS BASED ON INFORMATION DERIVED FROM A PLMN

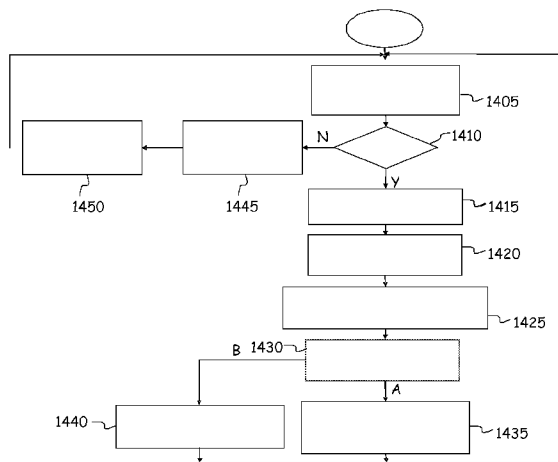

FIG. 14

(57) Abstract: A method of estimating traffic jams on a roads network, comprising: receiving information from at least one cellular PLMN (105-120) covering a geographic region wherein at least one road of the roads network to be monitored is located, wherein said information comprises data related to a call traffic handled by the cellular PLMN in an at least one area of said geographic region, and an indication related to a mobility of mobile terminals into/out of said area; providing an indication of traffic jam in said at least one road in case said call traffic handled by the cellular PLMN in the at least one area exceeds a first threshold and the indication related to the mobility of mobile terminals into/out of said area trespasses a second threshold.

WO 2009/083028 A1

METHOD AND SYSTEM FOR DETERMINING ROAD TRAFFIC JAMS BASED ON
INFORMATION DERIVED FROM A PLMN

DESCRIPTION

5 Background of the invention

Field of the invention

The present invention generally relates to methods and systems for estimating, monitoring and managing road traffic. More specifically, the present invention relates to a method and system
10 for determining traffic jams based on information derived from a cellular Public Land Mobile telephony Network (PLMN).

Description of the related art

The estimation, monitoring and management of road traffic are normally accomplished
15 based on a count of the number of vehicles that pass through one or more points of the monitored network of roads.

Vehicles counting methods are essentially of two types: manual counting methods and automatic counting methods.

Manual vehicles counting methods provide that operators, staying at the prescribed
20 monitoring points along the roads, visually count the passing vehicles.

Automatic vehicles counting methods provide for placing, on or within the road floor, detectors adapted to detect the passage of the vehicles. Different types of detectors can be used, the more common being:

- rubber pipes closed at an end and connected to a membrane at the other end; the
25 passage of a vehicle over the pipe creates a pressure thereinside that causes the membrane to flex, determining the increase of a vehicles counter;

- metal coils through which an electric current is made to flow that produces an

electromagnetic field; the passage of a vehicle alters the electromagnetic field, and this event is detected causing the increase of a vehicles counter;

- television cameras connected to automatic image recognition systems adapted to count the number of transiting vehicles.

5 The manual counting of the passing vehicles, requiring the continuous presence of people at the road sections to be monitored, is used only for time-limited monitoring campaigns.

10 On the contrary, automatic vehicles counting methods are used for monitoring the road traffic for relatively long periods of time; however, the deployment of the detectors on the roads network and their connection to a central data processing server is very expensive, especially in medium and large urban areas, which are the scenarios where the road traffic monitoring, estimation and management is more useful.

15 A known alternative to the above-described vehicles counting methods makes use of a certain number of vehicles (called "floating cars") equipped with a GPS receiver which regularly transmit to a service center its position and speed, thereby allowing the service center to estimate the road traffic.

 This method is as well very expensive, and its effectiveness is closely related to the number of circulating vehicles equipped with GPS receivers, *i.e.* to the number of floating cars; due to this, continuous monitoring of all the main roads of a certain area may not be possible.

20 In recent years, cellular PLMNs have also been used for the purposes of estimation, monitoring and management of the road traffic, thanks to the widespread presence of mobile phones among the population.

 Systems that exploit cellular PLMNs for the estimation, monitoring and management of the road traffic varies according to the type of information on the position of the vehicles that they require for their operation.

25 For example, US 5,465,289 discloses a system that makes use of sensors for monitoring communications going on in the cellular PLMN; number of calls placed, number of handovers performed, number of emergency calls are thus extracted, from which the system derives, based on a comparison of historical data, an estimation of the vehicles traffic, particularly the number of circulating vehicles and the number of accidents in a unit time.

In EP 763807 a method and system for detecting traffic jams are described; a traffic jam in a certain road section is assessed when the PLMN traffic in the network cell covering that road section exceeds a predetermined threshold. The method also allows determining the driving direction experiencing the traffic jam: assuming that the PLMN traffic threshold is exceeded firstly in a first network cell, and then in the adjacent, second network cell, located for example at the north of the first cell, it can be desumed that the driving direction experiencing the traffic jam is that directed from the north to the south.

Summary of the invention

10 The Applicant has observed that known methods and systems do not provide totally satisfactory results when the estimation of traffic jams is concerned.

In particular, concerning the solution disclosed in EP 763807, the Applicant has observed that, in practical cases, the two predetermined thresholds are not exceeded at the same time in the two cells, rather in the second cell the threshold is exceeded with a certain time delay compared to the first cell, because it is necessary to wait for the vehicles queue in the considered road section to reach the second cell. Such a delay is higher the wider the network cells, thus, particularly in extraurban areas (where the PLMN cells are usually wider compared to urban areas) it is difficult to quickly provide information about where a traffic jam exists.

20 The Applicant has tackled the problem of providing an efficient service of detection of traffic jams on roads of a roads network, useful in particular for vehicles drivers for avoiding to stay in queue.

In particular, the Applicant has tackled the problem of providing a service that is capable of determining the driving direction that may be affected by a traffic jam in a way that is not affected by the problems of known methods.

25 The Applicant has found that a solution to these and other problems may rely on the definition and use of two distinct thresholds: a first threshold related to the amount of call traffic successfully handled by a generic PLMN cell, and a second threshold related to the number of handovers successfully occurred between each PLMN cell towards any other cell adjacent thereto. The first threshold allows identifying the road section where a traffic jam is occurring, whereas the second threshold allows identifying the driving direction on that road section.

30

In particular, the present invention exploits counters that count the handled traffic handled by each cell of a generic BSC (Base Station Controller) or similar network apparatus of a cellular PLMN, and the number of handovers that took place between a generic cell and any other adjacent cell. The values of these counters are compared to predetermined thresholds, for example
5 determined by considering the counter values over a sufficiently long time span, e.g. arithmetically averaging the counter values over a time interval that may include a predetermined number of days preceding the current time instant.

At the output, an indication of the road sections experiencing a traffic jam is provided, together with the driving direction that is affected by the traffic jam.

10 According to an aspect of the present invention, a method of estimating traffic jams on a roads network is provided, comprising:

- receiving information from at least one cellular PLMN covering a geographic region wherein at least one road of the roads network to be monitored is located, wherein said information comprises data related to a call traffic handled by the cellular PLMN in an at least one area of said
15 geographic region, and an indication related to a mobility of mobile terminals into/out of said area;

- providing an indication of traffic jam in said at least one road in case said call traffic handled by the cellular PLMN in the at least one area exceeds a first threshold and the indication related to the mobility of mobile terminals into/out of said area trespasses a second threshold. Trespassing may mean either exceeding or falling below.

20 Said providing the indication of traffic jam may comprise:

- comparing the call traffic handled by the cellular PLMN in the at least one area to the first threshold;

- in case the call traffic handled by the cellular PLMN in the at least one area exceeds the first threshold, comparing the indication related to the mobility of mobile terminals into/out of said
25 area to the second threshold; and

- providing the indication of traffic jam in at least one transit direction along said road in case the mobility of mobile terminals into/out of said area trespasses the second threshold.

The method may, further comprise calculating at least one among the first and second thresholds based on historical data related to the call traffic handled by the cellular PLMN and,

respectively, to the indications related to the mobility of mobile terminals, particularly calculating averages of said historical data, and, possibly, determining standard deviations of a statistical distribution of said historical data.

5 Said at least one area may include at least one cell of the cellular PLMN, said data related to a call traffic handled by the cellular PLMN in the at least one area may include data related to a number of calls handled by said at least one cell, and said indication related to the mobility of mobile terminals into/out of said area may include data related to a number of handovers having the at least one cell as a source or as a destination.

10 Said at least one cell may include a first cell and a second cell adjacent to the first cell, and said providing an indication of traffic jam in said at least one road may include providing an indication of a driving direction on the road experiencing the traffic jam, said providing the indication of the driving direction may comprise:

- indicating that the traffic jam is experienced in a first driving direction if the number of handovers from the first cell to the second cell trespasses the second threshold; and

15 - indicating that the traffic jam is experienced in a second driving direction if the number of handovers from the second cell to the first cell trespasses the second threshold.

The method may further comprise subdividing the at least one road into elementary road segments delimited by the boundary of the at least a first and a second cell, and providing traffic jam indications for the elementary road segments.

20 According to another aspect of the present invention, a system for estimating traffic jams on a roads network is provided, adapted to:

25 - receive information from at least one cellular PLMN covering a geographic region wherein at least one road of the roads network to be monitored is located, wherein said information comprises data related to a call traffic handled by the cellular PLMN in an at least one area of said geographic region, and an indication related to a mobility of mobile terminals into/out of said area;

- provide an indication of traffic jam in said at least one road in case said call traffic handled by the cellular PLMN in the at least one area exceeds a first threshold and the indication related to the mobility of mobile terminals into/out of said area trespasses a second threshold.

For providing the indication of traffic jam the system may be adapted to:

- compare the call traffic handled by the cellular PLMN in the at least one area to the first threshold;

- in case the call traffic handled by the cellular PLMN in the at least one area exceeds the first threshold, compare the indication related to the mobility of mobile terminals into/out of said area to the second threshold; and

- provide the indication of traffic jam in at least one transit direction along said road in case the mobility of mobile terminals into/out of said area trespasses the second threshold.

The system may also be adapted to calculate at least one among the first and second thresholds based on historical data related to the call traffic handled by the cellular PLMN and, respectively, to the indications related to the mobility of mobile terminals. Said calculate may comprise calculating averages of said historical data, and possibly determining standard deviations of a statistical distribution of said historical data.

Said at least one area may include at least one cell of the cellular PLMN, said data related to a call traffic handled by the cellular PLMN in the at least one area may include data related to a number of calls handled by said at least one cell, and said indication related to the mobility of mobile terminals into/out of said area may include data related to a number of handovers having the at least one cell as a source or as a destination.

Said at least one cell may include a first cell and a second cell adjacent to the first cell, and the system may be adapted to provide an indication of a driving direction on the road experiencing the traffic jam, said provide the indication of the driving direction comprising:

- indicating that the traffic jam is experienced in a first driving direction if the number of handovers from the first cell to the second cell trespasses the second threshold; and

- indicating that the traffic jam is experienced in a second driving direction if the number of handovers from the second cell to the first cell trespasses the second threshold.

The system may be adapted to subdivide the at least one road into elementary road segments delimited by the boundary of the at least a first and a second cell, and to provide traffic jam indications for the elementary road segments.

Brief description of the drawings

These and other features and advantages of the present invention will be made clear by the following detailed description of an embodiment thereof, provided merely by way of non-limitative example, made with reference to the attached drawings, wherein:

Figure 1 synthetically shows a part of a monitored roads network, and a portion of a cellular PLMN covering the area where the considered part of the roads network is located;

Figure 2 schematically shows, in terms of functional blocks, a system according to an embodiment of the present invention for detecting traffic jams;

Figure 3 shows, in tabular form, counters of the call traffic handled by PLMN cells under the responsibility of a BSC;

Figure 4 shows, in tabular form, counters of handovers between the cells;

Figure 5 shows, in tabular form, data identifying geographic areas covered by the different PLMN cells;

Figure 6 shows, in tabular form, data geographically identifying the road sections;

Figure 7 is a schematic flowchart of a method according to an embodiment of the present invention for calculating call traffic and number of handovers thresholds, to be used for the detection of traffic jams;

Figure 8 shows, in tabular form, data regarding the call traffic in the different PLMN cells, aggregated as a result of a step of the method of **Figure 7**;

Figure 9 shows, in tabular form, data regarding the number of handovers between the cells, aggregated as a result of a step of the method of **Figure 7**;

Figure 10 shows, in tabular form, handled traffic threshold values calculated as a result of a step of the method of **Figure 7**;

Figure 11 shows, in tabular form, number of handovers thresholds calculated as a result of a step of the method of **Figure 7**;

Figure 12 exemplifies a way road sections are subdivided into elements covered by single cells;

Figure 13 is a table of start and stop coordinates of the different road elements;

Figure 14 is a schematic flowchart of a method according to an embodiment of the present invention for detecting traffic jams.

Detailed description of preferred embodiments of the invention

5 Making reference to the drawings, in **Figure 1** a part of a monitored roads network is schematically depicted. The drawing also schematically shows a portion of a cellular PLMN network that covers the geographic area where the considered part of roads network is located. Hereinafter, merely by way of example, it will be assumed that the cellular PLMN network is a GSM (Global System for Mobile communications) network, however it should be understood that the specific type
10 of cellular PLMN is not limitative to the present invention, which also applies to other types of cellular PLMN networks, like for example UMTS (Universal Mobile Telecommunications System) network or other third-generation networks.

In the drawing, reference numeral **105** denotes Base Transceiver Stations (BTSs) of the cellular PLMN; each BTS **105** covers (being the "best server" therein) a geographic area, called a
15 "cell", which in the drawing is for simplicity depicted as hexagonal in shape. It should be understood that, in practical applications, the PLMN cells generally do not have an hexagonal shape, and different cells have different area coverage (the shape and width of a generic cell depending on aspects like for example the BTS's transmission power and the morphology of the territory; for example, PLMN cells in urban area are typically smaller than PLMN in extraurban area).

20 The BTSs **105** handles the physical communication with the mobile terminals in the respective cells.

The BTSs **105** are connected to respective Base Station Controllers (BSCs) **110** through PLMN core network links **115**, transporting the PLMN traffic (calls placed by mobile terminals located in the PLMN cells, SMS or MMS messages, data traffic in case the PLMN network is
25 connected to a GPRS infrastructure, multicast-delivered contents) and signalling for the protocols that allow the proper operation of the cellular PLMN (like for example the signalling necessary for the handover procedures, which ensure the service continuity while the mobile terminals move across the territory, and the location update procedures, which allow the PLMN to keep track of the geographic macroarea (a geographic area corresponding to groups of network cells) where a
30 generic mobile terminal is located).

The BSCs **110** manage the associated BTSs **105**, routing the calls and managing the mobile terminals' mobility between different cells (*i.e.*, the handovers).

The BSCs **110** are connected to respective Mobile Switching Centers (MSCs) **120**, through links **125**, which transport the PLMN traffic and signalling for core network protocols.

5 The MSCs **120** manage the associated BSCs **110** and manage the set-up of the calls and their routing through the network.

It is pointed out that, in case of PLMNs different from a GSM network, the Radio Access Network (RAN) structure, albeit similar, may be slightly different; for example, in the case of a UMTS network, the role of the BTSs is played by so-called "Node-Bs", which are connected to
10 Radio Network Controllers (RNCs).

As schematically shown in the drawing, every BSC **110** has a local database **130** where counter values of several different counters are stored, which a PLMN operator may inspect to assess the network status. In particular, in the database **130** counter values of the handled call traffic, handled by the BTSs controlled by the BSC, and of the number of handovers involving the
15 network cells managed by the BSC are stored.

Referring to **Figure 2**, there is schematically shown a road section **205** having two lanes **205-1** and **205-2** with opposite driving directions: from right to left in lane **205-1**, and from left to right in lane **205-2**. Also shown are cells **c0** to **c5** of a cellular PLMN, for example the PLMN of **Figure 1**, and one BSC **110** managing the BTSs (not shown) of the cells **c0** to **c5**, with the local
20 database **130**.

Figure 3 schematically shows, in tabular form, a managed traffic counter of the generic BSC **110**, stored in the local database **130**. For every PLMN cell under the competence of that BSC, identified by the respective cell identifier (table columns labelled **C_Id**, one column for each cell; the cell identifiers of the cells **c0** to **c5** are assumed to be *c0*, *c1*, *c2*, *c3*, *c4* and *c5*), a plurality
25 of traffic count values is stored (table columns **Tr_Val**, one column for each cell), each count value representing the amount of call traffic (phone calls, messages, data traffic *etc.*) that the respective cell was able to handle in a respective time interval ΔT starting from a predetermined start time T_0 (in the table, the generic call traffic count value being denoted V_{ij} , where the index *i* denotes the PLMN cell and the index *j* denotes the considered time interval).

30 **Figure 4** schematically shows, also in tabular form, a number of handovers counter of the

generic BSC **110**, stored in the local database **130**. For every PLMN cell under the competence of that BSC, identified by the respective cell identifier (table columns labelled **S_C_Id**, one column for each cell; the cell identifiers of the cells **c0** to **c5** are assumed to be c_0 , c_1 , c_2 , c_3 , c_4 and c_5), the number of handovers (table columns **HO#**) occurring from the considered cell (regarded as the source cell) towards any adjacent cell (the destination cell, table columns **D_C_Id**) in the respective time intervals ΔT starting from a predetermined start time T_0 are reported (in the table, the generic handover number is denoted Nh_{ij} , where the index h denotes the considered time interval, the index i denotes the source PLMN cell and the index j denotes the destination PLMN cell). The BSC handover number counter may further keep track of the number of handovers from one cell managed by that BSC to cells that are managed by different BSCs.

Figure 2 also depicts schematically a system **210** according to an embodiment of the present invention for the detection of traffic jams on monitored roads. The system **210** is shown in terms of functional blocks, each of which can be implemented by means of software, hardware, or as a mix of hardware and software. Essentially, according to an embodiment of the present invention, the system **210** comprises a local database **215** and a processing and calculation engine **220**. The system **210** is connected to the BSCs **110** of the PLMN network (or at least to those BSC managing BTSs that cover an area of interest, where the roads to be monitored are located). The system **210** has also access to a first external database **225** storing data relating to all the BTSs **105** that cover the area where the road sections to be monitored are located, and other data useful to the system **210**. The system **210** has further access to a second external database **230** storing data related to the roads to be monitored.

The system **210** has an output **235** through which it provides to users (possibly comprising software applications) the indications about possible traffic jams.

Figure 5 schematically shows, in tabular form, a possible structure of the first external database **225**, in an embodiment of the present invention. Each row of the table corresponds to a different BTS, whereas in the table columns there are reported the unique identifier of the BTS (table column **C_Id**), its geographical position (table columns **Lat** and **Long**, standing for latitude and longitude), the number of vertexes of the generally irregular polygon defining the cell's borders (table column **N_vrtx**), and the vertexes' geographic coordinates (table columns **Coord_1**, **Coord:2**, ..., **Coor_m**); the number of vertexes may and generally does vary from cell to cell.

Figure 6 schematically shows, still in tabular form, a possible structure of the second

external database **225**, in an embodiment of the present invention. Each road to be monitored, identified by a respective road identifier (table column **Rd_Id**; the road identifiers are assumed to be *Rd1, Rd2, ..., Rdm*) can be subdivided into two or more road sections or segments, each one identified by a respective road segment identifier (table column **Seg_Id**). Of each road, or segment

5 of road, the respective start and stop geographic coordinates are provided (table columns **Start_Coord (xstart, ystart)** and **Stop_Coord (xstop, ystop)**). The sequence of start and stop coordinates determines the orientation, *i.e.* the driving direction, on that road/segment of road. For example, considering the road section **205** in **Figure 2**, points **205-A** and **205-B** identify two segments **205-1** and **205-2**, the first segment having the start coordinates corresponding to the

10 coordinates of the point **205-A** and the stop coordinates corresponding to the coordinates of the point **205-B**, whereas the second segment has the start coordinates corresponding to the coordinates of the point **205-B** and the stop coordinates corresponding to the coordinates of the point **205-A**; thus, the driving direction is from point **205-A** to point **205-B** along the first road segment (**205-1**), whereas it is from the point **205-B** to the point **205-A** along the second road

15 segment (**205-2**).

Hereinafter, the operation of the system **210** according to an embodiment of the present invention will be described.

It is convenient, at least from the description viewpoint, divide the system operation into two phases: a start phase, and a normal operation phase.

20 Referring to the schematic flowchart of **Figure 7**, in the start phase the system **210** performs, in an embodiment of the invention, the following operations.

Step **705** - the system **210** reads the list of BTSs of the cellular PLMNs contained in the first external database **225**.

25 Step **710** - the system **210** reads, from the second external database **230**, the list of roads (and respective road segments) to be monitored.

Step **715** - the system **210** reads, from the local databases **130** of the BSCs of interest, the counter values of the traffic handled by the respective network cells in a predefined time range, defined for example by a system administrator, and stores the read values in its database **215**.

30 Step **720** - the system **210** reads, from the local databases **130** of the BSCs of interest, the number of handovers in which the respective network cells have been involved, in the predefined

time range, and stores the read values in its database **215**.

Step **725** - The system **210** calculates, for every BTS covering the area of interest, respective handled traffic thresholds.

Step **730** - The system **210** calculates, for every BTS of the area of interest, respective
5 handover number thresholds for the handovers from any cell towards any other adjacent cell.

Step **735** - the system **210** subdivides the roads or road segments into elementary road segments, based on the area coverage by the different BTSs.

Step **740** - the system identifies the PLMN cell towards which a handover is performed when moving from one elementary road segment to the successive one.

10 **Figure 8** schematically shows, in tabular form, the content of the section of the system database **215** devoted to store handled call traffic counters after step **720**. The start instant $T0'$ of the monitoring time range does not in general coincide with the start instant $T0$ starting from which the BSCs stores, in their local databases **130**, the call traffic counter values – the instant $T0$ may be
15 the time instant at which the BSC is turned on, or a subsequent time instant, from which the BSC starts updating the traffic local database after having filled it. The time instant $T0'$ may instead be the current time minus the monitoring time range (usually of the order of some months) set for example by the system administrator. The values reported in the table have the same meaning as those reported in the table of **Figure 5**.

Figure 9 schematically shows, in tabular form, the content of the section of the system
20 database **215** devoted to store handovers number counters after step **725**. The values reported in the table have the same meaning as those reported in the table of **Figure 6**.

Figure 10 schematically shows a table built as a result of step **725**, in which, for every BTS (*i.e.*, for every PLMN cell), identified by the respective cell identifier, a respective handled traffic threshold Tr_Tsch is stored, calculated for example by averaging the handled traffic counter values,
25 stored in the BTS local database, in the time range of interest, set for example by the system administrator; alternatively, for every BTS, two or more handled traffic thresholds can be calculated, each one related to a specific time interval ΔT (for example, a specific time of the day, *e.g.* morning, afternoon, evening, night), calculated by averaging all the values of traffic handled by the BTS in the considered time range and in the specific time interval ΔT .

Figure 11 schematically shows a table built as a result of step **730**, in which, for every BTS (identified by the respective cell identifier) regarded as a source cell in a handover, all the possible destination BTSs (adjacent cells) are listed (*i.e.*, those BTS towards which a handover originating from the source BTS occurred), together with the corresponding thresholds of number of successful handovers. Also in this case, the thresholds can be calculated averaging all the handover values from the considered source BTS to the generic destination BTSs in the considered time range.

In step **735**, every elementary road segment has two ends that coincide with the points at which the roads or road segments to which the elementary road segment belongs intersects PLMN cells. For example, making reference to **Figure 12**, along the road segment **205-1** three elementary road segments **1203-1**, **1203-2** and **1203-3** are defined, whereas on the road segment **205-2** three road segments **1204-1**, **1204-2** and **1204-3** are defined. The points that delimit the elementary road segments are the points **1205**, **1206**, **1207** and **1208**, *i.e.* the points of intersection between the road segments **205-1** and **205-2** and the PLMN cells **c0**, **c2** and **c5**. The elementary road segments, similarly to the roads/road segments, have an orientation, thus, considering for example the elementary road segment **1203-1**, the start coordinates thereof coincide with those of the point **1205**, whereas the stop coordinates of the elementary road segment **1203-1** are those of the point **1206**. The result of this step is schematically depicted in **Figure 13**, where a table is shown in which, for every road and road segment, the constituent elementary road segments are listed, identified by an elementary road segment identifier (table column **EI_seg_Id**), together with the respective start and stop coordinates, and the identifier of the PLMN cell in whose coverage area the elementary road segment is located. In case of roads having two driving directions, two elementary segments of that road can be located in a same cell. In case of neighboring roads, like those converging towards a road crossing, a higher number of elementary road segments may be located in a same cell.

In step **740**, the system **210** identifies the PLMN cell towards which a mobile terminal makes a handover when exiting a certain elementary road segment to enter the successive elementary road segment (having as start coordinates the stop coordinates of the preceding elementary road segment). Such a PLMN cell may or may not coincide with the cell covering the elementary road segment being exited. For example, referring to **Figure 12**, and considering the elementary road segment **1203-2**, the cell towards which handover is made is the cell **c2**, whereas for the elementary road segment **1204-2** the cell towards which handover is made is the cell **c5**. The table shown in **Figure 13** is built as a result of step **740**. The identifier of the cell towards which

handover is made is inserted in the table column **HO_C_Id**. In case of a road having two driving directions, or in the case of crossing roads, the indication of the cell towards which the handover is made will allow identifying the specific elementary road segment where a traffic jam occurred, as described in the following.

5 After the start phase, the system **210** enters a normal operation phase, which is schematized by the flowchart of **Figure 14**. Essentially, at the end of every time interval $\Delta T0$, the system **210**, particularly the processing engine **215**, performs, for every PLMN cell, the following operations:

10 Step **1405** - the system **210** inquires the local database **130** of the BSC competent for the generic cell ci under consideration, and reads the value of the handled traffic counter TSi for that cell.

15 Step **1410** - The system **210** compares the read handled traffic counter value TSi with the traffic threshold value $Traffic_Th_i$ calculated for that cell ci ; at the first run, the threshold value is that calculated in the start phase, as described above, and stored in the table of **Figure 10**, whereas in subsequent runs the threshold value is that calculated in the preceding run (as described later – step **1450**).

 Step **1415** - In case the read value TSi exceeds the threshold $Traffic_Th_i$, (exit branch **Y** in the flowchart), the system **210** selects, from the table shown in **Figure 13**, all the elementary road segments covered by the cell ci .

20 Step **1420** - For all the elementary road segments thus selected, the system **210** identifies the respective cells cj destination of a handover.

 Step **1425** - The system **210** reads, from the BSC local database, the value of the number of successful handovers $HOij$ from the cell ci towards all the cells cj identified at the preceding step.

25 Step **1430** - The system **210** compares the number of successful handovers values $HOij$ with the handover number threshold values HO_Th_ij calculated, for the first run, in the start phase, as described above, or, in each subsequent run, at the preceding run, and stored in the table of **Figure 11**.

 In case for one or more of the possible handover destination cells, for example for the destination cell cj , the number of successful handovers from the source cell ci to the destination cell

c_j is lower than the respective threshold HO_Th_{ij} (exit branch **A** in the flowchart), the system provides in output an indication of a traffic jam in the elementary road segment covered by the cell c_i and having as handover destination cell the cell c_j (step **1435**).

In case for all the cells c_j being a possible destination of handovers from the origin cell c_i the number of successful handovers from the cell c_i to the handover destination cells is higher than the respective thresholds (exit branch **B** in the flowchart), the system **210** provides in output the indication of traffic jam on all the elementary road segments covered by the cell c_i , *without providing an indication of the directions along which the traffic jam is experienced* (step **1440**).

Step **1445** - In case at step **1410** the system **210** assesses that the value TS_i is lower than the threshold $Traffic_Th_i$ (exit branch **N** in the flowchart), the system **210** reads from the local database of the BSC the values of handled traffic and successful handovers for the cell c_i not read at the preceding time interval, and stores them in the local database **215**, updating the tables in **Figures 8 and 9**.

Step **1450** - The system recalculates the thresholds of handled traffic and handover number for the cell c_i , and updates the tables of **Figures 10 and 11**.

This sequence of operations is repeated at the end of each time interval ΔT_0 .

The system according to the herein described embodiment of the invention can be implemented by means of any data processing system and with any operating system (Windows, Linux, Unix, MAC OS). The computer programs for implementing the system of the present invention can be written in any programming language, such as the Ansi C++, which exhibits good programming flexibility and guarantees high performance levels in terms of processing speed; other programming languages can however be exploited, like Java, Delphi, Visual Basic. The choice of the language Ansi C++ is dictated by the.

As pointed out in the foregoing, the present invention is not limited to any specific PLMN network, which can for example be a second-generation (2G) network or a 3G network.

An advantage of the present invention is that no changes to the protocols of the cellular PLMN are required, nor changes to the hardware or the software of the mobile terminals.

The system of the present invention may communicate with the cellular PLMN apparatuses (e.g., the BSCs) by means of any communication technology, which can for example be by wired or

wireless or optical, exploiting point-to-point or point-to-multipoint connections.

The system may also receive data from two or more cellular PLMNs, run by a same or by different operators, exploiting similar or different network apparatuses.

5 The system of the present invention may have a centralized or a distributed architecture (for example, one system may be associated with every BSC), the choice depending for example on the number of roads to be monitored, on the transmission capacity of the communication links between the system and the PLMN apparatuses, the storage capacity of the system database and the processing power of the processing engine.

10 The way in which the coverage of a geographic area by the PLMN is calculated is not limitative for the present invention. For example, the PLMN area coverage may be provided by a PLMN planning tool, of the type used by PLMN operators to plan PLMNs, or it can be obtained using an *ad-hoc* tool, based for example on geometrical criteria, considering for example a generic PLMN cell as the set of territory points close to a certain BTS.

15 The way in which handled call traffic thresholds and handover numbers thresholds are calculated is not limitative for the present invention; for example, as an alternative to what described in the foregoing, the threshold may be calculated based on statistical parameters like the standard deviation, or a multiple thereof, of all the counter values in the time range of interest. The threshold could also be differentiated based on the time zone of the day (morning, afternoon, evening, night), on the day of the week, on the period of the year (season).

20 The time range in which the thresholds are calculated may be fixed or variable, for example based on the hour of the day, of the month, of the traffic load of the PLMN (number of users connected, handled traffic), based on the degree of confidence of the output that the system administrator wishes, based on the price the final user is available to pay for enjoying the service, and the like.

25 The method and system of the present invention may also exploit other types of counters among those held by the network apparatuses, like the BSCs, for example the counter of net number of successful handovers in each cell (given by the difference between the outgoing handovers and the ingoing handovers), the counter of the number of "Location Updates" (the results of the GSM network procedures that allow the network gaining knowledge of the macroarea
30 where the mobile terminals are located, which correspond to the "Routing Area Update" procedures

of UMTS networks) in entrance/exit/net related to a macroarea, the counter of the number of "Routing Area Updates" in entrance/exit/net related to a macroarea, the counter of the number of unsuccessful calls originated by the mobile terminals, and the like. These counters may also be combined together: for example, it may be possible to consider the sum of number of handovers in entrance to a cell and of the number of handovers in exit from that cell to any other cell). In general, the indication of traffic jam may be given in case the calculated threshold is trespassed, and, depending on the specific counter used, the threshold trespassing may correspond to exceeding the threshold or falling below it.

More generally, the present invention has been here described presenting some possible embodiments thereof, but those skilled in the art will readily appreciate that several modifications to the described embodiments are possible, as well as other possible embodiments, which do not depart from the scope of the protection as defined in the appended claims.

CLAIMS

1. A method of estimating traffic jams on a roads network, comprising:

5 - receiving information from at least one cellular PLMN (**105-120**) covering a geographic region wherein at least one road of the roads network to be monitored is located, wherein said information comprises data related to a call traffic handled by the cellular PLMN in an at least one area of said geographic region, and an indication related to a mobility of mobile terminals into/out of said area;

10 - providing an indication of traffic jam in said at least one road in case said call traffic handled by the cellular PLMN in the at least one area exceeds a first threshold and the indication related to the mobility of mobile terminals into/out of said area trespasses a second threshold.

2. The method of claim 1, wherein said providing the indication of traffic jam comprises:

15 - comparing (**1410**) the call traffic handled by the cellular PLMN in the at least one area to the first threshold;

- in case the call traffic handled by the cellular PLMN in the at least one area exceeds the first threshold, comparing (**1430**) the indication related to the mobility of mobile terminals into/out of said area to the second threshold; and

20 - providing (**1435**) the indication of traffic jam in at least one transit direction along said road in case the mobility of mobile terminals into/out of said area trespasses the second threshold.

3. The method of claim 1 or 2, further comprising calculating at least one among the first and second thresholds based on historical data related to the call traffic handled by the cellular PLMN and, respectively, to the indications related to the mobility of mobile terminals.

25

4. The method of claim 3, wherein said calculating comprises calculating averages of said historical data.

5. The method of claim 3, wherein said calculating comprises determining standard deviations of a statistical distribution of said historical data.

5 6. The method of any one of the preceding claims, wherein said at least one area includes at least one cell of the cellular PLMN, said data related to a call traffic handled by the cellular PLMN in the at least one area include data related to a number of calls handled by said at least one cell, and said indication related to the mobility of mobile terminals into/out of said area include data related to a number of handovers having the at least one cell as a source or as a destination.

10

7. The method of claim 6, wherein said at least one cell includes a first cell and a second cell adjacent to the first cell, and wherein said providing an indication of traffic jam in said at least one road includes providing an indication of a driving direction on the road experiencing the traffic jam, said providing the indication of the driving direction comprising:

15 - indicating that the traffic jam is experienced in a first driving direction if the number of handovers from the first cell to the second cell trespasses the second threshold; and

 - indicating that the traffic jam is experienced in a second driving direction if the number of handovers from the second cell to the first cell trespasses the second threshold.

20 8. The method of claim 7, further comprising subdividing the at least one road into elementary road segments delimited by the boundary of the at least a first and a second cell, and providing traffic jam indications for the elementary road segments.

9. A system for estimating traffic jams on a roads network, adapted to:

25 - receive information from at least one cellular PLMN (**105-120**) covering a geographic region wherein at least one road of the roads network to be monitored is located, wherein said information comprises data related to a call traffic handled by the cellular PLMN in an at least one area of said geographic region, and an indication related to a mobility of mobile terminals into/out of

said area;

- provide an indication of traffic jam in said at least one road in case said call traffic handled by the cellular PLMN in the at least one area exceeds a first threshold and the indication related to the mobility of mobile terminals into/out of said area trespasses a second threshold.

5

10. The system of claim 9, wherein for providing the indication of traffic jam the system is adapted to:

- compare (**1410**) the call traffic handled by the cellular PLMN in the at least one area to the first threshold;

10

- in case the call traffic handled by the cellular PLMN in the at least one area exceeds the first threshold, compare (**1430**) the indication related to the mobility of mobile terminals into/out of said area to the second threshold; and

- provide (**1435**) the indication of traffic jam in at least one transit direction along said road in case the mobility of mobile terminals into/out of said area trespasses the second threshold.

15

11. The system of claim 9 or 10, adapted to calculate at least one among the first and second thresholds based on historical data related to the call traffic handled by the cellular PLMN and, respectively, to the indications related to the mobility of mobile terminals.

20

12. The system of claim 11, wherein said calculate comprises calculating averages of said historical data.

13. The system of claim 12, wherein said calculate comprises determining standard deviations of a statistical distribution of said historical data.

25

14. The system of any one of claims 9 to 13, wherein said at least one area includes at least one cell of the cellular PLMN, said data related to a call traffic handled by the cellular PLMN in

the at least one area include data related to a number of calls handled by said at least one cell, and said indication related to the mobility of mobile terminals into/out of said area include data related to a number of handovers having the at least one cell as a source or as a destination.

5 15. The system of claim 14, wherein said at least one cell includes a first cell and a second cell adjacent to the first cell, and wherein the system is adapted to provide an indication of a driving direction on the road experiencing the traffic jam, said provide the indication of the driving direction comprising:

10 - indicating that the traffic jam is experienced in a first driving direction if the number of handovers from the first cell to the second cell trespasses the second threshold; and

 - indicating that the traffic jam is experienced in a second driving direction if the number of handovers from the second cell to the first cell trespasses the second threshold.

15 16. The system of claim 15, adapted to subdivide the at least one road into elementary road segments delimited by the boundary of the at least a first and a second cell, and to provide traffic jam indications for the elementary road segments.

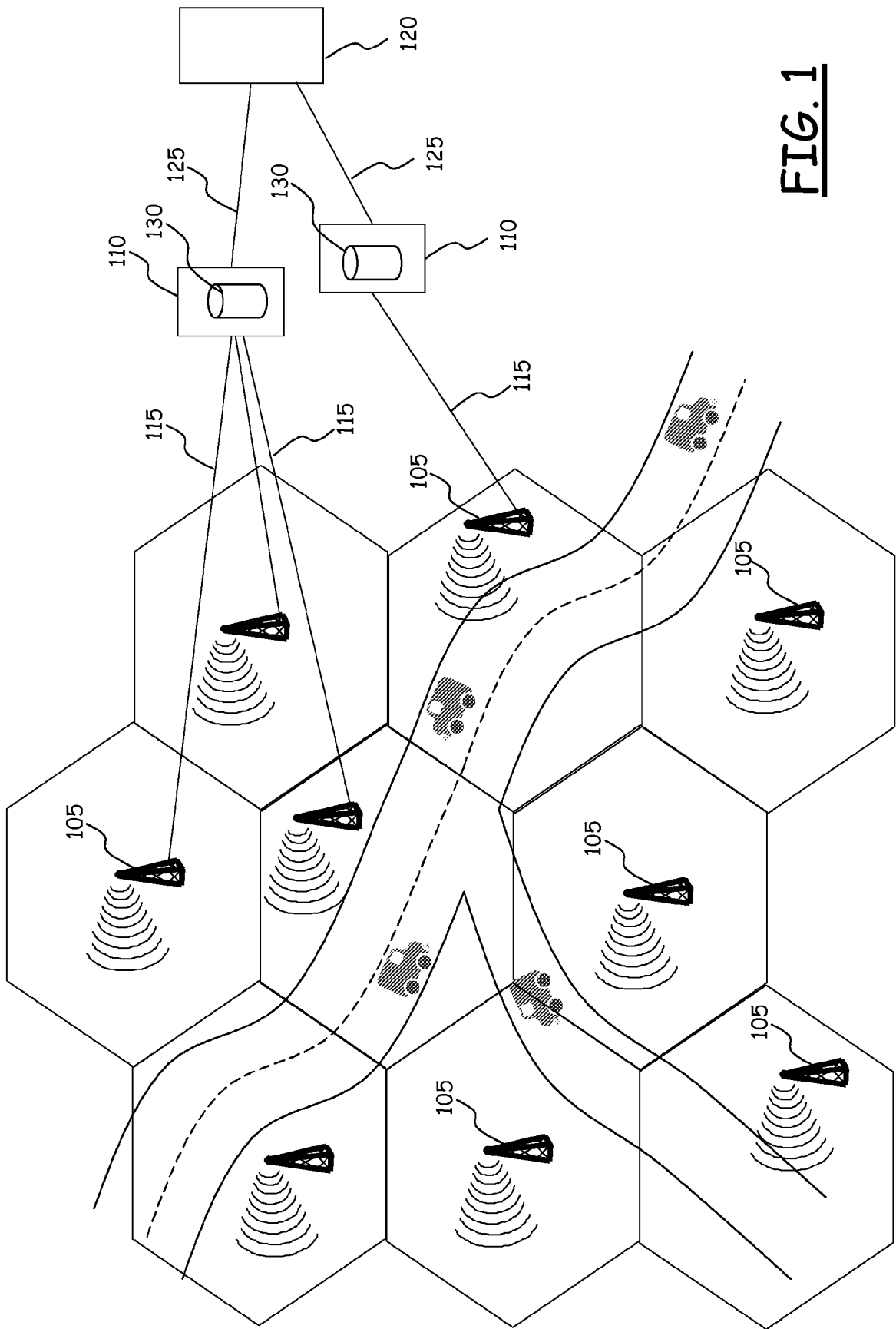

FIG. 1

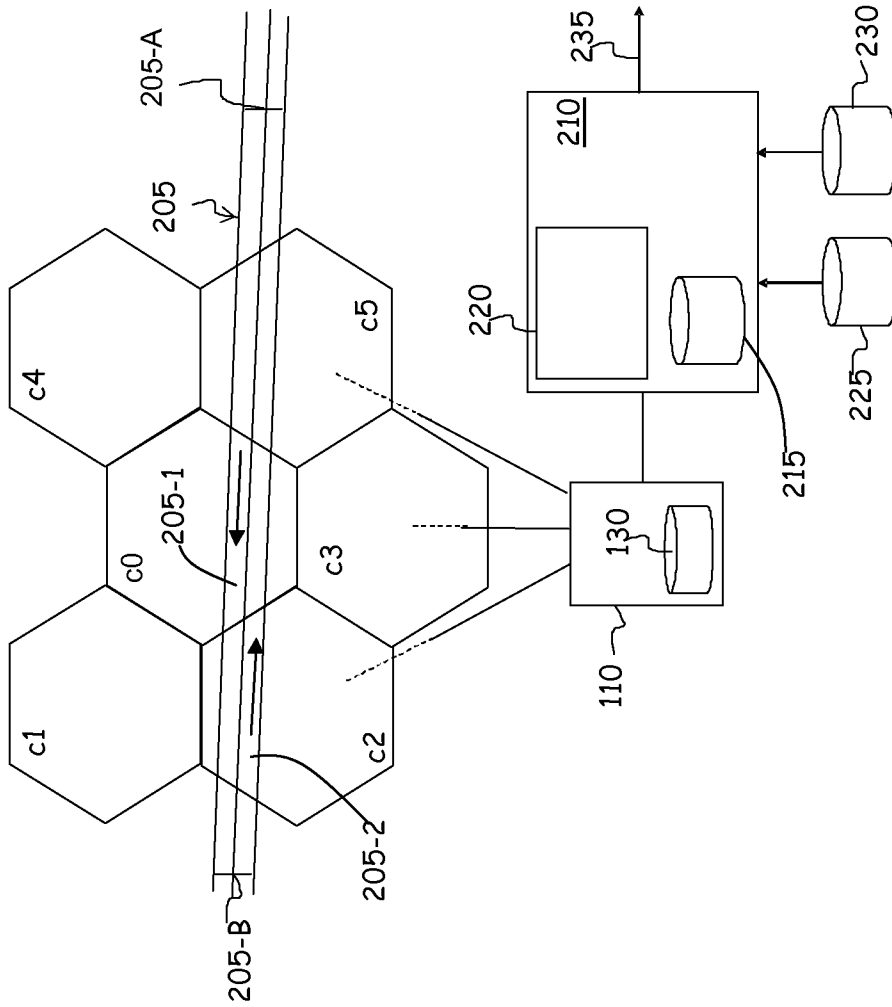

FIG. 2

FIG. 3

Tstart	Tstop	C_Id	Tr_Val	C_Id	Tr_Val	C_Id	Tr_Val
T0	T0+ΔT	c0	V00	c1	V01	c6	V06
T0+ΔT	T0+2*ΔT	c0	V10	c1	V11	c6	V16
T0+n*ΔT	T0+(n+1)*ΔT	c0	Vn0	c1	Vn1	c6	Vn6

Tstart	Tstop	S_C_Id	D_C_Id	HO#	D_C_Id	HO#	D_C_Id	HO#
T0	T0+ΔT	c0	c1	N0_01	c2	N0_02	ck	N0_0k
T0+ΔT	T0+2*ΔT	c0	c1	N1_01	c2	N1_02	ck	N1_0k
T0+n*ΔT	T0+(n+1)*ΔT	c0	c1	Nn_01	c2	Nn_02	ck	Nn_0k
T0	T0+ΔT	ci	c1	N0_i1	c2	N0_i2	ck	N0_ik
T0+ΔT	T0+2*ΔT	ci	c1	N1_i1	c2	N1_i2	ck	N1_ik
T0+n*ΔT	T0+(n+1)*ΔT	ci	c1	Nn_i1	c2	Nn_i2	ck	Nn_ik

FIG. 4

FIG. 5

C_Id	Lat	Long	N_vrtx	Coord_1	Coord_2	Coord_m
c0	Lat_0	Lon_0	num_0	(x10, y10)	(x20, y20)	(xm0, ym0)
c1	Lat_1	Lon_1	num_1	(x11, y11)	(x21, y21)	
ci	Lat_i	Lon_i	num_i	(x1i, y1i)	(x2i, y2i)	(xmi, ymi)
cn	Lat_n	Lon_n	num_n	(x1n, y1n)	(x2n, y2n)	(xmn, ymn)

FIG. 6

Rd_Id	Seg_Id	Start_Coord (xstart, ystart)	Stop_Coord (xstop, ystop)
Rd1	Seg1	xstart_11; ystart_11	xstop_11; ystop_11
	Seg2	xstart_12; ystart_12	xstop_12; ystop_12
	Seg3	xstart_13; ystart_13	xstop_13; ystop_13
Rdi	Seg1	xstart_i1; ystart_i1	xstop_i1; ystop_i1
	Seg2	xstart_i2; ystart_i2	xstop_i2; ystop_i2
Rdn	Seg1	xstart_n1; ystart_n1	xstop_n1; ystop_n1
	Seg2	xstart_n2; ystart_n2	xstop_n2; ystop_n2

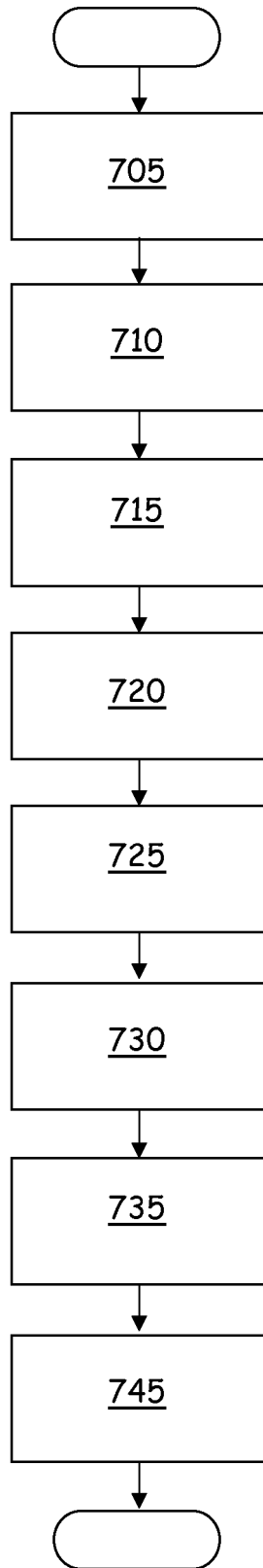

FIG. 7

FIG. 8

start	Tstop	C_Id	Tr_Val	C_Id	Tr_Val	C_Id	Tr_Val
$T0'+\Delta T$	c0	V00'	c1	V01'	c6	V06'	
$T0'+2*\Delta T$	c0	V10'	c1	V11'	c6	V16'	
$+n*\Delta T$	$T0'+(n+1)*\Delta T$	Vn0'	c1	Vn1'	c6	Vn6'	

Tstart	Tstop	S_C_Id	D_C_Id	HO#	D_C_Id	HO#	D_C_Id	HO#
$T0'$	$T0'+\Delta T$	c0	c1	N0_01'	c2	N0_02'	ck	N0_0k'
$T0'+\Delta T$	$T0'+2*\Delta T$	c0	c1	N1_01'	c2	N1_02'	ck	N1_0k'
$T0'+n*\Delta T$	$T0'+(n+1)*\Delta T$	c0	c1	Nn_01'	c2	Nn_02'	ck	Nn_0k'
$T0'$	$T0'+\Delta T$	ci	c1	N0_i1'	c2	N0_i2'	ck	N0_ik'
$T0'+\Delta T$	$T0'+2*\Delta T$	ci	c1	N1_i1'	c2	N1_i2'	ck	N1_ik'
$T0'+n*\Delta T$	$T0'+(n+1)*\Delta T$	ci	c1	Nn_i1'	c2	Nn_i2'	ck	Nn_ik'

FIG. 9

S_C_Id	D_C_Id	HO_Thr	D_C_Id	HO_Thr
c0	c1	HO_Th_01	cm	HO_Th_0m
ci	c0	HO_Th_i0	cm	HO_Th_im
cn	c0	HO_Th_n0	cm-1	HO_Th_nm-1

FIG. 11

C_Id	Tr_Thr
c0	Traffic_Th_1
c1	Traffic_Th_2
ci	Traffic_Th_i
cn	Traffic_Th_n

FIG. 10

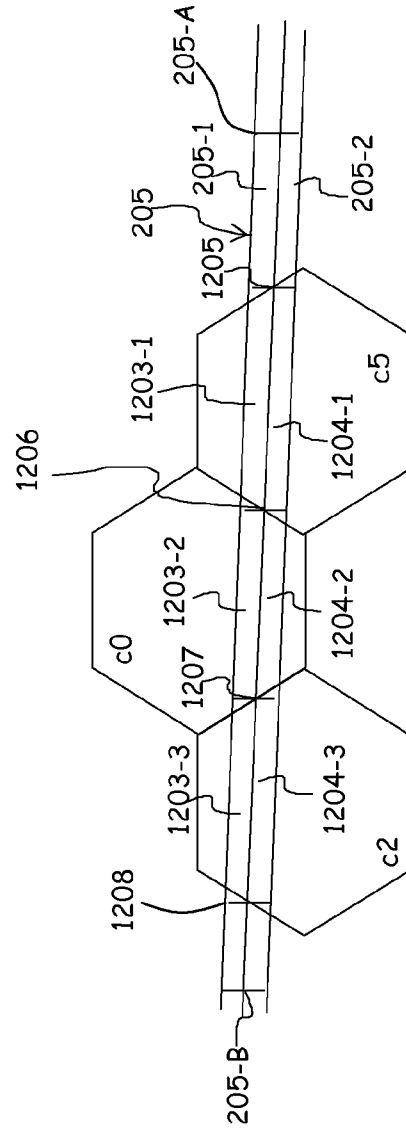

FIG. 12

Rd_Id	Seg_Id	EI_seg_Id	Start_Coord (xstart, ystart)	Stop_Coord (xstop, ystop)	C_Id	HO_C_Id
Street1	Seg1					
	Seg2	Micro-Seg2_1	xstart_12_1; ystart_12_1	xstop_12_1; ystop_12_1	c1	c2
		Micro-Seg2_2	xstart_12_2; ystart_12_2	xstop_12_2; ystop_12_2	c2	c3
		Micro-Seg2_3	xstart_12_3; ystart_12_3	xstop_12_3; ystop_12_3	c3	c4
		Micro-Seg2_4	xstart_12_4; ystart_12_4	xstop_12_1; ystop_12_4	c4	c5
Streeti	Seg1		xstart_i1; ystart_i1	xstop_i1; ystop_i1		
	Seg2		xstart_i2; ystart_i2	xstop_i2; ystop_i2		

FIG. 13

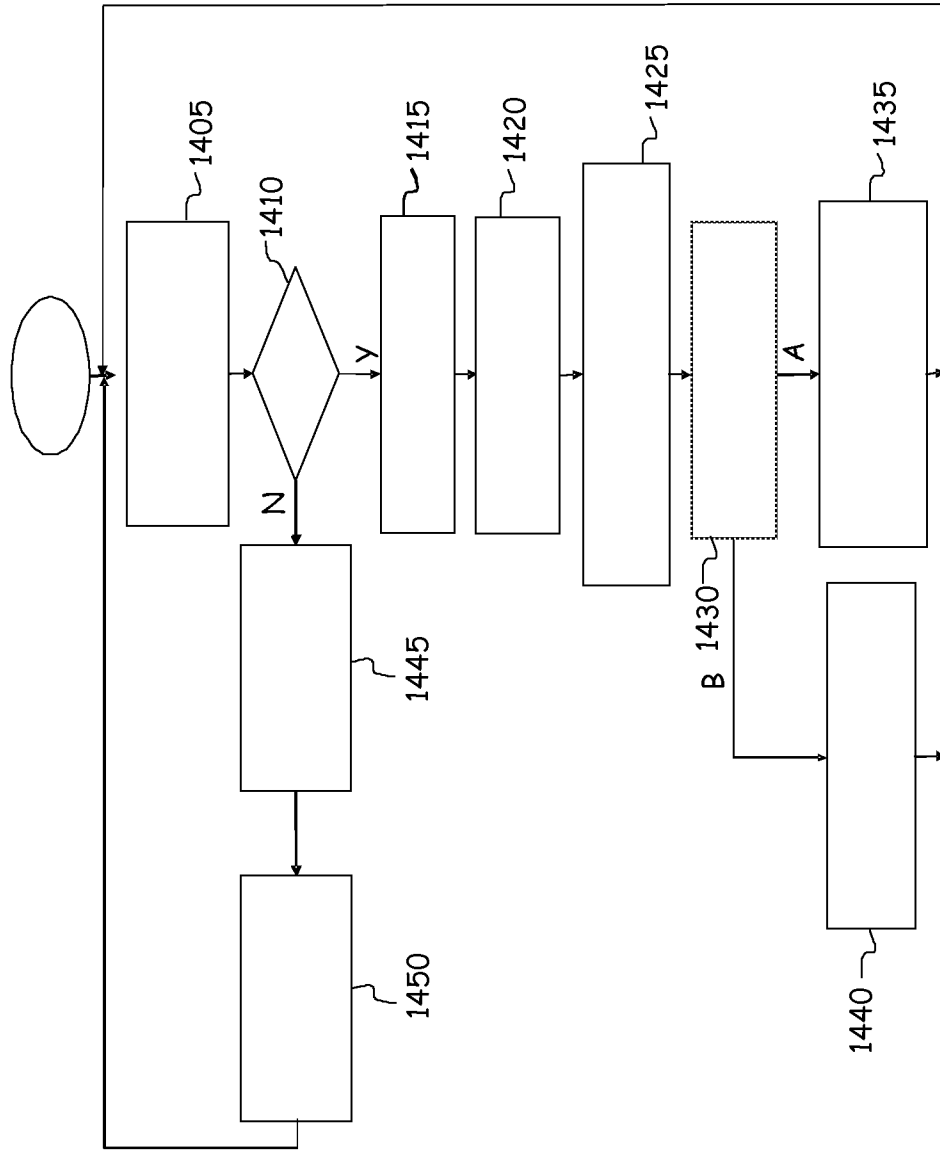

FIG. 14

INTERNATIONAL SEARCH REPORT

International application No
PCT/EP2007/064580

A. CLASSIFICATION OF SUBJECT MATTER
INV. G08G1/01

According to International Patent Classification (IPC) or to both national classification and IPC

B. FIELDS SEARCHED

Minimum documentation searched (classification system followed by classification symbols)
G08G

Documentation searched other than minimum documentation to the extent that such documents are included in the fields searched

Electronic data base consulted during the international search (name of data base and, where practical, search terms used)

EPO-Internal, WPI Data

C. DOCUMENTS CONSIDERED TO BE RELEVANT

Category*	Citation of document, with indication, where appropriate, of the relevant passages	Relevant to claim No.
X	EP 1 501 321 A (VODAFONE HOLDING GMBH [DE]) 26 January 2005 (2005-01-26) paragraphs [0002], [0005], [0011] - [0013], [0020], [0028], [0033], [0037], [0038] claims 1,4,9,12,17,20	1-16
X	EP 0 763 807 A (AT & T CORP [US] AT & T WIRELESS SERVICES INC [US]) 19 March 1997 (1997-03-19) cited in the application column 2, line 23 - column 3, line 19 figures 1,4 claims 1,6-11 column 5, lines 34-59 column 6, lines 39-43	1-16
	-/--	

Further documents are listed in the continuation of Box C.

See patent family annex.

* Special categories of cited documents :

- *A* document defining the general state of the art which is not considered to be of particular relevance
- *E* earlier document but published on or after the international filing date
- *L* document which may throw doubts on priority claim(s) or which is cited to establish the publication date of another citation or other special reason (as specified)
- *O* document referring to an oral disclosure, use, exhibition or other means
- *P* document published prior to the international filing date but later than the priority date claimed

- *T* later document published after the international filing date or priority date and not in conflict with the application but cited to understand the principle or theory underlying the invention
- *X* document of particular relevance; the claimed invention cannot be considered novel or cannot be considered to involve an inventive step when the document is taken alone
- *Y* document of particular relevance; the claimed invention cannot be considered to involve an inventive step when the document is combined with one or more other such documents, such combination being obvious to a person skilled in the art.
- *Z* document member of the same patent family

Date of the actual completion of the international search

18 June 2008

Date of mailing of the international search report

25/06/2008

Name and mailing address of the ISA/

European Patent Office, P.B. 5818 Patentlaan 2
NL - 2280 HV Rijswijk
Tel. (+31-70) 340-2040, Tx. 31 651 epo nl,
Fax: (+31-70) 340-3016

Authorized officer

Quartier, Frank

INTERNATIONAL SEARCH REPORT

International application No

PCT/EP2007/064580

C(Continuation). DOCUMENTS CONSIDERED TO BE RELEVANT		
Category*	Citation of document, with indication, where appropriate, of the relevant passages	Relevant to claim No.
X	DE 196 38 798 A1 (DEUTSCHE TELEKOM MOBIL [DE]) 26 March 1998 (1998-03-26) column 1, line 45 - column 2, line 35 claims 1,2,6	1,3,6,9, 11,14
A	US 5 465 289 A (KENNEDY JR JOSEPH P [US]) 7 November 1995 (1995-11-07) cited in the application figures 1,4 column 1, lines 41-59 column 5, lines 1-19 claims 1,2,8,9	1-16
A	DE 102 25 033 A1 (UNIV HANNOVER [DE]) 24 December 2003 (2003-12-24) paragraphs [0008], [0009], [0012], [0017] - [0019] claims 1-3,9 figure 1	1-16

INTERNATIONAL SEARCH REPORT

Information on patent family members

International application No PCT/EP2007/064580
--

Patent document cited in search report	A	Publication date	DE	Patent family member(s)	Publication date
EP 1501321	A	26-01-2005	DE	10333793 A1	14-04-2005
EP 0763807	A	19-03-1997	CA	2183284 A1	15-03-1997
			DE	69611274 D1	25-01-2001
			DE	69611274 T2	09-08-2001
			JP	9128679 A	16-05-1997
			US	5732383 A	24-03-1998
DE 19638798	A1	26-03-1998	NONE		
US 5465289	A	07-11-1995	US	5559864 A	24-09-1996
DE 10225033	A1	24-12-2003	NONE		