

(12) INTERNATIONAL APPLICATION PUBLISHED UNDER THE PATENT COOPERATION TREATY (PCT)

(19) World Intellectual Property Organization
International Bureau



(43) International Publication Date
16 May 2002 (16.05.2002)

PCT

(10) International Publication Number
WO 02/38329 A1

- (51) International Patent Classification⁷: **B23P 15/00**, F16B 37/06, B21K 1/60, C21D 8/10
- (74) Agent: **MACKENZIE, Andrew, Bryan**; Sommerville & Rushton, 45 Grosvenor Road, St. Albans, Hertfordshire AL1 3AW (GB).
- (21) International Application Number: PCT/GB01/04526
- (81) Designated States (*national*): AE, AG, AL, AM, AT, AU, AZ, BA, BB, BG, BR, BY, BZ, CA, CH, CN, CO, CR, CU, CZ, DE, DK, DM, DZ, EC, EE, ES, FI, GB, GD, GE, GH, GM, HR, HU, ID, IL, IN, IS, JP, KE, KG, KP, KR, KZ, LC, LK, LR, LS, LT, LU, LV, MA, MD, MG, MK, MN, MW, MX, MZ, NO, NZ, PH, PL, PT, RO, RU, SD, SE, SG, SI, SK, SL, TJ, TM, TR, TT, TZ, UA, UG, US, UZ, VN, YU, ZA, ZW.
- (22) International Filing Date: 11 October 2001 (11.10.2001)
- (25) Filing Language: English
- (26) Publication Language: English
- (30) Priority Data: 0027388.8 9 November 2000 (09.11.2000) GB
- (84) Designated States (*regional*): ARIPO patent (GH, GM, KE, LS, MW, MZ, SD, SL, SZ, TZ, UG, ZW), Eurasian patent (AM, AZ, BY, KG, KZ, MD, RU, TJ, TM), European patent (AT, BE, CH, CY, DE, DK, ES, FI, FR, GB, GR, IE, IT, LU, MC, NL, PT, SE, TR), OAPI patent (BF, BJ, CF, CG, CI, CM, GA, GN, GQ, GW, ML, MR, NE, SN, TD, TG).
- (71) Applicant (*for all designated States except US*): **TEXTRON FASTENING SYSTEMS LIMITED** [GB/GB]; Mundells, Welwyn Garden City, Hertfordshire AL7 1EZ (GB).
- (72) Inventors; and
- (75) Inventors/Applicants (*for US only*): **DENHAM, Keith** [GB/GB]; 6 Old Forge Close, Welwyn, Hertfordshire AL6 0SR (GB). **JOKISCH, Matthias** [DE/DE]; Ehlersstrasse 2a, 30853 Langenhagen (DE).
- Published:**
— with international search report
- For two-letter codes and other abbreviations, refer to the "Guidance Notes on Codes and Abbreviations" appearing at the beginning of each regular issue of the PCT Gazette.*

(54) Title: METHOD OF MANUFACTURING A BLIND THREADED INSERT

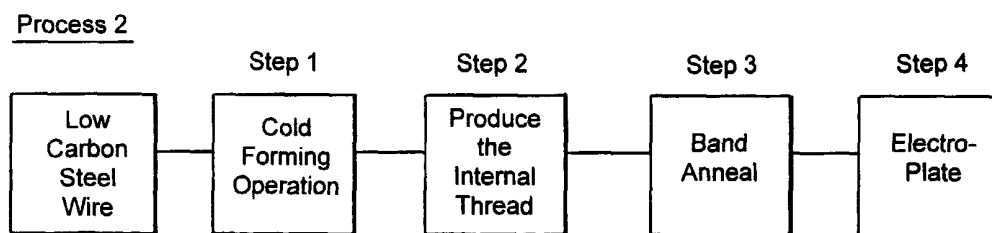

(57) Abstract: A method of manufacturing a blind threaded insert from metal which method comprises the steps of at least partially forming the insert, by a cold-forming process, other than the internal thread; forming the internal thread; and annealing the appropriate part of the insert to promote later deformation during installation.



WO 02/38329 A1

Method of Manufacturing a Blind Threaded Insert

The invention relates to a method of manufacturing a blind threaded insert from metal, which insert can be inserted through a workpiece and then radially expanded to secure it to the workpiece. In this context, "blind" means that the insert can be installed by access to one side only of the workpiece. Such blind inserts are well known in manufacturing industry, and are available, for example, under the names Avdel Large Flange Hexsert and Avdel Thin Sheet Nutsert (the words AVDEL, HEXSERT, NUTSERT and THIN SHEET NUTSERT are Registered Trade Marks).

10

Blind threaded inserts are usually manufactured either by machining from bar, or using cold forming techniques and bulk annealing processes, the latter method providing the most economic manufacturing route. The strength of such fasteners when installed by the end user in the application is adequate for light or medium duty. Consequently, for heavy duty applications blind threaded inserts are not used.

15

The present invention aims to provide a new manufacturing method for producing blind threaded inserts which have a strength compatible with heavy duty applications.

20

In the conventional manufacturing route, there is some increase in hardness and tensile strength in the threaded portion resulting from the one cold working operation which is carried out after the bulk annealing process, but of course any benefit in respect of increased strength of the cold working processes prior to annealing is lost.

25

The present invention provides, in one of its aspects, a method of manufacturing as set out in Claim 1.

30

The present invention provides, in another of its aspects, a method of manufacturing as set out in Claim 6. According to this method, the bulk annealing process is used prior or subsequent to producing the internal threads and then the thread portion is induction hardened. In this case the material from which the inserts are manufactured is one which has sufficient carbon or other alloying elements to respond to the induction hardening process.

35

Further features of the invention are set out in the other appended claims. The invention includes an insert manufacture by a method according to the invention.

5 Some specific examples of the invention will now be described by way of example and with reference to the accompanying drawings, in which:

Figures 1a and 1b show a blind threaded insert before and after installation in a workpiece.

10 Figures 2a, 2b, and 2c show the manufacturing process routes for the manufacture of blind threaded inserts.

15 Figures 3a and 3b, 4a and 4b show the configuration of installed blind threaded inserts when a tightening torque is applied to the mating bolt.

Figure 6 shows the hardness and corresponding tensile strength of the material in the nut portion of the insert and Figures 5a and 5b show the position on the insert at which these hardness values relate.

20 Figure 7 shows a particular type of workpiece in which inserts of the present invention may be used to advantage.

Figure 8 shows an insert installed in such a workpiece, and

25 Figure 9 shows a post-installation process being applied to the workpiece.

Figures 10 and 11 show the hardness along the longitudinal sections.

30 In Figures 1, 3, 4, 5a, 8, 9, 10 and 11 the insert is shown in longitudinal axial section, and in Figure 5b in cross-section, the cross-section being taken on the arrowed section line on the longitudinal section on Figure 5a.

Figures 2a, 4a and 4b illustrate the prior art.

35 The manufacturing methods in Step 1 of Figures 2a, 2b, and 2c, are performed using a progressive cold-heading machine. The manufacturing method for

producing the internal thread as in Step 3 of Figures 2a and 2c, and Step 2 of Figure 2b is commonly referred to as roll-tapping. These manufacturing methods are of the type commonly used to make blind threaded inserts and are well known and understood by those skilled in the art.

5

Thus, referring first to Figure 1a the blind threaded insert 11 could be produced by any of the processes shown in Figures 2a, 2b, or 2c. The example shown is cylindrical and is intended to fit in a suitably sized circular hole in the workpiece 19 (Figure 1b). In other examples not shown, the outer surface 12 of the insert may be
10 polygonal in cross-section, for example hexagonal or square to fit in a correspondingly shaped hole in the application.

Zone 1 of the insert shown in Figure 1a is required to be sufficiently ductile to plastically deform by the action of the installation tool (not shown) to form the blind-side bulb 13 in Figure 1b. In prior art examples of insert manufacturing process, this
15 ductility is achieved by carrying out an annealing process on the whole of the insert, usually as a bulk process applied to the whole batch as shown in Step 2 Figure 2a. In the prior art insert manufacturing method shown as Process 1 Figure 2a, the internal thread 14 Figure 1a is produced at Step 3 Figure 2a. By producing it this
20 way after the annealing process, there is some local work hardening in the thread region. The hardness of the insert blank after the bulk annealing process is typically 115 Hv (Vickers Hardness Number), the insert material being typically low carbon steel having 0.1% Carbon. This hardening of the thread is localised to the material near the thread surface. A short distance from the thread surface, the hardness
25 rapidly reduces, as shown on the 'Process 1' line in Figure 6. If an attempt were made to use such an insert in heavy duty applications where the mating bolt requires a high level of tightening torque, then because the strength of the material at this section (as shown in Figures 5b and 6) is relatively low, the radial force created by the tightening of the bolt 15 in Figure 4a against the thread in the insert
30 can be sufficient to cause the nut portion to expand radially as shown 16 in Figures 4a and 4b. This causes a reduction in contact area between the thread on the bolt 17 in Figure 4b and the internal thread in the insert 14¹. The reduction in contact area together with the lower thread hardness of the insert results in thread failure at a relatively low tightening torque. For example, an insert with an M8 thread will fail
35 at a tightening torque of about 40 to 45 Nm.

With an insert manufactured by a process of the present example (Process 2 Figure 2b), the work hardening of the material which is created during the wire manufacturing process and when the wire is converted into an insert by the cold forming operation Step 1 and the roll tapping operation Step 2 in Figure 2b is accumulative, resulting in a high level of hardness as shown in Figure 6 for Process 2. Thus an insert 18 (Figure 3a) manufactured by this process can be satisfactorily installed in the workpiece 19 because the band annealing Step 3 (Figure 2b) provides sufficient ductility to allow the blind bulb 13 to form without cracking and the internally threaded portion 20 of the insert has sufficient strength to resist expansion when the bolt 21 (Figure 3a) is tightened even to very high tightening torques.

For example an M8 insert manufactured by a process of the present invention can be tightened to torques in excess of 70 Nm without failure. Such an insert is compatible in respect of tightening torques to grade 10.9 and 12.9 bolts.

The hardness profile created by the band annealing operation can be varied according to the selected process parameters such as the geometry of the band annealing coil, the machine power settings and the process time. Due to the severity of plastic deformation when the blind bulb is formed it is desirable to have a smooth transition from the annealed zone to the hard zone. Such a profile is shown in Figure 10, where an M8 insert has a hardness transition between insert flange 28 and the deforming cylindrical section 29 over a distance of approximately 1.5mm, and a hardness transition between the threaded portion 30 and section 29 over a distance of approximately 2.0mm.

In a further embodiment of the invention, an insert which has the requisite ductility in Zone 1 (Figure 1a) and a high strength in Zone 2 for compatibility with grade 10.9 and 12.9 bolts can be produced using manufacturing Process 3 in Figure 2c. In this case the insert is manufactured from a medium carbon steel having typically 0.3 to 0.35% carbon. The bulk annealing process Step 2 (Figure 2c) produces a hardness of typically 140 Hv. At this hardness, the insert has sufficient ductility to sustain the blind side bulging during installation without fracturing. Step 4 of Process 3 (Figure 2c) involves the induction hardening of Zone 2 Figure 1a. This process produces a generally even hardness in Zone 2 of about 350 to 400 Hv as shown in the Process 3 line in Figure 6.

The induction hardening process is controlled such that the hardening does not extend into Zone 1, otherwise when the blind bulb is formed it would be prone to fracture at the annealed-hardened junction. For this reason, the induction hardened region does not extend fully the length of Zone 2. For an M8 insert, for example, the unhardened portion of Zone 2 would be approximately 0.5mm as shown in Figure 11.

It would be possible to modify the method of the example by interchanging Steps 3 and 4 of Figure 2c, so that the internal thread is formed after the induction hardening step.

An advantage of inserts of the present invention manufactured by Process 2 (Figure 2b) or Process 3 (Figure 2c) is that they are particularly suitable for use in workpieces known as hydroformed sections. In such workpieces, shown in Figure 7, the hole into which the insert is to be installed is punched during the hydroforming process. Because this is a blind operation there is not a die as in conventional hole piercing. This results in a dimpling effect in which the material at the edge of the hole is lower than the top surface of the workpiece. Another feature of punching holes in hydroformed sections is that the pierce slug 23 in Figure 7 purposely is left attached to the parent workpiece.

The advantage of using an insert of the present invention will become apparent from the following.

Referring to Figure 8, which is a longitudinal section through a blind insert installed in a hydroformed section such as shown in Figure 7, it can be seen that the blind bulb 13¹ at the position on the circumference of hole 22 where it meets the retained slug 23 is partially obstructed by the slug, to the extent that the blind bulb 13 is unable to form evenly. However, because the insert is ductile in this region it is able to plastically deform around this obstruction. Furthermore, in some instances, the dimpling effect on the hole is such that the top surface 24 of the installed insert is below the surface 25 of the hydroformed workpiece.

In such cases, a tool can be used as shown in Figure 9 consisting of a drawbolt 26 and a flat anvil 27 in which sufficient pulling force is applied to the insert to cause the dimple in the workpiece to reduce until the top of the insert 24 (Figure 9) is at the

same level as the top face of the workpiece 25. Of course, if the top face of the insert 24 was required to be above the level of workpiece 25 then an anvil which had an annular recess in its front face could be used. It is also feasible to combine the action of the drawbolt and anvil with that of the insert installation tool. The operation of using a drawbolt and anvil to flatten the dimple requires a relatively high force, which force has to be transmitted through the thread of the insert, through the blind side bulb, onto the workpiece. An insert which has high strength of thread combined with high ductility in the blind side bulbing region is ideal for such applications. The insert of the present example meets this requirement.

10

The invention is not restricted to the details of the foregoing examples.

CLAIMS

1. A method of manufacturing a blind threaded insert from metal which method comprises the steps of:
- 5
- (a) at least partially forming the insert, by a cold-forming process, other than the internal thread;
 - (b) forming the internal thread; and
 - (c) annealing the appropriate part of the insert to promote later
- 10 deformation during installation.
2. A process as in claim 1, in which the high ductility in the part of the insert which plastically deforms during installation is obtained by band annealing that part of the insert.
- 15
3. A process as in claim 2 in which the band annealing produces a controlled hardness contour from the part of the insert requiring high ductility to the part of the insert requiring high strength.
- 20
4. A method as claimed in any of the preceding claims, in which the metal is low carbon steel.
5. A method as claimed in claim 2, which is modified by the interchange in position of the steps of forming the internal thread and of band-annealing the
- 25 appropriate part of the insert.
6. A method of manufacturing a blind threaded insert from metal, which method comprises the steps of:
- (a) at least partially forming the fastener, by a cold-forming process, other than the internal thread;
 - (b) annealing the insert;
 - (c) forming the internal thread; and
 - (d) induction hardening at least part of the threaded part.
- 30

7. A method as claimed in claim 6, which is modified by the interchange of the positions of the steps of forming the internal thread and of annealing the insert.
- 5 8. A method as claimed in claim 6 or claim 7 in which the metal is medium carbon steel.
9. A method as claimed in any of the preceding claims, which includes a subsequent surface-treatment step.
- 10 10. A method as claimed in claim 9, in which the surface-treatment step comprises electroplating.
11. A method of manufacturing a blind threaded insert from metal, which method is substantially as hereinbefore described, and illustrated, the accompanying drawings.
- 15 12. A blind threaded insert manufactured by a method according to any of the preceding claims.

1/8

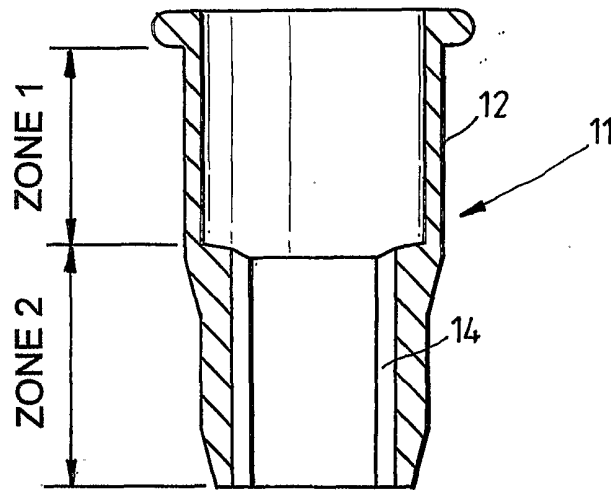

Fig. 1a

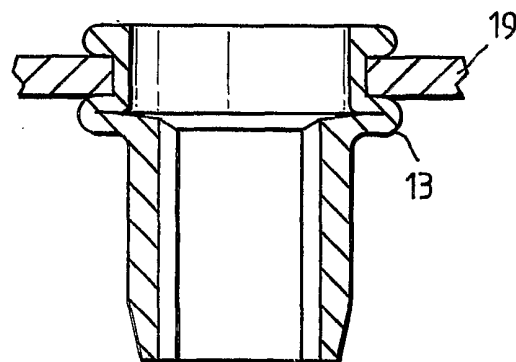
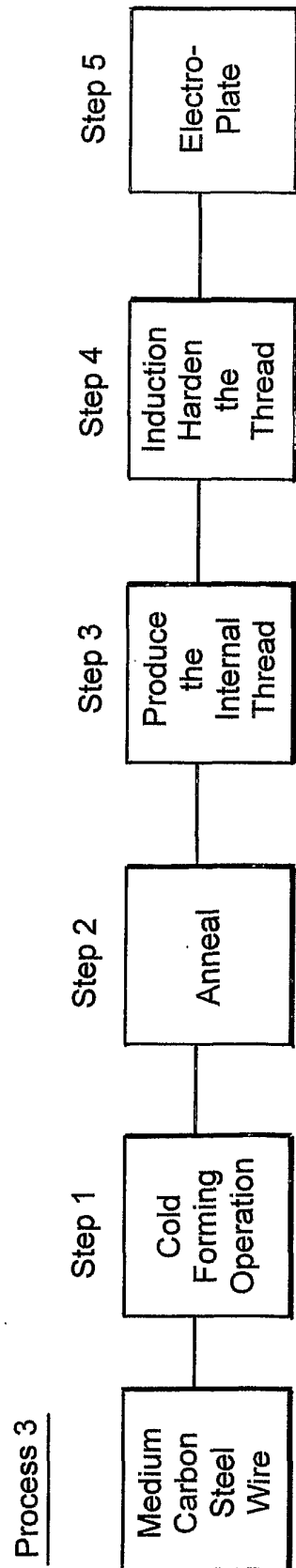
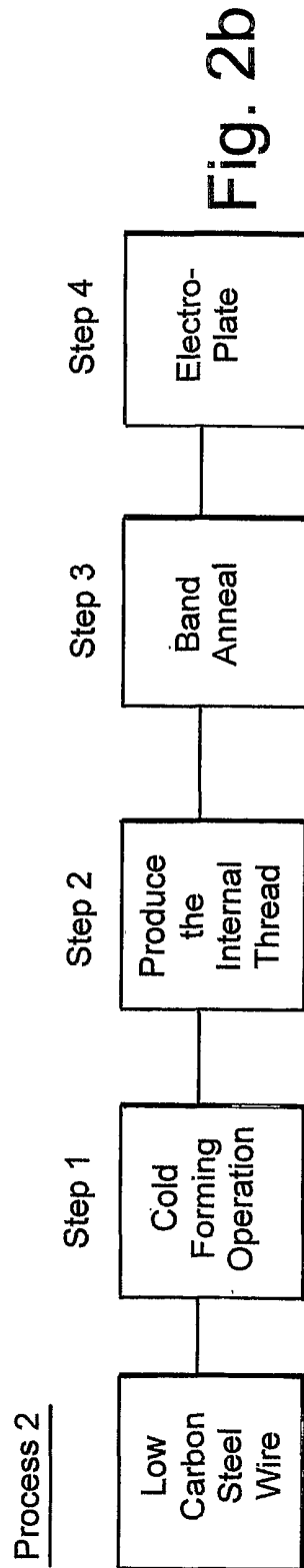
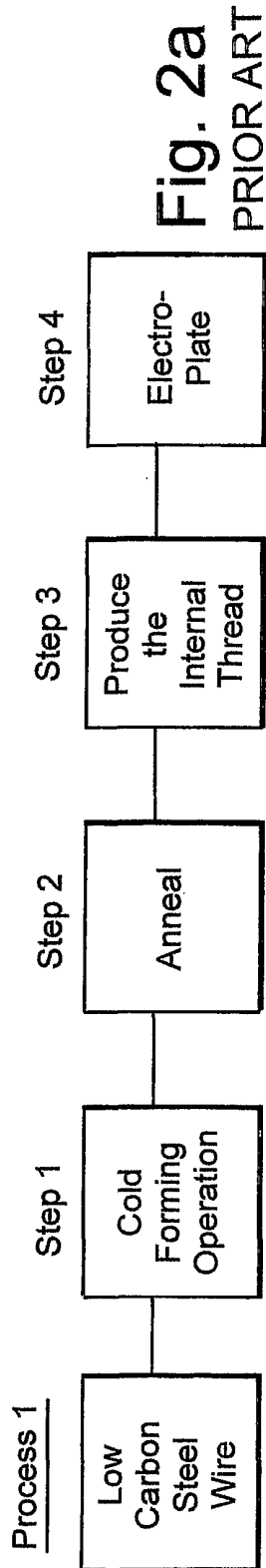

Fig. 1b



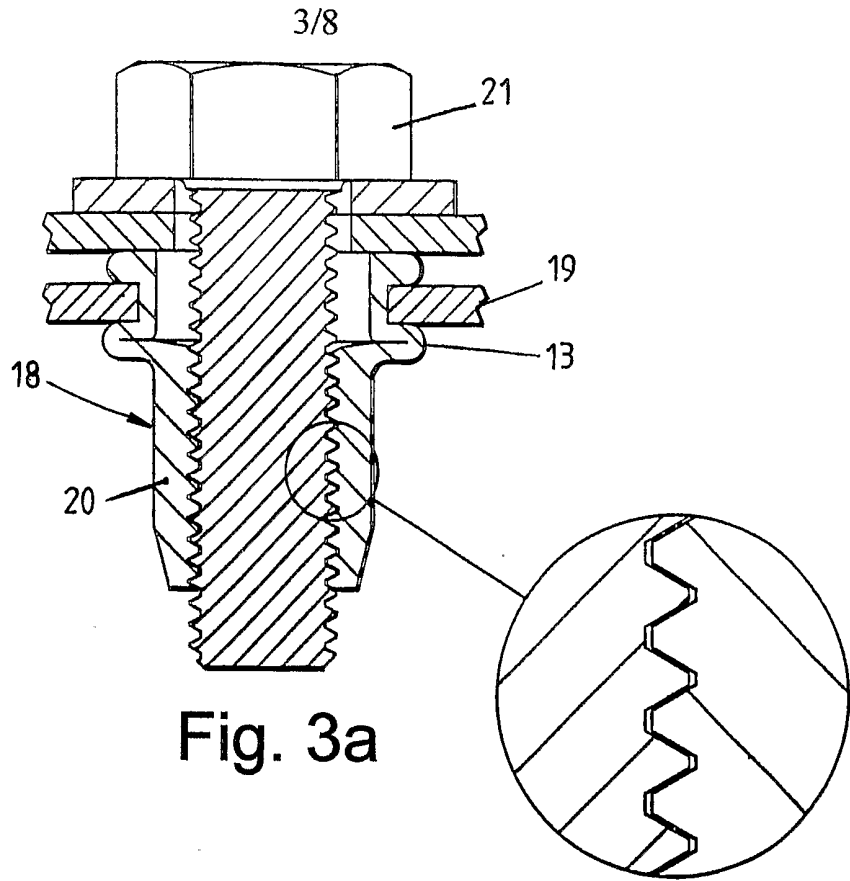

Fig. 3a

Fig. 3b

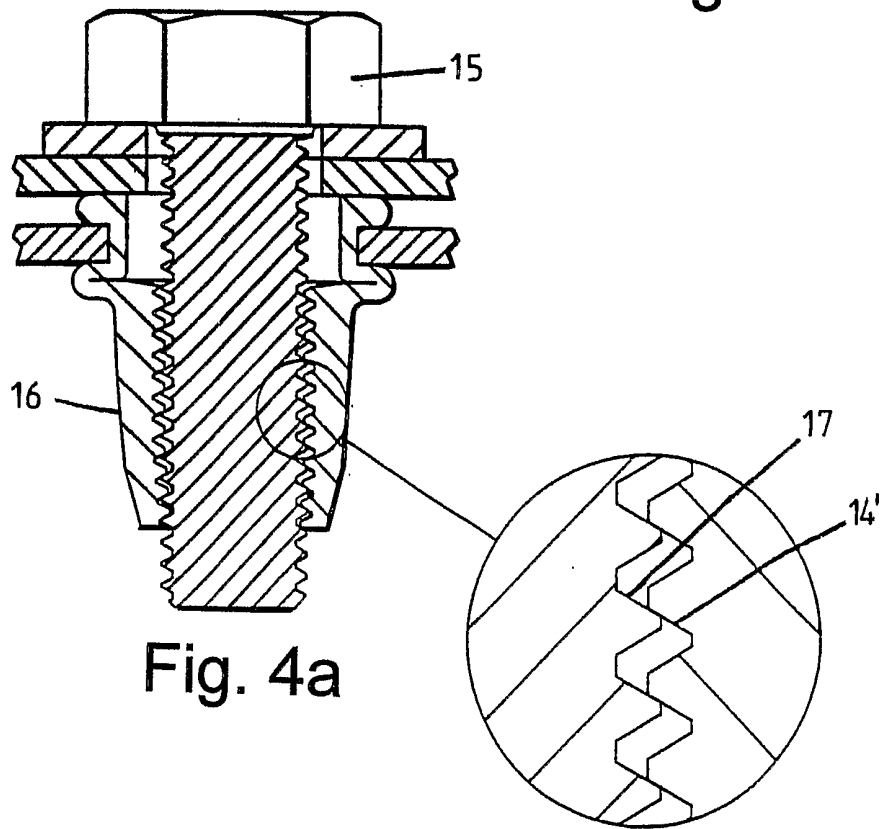

Fig. 4a

Fig. 4b

4/8

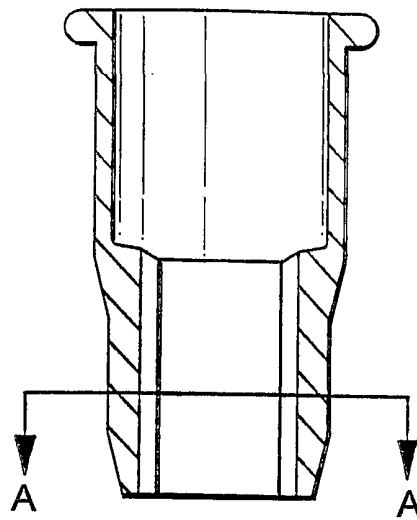

Fig. 5a

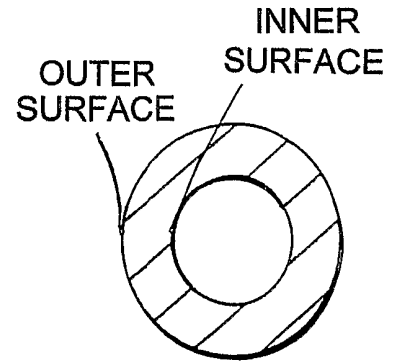

Fig. 5b

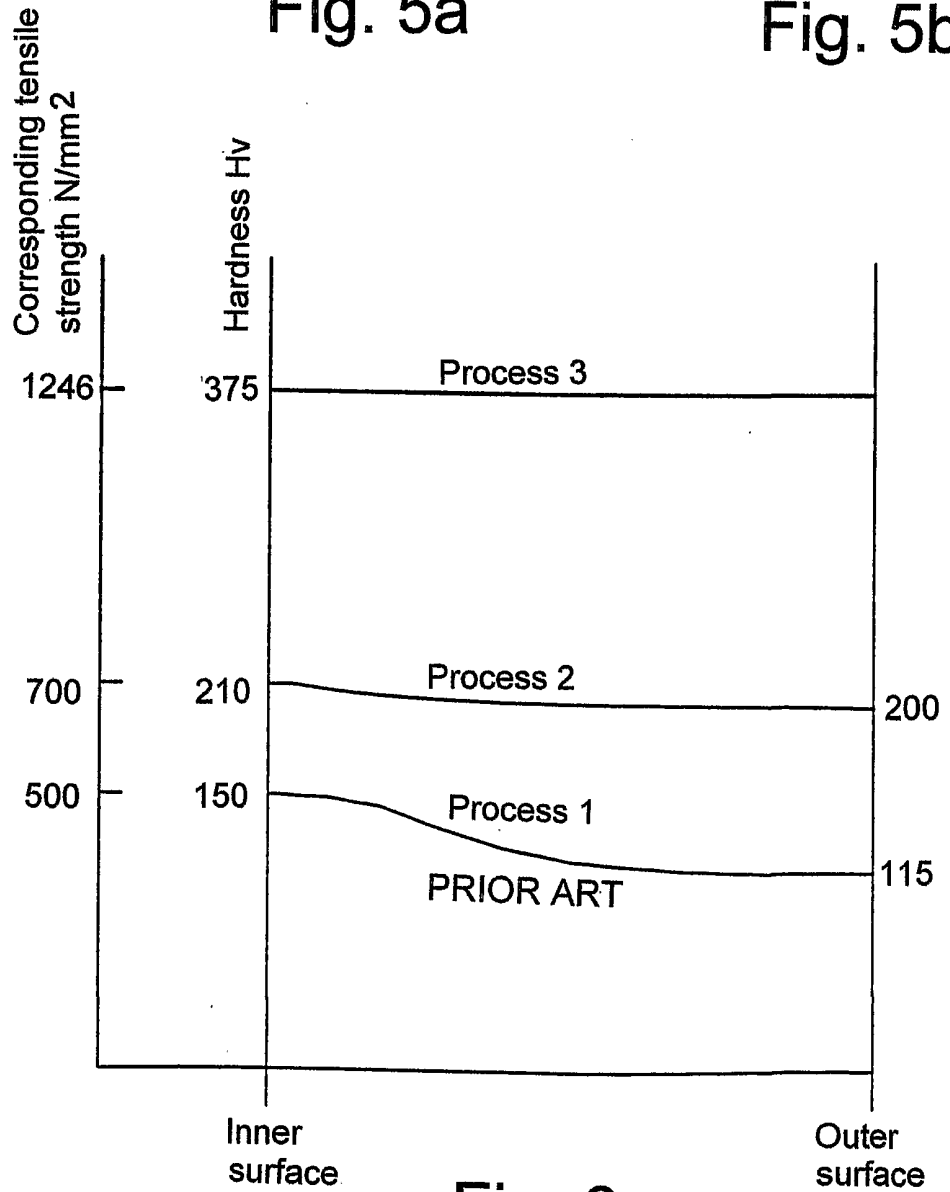

Fig. 6

5/8

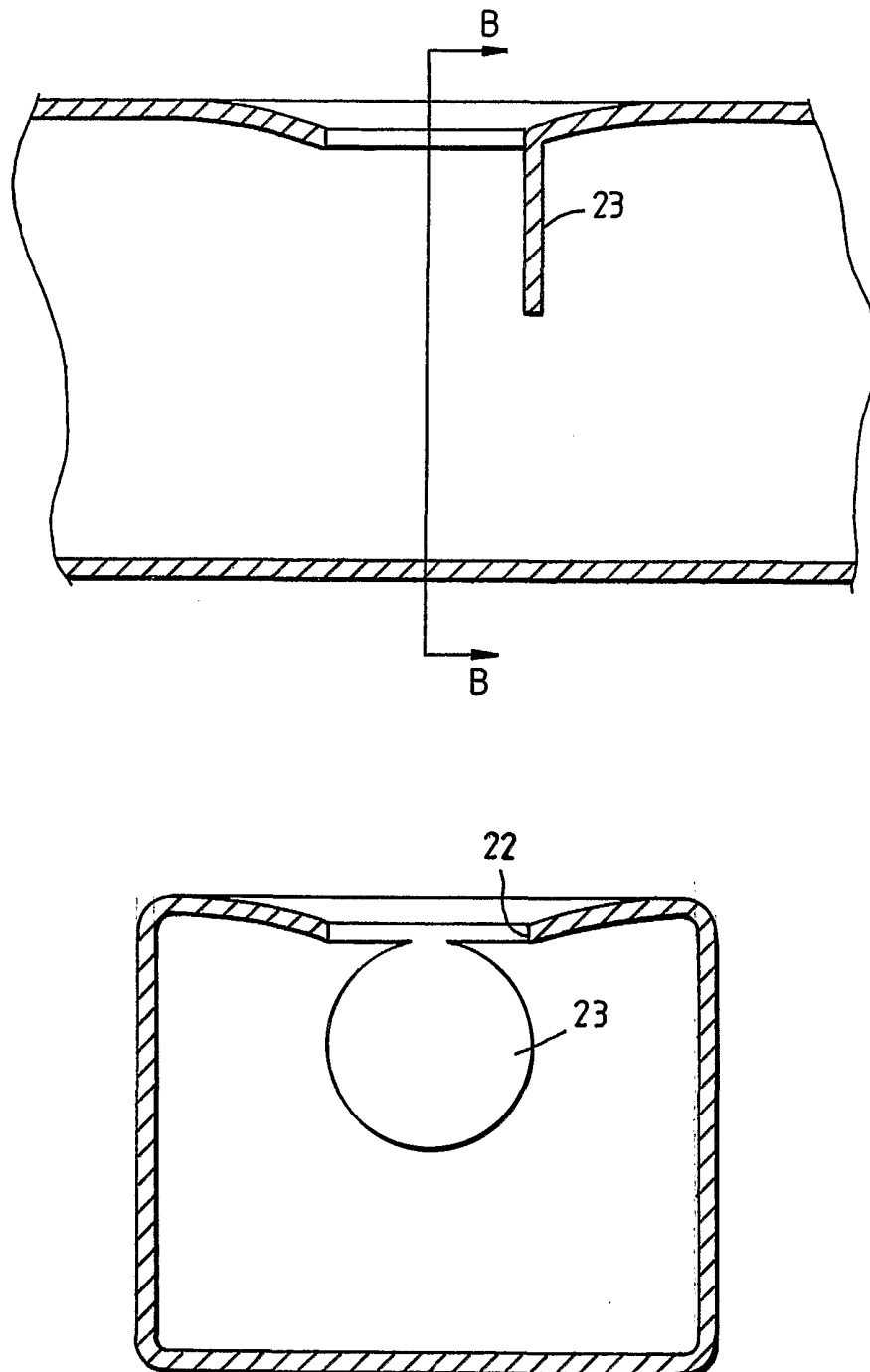

Fig. 7

6/8

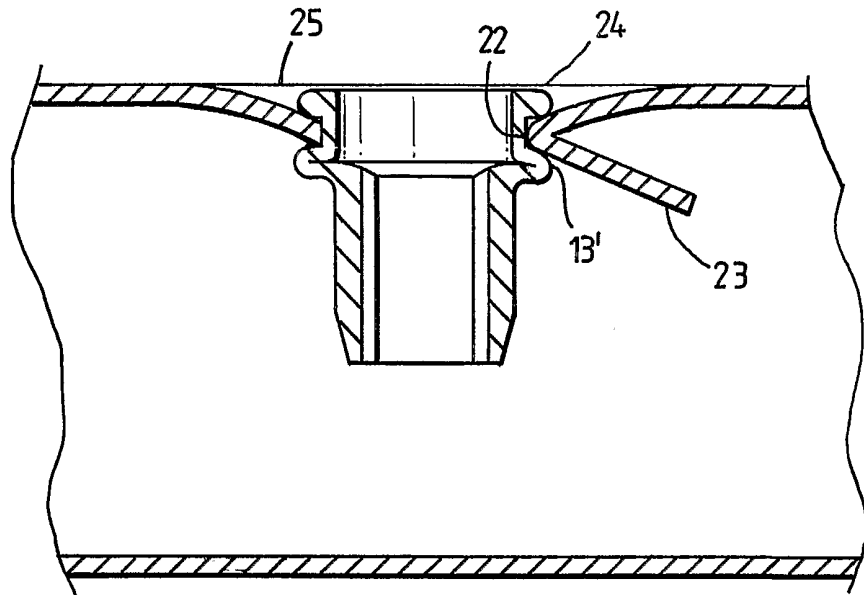

Fig. 8

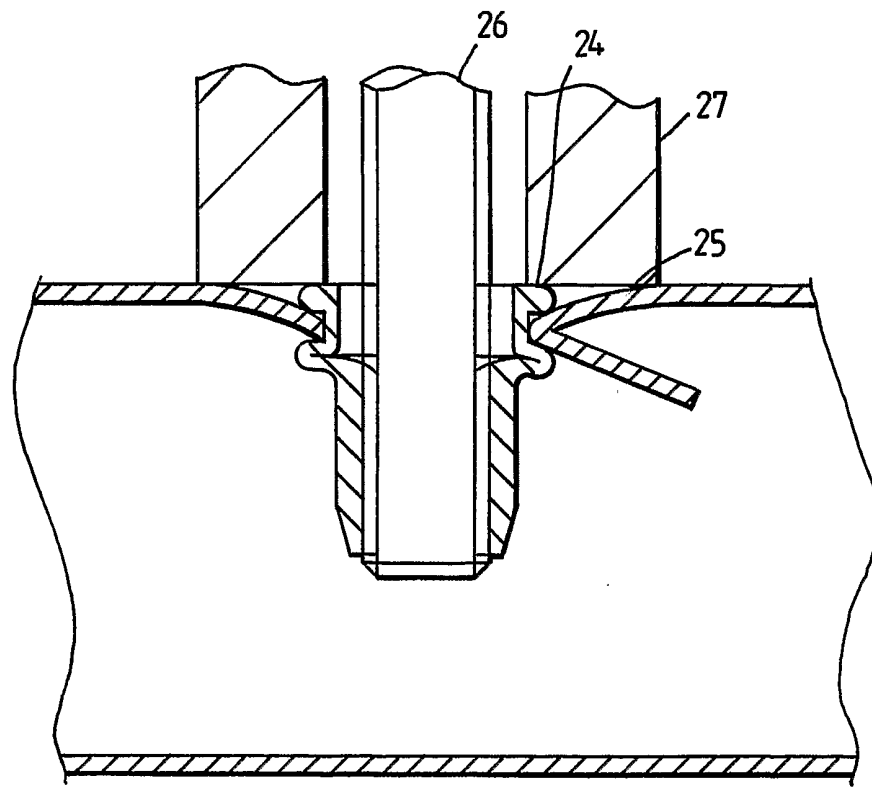

Fig. 9

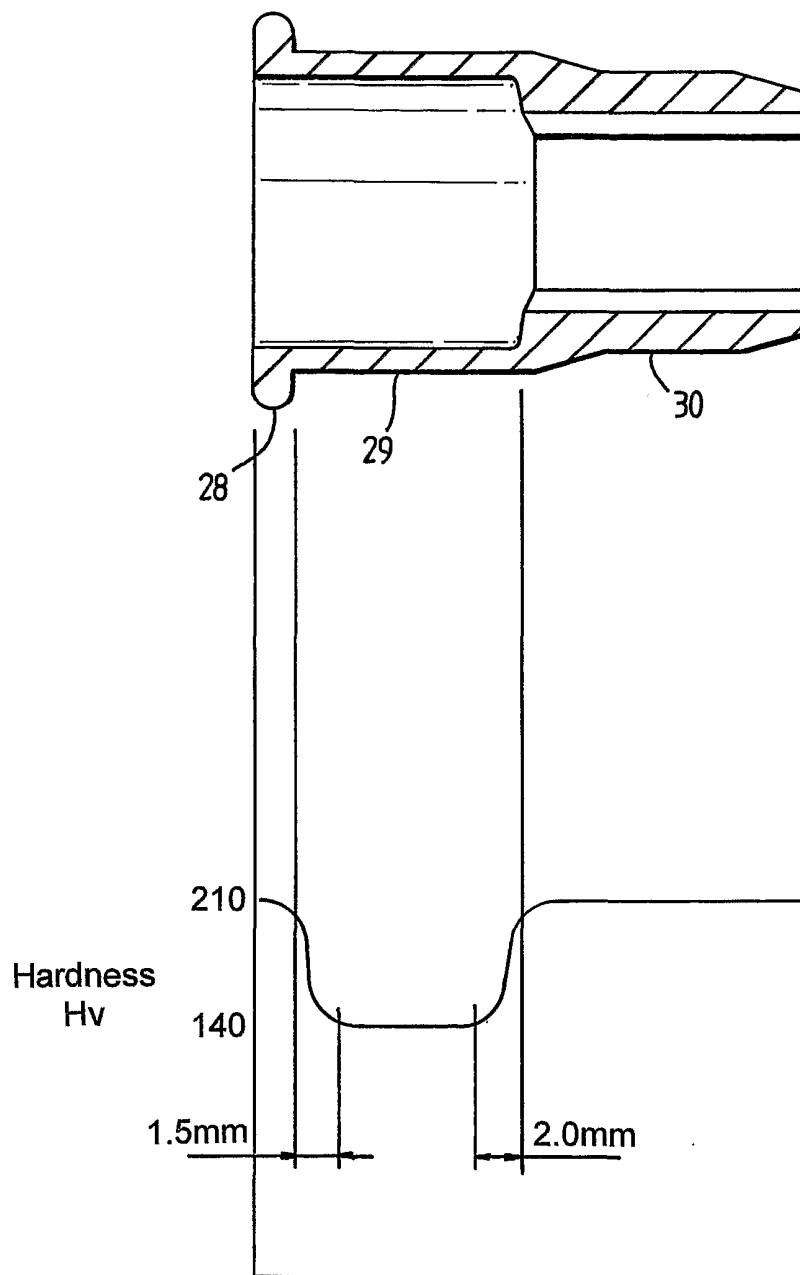

Fig. 10

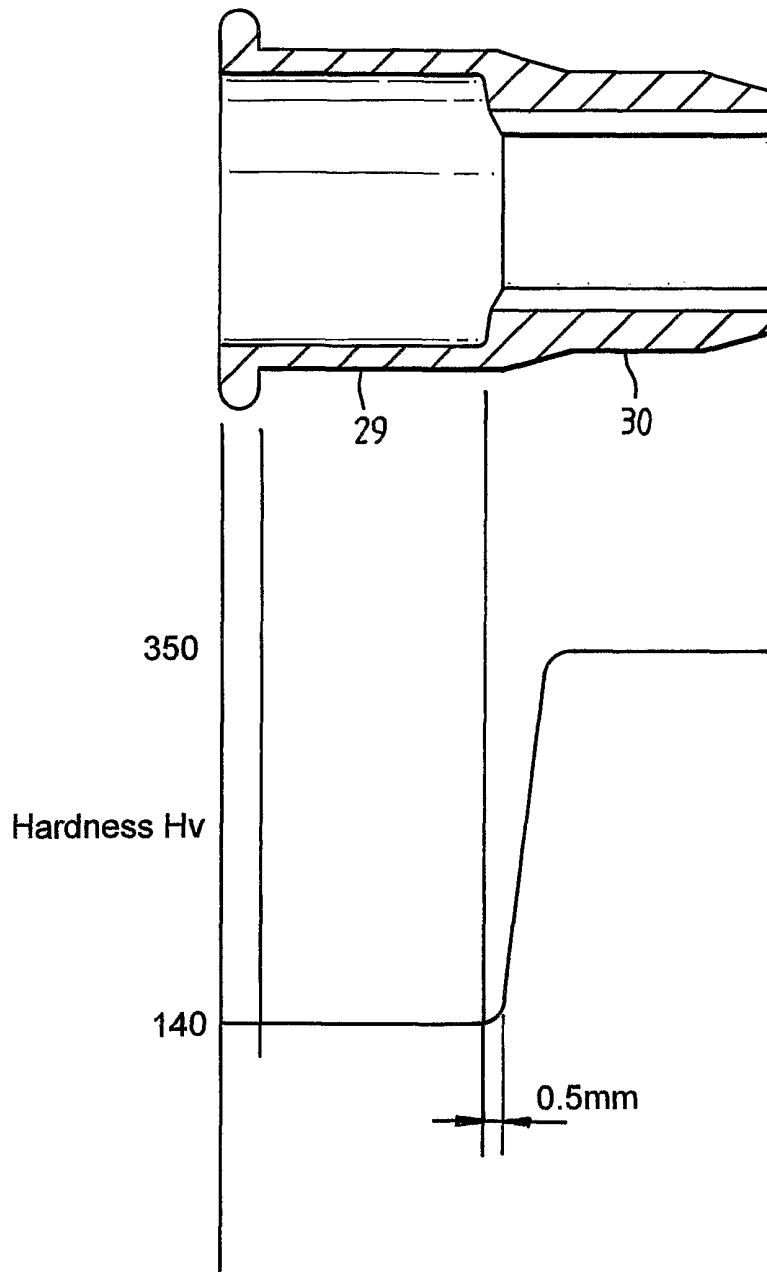

Fig. 11

INTERNATIONAL SEARCH REPORT

In **ional Application No**

PCT/GB 01/04526

A. CLASSIFICATION OF SUBJECT MATTER IPC 7 B23P15/00 F16B37/06 B21K1/60 C21D8/10				
According to International Patent Classification (IPC) or to both national classification and IPC				
B. FIELDS SEARCHED				
Minimum documentation searched (classification system followed by classification symbols) IPC 7 B23P F16B B21K C21D				
Documentation searched other than minimum documentation to the extent that such documents are included in the fields searched				
Electronic data base consulted during the international search (name of data base and, where practical, search terms used) WPI Data, EPO-Internal, PAJ				
C. DOCUMENTS CONSIDERED TO BE RELEVANT				
Category °	Citation of document, with indication, where appropriate, of the relevant passages	Relevant to claim No.		
X A	DE 27 44 547 A (SCHRUFF HERBERTS) 12 April 1979 (1979-04-12) the whole document ---	1,2,5-7, 11,12 3,4		
X	US 3 253 495 A (ORLOFF JOHN F) 31 May 1966 (1966-05-31) column 3, line 13 -column 4, line 7; figures ---	1-3,5-7, 11,12		
X A	US 2 409 352 A (GILL RAY H) 15 October 1946 (1946-10-15) column 4, line 63 -column 5, line 1; figure 3 ---	6,7,9-12 1,2,5		
--- -/--				
<input checked="" type="checkbox"/> Further documents are listed in the continuation of box C.				
<input checked="" type="checkbox"/> Patent family members are listed in annex.				
° Special categories of cited documents :				
<table style="width: 100%; border: none;"> <tr> <td style="width: 50%; border: none; vertical-align: top;"> *A* document defining the general state of the art which is not considered to be of particular relevance *E* earlier document but published on or after the international filing date *L* document which may throw doubts on priority claim(s) or which is cited to establish the publication date of another citation or other special reason (as specified) *O* document referring to an oral disclosure, use, exhibition or other means *P* document published prior to the international filing date but later than the priority date claimed </td> <td style="width: 50%; border: none; vertical-align: top;"> *T* later document published after the international filing date or priority date and not in conflict with the application but cited to understand the principle or theory underlying the invention *X* document of particular relevance; the claimed invention cannot be considered novel or cannot be considered to involve an inventive step when the document is taken alone *Y* document of particular relevance; the claimed invention cannot be considered to involve an inventive step when the document is combined with one or more other such documents, such combination being obvious to a person skilled in the art. *&* document member of the same patent family </td> </tr> </table>			*A* document defining the general state of the art which is not considered to be of particular relevance *E* earlier document but published on or after the international filing date *L* document which may throw doubts on priority claim(s) or which is cited to establish the publication date of another citation or other special reason (as specified) *O* document referring to an oral disclosure, use, exhibition or other means *P* document published prior to the international filing date but later than the priority date claimed	*T* later document published after the international filing date or priority date and not in conflict with the application but cited to understand the principle or theory underlying the invention *X* document of particular relevance; the claimed invention cannot be considered novel or cannot be considered to involve an inventive step when the document is taken alone *Y* document of particular relevance; the claimed invention cannot be considered to involve an inventive step when the document is combined with one or more other such documents, such combination being obvious to a person skilled in the art. *&* document member of the same patent family
A document defining the general state of the art which is not considered to be of particular relevance *E* earlier document but published on or after the international filing date *L* document which may throw doubts on priority claim(s) or which is cited to establish the publication date of another citation or other special reason (as specified) *O* document referring to an oral disclosure, use, exhibition or other means *P* document published prior to the international filing date but later than the priority date claimed	*T* later document published after the international filing date or priority date and not in conflict with the application but cited to understand the principle or theory underlying the invention *X* document of particular relevance; the claimed invention cannot be considered novel or cannot be considered to involve an inventive step when the document is taken alone *Y* document of particular relevance; the claimed invention cannot be considered to involve an inventive step when the document is combined with one or more other such documents, such combination being obvious to a person skilled in the art. *&* document member of the same patent family			
Date of the actual completion of the international search <p style="text-align: center;">12 December 2001</p>	Date of mailing of the international search report <p style="text-align: center;">21/12/2001</p>			
Name and mailing address of the ISA European Patent Office, P.B. 5818 Patentlaan 2 NL - 2280 HV Rijswijk Tel. (+31-70) 340-2040, Tx. 31 651 epo nl, Fax: (+31-70) 340-3016	Authorized officer <p style="text-align: center;">Plastiras, D</p>			

INTERNATIONAL SEARCH REPORT

International Application No

PCT/GB 01/04526

C.(Continuation) DOCUMENTS CONSIDERED TO BE RELEVANT

Category °	Citation of document, with indication, where appropriate, of the relevant passages	Relevant to claim No.
X	WO 00 36309 A (DENHAM KEITH ;TEXTRON FASTENING SYST LTD (GB)) 22 June 2000 (2000-06-22)	1,2,4,5, 11,12
A	page 1, line 17 - line 20 page 4, line 1 - line 2 page 4, line 14 - line 19; figure 2 ----	6,7
A	GB 1 448 977 A (TEXTRON INC) 8 September 1976 (1976-09-08) claims 11-15; figures ----	1,6,11, 12
A	EP 0 351 702 A (TEXTRON INC) 24 January 1990 (1990-01-24) column 2, line 17 - line 18; claim 9; figures ----	1,4,6, 11,12
A	EP 0 631 831 A (SCHRUFF HERBERTS) 4 January 1995 (1995-01-04) claims; figures ----	1,6,11, 12
A	US 5 603 592 A (SADRI SHAHRIAR M ET AL) 18 February 1997 (1997-02-18) column 9, line 60 -column 10, line 15; figure 1 -----	1,2,4,6, 8,11,12

INTERNATIONAL SEARCH REPORT

Information on patent family members

International Application No

PCT/GB 01/04526

Patent document cited in search report		Publication date	Patent family member(s)	Publication date
DE 2744547	A	12-04-1979	DE 2744547 A1	12-04-1979
US 3253495	A	31-05-1966	DE 1400837 A1 FR 1376325 A GB 1046239 A	07-11-1968 08-02-1965 19-10-1966
US 2409352	A	15-10-1946	CA 432954 A	
WO 0036309	A	22-06-2000	GB 2344864 A AU 1395200 A BR 9916287 A EP 1141560 A1 WO 0036309 A1	21-06-2000 03-07-2000 02-10-2001 10-10-2001 22-06-2000
GB 1448977	A	08-09-1976	NONE	
EP 0351702	A	24-01-1990	US 4869629 A AT 106502 T CA 1311379 A1 DE 68915629 D1 DE 68915629 T2 EP 0351702 A2 ES 2052827 T3 JP 2667790 B2 JP 6323316 A	26-09-1989 15-06-1994 15-12-1992 07-07-1994 15-09-1994 24-01-1990 16-07-1994 27-10-1997 25-11-1994
EP 0631831	A	04-01-1995	DE 4321174 A1 AT 165026 T DE 59405681 D1 EP 0631831 A1	05-01-1995 15-05-1998 20-05-1998 04-01-1995
US 5603592	A	18-02-1997	AT 178979 T AU 685929 B2 AU 2027995 A CA 2149621 A1 CN 1126805 A , B DE 69509031 D1 DE 69509031 T2 EP 0705986 A1 ES 2131773 T3 JP 8121443 A JP 8177837 A KR 257554 B1 US 5651649 A ZA 9504752 A	15-04-1999 29-01-1998 18-04-1996 04-04-1996 17-07-1996 20-05-1999 02-09-1999 10-04-1996 01-08-1999 14-05-1996 12-07-1996 01-06-2000 29-07-1997 08-02-1996