

G. GUNDERSEN.
 Breech-Loading Fire-Arms.

No. 145,998.

Patented Dec. 30, 1873.

Fig. 1

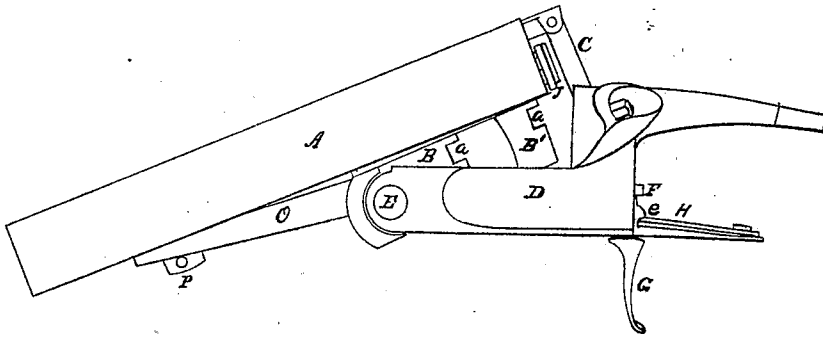

Fig. 2

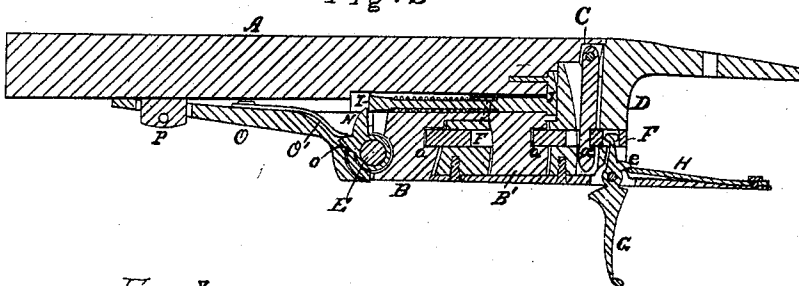

Fig. 3

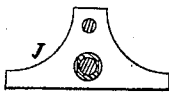
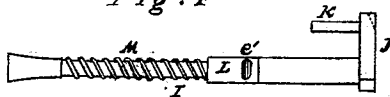

Fig. 4



WITNESSES.

James K. Hilson
 John L. Lawlor

INVENTOR.

Gunder Gunderson
 By Wiley & Warner
 Atty.

UNITED STATES PATENT OFFICE.

GUNDER GUNDERSEN, OF CHICAGO, ILLINOIS.

IMPROVEMENT IN BREECH-LOADING FIRE-ARMS.

Specification forming part of Letters Patent No. **145,998**, dated December 30, 1873; application filed August 5, 1873.

To all whom it may concern:

Be it known that I, GUNDER GUNDERSEN, of Chicago, in the county of Cook and State of Illinois, have invented certain new and useful Improvements in Breech-Loading Guns, of which improvements the following is a full, clear, and exact description, which will enable others skilled in the art to which my invention appertains to make and use the same, reference being had to the accompanying drawing forming a part of this specification, and in which—

Figure 1 is a side elevation of my improved gun when the barrels are in a position to receive the cartridges; Fig. 2, a vertical central longitudinal section of the same; Fig. 3, a vertical section through the cartridge-discharger, and Fig. 4 a side elevation of the latter.

Like letters of reference indicate like parts.

My invention relates to that class of breech-loading guns in which the barrels have a tilting movement in order to expose the breech, so that the cartridges may be inserted and the shells removed. The object of my invention is to attach the barrels more firmly to the stock, and to provide the barrels, when tilted, with an improved support; and my invention consists in certain novel features, substantially as hereinafter described, relating to the means employed for the purpose of accomplishing the objects above set forth.

In the drawing, A represents the barrels of the gun. B and B' are hooks or projections, arranged longitudinally on and extending vertically from the lower side of the barrels, and firmly attached thereto. C is a catch, pivoted to the upper part of the rear end of the upper rib or parting-strip, which projects somewhat from the rear end of the barrels, as shown. D is the breech-piece, to which the barrels are attached. The part D is mortised to receive the hooks and the catch C. E is a pin, arranged in and rigidly attached to the forward end of the part D, and extending through the mortise which receives the hook B. The hook B is cut away on its forward edge to receive the pin E, and turns on the latter as on an axle while the barrels are being tilted. The forward and rear edges of both hooks lie in the arc of a circle, of which the pin E is the center, so that they may be nicely fitted into the mor-

tises which receive them, and so as to admit of the tilting movement of the barrels. The hooks and catch C are notched on their rear edges, as shown at *a a* and *a'*. F is a bolt arranged in the part D, and extending through the mortises which receive the hooks and the catch C. The bolt F is slotted to receive the said catch and the hook B', and is arranged to engage the notches *a a* and *a'*, and thus retain the barrels in a horizontal position, as shown in Fig. 2. G is a vertical lever, pivoted to the part D, and engaging the bolt F. *e* is a shoulder on the lever G, and H is a spring, on which the shoulder *e* rests. The action of the spring H throws the upper end of the lever G forward, and the bolt F, by being engaged by this end of the lever, is held to its engagement with the hooks and with the catch C, and the barrels are thus firmly locked in a horizontal position. In order to tilt the barrels, the free end of the lever G is pushed forward until the hooks and the catch C are released by the bolt F. The barrels may then be tilted until the breech is exposed sufficiently to receive the cartridges.

I am aware that hooks corresponding to the hooks B and B' have heretofore been employed for the purpose above described; but, when only the hooks B and B' are employed for this purpose, the barrels are liable to yield to a severe lateral strain applied at their ends. This tendency I have aimed to prevent by arranging the catch C in the manner described.

I is a sliding rod, arranged longitudinally in the lower part of the lower rib or parting-strip. J is a head-plate on the rear end of the rod I. The lateral edges of the plate J are curved to correspond to the bore of each barrel, and the plate is so arranged in a rabbet in the breech as to be flush with the rear end of the barrels, and so as to be lapped by the rim of the cartridges when the latter are arranged in the barrels. K is a pin projecting from the head J into the breech, for the purpose of preventing the bar I from a rolling movement. L is a sleeve on the rod I. M is an open spiral spring arranged on the rod I, and resting against a shoulder thereon, and against the forward end of the sleeve L, as shown. The rearward movement of the sleeve L is limited by a shoulder on the rod I, and in the manner

hereinafter described. The sleeve L is grooved vertically on its sides, as represented at *e'* in Fig. 4; and, when the rod I is arranged in its recess, it is retained therein by means of screws arranged to enter the recess and the grooves *e'*. N is an arm or spur projecting rigidly from the pin E. The spur N is constructed and arranged to slightly lap the forward end of the rod I, which is slightly beveled, as shown.

When the barrels are tilted into the position shown in Fig. 1, the rod I is pushed rearward by the spur N until the latter slips from its engagement with the rod. The rod I is then thrown forward to its original position by means of the spring M. When the barrels are returned to the position shown in Fig. 2, the spur N is returned to its original position, and again laps the forward end of the bar I, the latter having sufficient vertical play to rise during the forward movement of the spur N, and to fall behind the latter after this forward movement has ceased. The rearward movement of the rod I causes the head J to push the cartridge-shells rearward until they can be readily removed from the barrels.

The forward end of the part D is curved in the arc of a circle, of which the pin E is the center, as is clearly shown in Fig. 1; and O is an arm or lever, the rear end of which is matched to the forward end of the part D. O' is a stiff spring, rigidly attached to the upper face of the lever O. *o* is a spur projecting from the pin E, and supporting the rear end of the spring O'. P is a pin projecting from the lower part of the barrels through the forward end of the lever O, which is retained in its position

by means of a small pin passed laterally through the pin P. The spring O' rests with a considerable pressure upon the spur *o*. This pressure is increased when the barrels are tilted into the position shown in Fig. 1, and the lever O thus operates as a yielding seat or support for the barrels, and prevents their forward ends from falling too suddenly or too far when the hooks B and B' and the catch C are released from their engagement with the bolt F.

It will be perceived, from the foregoing description, that I have described a double-barreled gun; but my improvements, excepting the catch C, may also be applied to a breech-loader provided with a single tilting barrel.

I do not here claim the means herein shown and described and employed for the purpose of partly ejecting the cartridge-shell from the barrel.

Having thus described my invention, what I claim as new, and desire to secure by Letters Patent, is—

1. In a breech-loading gun, the catch C, pivoted to the projecting end of the upper rib, arranged between the tilting barrels, substantially as and for the purpose specified.

2. The lever O, arranged below a tilting barrel in a breech-loading gun, and provided with the spring O', in combination with the breech-piece D, provided with the spur *o*, arranged to support the said spring, substantially as and for the purpose specified.

GUNDER GUNDERSEN.

Witnesses:

JOHN H. LAWLER,
F. F. WARNER.