



- (51) **International Patent Classification:**
B64D 11/00 (2006.01) *B64D 11/06* (2006.01)
- (21) **International Application Number:**
PCT/US2011/063265
- (22) **International Filing Date:**
5 December 2011 (05.12.2011)
- (25) **Filing Language:** English
- (26) **Publication Language:** English
- (30) **Priority Data:**
61/459,148 7 December 2010 (07.12.2010) US
- (71) **Applicant (for all designated States except US):** WEBER AIRCRAFT LLC [US/US]; 2000 Weber Drive, Gainesville, TX 76240 (US).
- (72) **Inventors; and**
- (75) **Inventors/Applicants (for US only):** WESTERINK, Rik [NL/US]; 1518 Nightingale Lane, Corinth, TX 76210 (US). TERLESKI, Timothy, W. [US/US]; 3113 Springbranch Drive, Richardson, TX 75082 (US). SKOLD, Per, Magnus [US/US]; 5917 Sidney Lane, Mckinney, TX 75070 (US). SAUCIER, Alexander, Gerard [US/US]; 15530 Lewis Place, Apt. 1717, Addison, TX 75001 (US). VALDES, Armando [MX/US]; 3232 N. Locust Street, Apt. 1428, Denton, TX 76207 (US).
- (74) **Agents:** WILLIAMS, Tiffany, L. et al.; Kilpatrick Townsend & Stockton LLP, 1100 Peachtree Street, Suite 2800, Atlanta, GA 30309 (US).
- (81) **Designated States (unless otherwise indicated, for every kind of national protection available):** AE, AG, AL, AM, AO, AT, AU, AZ, BA, BB, BG, BH, BR, BW, BY, BZ, CA, CH, CL, CN, CO, CR, CU, CZ, DE, DK, DM, DO, DZ, EC, EE, EG, ES, FI, GB, GD, GE, GH, GM, GT, HN, HR, HU, ID, IL, IN, IS, JP, KE, KG, KM, KN, KP, KR, KZ, LA, LC, LK, LR, LS, LT, LU, LY, MA, MD, ME, MG, MK, MN, MW, MX, MY, MZ, NA, NG, NI, NO, NZ, OM, PE, PG, PH, PL, PT, QA, RO, RS, RU, RW, SC, SD, SE, SG, SK, SL, SM, ST, SV, SY, TH, TJ, TM, TN, TR, TT, TZ, UA, UG, US, UZ, VC, VN, ZA, ZM, ZW.
- (84) **Designated States (unless otherwise indicated, for every kind of regional protection available):** ARIPO (BW, GH, GM, KE, LR, LS, MW, MZ, NA, RW, SD, SL, SZ, TZ, UG, ZM, ZW), Eurasian (AM, AZ, BY, KG, KZ, MD, RU, TJ, TM), European (AL, AT, BE, BG, CH, CY, CZ, DE, DK, EE, ES, FI, FR, GB, GR, HR, HU, IE, IS, IT, LT, LU, LV, MC, MK, MT, NL, NO, PL, PT, RO, RS, SE, SI, SK, SM, TR), OAPI (BF, BJ, CF, CG, CI, CM, GA, GN, GQ, GW, ML, MR, NE, SN, TD, TG).
- Published:**
— without international search report and to be republished upon receipt of that report (Rule 48.2(g))



WO 2012/078501 A2

(54) **Title:** DISPLAY ASSEMBLY WITH LIGHTING APPARATUS

(57) **Abstract:** Described are display assemblies having a display coupled to a passenger seat back, a video shroud coupled to the passenger seat back and with an inner opening positioned adjacent the display, wherein a gap is positioned between an outer edge of the display and an edge of the inner opening, and a light apparatus having at least one lighting element coupled to the passenger seat back, wherein the at least one lighting element is positioned to emit light through the gap. The display assembly may also include a diffuser coupled to the video shroud and positioned adjacent the gap.

DISPLAY ASSEMBLY WITH LIGHTING APPARATUS

CROSS REFERENCE TO RELATED APPLICATION

This application is related to and claims priority benefits from U.S. Provisional
5 Application Serial No. 61/459,148, filed on December 7, 2010, entitled MOOD LIGHTING
FOR BACK MOUNTED MONITOR. The '148 application is hereby incorporated herein in
its entirety by this reference.

FIELD OF THE INVENTION

The invention relates to passenger seats or the like.

10

BACKGROUND

Skillful application of lighting has been found to influence the experience of a viewer.
Thus, light is an element of design that may be used to provide visual comfort, as well as to
achieve emotional responses from the lighted environment. Through use of lighting patterns
of varying levels of illumination and color, it is possible to produce certain moods, such as
15 solemnity, restfulness, gaiety, activity, warmth, and coolness.

With the advent of technology in lighting devices, it is possible to achieve different
levels of light and color in a controlled and predictable manner. Lighting technology is
commonly used on many consumer devices to enhance a user's experience.

Because mood lighting is often best used in a controlled environment, aircraft or
20 vehicle cabins may provide an environment where mood lighting may enhance a passenger's
experience. Specifically, it may be desirable to incorporate mood lighting into areas that are
most often viewed by passengers, such as passenger seat backs. Many passenger seat backs
are often used to install In-Flight Entertainment ("IFE") equipment or other entertainment
devices and/or as an area for additional storage of amenities, such as reading materials or
25 other devices. Thus, it may be desirable to combine mood lighting with these amenities to
provide an overall entertaining and aesthetically pleasing environment for passengers.

SUMMARY

Embodiments of the present invention include a display assembly comprising a
display coupled to a passenger seat back, a video shroud coupled to the passenger seat back
30 and comprising an inner opening positioned adjacent the display, wherein a gap is positioned
between an outer edge of the display and an edge of the inner opening, and a light apparatus
comprising at least one lighting element coupled to the passenger seat back, wherein the at
least one lighting element is positioned to emit light through the gap. Other embodiments
may further include a passenger seat comprising the passenger seat back.

In some embodiments, the lighting element comprises at least one light source that is configured to direct light toward a passenger's lap. At least one of color, intensity, or pattern of light emitted from the lighting element may be adjustable. In other embodiments, a controller may be connected to the lighting element, which is configured to adjust at least one
5 of color, intensity, or pattern of light emitted from the lighting element. The color, intensity, or pattern of light emitted from the lighting element may be adjusted based on detection of unsafe conditions.

In some embodiments, the display assembly may further comprise a diffuser coupled to the video shroud and positioned adjacent the gap. The diffuser may be translucent, as well
10 as colored.

BRIEF DESCRIPTION OF THE DRAWINGS

Figure 1 is a perspective view of a display assembly according to certain embodiments of the present invention.

Figure 2 is a front view of the display assembly of Figure 1.

Figure 3 is a perspective view of the display assembly of Figure 1 emitting an
15 alternate color.

Figure 4 is a perspective view of the display assembly of Figure 1 emitting another alternate color.

Figure 5 is a perspective view of the display assembly of Figure 1 emitting yet
20 another alternate color.

DETAILED DESCRIPTION

The described embodiments of the invention provide display assemblies for use with passenger seats. While the display assemblies are discussed for use with aircraft seats, they are by no means so limited. Rather, embodiments of the display assemblies may be used in
25 passenger seats or other seats of any type or otherwise as desired.

Figures 1-5 illustrate embodiments of a display assembly 10. In these embodiments, the display assembly 10 comprises a display 12, a video shroud 14, and a light apparatus 16.

The display 12 may be a display for an IFE or other entertainment devices. In some embodiments, the display 12 is coupled to a back 18 of a passenger seat 20. One of ordinary
30 skill in the relevant art will understand that any suitable coupling technique may be used to attach the display 12 to the back 18 including but not limited to mechanical fasteners such as screws, bolts, rivets, compression fit, or other suitable fasteners.

The display 12 may comprise any suitable outer perimeter shape 22 including but not limited to square, rectilinear, trapezoidal, parabolic, or other suitable shape that does not

exceed an outer perimeter 28 of the back 18. In certain embodiments, the back 18 may include a recess that is shaped to accommodate the outer perimeter shape 22 of the display 12 and at least a portion of a depth of the display 12.

As shown in Figures 1-5, embodiments of the video shroud 14 may be coupled to the back 18. One of ordinary skill in the relevant art will understand that any suitable coupling technique may be used to attach the video shroud 14 to the back 18 including but not limited to mechanical fasteners such as screws, bolts, rivets, compression fit, or other suitable fasteners. The video shroud 14 may include a surface 24 having an outer perimeter shape 26 that corresponds to at least a portion of the outer perimeter 28 of the back 18. The video shroud 14 includes sides 30 that are shaped so that the surface 24 of the video shroud 14 is positioned adjacent and/or aft of the display 12.

The video shroud 14 may be formed of a material that resists stains and is easily and quickly sanitized between passenger uses including but not limited to plastics, such as polycarbonate, polyethylene, polypropylene, polyvinyl chloride, or other similar plastics, metallic materials, composite materials, or other similar materials.

The video shroud 14 may also comprise an inner opening 32. The inner opening 32 may be shaped so that the display 12 is visible through the video shroud 14. Thus, as shown in Figures 1-5, the inner opening 32 may have any suitable shape that substantially surrounds the display 12. In some embodiments, the inner opening 32 may be larger than the outer perimeter shape 22 of the display 12 so that a gap 36 is positioned between an outer edge 38 of the display 12 and an edge 40 of the inner opening 32.

Embodiments of the light apparatus 16 may be coupled to the back 18, the display 12, and/or the video shroud 14. For example, in the embodiments shown in Figures 1-5, the light apparatus 16 may include at least one lighting element 34 that may be coupled to the back 18 adjacent the display 12, behind the display 12, and/or behind the video shroud 14. The lighting element 34 may include at least one conventional light source and/or light emitting diode ("LED"), such as single-die or multi-die LEDs, organic LEDs, white LEDs, and color or multicolor LEDs.

The light apparatus 16 may also include a diffuser 42 that is positioned adjacent the lighting element 34. The diffuser 42 may be formed of a translucent material, wherein the translucent may be clear, white, colored, or any combination thereof. One of ordinary skill in the relevant art will understand that the diffuser 42 may be formed of any suitable plastic or glass material that allows the light emitted from the lighting element 34 to be visible by the passenger in an aesthetically pleasing manner.

In the embodiments where the lighting element 34 is positioned adjacent the display 12, the diffuser 42 may be shaped to substantially surround at least the outer edge 38 of the display 12. In some embodiments, the diffuser 42 may also have a width that spans the gap 36 between the display 12 and the inner opening 32 of the video shroud 14. In the
5 embodiments where the lighting element 34 is positioned behind the display 12, a portion of the display 12 itself may be formed of a translucent material so that a separate diffuser 42 is not required (i.e., the diffuser 42 is integrated into the display 12) or the light emitted from the lighting element 34 may be reflected around the edges of the display 12. In the
10 embodiments where the lighting element 34 is positioned behind the video shroud 14, the video shroud 14 may be formed of a translucent material so that a separate diffuser 42 is not required (i.e., the diffuser 42 is integrated into the video shroud 14) or the light emitted from the lighting element 34 may be reflected around the edges of the video shroud 14. Incorporating light around the display 12 may enhance a passenger's enjoyment and/or may make the display 12 easier to view.

15 One of ordinary skill in the relevant art will understand that any suitable coupling arrangement may be used to attach the diffuser 42 to the display 12 and/or the video shroud 14 including but not limited to mechanical fasteners such as screws, bolts, rivets, compression fit, chemical fasteners, or other suitable fasteners.

In certain embodiments, as shown in Figures 1-5, the lighting element 34 may be
20 powered by the IFE system or may have a separate source of power. The output of the lighting element 34 may be adjusted with a controller 44, which is electronically connected to the lighting element 34 so that an output from the controller 44 adjusts the lighting element 34. Thus, as illustrated in Figures 1-5, the controller 44 may be used to change the light color and/or intensity and/or create patterns in the light emission (i.e., blinking, flashing) to convey
25 different moods and atmospheres to passengers. The controller 44 may be configured to adjust each lighting element 34 individually, by group of elements within individual passenger seat 20, by individual passenger seat 20 or in groups based on rows, sections, or an entire aircraft or vehicle.

In some embodiments, the controller 44 may be configured to adjust the lighting
30 element 34 based on manual input from passengers or personnel. The controller 44 may be positioned within the back 18 and/or the video shroud 14 (as shown in Figure 2) or may be incorporated as a touch screen within the display 12 (as shown in Figure 1) for the passenger's use and/or may be positioned within the aircraft or vehicle in a location convenient for use by aircraft or vehicle personnel or operator.

Additionally or alternatively, the controller 44 may be configured to operate the lighting element 34 as a communication tool based on signals received from the aircraft or vehicle control system. For example, the controller 44 may be used to change the light color and/or intensity and create patterns in the light emission (i.e., blinking, flashing) based on various events occurring during transport (such as takeoff, cruising altitude, beverage service, meals, landing, etc.), activities within the aircraft or vehicle (sleeping, reading, watching a movie, etc.) and/or the presence of unsafe conditions (turbulence, improper use of electronic devices, seat backs not upright, tray tables not stowed, etc.). One of ordinary skill in the relevant art will understand that these are but a few examples of how the lighting apparatus 16 may be configured as a communication tool.

In certain embodiments, the light apparatus 16 may also be configured as a reading light by adjusting the light apparatus 16 to direct light toward a passenger's lap. In these embodiments, the lighting element 34 and/or the diffuser 42 may be pivotally coupled to the back 18, the display 12, or the video shroud 14 so that a passenger may adjust the direction of the light emitted by the light apparatus 16. The lighting element 34 may also include at least one light source and/or LED that is configured to direct light toward a passenger's lap, so that the light source and/or LED illuminates when a passenger actuates the reading light switch. In other embodiments, the light source and/or LED may be surrounded by an adjustable diffuser 42 that automatically rotates to direct light toward a passenger's lap when a passenger actuates the reading light switch.

The foregoing is provided for purposes of illustrating, explaining, and describing embodiments of the present invention. Further modifications and adaptations to these embodiments will be apparent to those skilled in the art and may be made without departing from the scope or spirit of the invention.

CLAIMS

That which is claimed is:

- 5 1. A display assembly comprising:
- (a) a display coupled to a passenger seat back;
 - (b) a video shroud coupled to the passenger seat back and comprising an inner opening positioned adjacent the display, wherein a gap is positioned between an outer edge of the display and an edge of the inner opening; and
 - 10 (c) a light apparatus comprising at least one lighting element coupled to the passenger seat back, wherein the at least one lighting element is positioned to emit light through the gap.
2. The display assembly of claim 1, wherein the at least one lighting element comprises
15 at least one light source that is configured to direct light toward a passenger's lap.
3. The display assembly of claim 1, wherein at least one of color, intensity, or pattern of light emitted from the at least one lighting element is adjustable.
- 20 4. The display assembly of claim 3, wherein the at least one of color, intensity, or pattern of light emitted from the at least one lighting element is adjusted based on detection of unsafe conditions.
5. The display assembly of claim 1, further comprising a controller connected to the at
25 least one lighting element, which is configured to adjust at least one of color, intensity, or pattern of light emitted from the at least one lighting element.
6. The display assembly of claim 5, wherein the at least one of color, intensity, or pattern
of light emitted from the at least one lighting element is adjusted based on detection of unsafe
30 conditions.
7. A passenger seat comprising:
- (a) a passenger seat back; and
 - (b) a display assembly comprising:

- (i) a display coupled to the passenger seat back;
 - (ii) a video shroud coupled to the passenger seat back and comprising an inner opening positioned adjacent the display, wherein a gap is positioned between an outer edge of the display and an edge of the inner opening; and
 - 5 (iii) a light apparatus comprising at least one lighting element coupled to the passenger seat back, wherein the at least one lighting element is positioned to emit light through the gap.
- 8. The passenger seat of claim 7, wherein the at least one lighting element comprises at least one light source that is configured to direct light toward a passenger's lap.
- 10 9. The passenger seat of claim 7, wherein at least one of color, intensity, or pattern of light emitted from the at least one lighting element is adjustable.
- 15 10. The passenger seat of claim 9, wherein the at least one of color, intensity, or pattern of light emitted from the at least one lighting element is adjusted based on detection of unsafe conditions.
- 20 11. The passenger seat of claim 7, further comprising a controller connected to the at least one lighting element, which is configured to adjust at least one of color, intensity, or pattern of light emitted from the at least one lighting element.
- 25 12. The passenger seat of claim 11, wherein the at least one of color, intensity, or pattern of light emitted from the at least one lighting element is adjusted based on detection of unsafe conditions.
- 13. A display assembly comprising:
 - (a) a display coupled to a passenger seat back;
 - (b) a video shroud coupled to the passenger seat back and comprising an inner opening positioned adjacent the display, wherein a gap is positioned between an outer edge of the display and an edge of the inner opening; and
 - (c) a light apparatus comprising:
 - 30 (i) at least one lighting element coupled to the passenger seat back, wherein the at least one lighting element is positioned to emit light through the gap; and

(ii) a diffuser coupled to the video shroud and positioned adjacent the gap.

14. The display assembly of claim 13, wherein the at least one lighting element comprises at least one light source that is configured to direct light toward a passenger's lap.

5

15. The display assembly of claim 13, wherein at least one of color, intensity, or pattern of light emitted from the at least one lighting element is adjustable.

10

16. The display assembly of claim 15, wherein the at least one of color, intensity, or pattern of light emitted from the at least one lighting element is adjusted based on detection of unsafe conditions.

15

17. The display assembly of claim 13, further comprising a controller connected to the at least one lighting element, which is configured to adjust at least one of color, intensity, or pattern of light emitted from the at least one lighting element.

20

18. The display assembly of claim 17, wherein the at least one of color, intensity, or pattern of light emitted from the at least one lighting element is adjusted based on detection of unsafe conditions.

19. The display assembly of claim 13, wherein the diffuser is translucent.

20. The display assembly of claim 19, wherein the diffuser is colored.

1/3

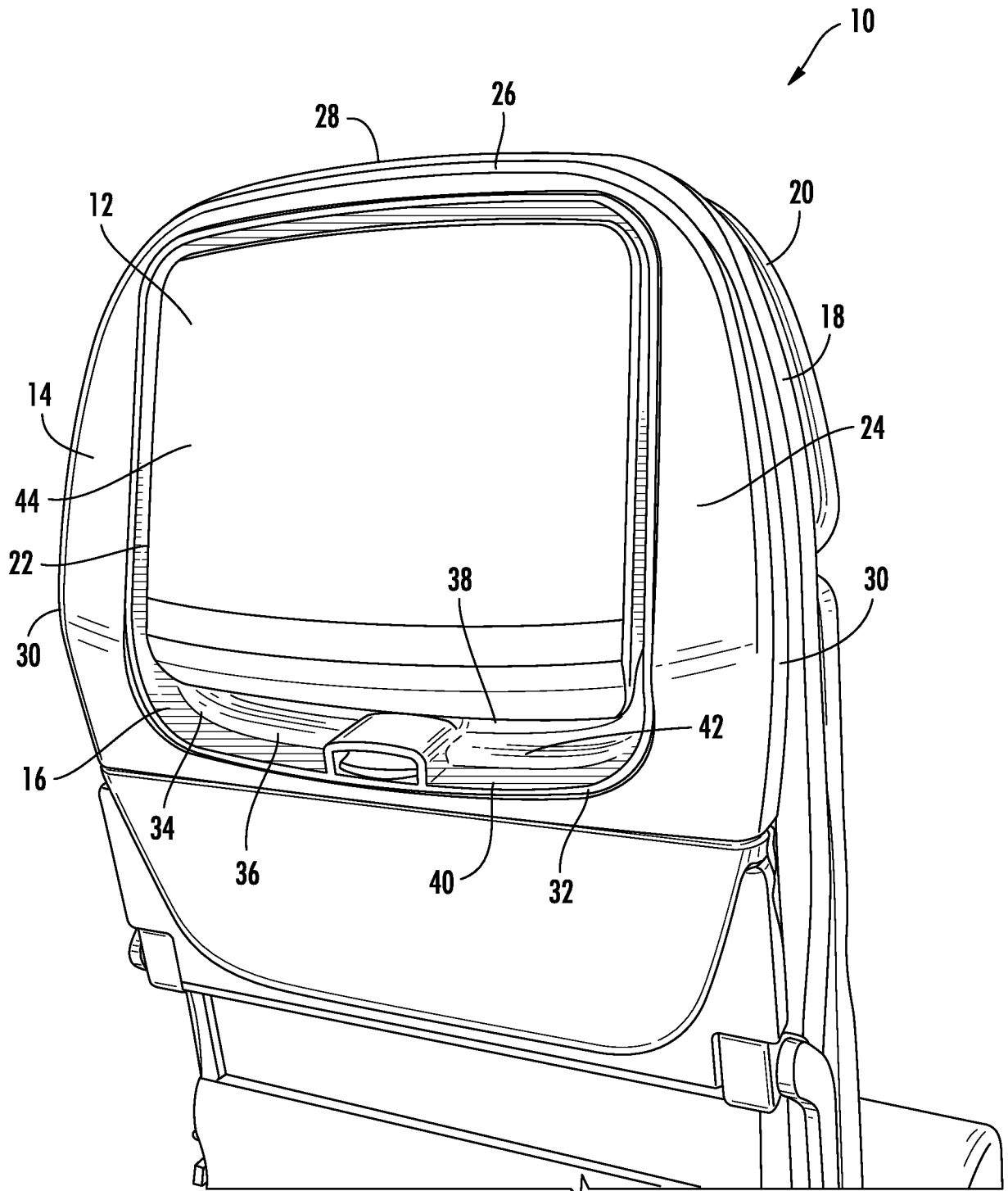

FIG. 1

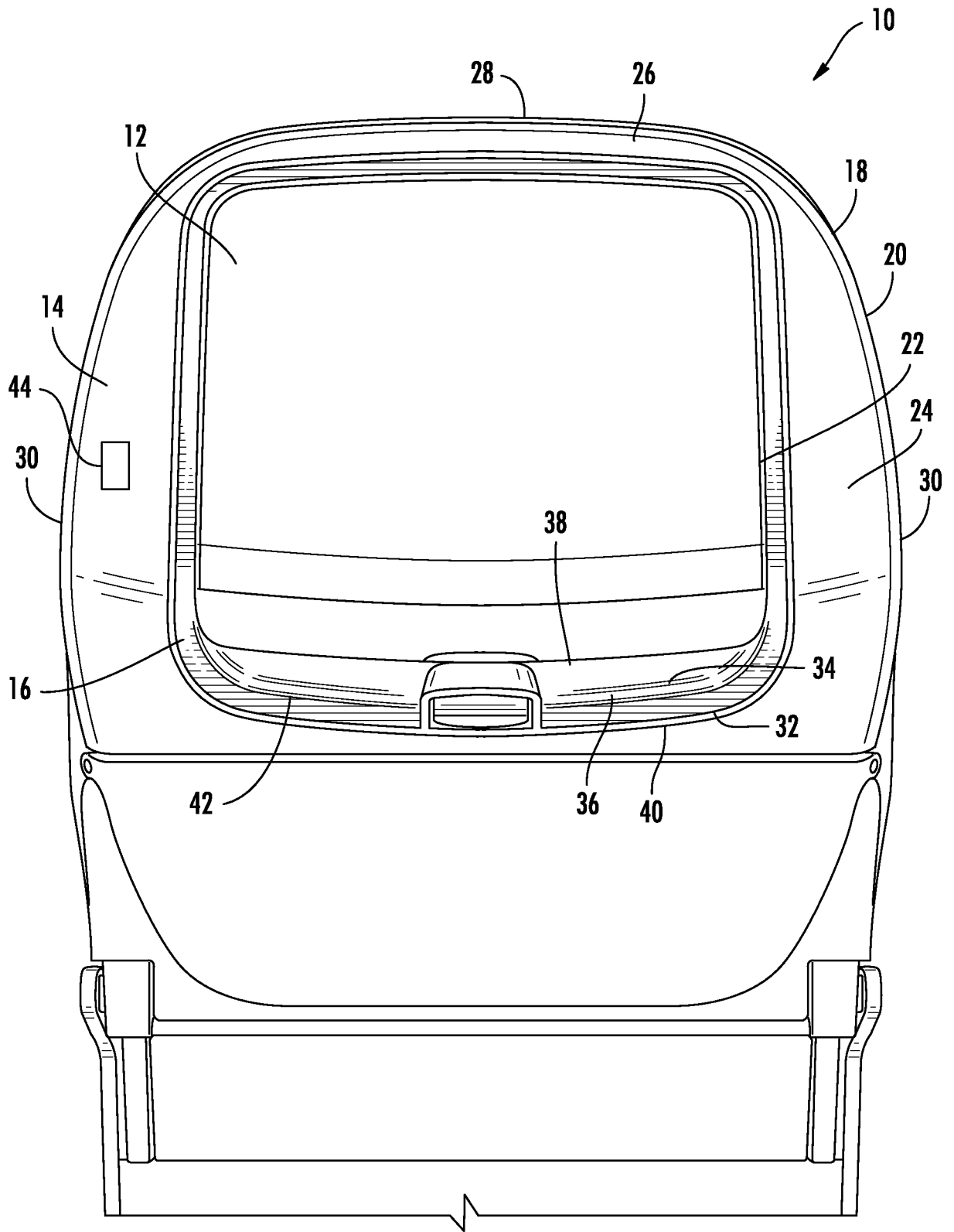

FIG. 2

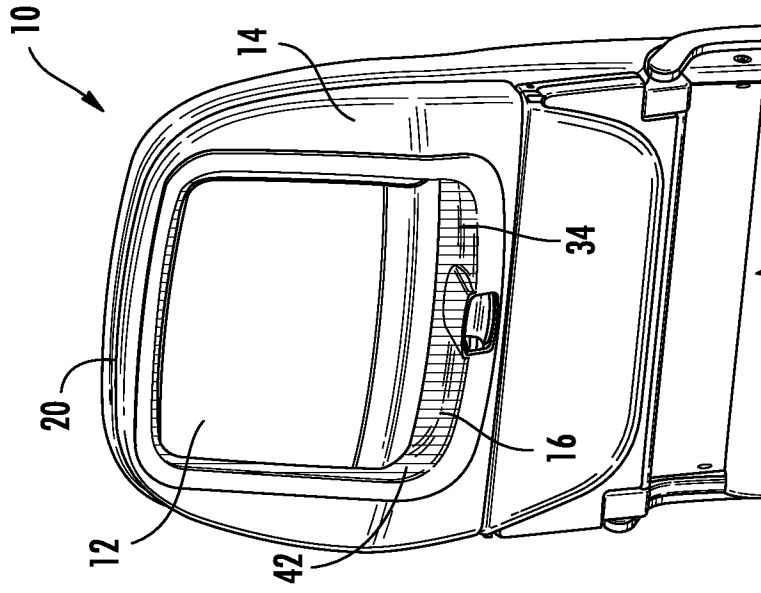

FIG. 3

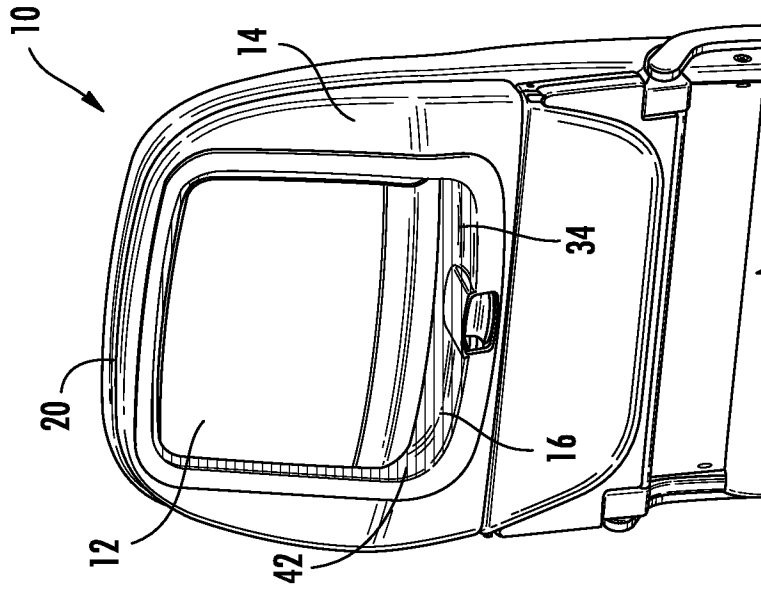

FIG. 4

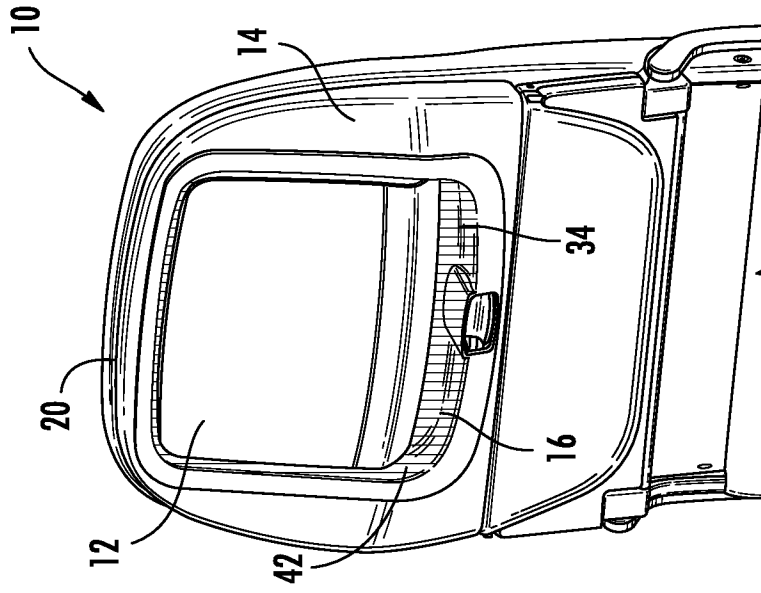

FIG. 5