

(No Model.)

3 Sheets—Sheet 1.

G. JOHNSON, Jr.

MACHINE FOR MAKING TONGUE AND GROOVE FLOORING.

No. 393,238.

Patented Nov. 20, 1888.

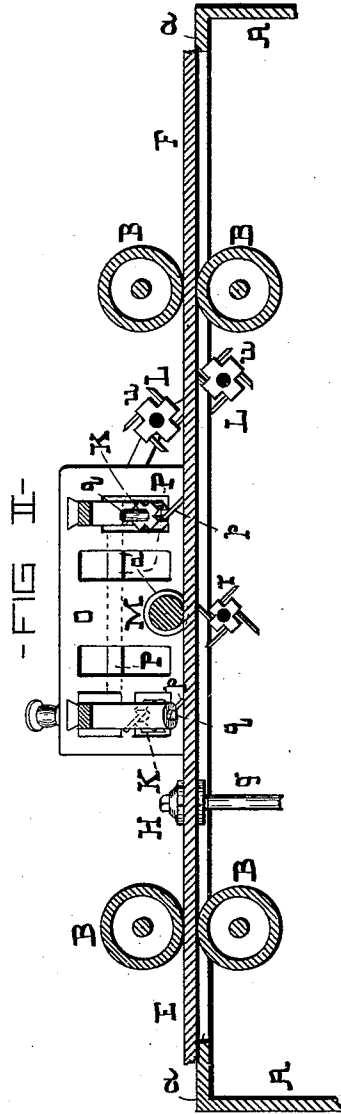
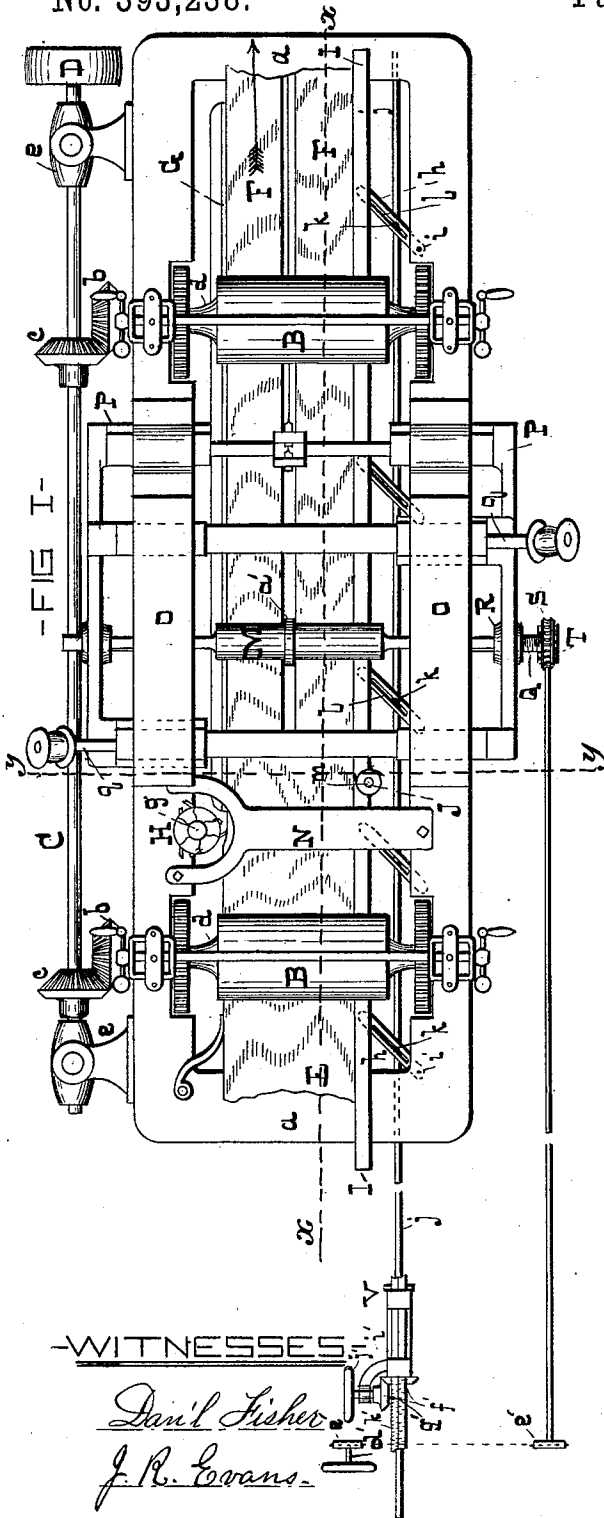

-WITNESSES-

David Fisher
J. R. Evans.

-INVENTOR-

G. Johnson Jr.,
by G. H. Howard,
att'y.

(No Model.)

3 Sheets—Sheet 2.

G. JOHNSON, Jr.

MACHINE FOR MAKING TONGUE AND GROOVE FLOORING.

No. 393,238.

Patented Nov. 20, 1888.

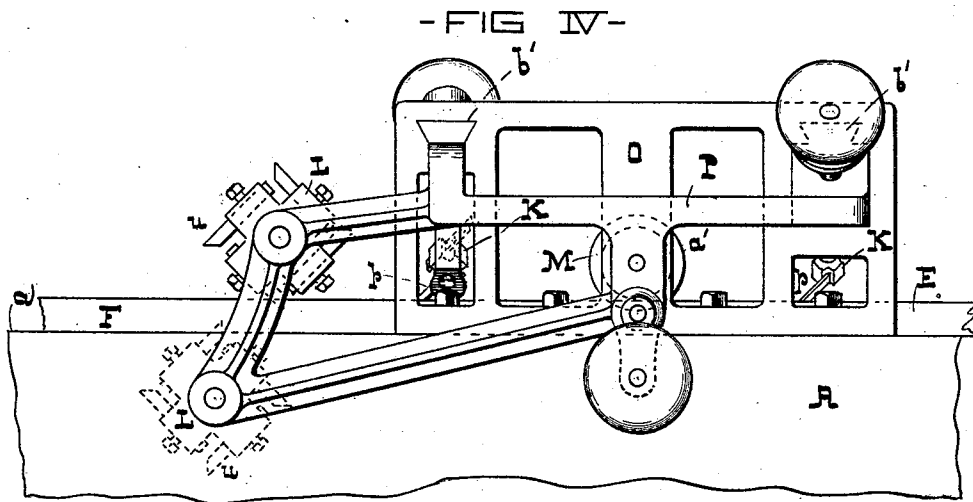
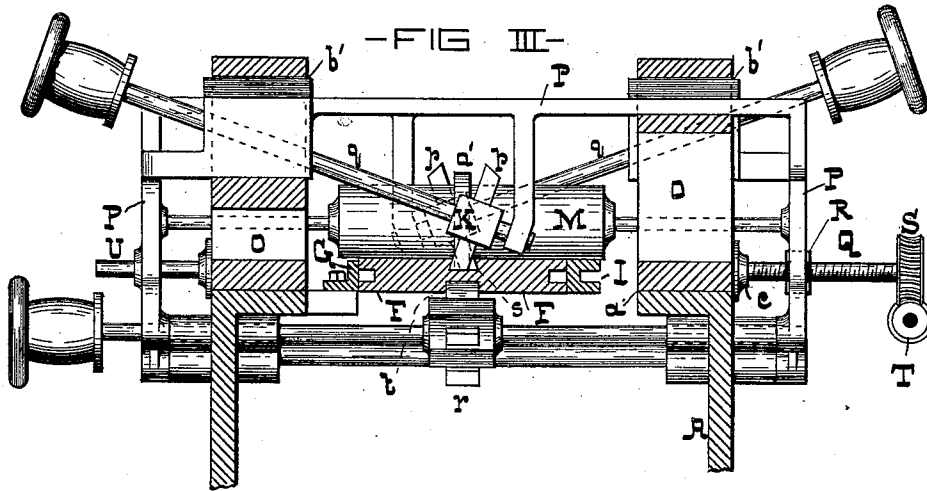

-WITNESSES-

Dan'l. Fisher
J. R. Evans

-INVENTOR-

Gunter Johnson Jr.,
by G. W. Howard,
Atty.

G. JOHNSON, Jr.

MACHINE FOR MAKING TONGUE AND GROOVE FLOORING.

No. 393,238.

Patented Nov. 20, 1888.

-FIG V-

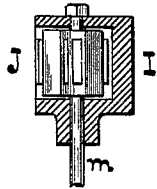
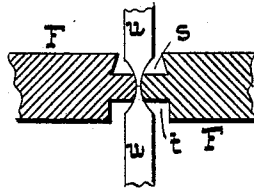
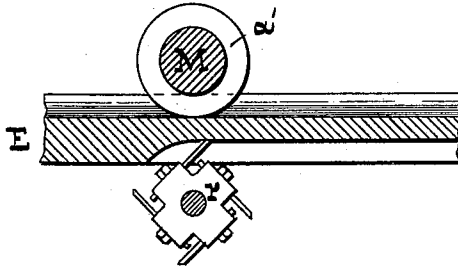

FIG VI-



-FIG VII-



-FIG VIII-

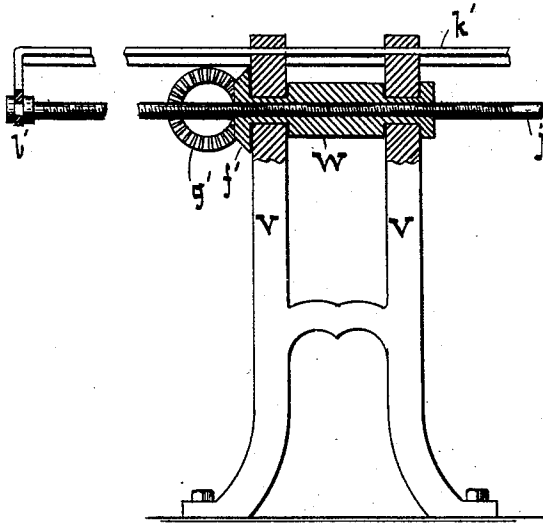

-FIG IX-

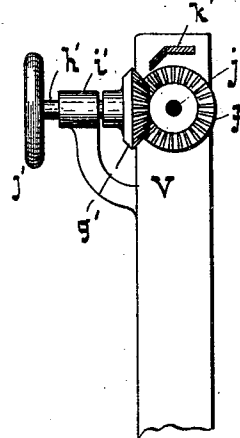

-WITNESSES -

Dan'l Fisher
J. R. Evans.

-INVENTOR-

Greenleaf Johnson Jr.,
by G. H. H. Howard,
att'y.

UNITED STATES PATENT OFFICE.

GREENLEAF JOHNSON, JR., OF BALTIMORE, MARYLAND.

MACHINE FOR MAKING TONGUE-AND-GROOVE FLOORING.

SPECIFICATION forming part of Letters Patent No. 393,238, dated November 20, 1888.

Application filed February 6, 1888. Serial No. 263,120. (No model.)

To all whom it may concern:

Be it known that I, GREENLEAF JOHNSON, Jr., of the city of Baltimore and State of Maryland, have invented certain Improvements in Machines for Making Tongue-and-Groove Flooring, of which the following is a specification.

This invention relates to an improved machine by means of which at one operation a plank is edged and the said edges grooved and the plank channeled at both sides and separated centrally of the channel, so as to produce two tongued and grooved boards, which may be planed at one or both sides or left rough, as may be desired.

In the further description of the said invention which follows reference is made to the accompanying drawings, forming a part hereof, and in which—

Figure I is a top or plan view of the improved machine, and Fig. II a longitudinal section of Fig. I, taken on the dotted line *x x*. Fig. III is a transverse section taken on the dotted line *y y*, Fig. I, and shown on an enlarged scale. Fig. IV is an exterior side view of a part of the machine, also enlarged. Figs. V, VI, VII, VIII, and IX are details of the machine as hereinafter described.

Similar letters of reference indicate similar parts in all the views.

In the said drawings, A is the frame of the machine, and its upper surface, which is the bed on which the plank rests, is denoted by *a*. The machine is provided with the usual feeding-rolls, two pairs only of which are shown, and denoted by B. These rolls are preferably driven by means of beveled gears *b* and *c*, the former being secured to the spindles *d* of the rolls B and the latter to the shaft C, adapted to be revolved in bearing-boxes *e* at one side of the frame A by means of a pulley, D, (shown only in Fig. I,) and a belt. (Not shown.)

The plank is represented by E and the boards into which it is cut by F. G is a fixed guide-strip extending longitudinally of the bed *a*, against which one edge of the plank E bears as it traverses the machine, and immediately in front or at one end of this strip is situated an edging-cutter, H, on a spindle, *g*, which is driven by a pulley (not shown) in the usual manner.

I is a movable guide-strip attached to the frame A by means of links *h* and pivotal bolts *i*. This strip is moved laterally of the machine by means of a rod, *j*, having pins *k*, which rest in slots *l* in the links *h*. The means for actuating the rod *j* and for ascertaining the lateral distance which the strip I is moved will be hereinafter described. J is a second edging-cutter on a spindle, *m*, arranged to be revolved within a pocket or recess in the movable guide-strip I, in order that planks of different widths may be edged and grooved at the same time. Fig. V is a cross-section of the movable guide-strip and its cutter.

As before stated, the plank may or may not be planed at one or both surfaces, and the machine shown is devoid of such surfacing-cutters, as their illustration would only tend to complicate the drawings.

It is intended to produce with this machine tongued and grooved boards which only come in contact at one surface—such as are produced when the boards are worked singly—and to this end the upper channeling knives or cutters must cut in the plank a dovetailed channel, as shown in Fig. III.

The cutter-heads for holding the knives for channeling the upper surface of the plank are denoted by K and the said knives by *p*. These cutter-heads are secured to spindles *q*, placed at an angle with reference to the bed of the machine, (see Fig. III,) and the cutters have such angle of cutting-edge that the bottom of the dovetailed groove produced by the action of the two sets of cutters which are reversed in position is parallel with the surface of the plank.

The cutter-heads and their knives for channeling the under surface of the plank are collectively represented by *r*, and by reference to Fig. III it will be seen that they are devoid of novelty.

The dovetailed groove is designated in Fig. III by *s* and the plain one by *t*.

The plank is separated centrally of the groove or channel, so as to form two tongues by means of the cutters *u* in the heads L. These cutters (shown on an enlarged scale in Fig. VI) have hollow sides, and they are adapted by their position to cut to the vertical center of the plank or to a point half-way through

the tongue-piece. By means of these cutters the plank is not only severed into boards, but the tongues are rounded and finished at the edges. The direction taken by the plank during the operation of the machine is indicated by the arrow in Fig. I.

By referring to Fig. II it will be seen that one of the inclined cutter-heads, with its knives, performs its work before the under channeler, *r*, and consequently the plank cannot be held down directly over the latter cutter by a feed-roll or presser-bar of ordinary description. I therefore apply to the upper surface of the plank at a point directly over the lower channeling-cutter a loosely-turning presser-roller, *M*, which bears on that surface of the plank, and is furnished with a collar, *a'*, which bears on the bottom of the channel and sustains the tongue-piece while it is subjected to the action of the under channeler, (see Fig. VII, which is a section of these parts.)

N is a presser-bar of any approved design to assist in holding down the plank to the bed of the machine.

In order that both boards produced may be of a common width without reference to the width of the plank, or, in other words, that planks of different widths may be channeled and separated at the center or any other part of the plank, it is necessary that the upper and lower channelers, the separating-knives, and the pressing-roller having the collar should be susceptible of adjusting collectively laterally of the machine. To this end I therefore furnish both sides of the frame of the machine with a stationary stand, *O*, and apply to these stands a carriage, *P*, adapted to beslid in dovetailed grooves *b'*. (Shown in Fig. IV.)

The spindles of the upper and lower channeling-cutters, the presser-roller, and the separating-cutters are all journaled in this carriage and move with it. Consequently any lateral adjustment of the carriage effects a similar adjustment of all the cutters and presser-roller above named. To effect this lateral adjustment of the carriage and its attachments, I provide a screw, *Q*, the nut *R* of which is secured in the carriage *P*, and adapted at its end which is grooved to turn loosely in a step, *e'*, on the side of the frame or stand.

S is a worm-wheel on the end of the screw *Q*, and *T* is a worm in gear with the said worm-wheel and with its stem leading to the front of the machine, where it is connected to a hand-wheel shaft, *d'*, by means of sprocket-wheels *e'* and a chain indicated by a dotted line. *U* is a guide-bar projecting from the stand *O* and fitted to slide in a hole in the carriage *P*.

The means whereby the rod *j* is moved to adjust the movable guide-strip and its cutter and to hold the same after adjustment is clearly shown on an enlarged scale in Figs. VIII and IX.

V is a stand bolted to the floor.

W is a nut confined endwise in the stand *V*, but fitted to turn therein. At one end of this

nut is fastened a beveled cog-wheel, *f'*, in gear with a similar cog-wheel, *g'*, on a stem, *h'*, supported by a bracket, *i'*, extending from a stand, *V*. This stem is easily turned by a hand-wheel, *j'*, and its motion is eventually communicated to the nut *W*, which moves the rod *j* toward or from the attendant and the movable guide-strip toward or from the fixed strip. A scale, *k'*, is attached to the rod *j* at *l'* and passes through the stand *V*, by means of which the attendant may easily adjust the distance between the two guide-strips.

It is evident that in the manufacture of partition stuff inclined channelers may be substituted for the straight one at the under side of the plank, and in such case each of the knives is furnished with an extension to cut a bead. To effect this substitution, it will of course be necessary to adapt the carriage to support the lower inclined shafts carrying the cutters.

If desired, the separating-knives may be affixed to the head to which the channeling-knives are secured. The upper separator would be applied to the second upper channeler and to the second under channeler, if two are used below the plank. If a single under channeler is used, it will be attached to it.

I am aware that boards have been provided with dovetailed channels by means of cutters placed in angular positions, and that planks have been channeled and severed at the channels by means of saws which produce flat-edged tongues; but I am not aware that heretofore a plank has been provided with a dovetailed channel in its upper surface and a plain channel underneath, and then separated centrally of the said channels by means of cutters which each reach to the vertical center of the plank or to the center of the tongue-piece and round and finish the edges of the tongues, as described.

I claim as my invention—

1. In a machine for making tongue-and-groove flooring, a frame having feed-rolls adapted to carry a plank longitudinally of the said machine, and suitable cutters to cut in the surfaces of the said plank an upper and lower channel, combined with a presser-roller having a collar to project into the upper channel and bear on and thus support the tongue-piece as the under channeler is operating on the same, substantially as and for the purpose specified.

2. In a machine for making tongue-and-groove flooring, a frame carrying feed-rollers for the plank, combined with a carriage adapted to be moved laterally of the said frame and over the plank, upper and lower channeling-cutters, separating-cutters, and a presser-roller having a collar adapted to rest in the said upper channel to support the tongue-piece, all the said cutters and the presser-roller being journaled in the said laterally-

moving carriage, substantially as and for the purpose specified.

3. In a machine for making tongue-and-groove flooring, a fixed guide-strip, combined
5 with a movable guide-strip attached to some stationary part of the frame by means of slotted links, a rod having pins whereby it is attached to the said links and threaded at its
10 outer end, a stand carrying a nut adapted to turn on the said threaded rod, means to revolve the nut, and a scale adapted to move

with the said rod and pass through some stationary part of the said stand, whereby the lateral adjustment of the said movable guide-strip is effected and the width between the separated strips indicated, substantially as and
15 for the purpose specified.

GREENLEAF JOHNSON, JR.

Witnesses:

WM. T. HOWARD,
DANL. FISHER.