

(19) World Intellectual Property Organization
International Bureau



(43) International Publication Date
7 May 2009 (07.05.2009)

PCT

(10) International Publication Number
WO 2009/058621 A1

(51) International Patent Classification:
A01H 13/00 (2006.01)

(21) International Application Number:
PCT/US2008/080674

(22) International Filing Date: 22 October 2008 (22.10.2008)

(25) Filing Language: English

(26) Publication Language: English

(30) Priority Data:
11/933,743 1 November 2007 (01.11.2007) US

(71) Applicant (for all designated States except US): **INDEPENDENCE BIO-PRODUCTS HOLDINGS, LLC**
[US/US]; 5338 Sheffield Avenue, Powell, OH 43065 (US).

(72) Inventor; and

(75) Inventor/Applicant (for US only): **ERD, Ronald, A.**
[US/US]; 5338 Sheffield Avenue, Powell, OH 43065 (US).

(74) Agent: **KENNEY, Brian**; Benesch, Friedlander, Coplan & Aronoff LLP, 2300 BP Tower, 200 Public Square, Cleveland, OH 44114 (US).

(81) Designated States (unless otherwise indicated, for every kind of national protection available): AE, AG, AL, AM, AO, AT, AU, AZ, BA, BB, BG, BH, BR, BW, BY, BZ, CA, CH, CN, CO, CR, CU, CZ, DE, DK, DM, DO, DZ, EC, EE, EG, ES, FI, GB, GD, GE, GH, GM, GT, HN, HR, HU, ID, IL, IN, IS, JP, KE, KG, KM, KN, KP, KR, KZ, LA, LC, LK, LR, LS, LT, LU, LY, MA, MD, ME, MG, MK, MN, MW, MX, MY, MZ, NA, NG, NI, NO, NZ, OM, PG, PH, PL, PT, RO, RS, RU, SC, SD, SE, SG, SK, SL, SM, ST, SV, SY, TJ, TM, TN, TR, TT, TZ, UA, UG, US, UZ, VC, VN, ZA, ZM, ZW.

(84) Designated States (unless otherwise indicated, for every kind of regional protection available): ARIPO (BW, GH, GM, KE, LS, MW, MZ, NA, SD, SL, SZ, TZ, UG, ZM, ZW), Eurasian (AM, AZ, BY, KG, KZ, MD, RU, TJ, TM), European (AT, BE, BG, CH, CY, CZ, DE, DK, EE, ES, FI, FR, GB, GR, HR, HU, IE, IS, IT, LT, LU, LV, MC, MT, NL, NO, PL, PT, RO, SE, SI, SK, TR), OAPI (BF, BJ, CF, CG, CI, CM, GA, GN, GQ, GW, ML, MR, NE, SN, TD, TG).

Published:
— with international search report
— with amended claims and statement

(54) Title: ALGAE PRODUCTION

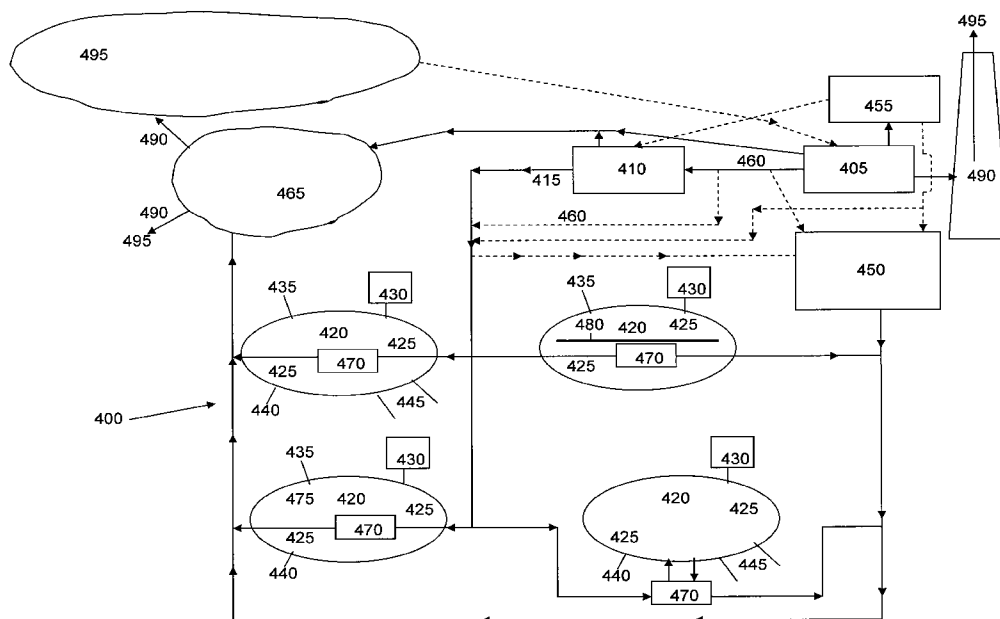

Fig. 4

(57) Abstract: Methods and systems for algae production are provided, the methods and systems generally comprising providing at least one body of water having an algae population in suspension, growing algae, heating the body of water with a heat source, heating the algae process with a heat source, drying the algae with a heat source, and covering the body of water with a cover. Heat recovery systems, algae processing, and covers are also provided.

WO 2009/058621 A1

ALGAE PRODUCTION

BACKGROUND

[0001] Commercial algae crops have been grown in temperate climates such as Hawaii, California, and Australia. These locations have been chosen due to the climate and associated algae growth benefits. In the seasonal colder regions where atmospheric and water temperatures fluctuate below ideal temperatures for algae production, algae production may not be economically maintained throughout the year. Even in the New Mexico desert, low night-time temperatures have had adverse effects on the growth of algae.

[0002] When algae are being cultivated or are reproducing, the temperature of the body of water or process has to be maintained within specific parameters day, night, and throughout the seasons of the year to achieve optimal productivity. Attempts have been made to control temperature with traditional sources of heat, including electric, natural gas, and propane. These attempts have been expensive and inefficient.

SUMMARY

[0003] In one embodiment, a method is provided for producing algae, the method comprising: providing at least one body of water having an algae population in suspension, wherein the body of water has an environment that is monitored for at least one of: nitrogen, nitrates, nitrogen containing substances, phosphorous, phosphates, phosphorous containing substances, potassium, potassium containing substances, silicon, silica, silicates, silicon containing substances, partial pressure of carbon dioxide, pH, temperature, and population density of the algae population in suspension; heating the body of water with a heat source; wherein the heat source comprises at least one of: a supply heat source, a recovered heat source, and a waste heat source from at least one of: a power plant, an industrial process, a cement plant, a kiln, an agricultural product processing plant, a processing plant, an incinerator, a furnace, an oven, an oil refinery, a petrochemical plant, a chemical plant, an ethanol plant, an amine treating plant, a natural gas processing plant, a steel plant, a metals plant, an ammonia plant, a coal gasification

plant, a refinery, a liquid synthetic fuel plant, a gas synthetic fuel plant, an industrial plant, and a manufacturing plant; and growing the algae population.

[0004] In another embodiment, a method is provided for producing algae, the method comprising: processing algae with a heat source; wherein the heat source comprises at least one of: a supply heat source, a recovered heat source, and a waste heat source from at least one of: a power plant, an industrial process, a cement plant, a kiln, an agricultural product processing plant, a processing plant, an incinerator, a furnace, an oven, an oil refinery, a petrochemical plant, a chemical plant, an ethanol plant, an amine treating plant, a natural gas processing plant, a steel plant, a metals plant, an ammonia plant, a coal gasification plant, a refinery, a liquid synthetic fuel plant, a gas synthetic fuel plant, an industrial plant, and a manufacturing plant.

[0005] In yet another embodiment, a system is provided for heat recovery, the system comprising: at least one heat source; wherein the heat source comprises at least one of: a supply heat source, a recovered heat source, and a waste heat source from at least one of: a power plant, an industrial process, a cement plant, a kiln, an agricultural product processing plant, a processing plant, an incinerator, a furnace, an oven, an oil refinery, a petrochemical plant, a chemical plant, an ethanol plant, an amine treating plant, a natural gas processing plant, a steel plant, a metals plant, an ammonia plant, a coal gasification plant, a refinery, a liquid synthetic fuel plant, a gas synthetic fuel plant, an industrial plant, and a manufacturing plant; at least one heat consuming process; wherein the at least one heat consuming process is at least one of: a body of water with an algae in suspension, an algae drying process, an algae processing, an algae growing, an algae production, a photobioreactor; at least one heat transmitting device; and a plurality of fluid movers.

[0006] In another embodiment, a method is provided for producing algae, the method comprising: providing at least one body of water having an algae population in suspension, wherein the body of water has an environment that is monitored for at least one of: nitrogen, nitrates, nitrogen containing substances, phosphorous, phosphates, phosphorous containing substances, potassium, potassium containing substances, silicon, silica, silicates, silicon containing substances, partial pressure of carbon dioxide, pH, temperature, and population density of the algae in suspension; covering the body of

water with a cover at least partially supported by a structure; and growing the algae population.

BRIEF DESCRIPTION OF THE DRAWINGS

[0007] In the accompanying drawings which are incorporated in and constitute a part of the specification, embodiments are illustrated which, together with the detailed description given below, serve to describe exemplary embodiments. It will be appreciated that the illustrated boundaries of elements (e.g. boxes, groups of boxes, or other shapes) in the figures represent but exemplary boundaries. One of ordinary skill in the art will appreciate, for example, that one element may be designed as multiple elements or that multiple elements may be designed as one element. In addition, one of ordinary skill in the art will appreciate that one component may be designed as multiple components or that multiple components may be designed as one component. One skilled in the art will also appreciate that one process or method may be designed with one order of components or that it may be designed with another order of components. An element shown as an internal component of another element may be implemented as an external component and vice versa. The drawings and components therein are not to any scale. Certain components may be omitted and others shown enlarged to facilitate understanding.

[0008] **Figure 1** is a schematic of an industrial process.

[0009] **Figure 2** is a schematic of an industrial process.

[0010] **Figure 3** illustrates an industrial process.

[0011] **Figure 4** illustrates an industrial process and algae production.

[0012] **Figure 5** illustrates an industrial process and algae production.

[0013] **Figure 6** illustrates a section of the industrial process and and algae production from **Figure 5**.

[0014] **Figure 7** illustrates an industrial process and algae production.

[0015] **Figure 8** illustrates an industrial process and algae production.

[0016] **Figure 9** illustrates an industrial process and algae production.

- [0017] **Figure 10** illustrates an industrial process and algae production.
- [0018] **Figure 11** illustrates a heat exchanger.
- [0019] **Figure 12** illustrates a heat exchanger.
- [0020] **Figure 13** illustrates a heat exchanger.
- [0021] **Figure 14** illustrates a heat exchanger.
- [0022] **Figure 15** illustrates covers.
- [0023] **Figure 16** illustrates a body of water with algae in suspension with a cover.

DETAILED DESCRIPTION

[0024] The following includes definitions of selected terms employed herein. The definitions include various examples and/or forms of components that fall within the scope of a term and that may be used for implementation. The examples are not intended to be limiting. Both singular and plural forms of terms may be within the definitions.

[0025] “Algae processing” and “processing algae,” as used herein, refers to the steps including harvesting the algae in suspension to the time of shipping the algae or algae derived products, and the like, which may include drying the algae.

[0026] “Algae production” and “producing algae,” as used herein, refers to steps including growing algae and algae processing.

[0027] “Growing algae,” “growing the algae,” and “algae growth,” as used herein, refers to the steps including algae in culture to when algae is in suspension just prior to the beginning of a harvesting step.

[0028] “Heat consuming process” and “heat consuming method,” as used herein, refers to processes, methods, or entities that consume heat from a waste heat source, recovered heat source, or supply heat source, including at least one of: a body of water with algae in suspension, algae drying process, algae processing, processing algae, growing algae, algae production, a body of water with algae in suspension covered with a greenhouse, a body of water with algae in suspension covered with a cover, a body of water with algae in suspension without a cover, a photobioreactor covered with a cover, a photobioreactor without a cover, and the like.

[0029] “Heat source,” as used herein, refers to at least one of: supply heat source, recovered heat source, waste heat source, and the like, from at least one of: a power plant, an industrial process, a cement plant, a kiln, an agricultural product processing plant, a processing plant, an incinerator, a furnace, an oven, an oil refinery, a petrochemical plant, a chemical plant, an ethanol plant, an amine treating plant, a natural gas processing plant, a steel plant, a metals plant, an ammonia plant, a coal gasification plant, a refinery, a liquid synthetic fuel plant, a gas synthetic fuel plant, an industrial plant, a manufacturing plant, and the like.

[0030] “Heat transfer device” as used herein, refers to one of the following: heat exchanger, a shell and tube heat exchanger, a plate heat exchanger, a regenerative heat exchanger, a fluid heat exchanger, a phase change heat exchanger, a parallel flow heat exchanger, a cross flow heat exchanger, a counter flow heat exchanger, a nozzle, an injector, a pump, a fan, a pipe, a condenser, a duct, cooling tower, air cooler, and the like.

[0031] “Recovered heat source,” as used herein, refers to a source of heat that has been recovered from at least one of: a waste heat source and a supply heat source. The recovery can be accomplished either through a heat exchanger or directly.

[0032] “Supply heat source,” as used herein, refers to a source of heat that is in its primary use or primary and secondary use, including steam directly from a boiler that is or can be made available to a point of use, hot air directly from a natural gas heater that is or can be made available to a point of use, and the like. The supply heat source can be in the form of at least one of: liquid, gas, vapor, steam, and the like and at least one of: elevated temperatures and elevated pressures.

[0033] “Waste heat output,” as used herein, refers to discharge of heat from a waste heat source and the like.

[0034] “Waste heat source,” as used herein, refers to industrial heat that is not used by an industrial process and the like, excluding exhaust stack gas.

[0035] One or more of the embodiments disclosed herein find application in heating algae production processes and methods that include algae in suspension in a body of water, in a photobioreactor, in a greenhouse, in algae processing, in processing algae, in

growing algae, in algae production, and the like. Uses of the algae can be for the production of algae oil, beta carotene, nutritional supplements, nutritional ingredients in food, and an ingredient in animal food, solid fuel, liquid fuel, gaseous fuel, algae suspensions, and the like. Algae could be further processed to produce nutrients, fuel, biodiesel, algae-derived equivalent of petrochemicals, and the like.

[0036] Generally, several embodiments of a method or process are provided to use heat in heat consuming processes or methods. In such a method or process, heat from an industrial process may be used to maintain or increase the temperature of the body of water or process. The heat source from the industrial process can be a heat that would have been dispersed as waste into the environment, any other type of heat source, or any combination of heat sources. The heat consuming process may be using heat that would have been dispersed as waste into the environment and, thus as a recovered heat source, the cost of the energy source is less and the process or method is efficient and makes the production or method economically competitive in regions with less than ideal temperatures for optimal algae growth. In an alternative method or process, as a backup heat source, supplemental heat source, or alternative heat source, the heat consuming process or method uses a supply heat source instead of a waste heat.

[0037] **Figure 1** is a schematic of one embodiment illustrating a general industrial process **100** that has an input energy source **110**, a production process **120**, a product output **130**, a supply heat source **140**, a waste heat source **160**, and a waste heat output **190** that is dispersed into the environment **195** surrounding the industrial process **100**. The supply heat source **140** is a supply to a process or a method outside of production process **120**. In another alternative embodiment (not shown), the supply heat source **140** is a supply to a process or a method inside of production process **120**. The general industrial process **100** can be one of many industrial processes that discharge a waste heat output **190** into the environment **195**, including: a power plant, a cement plant, a kiln, an agricultural product processing plant, a processing plant, an incinerator, a furnace, an oven, an oil refinery, a petrochemical plant, a chemical plant, an ethanol plant, an amine treating plant, a natural gas processing plant, a steel plant, a metals plant, an ammonia plant, a coal gasification plant, a refinery, a liquid synthetic fuel plant, a gas synthetic

fuel plant, an industrial plant, a manufacturing plant, and the like. The supply heat source **140**, waste heat source **160**, and waste heat output **190** can be in various forms including: liquid, gas, vapor, and the like. In an alternative embodiment (not shown), there are multiple industrial processes **100**. In another alternative embodiment (not shown), there are multiple supply heat sources **140**. In yet another embodiment (not shown), there are multiple waste heat sources **160**. In another alternative embodiment (not shown), there are multiple waste heat outputs **190**. In another alternative embodiment (not shown), there is a combination of at least two heat sources, which may include: a supply heat source **140**, a waste heat source **160**, and a waste heat output **190**. In yet another alternative embodiment (not shown), the heat source may not include exhaust stack gas.

[0038] **Figure 2** is a schematic of one embodiment illustrating an industrial process **200** that has an input energy source **210**, a production process **220**, a product output **230**, a supply heat source **240**, a heat transfer device **250**, a waste heat source **260**, a waste heat output **290** that is dispersed into the environment **295** surrounding the industrial process **200**, and a recovered heat source **215**. The supply heat source **240** is a supply to a process or a method outside of production process **220**. In an alternative embodiment (not shown), the supply heat source **240** is a supply to a process or a method inside of production process **220**. The industrial process **200** is similar to the industrial process **100** in **Figure 1** above, but in addition, it has two heat transfer devices **250** and two recovered heat sources **215**. In the illustrated embodiment, the two heat transfer devices **250** absorb heat from the waste heat source **260** and/or supply heat source **240** before the waste heat source **260** is dispersed into the environment and/or the supply heat source **240** is transferred to another point of use, producing a recovered heat source **215** and waste heat output **290**. In an alternative embodiment (not shown), there is one heat transfer device **250** and one recovered heat source **215**. In another alternative embodiment (not shown), there are more than two heat transfer devices **250** and more than two recovered heat sources **215**. In yet another alternative embodiment (not shown), heat is recovered from a supply heat source **240** simultaneously while being transferred to another point of use. In another alternative embodiment (not shown), a supply heat source **240** may not be used by industrial process **200** but comes from another source. In another alternative embodiment (not shown), the recovered heat source **215** may be

replaced with at least one of: a supply heat source **240**, a waste heat source **260**, and a recovered heat source **215**. In yet another alternative embodiment (not shown), the heat source may not include exhaust stack gas.

[0039] **Figure 3** is a schematic of one embodiment of an industrial process **300** that includes an input energy source **310**, a production process that includes steps **320a-320d**, a product output **330**, a supply heat source **340**, a heat transfer devices **350**, a waste heat source **360**, and waste heat outputs **390a-390c** that are dispersed into the environment **395** surrounding the industrial process **300**. In the illustrated embodiment, the industrial process **300** has one input energy source **310** that can include at least one of the following: coal, natural gas, propane, oil, butane, diesel, hazardous waste, biomass, refuse, paper, regenerative fuels, and the like. In an alternative embodiment (not shown), the industrial process **300** may have more than one input energy sources **310**.

[0040] In the illustrated embodiment, the industrial process **300** has four production process steps **320a-320d**. In an alternative embodiment (not shown), the industrial process **300** may have less than four production process steps. In yet another alternative embodiment (not shown), the industrial process **300** may have more than four production process steps. Further, in the illustrated embodiment, the industrial process **300** has one product output **330**. In an alternative embodiment (not shown), the industrial process **300** may have more than one product output **330**. Additionally, in the illustrated embodiment, the industrial process **300** has one supply heat source **340**, sometimes known as the heat inflow into the process. In an alternative embodiment (not shown), the industrial process **300** may have more than one supply heat sources **340**. In another alternative embodiment (not shown), the supply heat source **340** may encompass production process step **320d**.

[0041] With continued reference to **Figure 3**, the industrial process **300** has one heat transfer device **350**. In an alternative embodiment (not shown), the industrial process **300** may have more than one heat transfer devices **350**. In the illustrated embodiment, the industrial process **300** has three waste heat outputs **390a-390c** that can include three of the following: water that may be at a higher temperature relative to the water (e.g. ocean, lake, river, pond, and the like) that it is dispersed into, hot water or steam which dissipates heat in a cooling tower, hot water or steam which dissipates heat in an air

cooler that discharges warm air, and hot water vapor or steam dispersed from an industrial process. In an alternative embodiment (not shown), the industrial process 300 may have less than three waste heat outputs 390. In yet another alternative embodiments (not shown), the industrial process 300 may have more than three waste heat outputs 390.

[0042] **Figure 4** is a schematic of one embodiment of algae production 400 that includes an industrial process 405, a heat transfer device 410, a recovered heat source 415, a body of water 420, an algae population 425, a body of water control/monitor 430, a cover 435, a liner 440, algae processing 450, a supply heat source 455, a waste heat source 460, an industrial process contained body of water 465, an environment 495 surrounding algae production 400, a heat transfer device 470 inside the body of water 420 or in the proximity of the body of water 420, a mixer 475, a center divider 480, and a waste heat output 490 that is dispersed to the environment 495. In yet another alternative embodiment, algae production 400 may include a harvesting system 445. The industrial process 405 can be one of many industrial processes that discharge a waste heat source 460 or supply heat source 455, including: a power plant, a cement plant, a kiln, an agricultural product processing plant, a processing plant, an incinerator, a furnace, an oven, an oil refinery, a petrochemical plant, a chemical plant, an ethanol plant, an amine treating plant, a natural gas processing plant, a steel plant, a metals plant, an ammonia plant, a coal gasification plant, a refinery, a liquid synthetic fuel plant, a gas synthetic fuel plant, an industrial plant, a manufacturing plant, and the like. In an alternative embodiment (not shown), there are multiple industrial processes 405. In an alternative embodiment (not shown), there is not an industrial process contained body of water 465. In an alternative embodiment (not shown), there are more than one industrial process contained bodies of water 465. In yet another alternative embodiment (not shown), heat transfer device 410 is not used in algae production 400.

[0043] With continued reference to **Figure 4**, the supply heat source 455 and waste heat source 460 can be in various forms including: liquid, gas, vapor, steam, and the like. The dashed lines from supply heat source 455, from waste heat source 460, and to algae processing 450 represent alternative embodiments and configurations. In another alternative embodiment (supply heat source 455 shown as a dashed line), waste heat

source **460** is the only heat source to heat transfer device **410**. In another alternative embodiment (not shown), there are more than one supply heat sources **455**. In yet another alternative embodiment (not shown), there are more than one waste heat sources **460**. In another alternative embodiment (not shown), there are a combination of supply heat sources **455** and waste heat sources **460**. In an alternative embodiment (not shown), the only input to heat transfer device **410** is a supply heat source **455**. In another alternative embodiment (not shown), another form of heat is supplied to heat transfer device **410** including at least one of: supply heat source **455**, waste heat source **460**, and the like. In yet another embodiment (not shown), the heat source may not include exhaust stack gas.

[0044] In the illustrated embodiment, there is one heat transfer device **410**. In an alternative embodiment (not shown), there is more than one heat transfer device **410**. In the illustrated embodiment, one recovered heat supply **415** goes to the body of water **420**. The recovered heat supply **415** may be transferred to the body of water **420** by a plurality of fluid movers, including a plurality of the following: a pump, a fan, a mixer, a pipe, a duct, an injector, a nozzle, a damper, and a valve. In an alternative embodiment (not shown), the plurality of fluid movers include at least one of: a supply heat system, a return heat system, a return of the heat-transfer medium following the heat transfer system, and a fluid mover by-pass. In an alternative embodiment (not shown), there is more than one recovered heat supply **415** that goes to the body of water **420**. In another alternative embodiment (not shown), a waste heat source **460** may go directly to the body of water **420**. In another alternative embodiment (not shown), a supply heat source **455** may go directly to the body of water **420**. In yet another alternative embodiment (not shown), algae production **400** includes a cover **435** but lacks an outside heat source, including one of: a recovered heat supply **415**, a supply heat source **455**, and a waste heat source **460**. In another alternative embodiment (not shown), algae production **400** does not include a cover **435** but includes an outside heat source, including one of: a recovered heat supply **415**, a supply heat source **455**, and a waste heat source **460**.

[0045] With continued reference to **Figure 4**, in the illustrated embodiment, four bodies of water **420** consume heat. In an alternative embodiment (not shown), there are

less than four bodies of water **420**. In another alternative embodiment (not shown), there are more than four bodies of water **420**. In yet another alternative embodiment (not shown), algae production **400** includes at least one of: a body of water having an algae population in suspension, a photobioreactor, algae processing, growing algae, and an algae drying process. In another embodiment (not shown), algae production **400** may not include a photobioreactor. In the illustrated embodiment, the bodies of water **420** are all oval. In an alternative embodiment (not shown), the bodies of water **420** are in the shape of at least one of: a circle, an oval, an oval with a center island, an oval with a center divider, a raceway, a square, a rectangle, a trench, a trench that narrows toward the bottom, a rounded rectangle, a trapezoid, a triangle, a cross, a crescent moon shape, piping, and the like. In yet another alternative embodiment (not shown), the body of water **420** may not include a photobioreactor.

[0046] In the illustrated embodiment, an algae population **425** is within the body of water **420**. In an alternative embodiment (not shown), the algae population **425** is within at least one of: a body of water having an algae population in suspension, a photobioreactor, algae processing, growing algae, and an algae drying process. In another alternative embodiment (not shown), the algae population is from at least one of: a local algae population, a foreign algae population, and a genetically modified algae. In yet another alternative embodiment (not shown), the algae population **425** may not be within a photobioreactor. Local algae populations are algae found in nature in less than or equal to one-hundred and fifty (150) miles from the algae production site. Foreign algae populations are algae found in nature outside one-hundred and fifty (150) miles from the algae production site or genetically modified algae.

[0047] In the illustrated embodiment, the body of water **420** that contains an algae population **425** is maintained by use of a body of water control/monitor **430**. In the illustrated embodiment, the body of water **420** is being monitored and controlled for temperature by the body of water control/monitor **430**. In an alternative embodiment (not shown), the body of water **420** is being monitored and controlled by the body of water control/monitor **430** for at least one of: nitrogen, nitrates, nitrogen containing substances, phosphorous, phosphates, phosphorous containing substances, potassium, potassium

containing substances, silicon, silica, silicates, silicon containing substances, partial pressure of carbon dioxide, pH, temperature, and population density of the algae in suspension.

[0048] In the illustrated embodiment, the body of water **420** is heated with the recovered heat supply **415** by transmitting heat from hot gas to a heat transfer device **470** inside the body of water **420**. In an alternative embodiment (not shown), the body of water **420** is heated with the recovered heat supply **415** by at least one of the following: hot gas to a heat exchanger located in the body of water that transmits heat into the body of water, hot gas to a heat exchanger located in proximity to the body of water that transfers heat to and into the body of water, hot gas injection into the body of water, hot vapor injection into the body of water, hot vapor to a heat exchanger in the body of water that transfers heat into the body of water, hot vapor to a heat exchanger located in proximity to the body of water that transfers heat to and into the body of water, hot liquid injection directly into the body of water, hot liquid transmitted to a heat exchanger located in the body of water that transfers heat into the body of water, hot liquid transmitted to a heat exchanger located in proximity to the body of water that transfers heat to and into the body of water, body of water fluid transmitted to a heat exchanger located in the industrial process that transfers heat to the body of water fluid which is then returned to the body of water, body of water fluid transmitted to a heat exchanger located in proximity to the industrial process that transfers heat to the body of water fluid which is then returned to the body of water, hot vapor transmitted to the body of water in a pipe or a duct that transfers heat into the body of water through the pipe or the duct, hot gas transmitted to the body of water in a pipe or a duct that transfers heat into the body of water through the pipe or the duct, and hot liquid transmitted to the body of water in a pipe or a duct that transfers heat into the body of water through the pipe or the duct. In the alternative embodiment where the heat transfer device **470** is located in proximity to the heat consuming process, further fluid transfer devices would be needed to transfer the heat from the heat exchanger to the body of water **420** or heat consuming process. In yet another embodiment (not shown), the body of water **420** is heated with the supply heat source **455** by at least one of the following: hot gas to a heat exchanger located in the body of water that transmits heat into the body of water, hot gas to a heat exchanger

located in proximity to the body of water that transfers heat to and into the body of water, hot gas injection into the body of water, hot vapor injection into the body of water, hot vapor to a heat exchanger in the body of water that transfers heat into the body of water, hot vapor to a heat exchanger located in proximity to the body of water that transfers heat to and into the body of water, hot liquid injection directly into the body of water, hot liquid transmitted to a heat exchanger located in the body of water that transfers heat into the body of water, hot liquid transmitted to a heat exchanger located in proximity to the body of water that transfers heat to and into the body of water, body of water fluid transmitted to a heat exchanger located in the industrial process that transfers heat to the body of water fluid which is then returned to the body of water, body of water fluid transmitted to a heat exchanger located in proximity to the industrial process that transfers heat to the body of water fluid which is then returned to the body of water, hot vapor transmitted to the body of water in a pipe or a duct that transfers heat into the body of water through the pipe or the duct, hot gas transmitted to the body of water in a pipe or a duct that transfers heat into the body of water through the pipe or the duct, and hot liquid transmitted to the body of water in a pipe or a duct that transfers heat into the body of water through the pipe or the duct. In still another alternative embodiment (not shown), waste heat source 460 transmits heat to the body of water through a pipe, duct, or the like that runs through the body of water.

[0049] In the illustrated embodiment, the body of water 420 may be covered with a cover 435. The cover 435 is made of material that allows passage of light, the material that allows passage of light being one of: plastic, polymeric material, glass, acrylic, polycarbonate, and the like. In another embodiment (not shown), the cover 435 may be made of one of: polypropylene and polyethylene. In yet another embodiment (not shown), the cover 435 includes at least one of: insulation, single layer of covering, multiple layers of covering, multiple layers separated by an air or gas pocket of circulated or stagnant air or gas, an opening to allow heat removal, a vent for gaseous material removal, sections that can be removed from above the body of water, a retractable section, a removable panel, a roll-up section, and the like. In another embodiment (not shown), the cover 435 is of a construction including at least one of: gutter connected, free standing, round house, round house with sides, gothic arch, gothic arch with sides, cover

with strapping, cover without strapping, floating cover, cover supported over a structure, and a cover supported over a divider. In another embodiment (not shown), the cover **435** is supported by one of: a structure, divider, and the like. In yet another embodiment (not shown), the support for the cover **435** is partially from one of: a structure and divider. In another embodiment (not shown), the structure that supports the cover **435** is made of earth, steel, plastic, glass, polymeric material, fiberglass, dirt, soil, rock, and the like. In yet another embodiment (not shown), the divider that supports the cover **435** is made of earth, steel, plastic, glass, polymeric material, fiberglass, dirt, soil, rock, and the like. In another embodiment (not shown), the cover **435** is over a photobioreactor with one of: supports and without supports. In yet another embodiment (not shown), the cover **435** is placed over a photobioreactor and the photobioreactor forms part of the structure that supports the cover **435**. In another embodiment (not shown), algae production **400** does not have a cover **435**.

[0050] With continued reference to **Figure 4**, in the illustrated embodiment, the body of water **420** may have a liner **440** made from a geo-membrane material that lines the lower surface of the body of water **420**. In an alternative embodiment (not shown), the liner **440** may be made from at least one of: a geo-membrane, plastic, polymeric material, rubber, synthetic rubber, fiberglass, cement, crushed stone, sand, clay, soil, and dirt. In yet another alternative embodiment (not shown), the body of water **420** may not have a liner **440**.

[0051] In the illustrated embodiment, the algae population **425** in the body of water **420** may be harvested with a harvesting system **445** with nano-particle filters. In an alternative embodiment (not shown), the algae population **425** in the body of water **420** may be harvested with a harvesting system **445** that includes at least one of: a nano-particle filter, a skimmer, a centrifuge, a vacuum, dissolved air flotation, a mechanical press, and a pump.

[0052] In the illustrated embodiment, after the algae population **425** is grown and then may be harvested with the harvesting system **445**, the algae may be transferred to algae processing **450**, may be dried with the recovered heat source **415**, and then may be further processed. In another alternative embodiment (not shown), the algae is dried in

algae processing **450** with at least one of: a recovered heat source **415**, a supply heat source **455**, and a waste heat source **460**. In yet another alternative embodiment (not shown), the algae is dried in algae processing **450** with a backup heat source including at least one of: a recovered heat source **415**, a supply heat source **455**, a waste heat source **460** and the like from the industrial process **405** or steam heat from an algae production process **400**. In the illustrated embodiment, the recovered heat supply **415** is returned to the environment **495** after algae production **400** consumes the heat. In another alternative embodiment (not shown), some or all of the recovered heat supply **415** is returned back to the at least one of: industrial process **405**, heat transfer device **410**, and environment **495**. In yet another alternative embodiment (not shown), the environment **495** may include at least one of: air, water, earth, and underground. The algae production of **Figure 4** may contain any or all of the disclosed embodiments and disclosed alternative embodiments of **Figures 1-3** discussed above and **Figures 5-10** discussed below.

[0053] **Figure 5** is a schematic of one embodiment of algae production **500** that includes an industrial process **505**, a heat transfer device **510**, a recovered heat source **515**, a body of water **520**, an algae population **525**, body of water controls/monitors **530**, a cover **535**, a liner **540**, a harvesting system **545**, algae processing **550**, a supply heat source **555** (not shown), a waste heat source **560**, an industrial process contained body of water **565**, an environment **595** surrounding algae production **500**, a heat exchanger **570**, a mixer **575**, center divider **580**, a waste heat output **590** that is dispersed to the environment **595**, and a CO₂ rich exhaust gas source combined with hot gas **585**. In the illustrated embodiment, the industrial process **505** is a kiln cement process with industrial process steps **505a-505k**. In the illustrated embodiment, the heat exchange bypass process **505j** adds flexibility to the system to allow the operator of the industrial process **505** to turn the heat transfer device **510** on or off. If the heat transfer device **510** is on, then waste heat source **560** goes through heat transfer device **510**. If the heat transfer device **510** is off, then waste heat source **560** goes through the bypass **505k**. In the illustrated embodiment, the industrial process **505** has three heat transfer devices **510**, labeled 1, 2, and 3. In another embodiment (not shown), there are less than three heat transfer devices **510**. In yet another embodiment (not shown), there are more than three heat transfer devices **510**. In yet another alternative embodiment, algae production **500**

may not include a harvesting system **545**. The illustrated embodiment includes a mixer **575** and a center divider **580** in one body of water **520**. In another embodiment, a mixer **575** or a center divider **580** are in at least one body of water **520**. In another embodiment, the mixer **575** and a center divider **580** are not in a body of water **520**. In another embodiment, the mixer **575** or a center divider **580** are not in a body of water **520**. In the illustrated embodiment, a CO₂ rich exhaust gas source combined with hot gas **585** is piped into the algae production **500** before being dispersed into the environment **595**. In an alternative embodiment (not shown), the CO₂ rich exhaust gas source combined with hot gas **585** is not part of algae production **500**.

[0054] With continued reference to **Figure 5**, the cover **535** may include at least one of: insulation, single layer of covering, multiple layers of covering, multiple layers separated by a gas or air pocket of circulated or stagnant gas or air, an opening to allow heat removal, a vent for gaseous material removal, sections that can be removed from above the body of water, a retractable section, a removable panel, a roll-up section, and the like. In another embodiment (not shown), the cover **535** is of a construction at least one of: gutter connected, free standing, round house, round house with sides, gothic arch, gothic arch with sides, cover with strapping, cover without strapping, floating cover, cover draped over a divider, and the like. In another embodiment (not shown), a divider is the only structure that supports the cover **535**. In yet another embodiment (not shown), the cover may be supported by a structure. In another embodiment (not shown), a center divider is part of the structure that supports the cover **535**. In another embodiment (not shown), the cover **535** is not part of algae production **500**.

[0055] In the illustrated embodiment, the body of water **520** may have a liner **540** made from a geo-membrane material that lines the lower surface of the body of water **520**. In an alternative embodiment (not shown), the liner **540** is made from at least one of: a geo-membrane, plastic, polymeric material, rubber, synthetic rubber, fiberglass, cement, crushed stone, sand, clay, and dirt. In yet another alternative embodiment (not shown), the body of water **520** does not have a liner **540**. The algae production of **Figure 5** may contain any or all of the disclosed embodiments and disclosed alternative embodiments of **Figures 1-4** discussed above and **Figures 6-10** discussed below.

[0056] **Figure 6** is an enlarged schematic sectional view of the heat transfer device **510** including a secondary fan **505j** and a by-pass **505k**, of one embodiment of algae production in conjunction with an industrial process **505** in **Figure 5**, discussed above. The sectional view shows a primary exhaust fan **505h**, a secondary by-pass fan **505j**, a heat transfer device **510**, a waste heat source **560**, a waste heat output **590**, a CO₂ supply with hot gas **585**, and a return waste heat source **560**. The illustrated embodiment shows how waste heat source **560** can either be directed through primary fan **505h** to the waste heat output **590** or be directed to secondary by-pass fan **505j** where the waste heat source **560** can be directed to the heat transfer device **510** or to the by-pass **505k** where the waste heat source **560** is sent to the industrial waste heat output **590** and dispersed to environment **595**, rather than the algae process. In an alternative embodiment (not shown), waste heat source **560** can flow to both **505h** and **505j** in what is sometimes known as a split stream or slip stream. In the illustrated embodiment, there is one heat transfer device **510** and one by-pass **505k**. In alternative embodiments (not shown), there are more than one heat transfer devices **510** and more than one by-passes **505k**. In another embodiment (not shown), the waste heat source **560** is dispersed back to algae production **500**. In an alternative embodiment (not shown), there is no secondary by-pass fan **505j**. In yet another alternative embodiment (not shown), the waste heat source **560** and CO₂ rich exhaust gas source combined with hot gas **585** are combined in one output. In still another embodiment (not shown), the CO₂ rich exhaust gas source combined with hot gas **585** comes from a location after primary fan **505h**. In yet another embodiment (not shown), the CO₂ rich exhaust gas source combined with hot gas **585** comes from an area further upstream of primary fan **505h**. In yet another embodiment (not shown), the piping configuration varies but still achieves the purpose embodied in **Figure 6**.

[0057] **Figure 7** is a schematic of one embodiment of algae production **700** that includes an industrial process **705**. The algae production **700** is similar to the algae production **400**, discussed above in **Figure 4**, including having a heat transfer device **710**, a recovered heat source **715**, a body of water **720**, an algae population **725**, a body of water control/monitor **730**, a cover **735**, a liner **740**, a harvesting system **745**, algae processing **750**, a supply heat source **755**, a waste heat source **760**, a waste heat output **790**, an environment **795** surrounding algae production **700**, and a heat transfer device

770 inside the body of water 720 or in proximity to the body of water 720. In the illustrated embodiment, the industrial process 705 is a power plant that supplies heat in the form of hot water or steam as supply heat source 755 or waste heat source 760. In another embodiment (not shown), the industrial process 705 can be at least one of: a power plant, an industrial process, a cement plant, a kiln, an agricultural product processing plant, a processing plant, an incinerator, a furnace, an oven, an oil refinery, a petrochemical plant, a chemical plant, an ethanol plant, an amine treating plant, a natural gas processing plant, a steel plant, a metals plant, an ammonia plant, a coal gasification plant, a refinery, a liquid synthetic fuel plant, a gas synthetic fuel plant, an industrial plant, a manufacturing plant, and the like. In the illustrated embodiment, after the body of water 720 absorbs the heat from the recovered heat source 715 transferring medium via the heat transfer device 770, then the cooled recovered heat source 715 is returned to the industrial process 705 or is dispersed into the environment 795. The algae production of **Figure 7** may contain any or all of the disclosed embodiments and disclosed alternative embodiments of **Figures 1-6** discussed above and **Figures 8-10** discussed below.

[0058] **Figure 8** is a schematic of one embodiment of algae production 800 that includes an industrial process 805. The algae production 800 is similar to algae production 400, discussed above in **Figure 4**, including having a heat transfer device 810, a recovered heat supply 815, a body of water 820, an algae population 825, a body of water control/monitor 830, a cover 835, a liner 840, a harvesting system 845, algae processing 850, a supply heat source 855 (not shown), a waste heat source 860, a waste heat output 890 that removes waste heat from the industrial process to an environment 895 that surrounds the algae production 800, and a heat transfer device 870 inside the body of water 820. In the illustrated embodiment, the waste heat output 890 is an air cooler that removes waste heat from waste heat source 860, if not recovered by the heat transfer device 810 in the form of a recovered heat supply 815. In the illustrated embodiment, the waste heat source 860 is transferred to the heat transfer device 810 and then can either go to one of several bodies of water 820 where the water absorbs the recovered heat through heat transfer device 870 or it can be dispersed to the environment 895 through waste heat output 890. In the illustrated embodiment, on the return loop, depending on operating conditions of the industrial process 805, recovered heat supply

815 can take four paths, labeled 1, 2, 3, and 4, including one of: dispersed to the environment **895** through the waste heat output **890**, returned directly to the environment **895**, returned back to the industrial process **805**, and returned back to the heat transfer device **810** where it will absorb more waste heat energy. In another embodiment (not shown), the algae production **800** is supplied with heat from a supply heat source **855**. In another illustrated embodiment, the waste heat output **890** is one of: an air cooler, a water tower, an exhaust stack, a cooling tower, a heat sink, and the like. The algae production of **Figure 8** may contain any or all of the disclosed embodiments and disclosed alternative embodiments of **Figures 1-7** discussed above and **Figures 9-10** discussed below.

[0059] **Figure 9** is a schematic of one embodiment of algae production **900** that includes an industrial process **905**. The algae production **900** is similar to the algae production **800**, discussed above in **Figure 8**, including having a body of water **920**, an algae population **925**, a body of water control/monitor **930**, a cover **935**, a liner **940**, a harvesting system **945**, algae processing **950** (not shown), a supply heat source **955** (not shown), a waste heat source **960**, a waste heat output **990**, an environment **995** surrounding the algae production **900**.

[0060] In the illustrated embodiment, the waste heat source **960** is warm air, vapor, gas, water, or steam that is transferred to the location of the body of water **920** and algae population **925**, then directly injected into the body of water **920**. In an alternative embodiment (as shown with dotted lines), the waste heat source **960** is combined with a CO_2 exhaust supply combined with hot gas or vapor **985** and then injected into the body of water **920**. In yet another embodiment, hot air from a waste heat output **960** is mixed with an industrial exhaust stream containing CO_2 exhaust supply combined with hot gas or vapor **985** and then injected into the body of water **920**. In the illustrated embodiment, since the waste heat source **960** is injected into the body of water **920**, there is no return loop back to the industrial process **905**. In yet another alternative embodiment (not shown), since the waste heat source **960** is injected into the one body of water **920**, there is a return loop from **920** into an industrial process contained body of water **965**. In another embodiment (not shown), the algae production **900** is supplied with heat from a

supply heat source **955**. In another embodiment (not shown), the waste heat output **990** is at least one of: an air cooler, a water tower, an exhaust stack, a cooling tower, a heat sink, and the like. The algae production of **Figure 9** may contain any or all of the disclosed embodiments and disclosed alternative embodiments of **Figures 1-8** discussed above and **Figure 10** discussed below.

[0061] **Figure 10** is a schematic of one embodiment of algae production **1000** that includes an industrial process **1005**. The algae production **1000** is similar to the algae production **400**, discussed above in **Figure 4**, including having a body of water **1020**, an algae population **1025**, a body of water control/monitor **1030**, a cover **1035**, a liner **1040**, a harvesting system **1045**, algae processing **1050** (not shown), a supply heat source **1055** (not shown), a waste heat source **1060**, a waste heat output **1090** (not shown), an environment **1095** surrounding the algae production **1000**. In the illustrated embodiment, the waste heat source **1060** is warm water that is injected directly into the body of water **1020** and algae population **1025**. Further, illustrating the same embodiment, water from the body of water **1020** is then circulated back to the industrial process **1005** where more heat is absorbed from the industrial process **1005** and returned to the body of water **1020** as a waste heat source **1060**. In another embodiment (not shown), the liquid from the body of water **1020** is used in combination with an alternative water source. In another embodiment (not shown), only an alternative water source is used. In another embodiment (not shown), algae production **1000** is supplied with heat from a supply heat source **1055**. In another illustrated embodiment, the waste heat output **1090** is one of: an air cooler, a water tower, an exhaust stack, a cooling tower, a heat sink, and the like. In an alternative embodiment (not shown), the waste heat source **1060** is combined with a CO₂ exhaust supply and hot gas **1085** and then injected into the body of water **1020**. The algae production of **Figure 10** may contain any or all of the disclosed embodiments and disclosed alternative embodiments of **Figures 1-9** discussed above.

[0062] **Figures 11-14** are embodiments of heat exchangers incorporated in the embodiments above and included as heat transfer devices in the definitions above. **Figure 11** is a heat exchanger that has a built in fan(s) that act as a fluid mover to increase flow of supply heat, recovered heat, or waste heat so heat transfer is increased.

Figure 12 are examples of plate heat exchangers. Flow 1 represents a warm fluid and flow 2 represents a cooler fluid that is to be heated by the transfer of heat from fluid 1. **Figure 13** is an example of a shell and tube heat exchanger. In a shell and tube heat exchanger, the hot fluid moves through the shell of the heat exchanger and the gas or liquid to be heated moves through the tubes of the heat exchanger. Lastly, **Figure 14** is a schematic of a regenerative heat exchanger, also known as a countercurrent exchange, a regenerator, or an economizer. Regenerative heat exchangers come in plate or shell and tube forms. In another embodiment (not shown), a heat transfer device may include a condenser as found in a power plant. In yet another embodiment (not shown), heat from another industrial cooling technique is transferred to the body of water with algae in suspension using piping, duct work, and other fluid moving devices. **Figures 11-14** are not meant to be an exhaustive display of heat exchangers that one skilled in the art may likely use to transfer heat, but only as representative examples of types of heat exchangers that one skilled in the art may use to transfer heat into a heat consuming process or method.

[0063] **Figures 15-16** are examples of covers that are incorporated in the some of the embodiments above. Covers that may be incorporated in the embodiments above, include one of: gutter connected greenhouse, free standing or round greenhouse, round greenhouse with sides, gothic arch greenhouse, cover without a supporting structure, cover draped over center island divider, covers laid on water surfaces that have periodic floating sections that maintain a space between the cover and the surface of the body of water, covers supported only by a divider structure, and covers supported by a structure that includes a divider, cover supported over a structure, and a cover supported over a divider. In another embodiment (not shown), the cover is supported by at least one of: a structure, divider, and the like. In yet another embodiment (not shown), the support for the cover is partially from one of: a structure and divider. In another embodiment (not shown), the structure that supports the cover is made of at least one: earth, steel, aluminum, metal alloys, plastic, glass, polymeric material, fiberglass, dirt, soil, rock, and the like. The covers may have, at least one of: a support material, strapping, height divider, height structure, support strapping over cover, and support strapping below cover.

In another embodiment (not shown), the cover incorporates a structure that allows for a mixer.

[0064] While the systems, methods, and so on have been illustrated by describing examples, and while the examples have been described in considerable detail, it is not the intention of the applicants to restrict or in any way limit the scope of the appended claims to such detail. It is, of course, not possible to describe every conceivable combination of components or methodologies for purposes of describing the systems, methods, and so on provided herein. Additional advantages and modifications will readily appear to those skilled in the art. Therefore, the invention, in its broader aspects, is not limited to the specific details, the representative system or method, and illustrative examples shown and described. Accordingly, departures may be made from such details without departing from the spirit or scope of the applicant's general inventive concept. Thus, this application is intended to embrace alterations, modifications, and variations that fall within the scope of the appended claims. Furthermore, the preceding description is not meant to limit the scope of the invention. Rather, the scope of the invention is to be determined by the appended claims and their equivalents.

[0065] To the extent that the term "includes" or "including" is employed in the detailed description or the claims, it is intended to be inclusive in a manner similar to the term "comprising" as that term is interpreted when employed as a transitional word in a claim. Furthermore, to the extent that the term "or" is employed in the claims (e.g., A or B) it is intended to mean "A or B or both". When the applicants intend to indicate "only A or B but not both" then the term "only A or B but not both" will be employed. Similarly, when the applicants intend to indicate "one and only one" of A, B, or C, the applicants will employ the phrase "one and only one". Thus, use of the term "or" herein is the inclusive, and not the exclusive use.

CLAIMS

What is claimed is:

1. A method of producing algae, comprising:
 - providing at least one body of water having an algae population in suspension, wherein the body of water has an environment that is monitored for at least one of: nitrogen, nitrates, nitrogen containing substances, phosphorous, phosphates, phosphorous containing substances, potassium, potassium containing substances, silicon, silica, silicates, silicon containing substances, partial pressure of carbon dioxide, pH, temperature, and population density of the algae population in suspension;
 - heating the body of water with a heat source; wherein the heat source comprises at least one of: a supply heat source, a recovered heat source, and a waste heat source from at least one of: a power plant, an industrial process, a cement plant, a kiln, an agricultural product processing plant, a processing plant, an incinerator, a furnace, an oven, an oil refinery, a petrochemical plant, a chemical plant, an ethanol plant, an amine treating plant, a natural gas processing plant, a steel plant, a metals plant, an ammonia plant, a coal gasification plant, a refinery, a liquid synthetic fuel plant, a gas synthetic fuel plant, an industrial plant, and a manufacturing plant; and
 - growing the algae population.
2. The method of claim 1, wherein the algae population in suspension is a local population that is found within a distance less than or equal to one-hundred and fifty miles from an algae production site.
3. The method of claim 1, wherein the algae population in suspension is a foreign population that is found a distance greater than one-hundred and fifty miles from an algae production site or that is genetically modified.
4. The method of claim 1, wherein the heating the body of water with a heat source comprises transmitting heat by at least one of: hot gas to a heat

exchanger located in the body of water that transmits heat into the body of water, hot gas to a heat exchanger located in proximity to the body of water that transfers heat to and into the body of water, hot gas injection into the body of water, hot vapor injection into the body of water, hot vapor to a heat exchanger in the body of water that transfers heat into the body of water, hot vapor to a heat exchanger located in proximity to the body of water that transfers heat to and into the body of water, hot liquid injection directly into the body of water, hot liquid transmitted to a heat exchanger located in the body of water that transfers heat into the body of water, hot liquid transmitted to a heat exchanger located in proximity to the body of water that transfers heat to and into the body of water, body of water fluid transmitted to a heat exchanger located in the industrial process that transfers heat to the body of water fluid which is then returned to the body of water, body of water fluid transmitted to a heat exchanger located in proximity to the industrial process that transfers heat to the body of water fluid which is then returned to the body of water, hot vapor transmitted to the body of water in a pipe or a duct that transfers heat into the body of water through the pipe or the duct, hot gas transmitted to the body of water in a pipe or a duct that transfers heat into the body of water through the pipe or the duct, and hot liquid transmitted to the body of water in a pipe or a duct that transfers heat into the body of water through the pipe or the duct.

5. The method of claim 1, further comprising operatively connecting the body of water with the heat source by at least one of: a pipe, a duct work, a pump, a fan, an injector, a nozzle, a heat exchanger, a valve, a control, a monitor, an injector, and a nozzle.
6. The method of claim 1, further comprising covering the body of water with a cover at least partially supported by a structure.
7. A method of producing algae, comprising:

processing algae with a heat source; wherein the heat source comprises at least one of: a supply heat source, a recovered heat source, and a waste heat source from at least one of: a power plant, an industrial process, a cement plant, a kiln, an agricultural product processing plant, a processing plant, an incinerator, a furnace, an oven, an oil refinery, a petrochemical plant, a chemical plant, an ethanol plant, an amine treating plant, a natural gas processing plant, a steel plant, a metals plant, an ammonia plant, a coal gasification plant, a refinery, a liquid synthetic fuel plant, a gas synthetic fuel plant, an industrial plant, and a manufacturing plant.

8. The method of claim 7, further comprising providing at least one body of water having an algae population in suspension, wherein the body of water has an environment that is monitored for at least one of: nitrogen, nitrates, nitrogen containing substances, phosphorous, phosphates, phosphorous containing substances, potassium, potassium containing substances, silicon, silica, silicates, silicon containing substances, partial pressure of carbon dioxide, pH, temperature, and population density of the algae in suspension; and growing the algae population.
9. The method of claim 7, wherein the processing algae with a heat source further comprises drying algae with a full, a partial, or a supplemental heat from at least one of: a waste heat source, a recovered heat source, a supply heat source, a steam heat from an industrial process, and a steam heat from an algae production process.
10. The method of claim 7, wherein the processing algae with a heat source further comprises at least one body of water having an algae population in suspension, further comprising heating the body of water with a heat source; wherein the heat source comprises at least one of: a supply heat source, a recovered heat source, and a waste heat source from at least one of: a power plant, an industrial process, a cement plant, a kiln, an agricultural product processing plant, a processing plant, an incinerator, a furnace, an oven, an oil

refinery, a petrochemical plant, a chemical plant, an ethanol plant, an amine treating plant, a natural gas processing plant, a steel plant, a metals plant, an ammonia plant, a coal gasification plant, a refinery, a liquid synthetic fuel plant, a gas synthetic fuel plant, an industrial plant, and a manufacturing plant.

11. The method of claim 8, wherein algae population in suspension is from at least one of: a local population that is found within a distance less than or equal to one-hundred and fifty miles from an algae production site and a foreign population that is found a distance greater than one-hundred and fifty miles from an algae production site or that is genetically modified.

12. A heat recovery system, comprising:

at least one heat source; wherein the heat source comprises at least one of: a supply heat source, a recovered heat source, and a waste heat source from at least one of: a power plant, an industrial process, a cement plant, a kiln, an agricultural product processing plant, a processing plant, an incinerator, a furnace, an oven, an oil refinery, a petrochemical plant, a chemical plant, an ethanol plant, an amine treating plant, a natural gas processing plant, a steel plant, a metals plant, an ammonia plant, a coal gasification plant, a refinery, a liquid synthetic fuel plant, a gas synthetic fuel plant, an industrial plant, and a manufacturing plant;

at least one heat consuming process; wherein the at least one heat consuming process is at least one of: a body of water with an algae in suspension, an algae drying process, an algae processing, an algae growing, an algae production, a photobioreactor;

at least one heat transmitting device; and

a plurality of fluid movers.

13. The system of claim 12, wherein the plurality of fluid movers is a plurality of one or more of: a pump, a fan, a mixer, a pipe, a duct work, an injector, a

nozzle, a damper, a valve, a supply of heat, a return of heat, and a fluid mover by-pass.

14. The system of claim 12, wherein the at least one heat consuming process is operatably connected to the source of heat by at least one of: hot gas to a heat exchanger located in the body of water that transmits heat into the body of water, hot gas to a heat exchanger located in proximity to the body of water that transfers heat to and into the body of water, hot gas injection into the body of water, hot vapor injection into the body of water, hot vapor to a heat exchanger in the body of water that transfers heat into the body of water, hot vapor to a heat exchanger located in proximity to the body of water that transfers heat to and into the body of water, hot liquid injection directly into the body of water, hot liquid transmitted to a heat exchanger located in the body of water that transfers heat into the body of water, hot liquid transmitted to a heat exchanger located in proximity to the body of water that transfers heat to and into the body of water, body of water fluid transmitted to a heat exchanger located in the industrial process that transfers heat to the body of water fluid which is then returned to the body of water, body of water fluid transmitted to a heat exchanger located in proximity to the industrial process that transfers heat to the body of water fluid which is then returned to the body of water, hot vapor transmitted to the body of water in a pipe or a duct that transfers heat into the body of water through the pipe or the duct, hot gas transmitted to the body of water in a pipe or a duct that transfers heat into the body of water through the pipe or the duct, and hot liquid transmitted to the body of water in a pipe or a duct that transfers heat into the body of water through the pipe or the duct.
15. The heat recovery system of claim 12, further comprising a cover wherein the cover comprises a material that allows passage of light, the material that allows passage of light comprising at least one of: plastic, polymeric material, glass, acrylic, and polycarbonate.

16. The system of claim 15, wherein the cover includes at least one of: insulation, single layer of covering, multiple layers of covering, multiple layers separated by a gas pocket of circulated or stagnant gas, an opening to allow heat removal, a vent for gaseous material removal, sections that can be removed from above the body of water, a retractable section, a removable panel, a roll-up section.
17. The system of claim 15, wherein the cover is at least one of: gutter connected, free standing, round house, round house with sides, gothic arch, gothic arch with sides, cover with strapping, cover without strapping, cover draped over divider, floating cover with structure over part of the water, floating cover that has a substantial portion not touching the water, cover supported only by divider structure, a cover supported by a structure including a divider, and a cover supported over a structure.
18. The system of claim 17, wherein the structure comprises at least one of: earth, steel, aluminum, metal alloy, plastic, glass, polymeric material, fiberglass, dirt, soil, sand, and rock.
19. A method of producing algae, comprising:
 - providing at least one body of water having an algae population in suspension, wherein the body of water has an environment that is monitored for at least one of: nitrogen, nitrates, nitrogen containing substances, phosphorous, phosphates, phosphorous containing substances, potassium, potassium containing substances, silicon, silica, silicates, silicon containing substances, partial pressure of carbon dioxide, pH, temperature, and population density of the algae in suspension;
 - covering the body of water with a cover at least partially supported by a structure; and
 - growing the algae population.

20. The method of claim 19, wherein the algae population in suspension is a local population that is found within a distance less than or equal to one-hundred and fifty miles from an algae production site.
21. The method of claim 19, wherein the algae population in suspension is a foreign population that is found a distance greater than one-hundred and fifty miles from an algae production site or that is genetically modified.
22. The method of claim 19, wherein the covering the body of water with a cover includes a cover made from a material that allows passage of light, the material that allows passage of light comprising at least one of: plastic, polymeric material, glass, acrylic, and polycarbonate.
23. The method of claim 19, wherein the cover includes at least one of: insulation, single layer of covering, multiple layers of covering, multiple layers separated by an air pocket of circulated or stagnant air, an opening to allow heat removal, a vent for gaseous material removal, sections that can be removed from above the body of water, a retractable section, a removable panel, a roll-up section.
24. The method of claim 19, wherein the cover is at least one of: gutter connected, free standing, round house, round house with sides, gothic arch, gothic arch with sides, cover with strapping, cover without strapping, cover draped over divider, floating cover with structure over part of the water, floating cover that has a substantial portion not touching the water, cover supported only by divider structure, a cover supported by a structure including a divider, a cover partially supported by a divider, floating cover with a structure over a mixer, a cover supported over a structure, cover supported by a structure including a photobioreactor.
25. The method of claim 19, wherein the structure comprises at least one of: earth, steel, aluminum, metal alloy, plastic, glass, polymeric material, fiberglass, dirt, soil, sand, and rock.

AMENDED CLAIMS

Received by the International Bureau on 27.Feb.2009 (27.02.2009)

What is claimed is:

1. (Once Amended) A method of producing algae (400), comprising:
 - providing at least one body of water (420) having an algae population (425) in suspension, wherein the body of water has an environment (495) that is monitored for at least one of: nitrogen, nitrates, nitrogen containing substances, phosphorous, phosphates, phosphorous containing substances, potassium, potassium containing substances, silicon, silica, silicates, silicon containing substances, partial pressure of carbon dioxide, pH, temperature, and population density of the algae population in suspension, wherein the body of water (420) comprises at least one of: a lake, a river, a natural pond, a man-made pond, a stream, and a pool;
 - heating the body of water (420) with a heat source; wherein the heat source comprises at least one of: a recovered heat source (415) and a waste heat source (460) from at least one of: a power plant, an industrial process (405), a cement plant, a kiln, an agricultural product processing plant, a processing plant, an incinerator, a furnace, an oven, an oil refinery, a petrochemical plant, a chemical plant, an ethanol plant, an amine treating plant, a natural gas processing plant, a steel plant, a metals plant, an ammonia plant, a coal gasification plant, a refinery, a liquid synthetic fuel plant, a gas synthetic fuel plant, an industrial plant, and a manufacturing plant,
 - wherein the heating the body of water (420) with a heat source comprises transmitting heat by at least one of: hot gas to a heat exchanger (470) located in the body of water (420) that transmits heat into the body of water, hot gas injection into the body of water (420), hot vapor injection into the body of water (420), hot vapor to a heat exchanger (470) in the body of water (420) that transfers heat into the body of water (420), hot liquid transmitted to a heat exchanger (470) located in the body of water (420) that transfers heat into the body of water (420), hot vapor transmitted to the body of water (420) in a pipe or a duct (470) that transfers heat into the body of water (420) through the pipe or the duct (470), hot gas transmitted to the body of water (420) in a pipe or a duct (470) that transfers heat into the body

of water (420) through the pipe or the duct (470), and hot liquid transmitted to the body of water (420) in a pipe or a duct (470) that transfers heat into the body of water (420) through the pipe or the duct (470); and

growing the algae population (425).

2. (Once Amended) The method (400) of claim 1, wherein the algae population (425) in suspension is a local population that is found within a distance less than or equal to one-hundred and fifty miles from an algae production site.
3. (Once Amended) The method (400) of claim 1, wherein the algae population (425) in suspension is a foreign population that is found a distance greater than one-hundred and fifty miles from an algae production site or that is genetically modified.
4. (Once Amended) The method (400) of claim 1, wherein the heat source further comprises a supply heat source (455).
5. (Once Amended) The method (400) of claim 1, further comprising operatively connecting the body of water (420) with the heat source by at least one of: a pump, a fan, an injector, a valve, a control, and a nozzle.
5. (Once Amended) The method (400) of claim 1, further comprising covering the body of water (420) with a cover (435) that allows passage of light, wherein the cover (435) is at least partially supported by a support mechanism (480) that comprises a divider, wherein the divider supports the cover (435) so the cover (435) is separated from the water (420) by a gap.
7. (Once Amended) A method (400) of producing algae, comprising:
processing algae (850) with a heat source; wherein the heat source comprises at least one of: a recovered heat source (415) and a waste heat source (460) from at least one of: a power plant, an industrial process, a cement plant, a kiln, an

agricultural product processing plant, a processing plant, an incinerator, a furnace, an oven, an oil refinery, a petrochemical plant, a chemical plant, an ethanol plant, an amine treating plant, a natural gas processing plant, a steel plant, a metals plant, an ammonia plant, a coal gasification plant, a refinery, a liquid synthetic fuel plant, a gas synthetic fuel plant, an industrial plant, and a manufacturing plant.

- i. (Once Amended) The method (400) of claim 7, further comprising providing at least one body of water (420) having an algae population (425) in suspension, wherein the body of water (420) has an environment (495) that is monitored for at least one of: nitrogen, nitrates, nitrogen containing substances, phosphorous, phosphates, phosphorous containing substances, potassium, potassium containing substances, silicon, silica, silicates, silicon containing substances, partial pressure of carbon dioxide, pH, temperature, and population density of the algae in suspension; and growing the algae population (425), wherein the body of water (420) comprises at least one of: a lake, a river, a natural pond, a man-made pond, a stream, and a pool.
9. (Once Amended) The method (400) of claim 7, wherein the processing algae (850) with a heat source further comprises drying algae with a full, a partial, or a supplemental heat from at least one of: a waste heat source (460), a recovered heat source (415), and a steam heat from an industrial process.
10. (Once Amended) The method (400) of claim 7, wherein the processing algae (850) with a heat source further comprises at least one body of water (420) having an algae population (425) in suspension, further comprising heating the body of water (420) with a heat source; wherein the heat source comprises at least one of: a recovered heat source (415) and a waste heat source (460) from at least one of: a power plant, an industrial process, a cement plant, a kiln, an agricultural product processing plant, a processing plant, an incinerator, a furnace, an oven, an oil refinery, a petrochemical plant, a chemical plant, an ethanol plant, an amine treating plant, a natural gas processing plant, a steel plant, a metals plant, an

ammonia plant, a coal gasification plant, a refinery, a liquid synthetic fuel plant, a gas synthetic fuel plant, an industrial plant, and a manufacturing plant;

wherein the heating the body of water (420) with a heat source comprises transmitting heat by at least one of: hot gas to a heat exchanger (470) located in the body of water (420) that transmits heat into the body of water (420), hot gas injection into the body of water (420), hot vapor injection into the body of water (420), hot vapor to a heat exchanger (470) in the body of water (420) that transfers heat into the body of water (420), hot liquid transmitted to a heat exchanger (470) located in the body of water (420) that transfers heat into the body of water (420), body of water (420) fluid transmitted to a heat exchanger (470) located in the industrial process (405) that transfers heat to the body of water (420) fluid which is then returned to the body of water (420), body of water (420) fluid transmitted to a heat exchanger (470) located in proximity to the industrial process (405) that transfers heat to the body of water (420) fluid which is then returned to the body of water (420), hot vapor transmitted to the body of water (420) in a pipe or a duct (470) that transfers heat into the body of water (420) through the pipe or the duct (470), hot gas transmitted to the body of water (420) in a pipe or a duct (470) that transfers heat into the body of water (420) through the pipe or the duct (470), and hot liquid transmitted to the body of water (420) in a pipe or a duct (470) that transfers heat into the body of water (420) through the pipe or the duct (470).

11. (Once Amended) The method (400) of claim 8, wherein algae population (425) in suspension is a local population that is found within a distance less than or equal to one-hundred and fifty miles from an algae production site.
12. (Once Amended) A heat recovery system (400), comprising:

at least one heat source; wherein the heat source comprises at least one of: a recovered heat source (415) and a waste heat source (460) from at least one of: a power plant, an industrial process (405), a cement plant, a kiln, an agricultural

product processing plant, a processing plant, an incinerator, a furnace, an oven, an oil refinery, a petrochemical plant, a chemical plant, an ethanol plant, an amine treating plant, a natural gas processing plant, a steel plant, a metals plant, an ammonia plant, a coal gasification plant, a refinery, a liquid synthetic fuel plant, a gas synthetic fuel plant, an industrial plant, and a manufacturing plant;

at least one heat consuming process (420); wherein the at least one heat consuming process (420) is at least one of: an algae drying process, algae processing (450), growing algae, algae production, a body of water (420) with an algae (425) in suspension where the body of water (420) comprises at least one of: a lake, a river, a natural pond, a man-made pond, a stream, and a pool;

at least one heat transmitting device (470); and

a plurality of fluid movers,

wherein the at least one heat transmitting device (470) comprises transmitting heat by at least one of: hot gas to a heat exchanger (470) located in the at least one heat consuming process (420) that transmits heat into the at least one heat consuming process (420), hot gas injection into the at least one heat consuming process (420), hot vapor injection into the at least one heat consuming process (420), hot vapor to a heat exchanger (470) in the at least one heat consuming process (420) that transfers heat into the at least one heat consuming process (420), hot liquid transmitted to a heat exchanger (470) located in the at least one heat consuming process (420) that transfers heat into the at least one heat consuming process (420), hot vapor transmitted to the at least one heat consuming process (420) in a pipe or a duct (470) that transfers heat into the at least one heat consuming process (420) through the pipe or the duct (470), hot gas transmitted to the at least one heat consuming process (420) in a pipe or a duct (470) that transfers heat into the at least one heat consuming process (420) through the pipe or the duct (470), and hot liquid transmitted to the at least one heat consuming

- process (420) in a pipe or a duct (470) that transfers heat into the at least one heat consuming process (420) through the pipe or the duct (470).
13. (Once Amended) The system (400) of claim 12, wherein the plurality of fluid movers is a plurality of one or more of: a pump, a fan, a mixer, an injector, a damper, a valve, a supply of heat, a return of heat, and a fluid mover by-pass.
 14. (Once Amended) The system (400) of claim 12, wherein the heat source further comprises a supply heat source (455).
 15. (Once Amended) The heat recovery system (400) of claim 12, further comprising a cover (435) wherein the cover (435) comprises a material that allows passage of light and the cover (435) is at least partially supported by a support mechanism (480) that comprises a divider that supports the cover (435) so the cover is separated from the water (420) by a gap, and wherein the material that allows passage of light comprises at least one of: plastic, polymeric material, glass, acrylic, and polycarbonate.
 16. (Cancelled)
 17. (Cancelled)
 18. (Once Amended) The system (400) of claim 15, wherein the support mechanism (480) further comprises at least one of: earth, steel, aluminum, metal alloy, plastic, glass, polymeric material, fiberglass, dirt, soil, sand, and rock.
 19. (Once Amended) A method of producing algae (400), comprising:
 - providing at least one body of water (420) having an algae population (425) in suspension, wherein the body of water (420) has an environment (495) that is monitored for at least one of: nitrogen, nitrates, nitrogen containing substances, phosphorous, phosphates, phosphorous containing substances, potassium, potassium containing substances, silicon, silica, silicates, silicon containing

substances, partial pressure of carbon dioxide, pH, temperature, and population density of the algae in suspension, wherein the body of water comprises at least one of: a lake, a river, a natural pond, a man-made pond, a stream, and a pool;

covering the body of water with a cover (435) that comprises a material that allows passage of light, wherein the cover is at least partially supported by a support mechanism (480) that comprises a divider that supports the cover (435) so the cover is separated from the water (420) by a gap, the material that allows passage of light comprising at least one of: plastic, polymeric material, glass, acrylic, and polycarbonate, wherein the divider divides the at least one body of water; and

growing the algae population (425).

20. (Once Amended) The method (400) of claim 19, wherein the algae population (425) in suspension is a local population that is found within a distance less than or equal to one-hundred and fifty miles from an algae production site.
21. (Once Amended) The method (400) of claim 19, wherein the algae population (425) in suspension is a foreign population that is found a distance greater than one-hundred and fifty miles from an algae production site or that is genetically modified.
22. (Once Amended) The method (400) of claim 19, further comprising heating the body of water (420) with a heat source; wherein the heat source comprises at least one of: a recovered heat source (415) and a waste heat source (460) from at least one of: a power plant, an industrial process, a cement plant, a kiln, an agricultural product processing plant, a processing plant, an incinerator, a furnace, an oven, an oil refinery, a petrochemical plant, a chemical plant, an ethanol plant, an amine treating plant, a natural gas processing plant, a steel plant, a metals plant, an ammonia plant, a coal gasification plant, a refinery, a liquid synthetic fuel plant, a gas synthetic fuel plant, an industrial plant, and a manufacturing plant,

wherein the heating the body of water (420) with a heat source comprises transmitting heat by at least one of: hot gas to a heat exchanger (470) located in the body of water (420) that transmits heat into the body of water (420), hot gas injection into the body of water (420), hot vapor injection into the body of water (420), hot vapor to a heat exchanger (470) in the body of water (420) that transfers heat into the body of water (420), hot liquid transmitted to a heat exchanger (470) located in the body of water (420) that transfers heat into the body of water (420), body of water (420) fluid transmitted to a heat exchanger (470) located in the industrial process (405) that transfers heat to the body of water (420) fluid which is then returned to the body of water (420), body of water (420) fluid transmitted to a heat exchanger (470) located in proximity to the industrial process (405) that transfers heat to the body of water (420) fluid which is then returned to the body of water (420), hot vapor transmitted to the body of water (420) in a pipe or a duct (470) that transfers heat into the body of water (420) through the pipe or the duct (470), hot gas transmitted to the body of water (420) in a pipe or a duct (470) that transfers heat into the body of water (420) through the pipe or the duct (470), and hot liquid transmitted to the body of water (420) in a pipe or a duct (470) that transfers heat into the body of water (420) through the pipe or the duct (470).

23. (Cancelled)
24. (Once Amended) The method (400) of claim 19, wherein the cover (435) further comprises at least one of: cover with strapping, cover without strapping, cover draped over divider (480), floating cover with structure over part of the water (420), floating cover that has a substantial portion not touching the water (420), cover (435) supported only by divider structure (480), floating cover (435) with a structure over a mixer, a cover (435) supported over a structure.
25. (Once Amended) The method (400) of claim 19, wherein the support mechanism (480) further comprises at least one of: earth, steel, aluminum, metal alloy, plastic, glass, polymeric material, fiberglass, dirt, soil, sand, and rock.

26. (New) The method (400) of claim 1, wherein the heating the body of water (420) with a heat source further comprises transmitting heat by at least one of: body of water (420) fluid transmitted to a heat exchanger (470) located in the industrial process (405) that transfers heat to the body of water (420) fluid which is then returned to the body of water (420), body of water (420) fluid transmitted to a heat exchanger (470) located in proximity to the industrial process (405) that transfers heat to the body of water (420) fluid which is then returned to the body of water (420).
27. (New) The method (400) of claim 12, wherein the at least one heat consuming process (420) further comprises a photobioreactor.
28. (New) The method (400) of claim 12, wherein the at least one heat consuming process (420) further comprises at least one of: heat consuming process (420) fluid transmitted to a heat exchanger (470) located in the industrial process (405) that transfers heat to the at least one heat consuming process (420) fluid which is then returned to the at least one heat consuming process (420) and at least one heat consuming process (420) fluid transmitted to a heat exchanger (470) located in proximity to the industrial process (405) that transfers heat to the at least one heat consuming process (420) fluid which is then returned to the at least one heat consuming process (420).

STATEMENT UNDER ARTICLE 19(1)

Applicant has amended claims 1-15, 18-22, 24, and 25 of the present application for purposes of clarification and to provide reference signs placed in parenthesis for the features in the claims. In addition, Applicant has cancelled claims 16, 17, and 23 and added new claims 26, 27, and 28. Support for the amendments and the new claims are provided in the description and in the drawings. The amendment to claims 1-15, 18-22, 24, and 25 and new claims 26, 27, and 28 have no impact on the description and the drawings since they are fully supported by the description and the drawings.

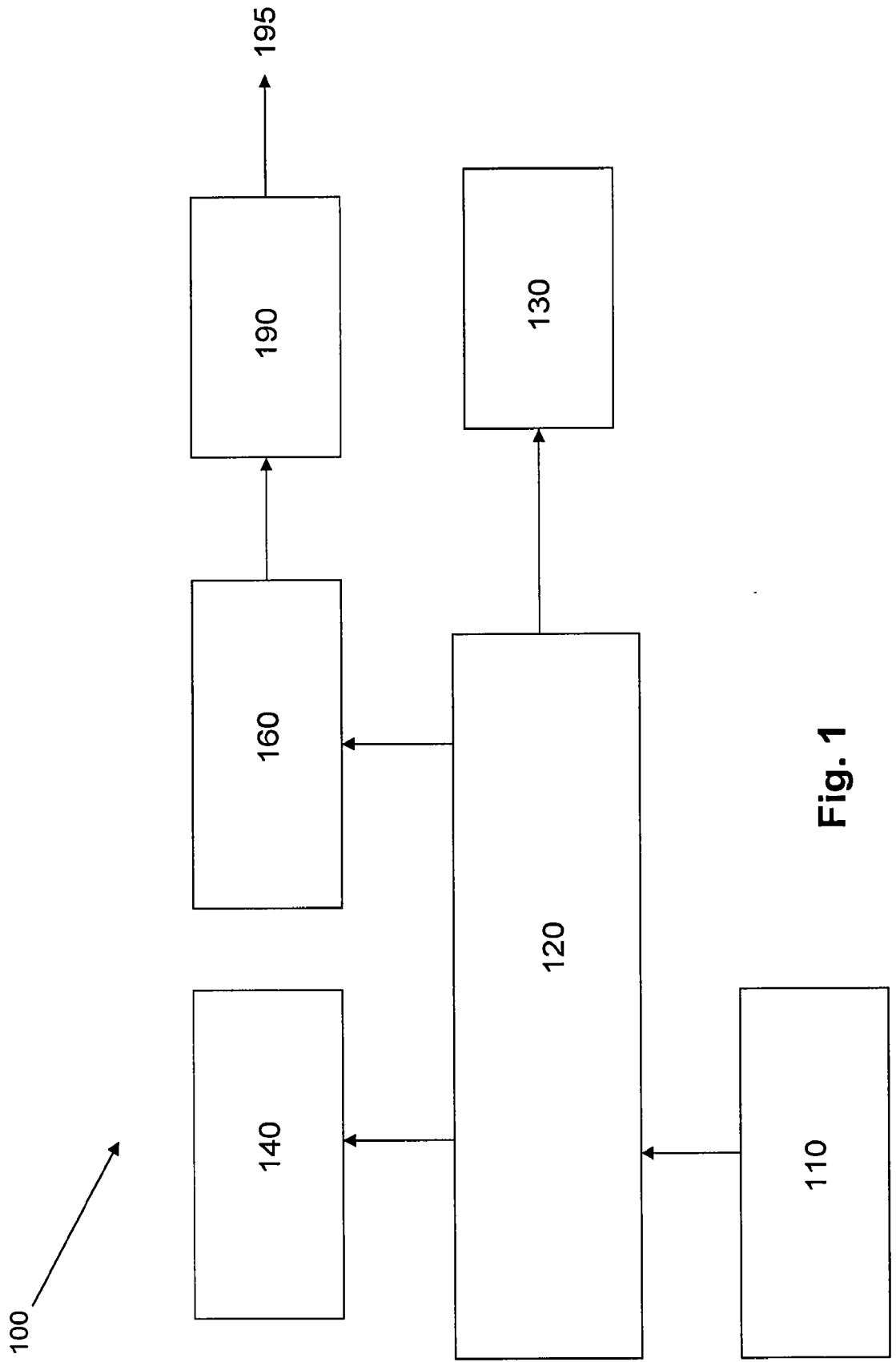

Fig. 1

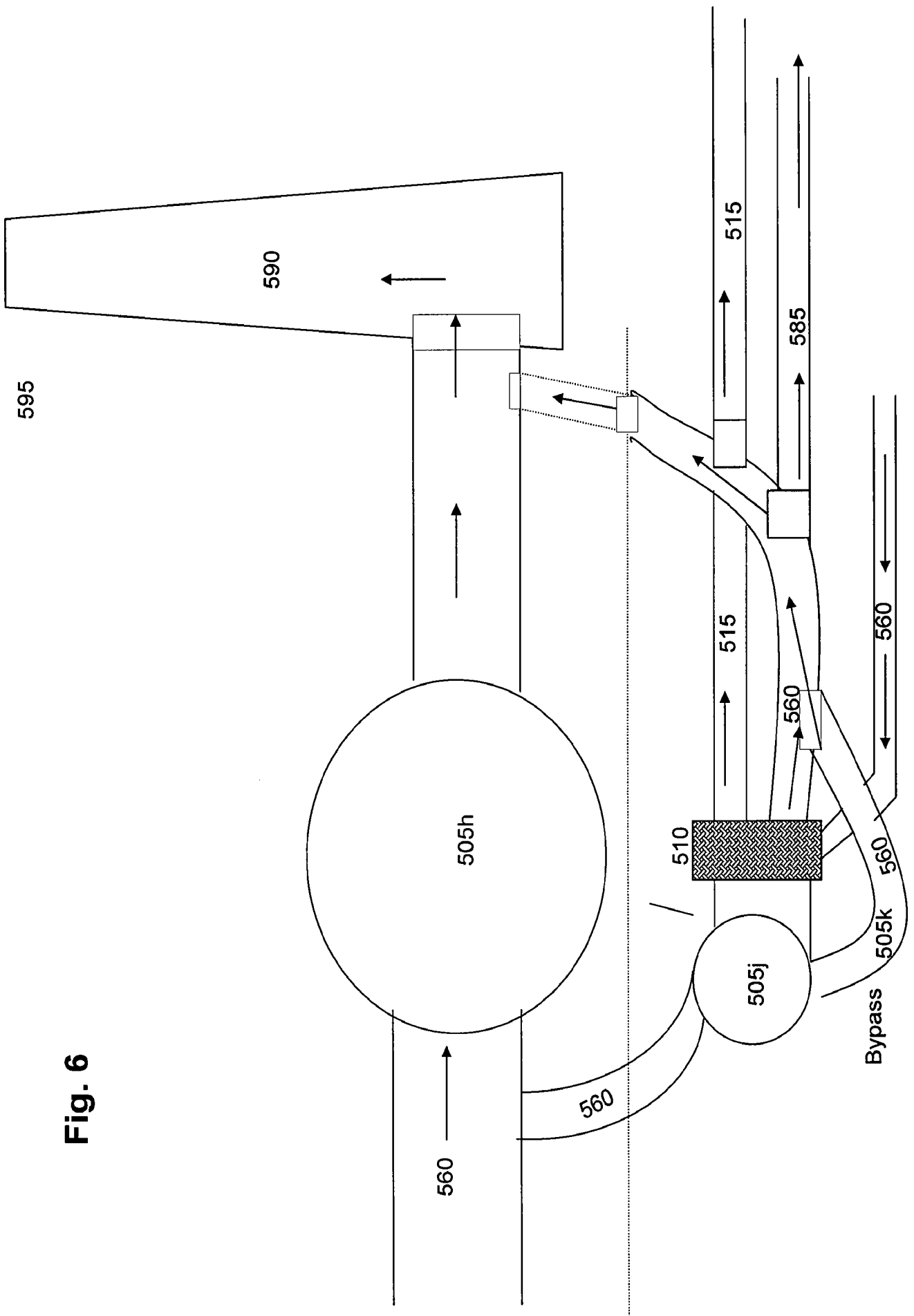
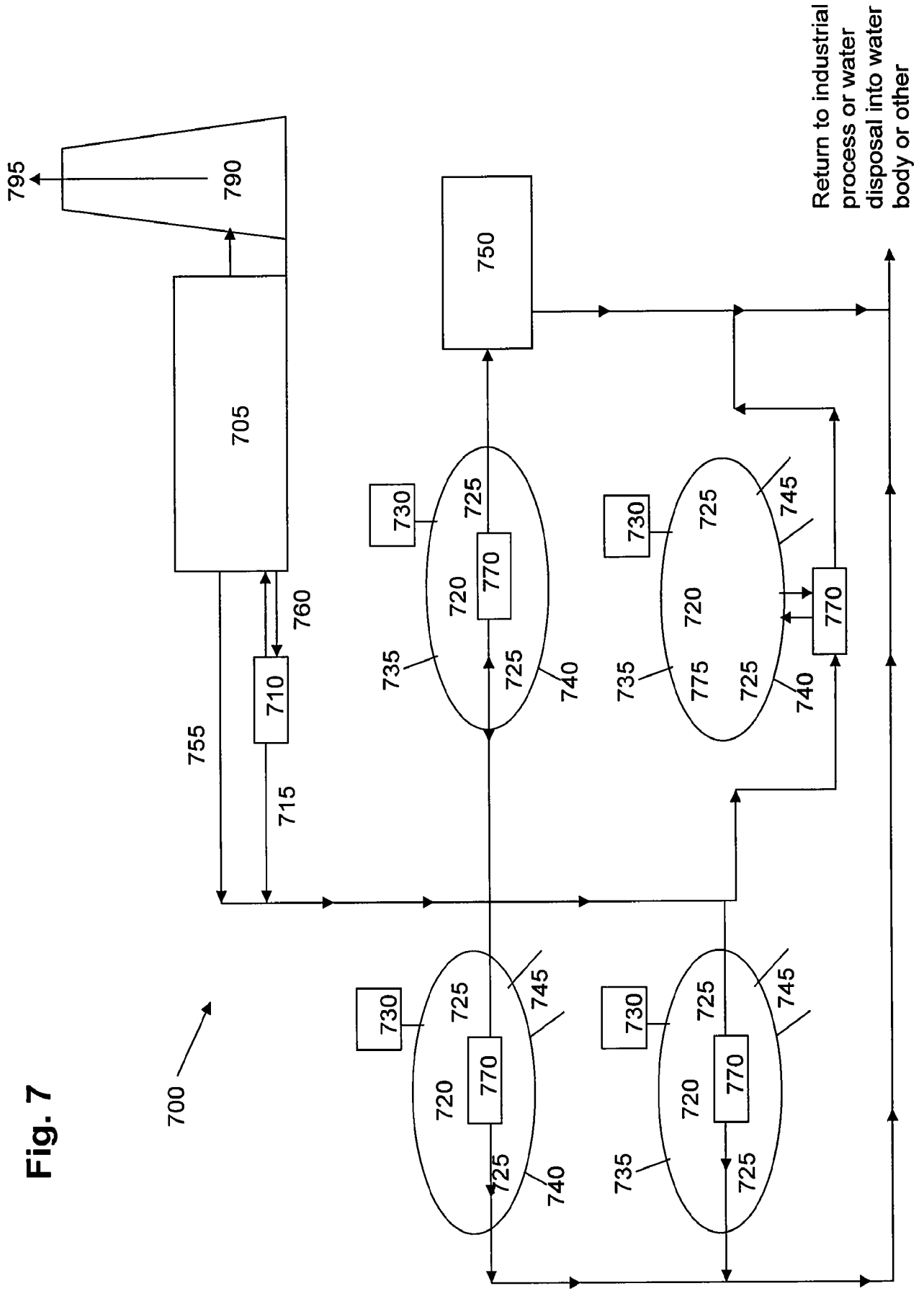

Fig. 6

Fig. 7



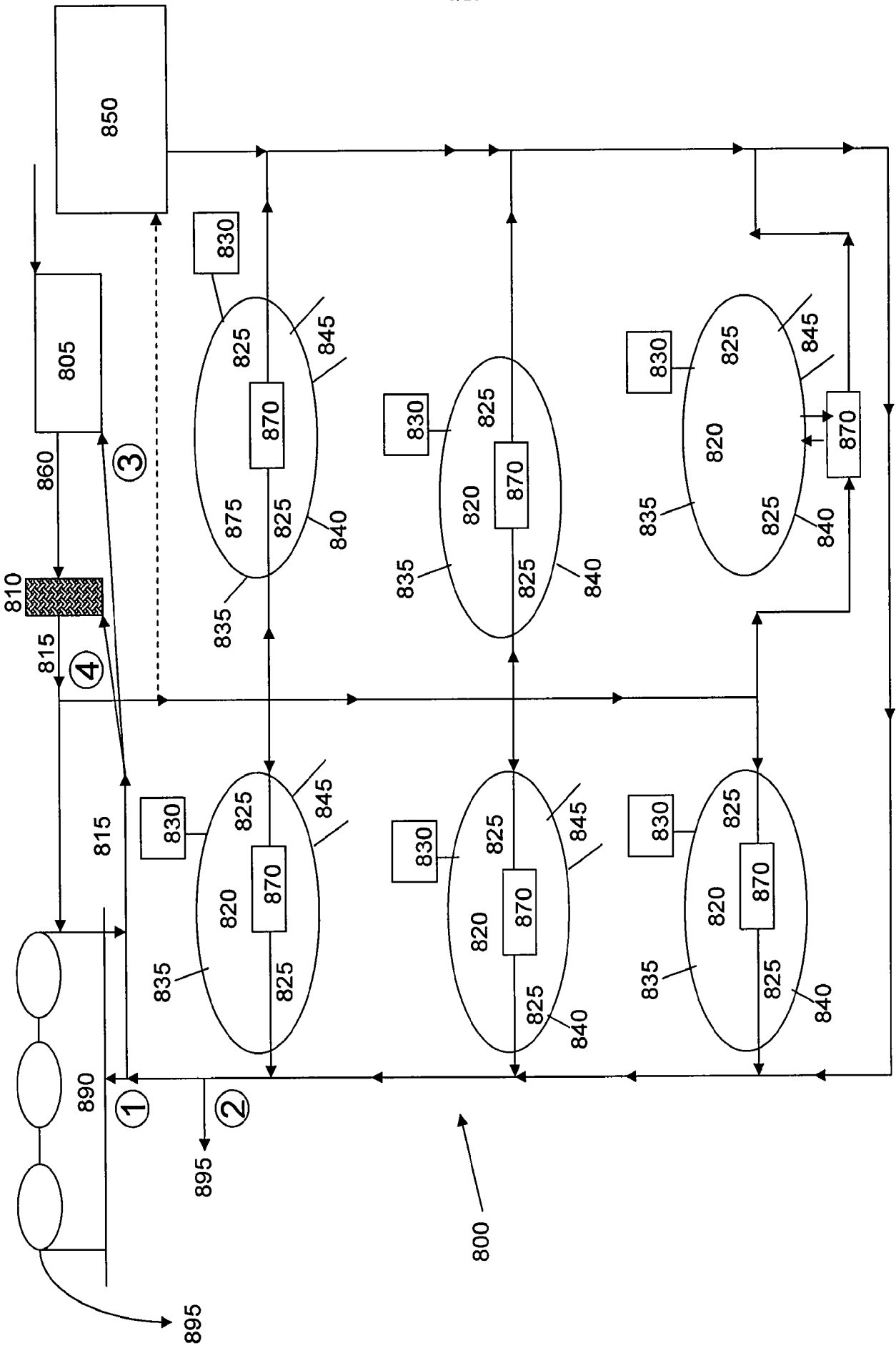

Fig. 8

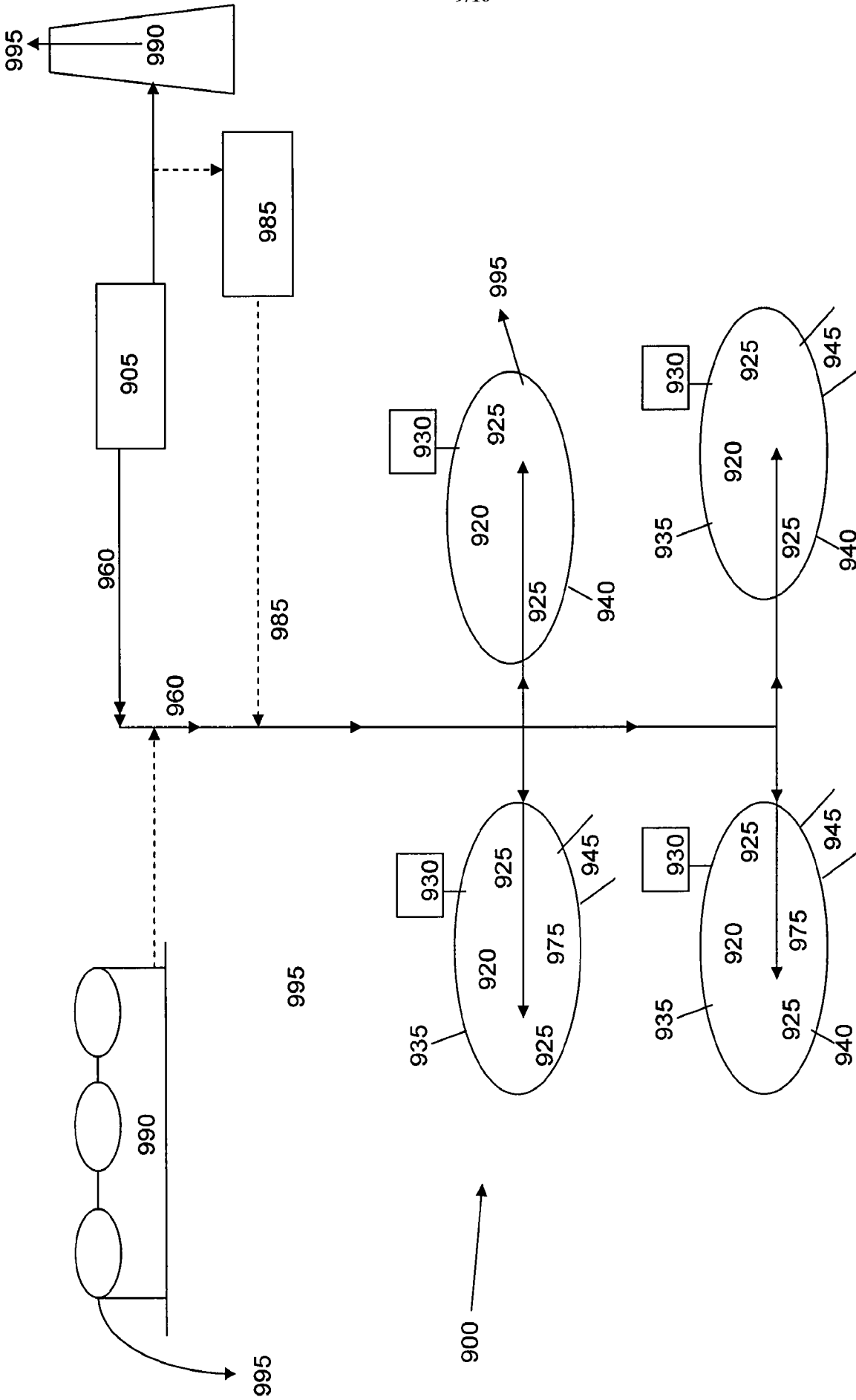

Fig. 9

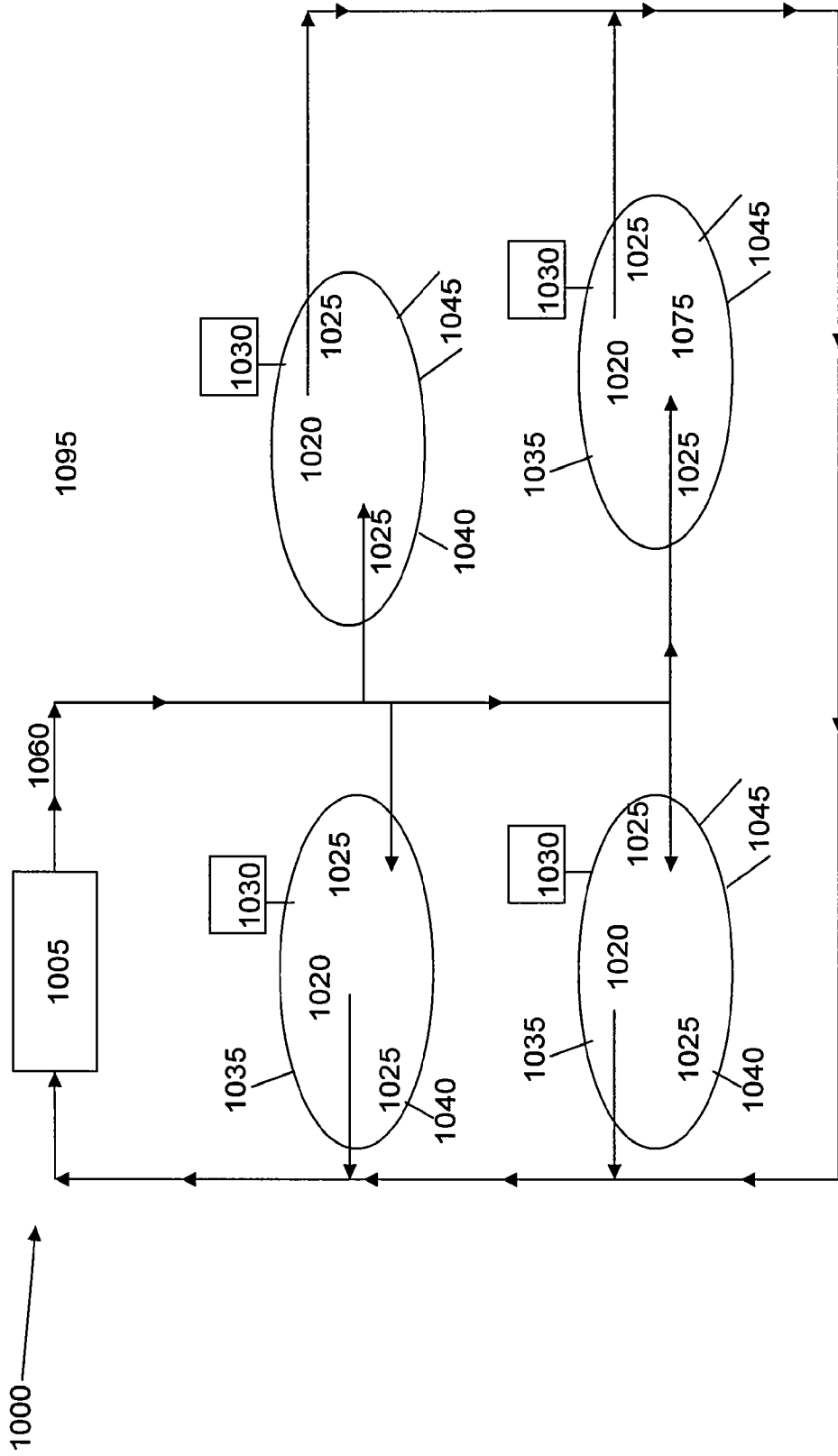

Fig. 10

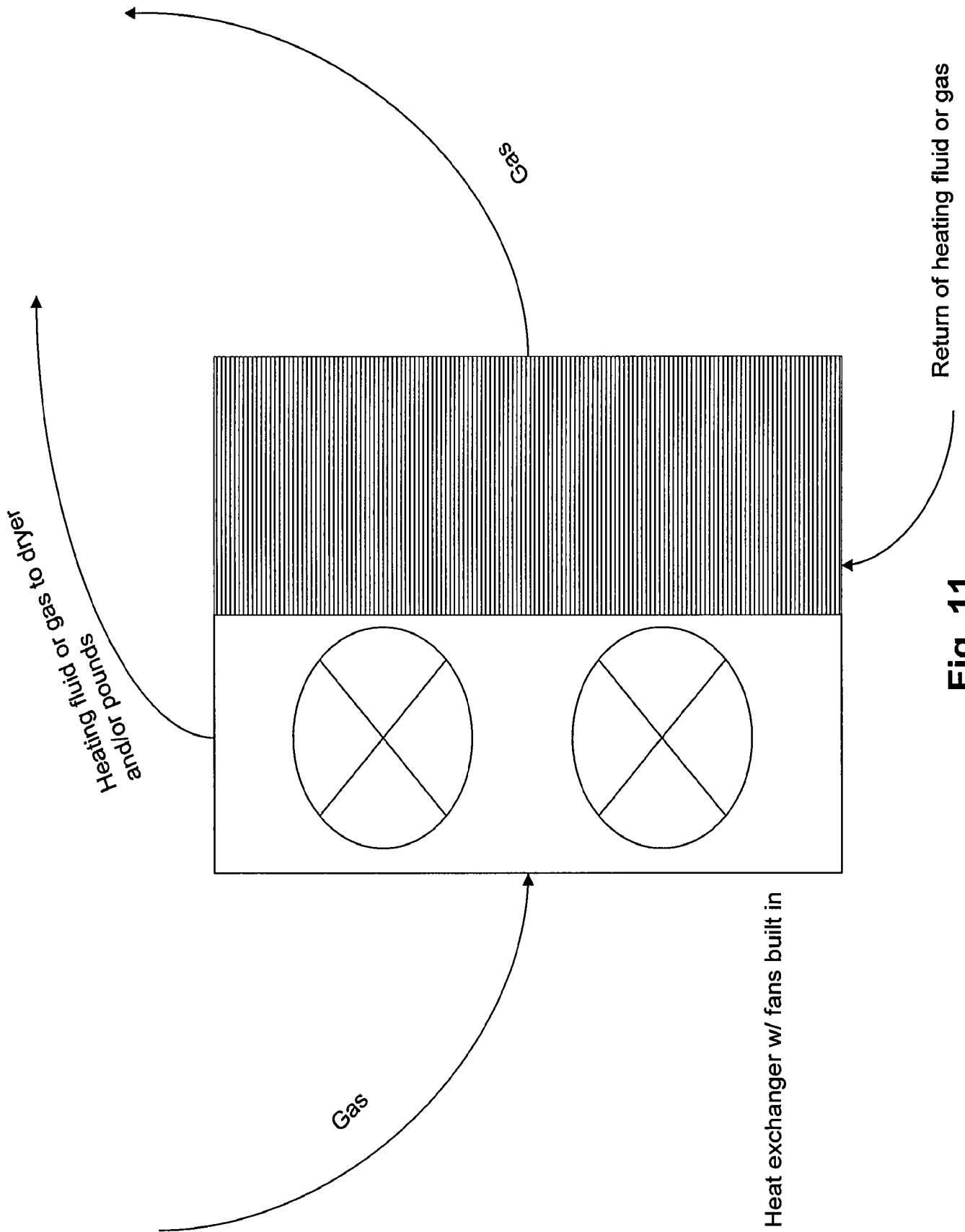

Fig. 11

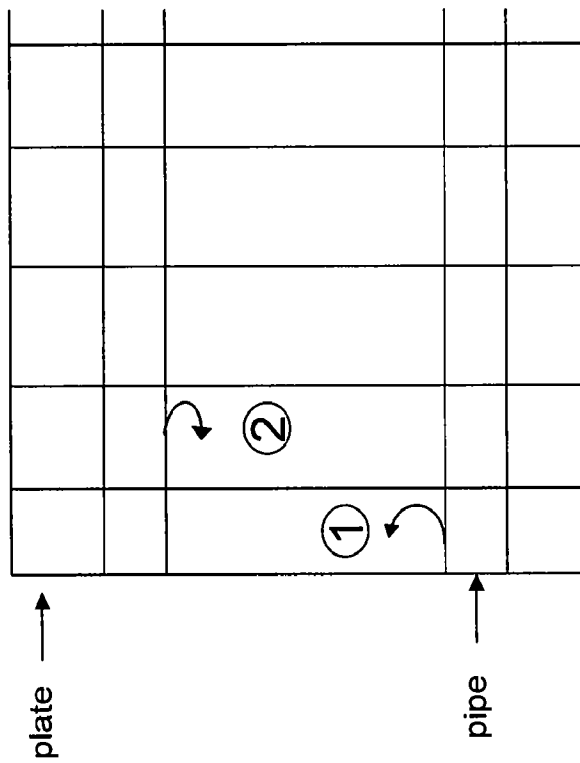
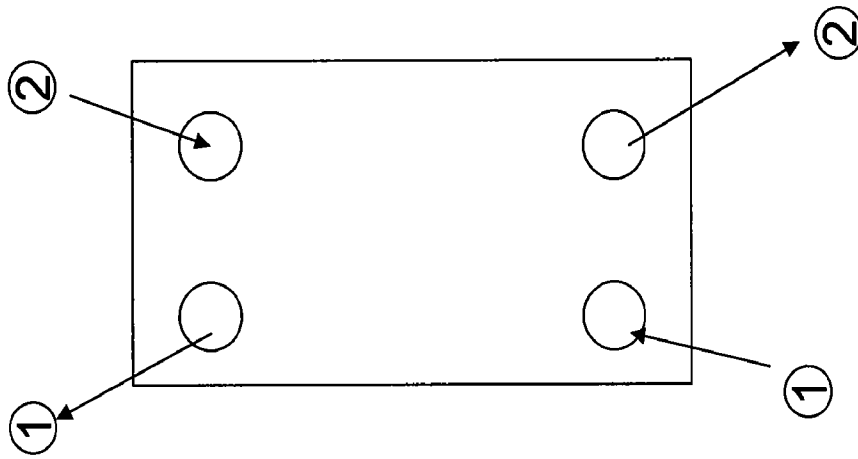

Fig. 12

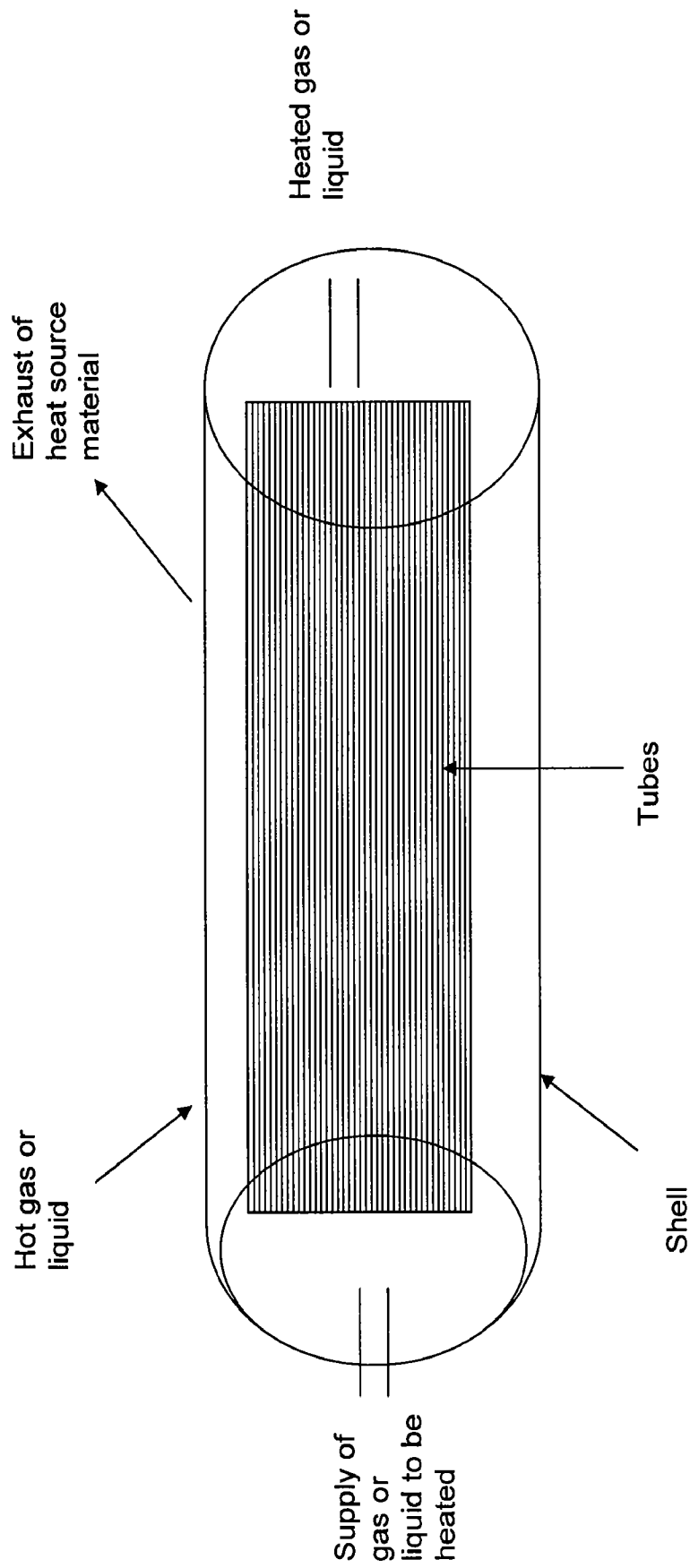

Fig. 13

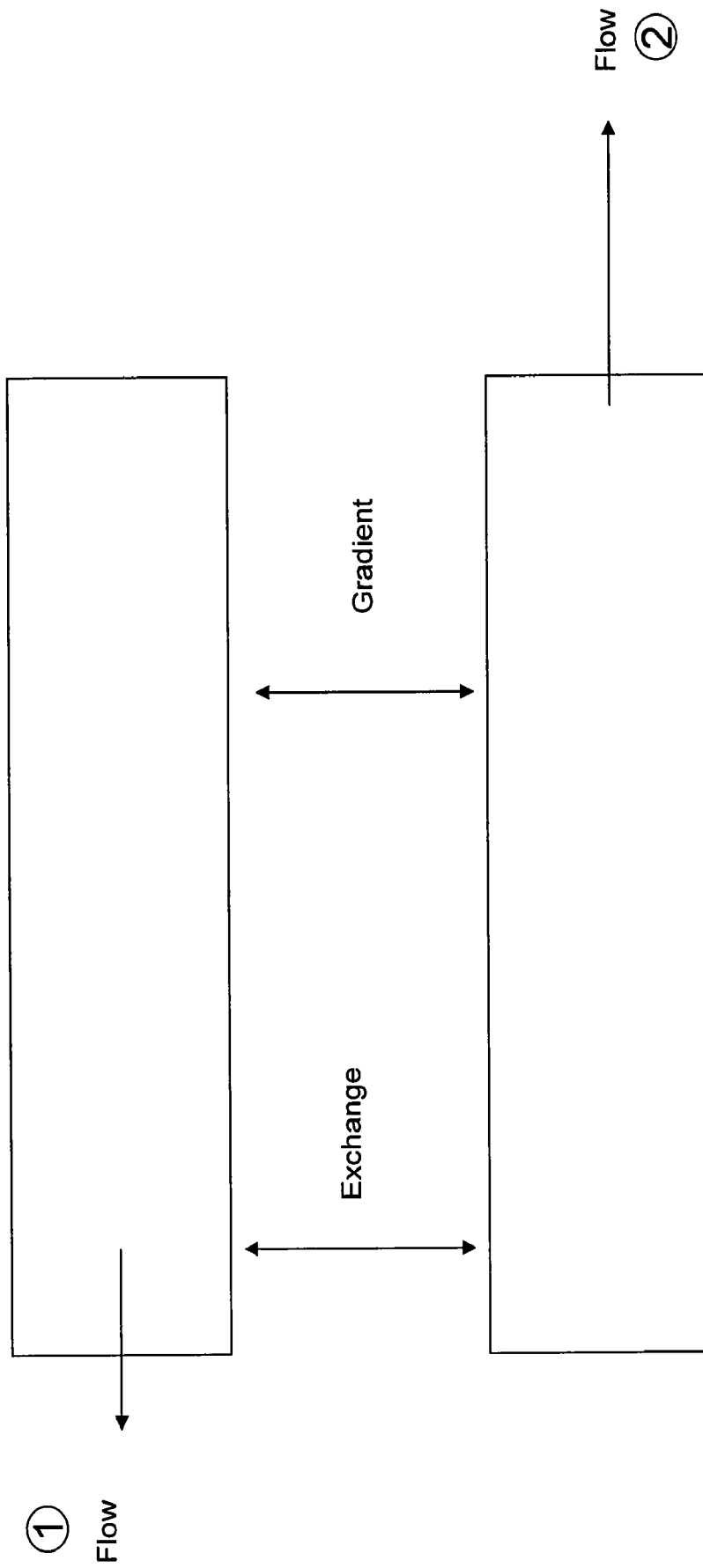

Fig. 14

15/16

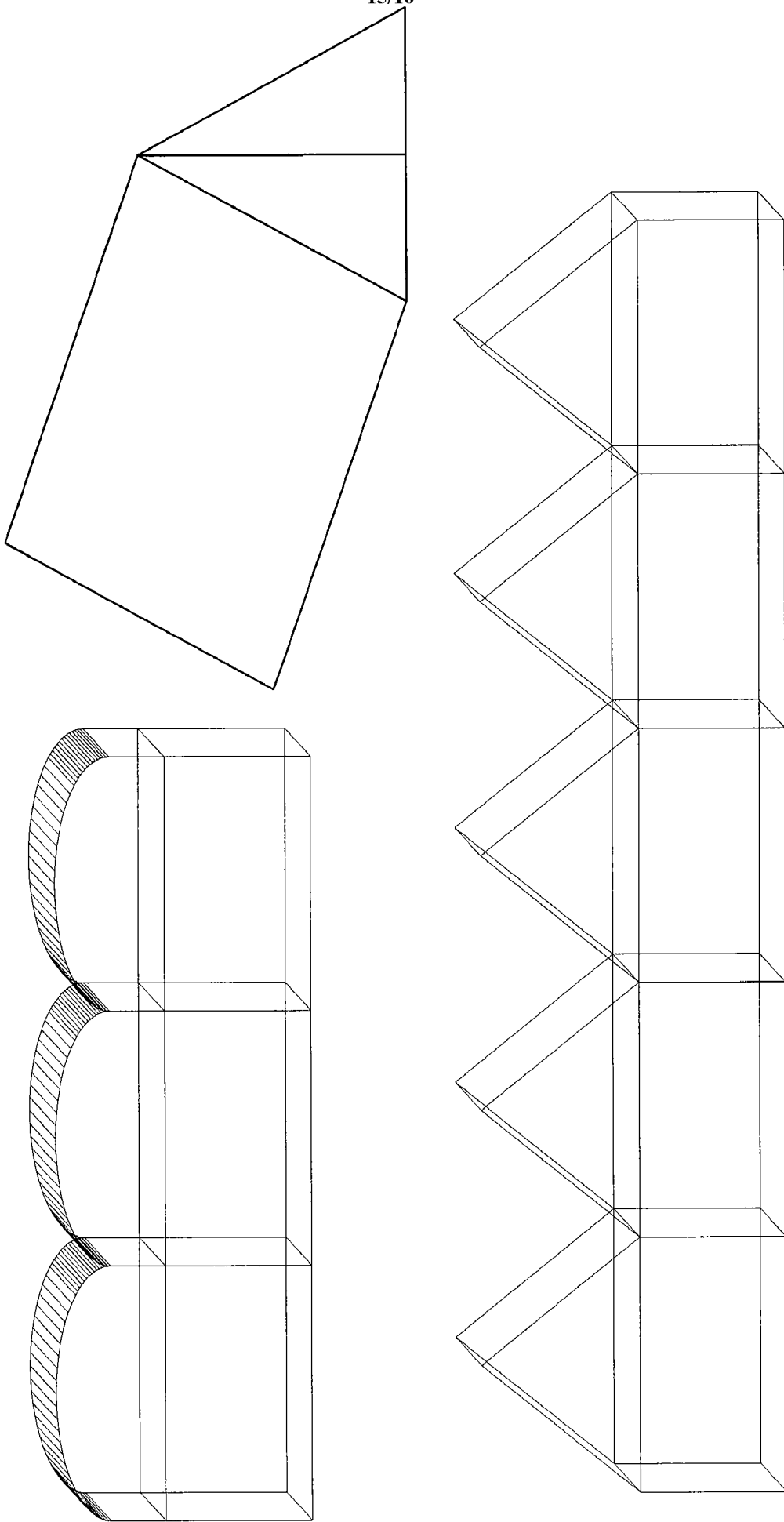

Fig. 15

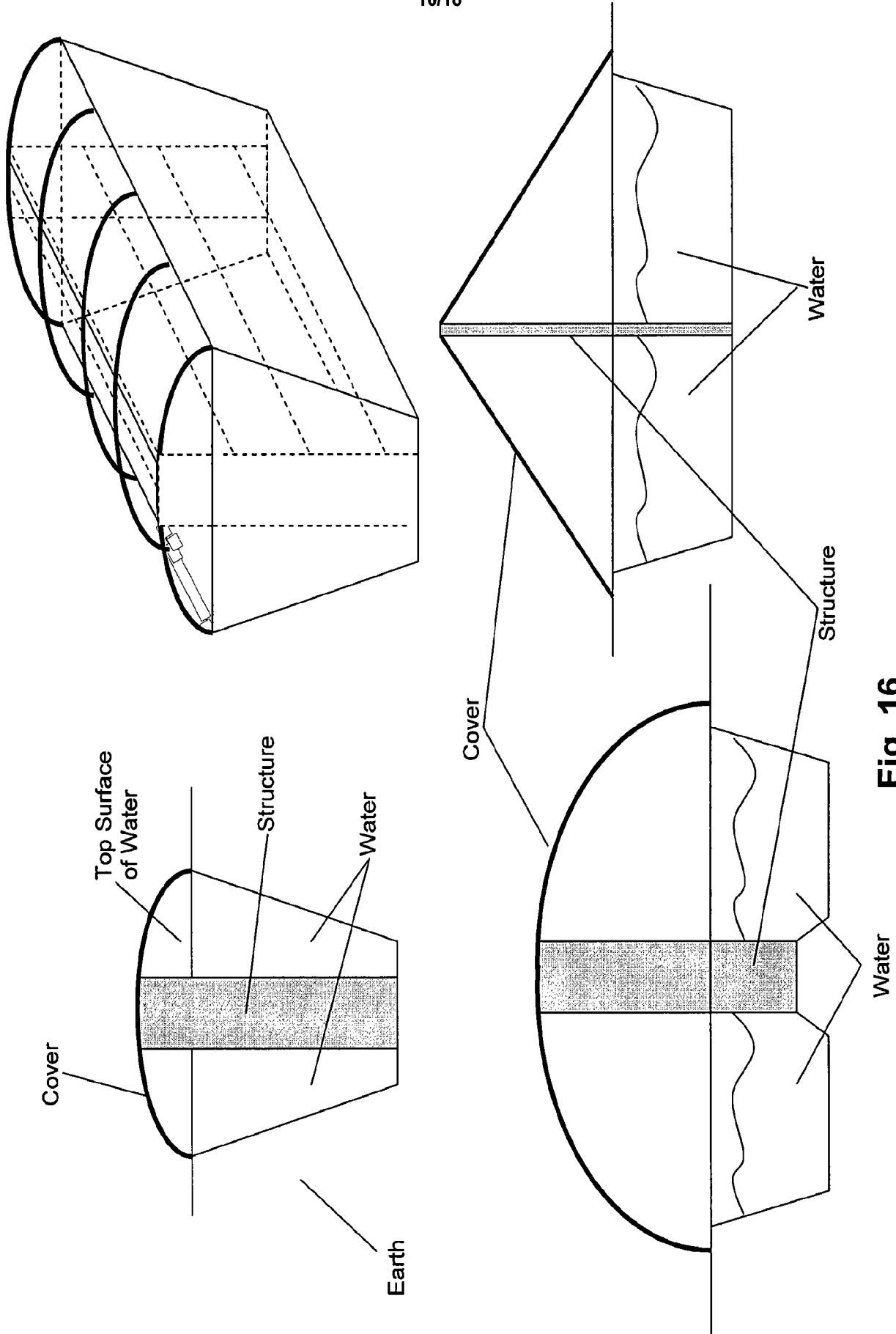

Fig. 16

INTERNATIONAL SEARCH REPORT

International application No.

PCT/US08/80674

A. CLASSIFICATION OF SUBJECT MATTER

IPC(8) - A01H 13/00 (2008.04)

USPC - 47/1.4

According to International Patent Classification (IPC) or to both national classification and IPC

B. FIELDS SEARCHED

Minimum documentation searched (classification system followed by classification symbols)

IPC(8): A01H 13/00 (2008.04)

USPC: 47/1.4

Documentation searched other than minimum documentation to the extent that such documents are included in the fields searched
J of Mar Biol Assn UK, Vol 84.

Electronic data base consulted during the international search (name of data base and, where practicable, search terms used)

WEST (PGPB,USPT,EPAB,JPAB): nitrogen, heat, algae, microalgae, exchanger, suspension, distance, population, plastic, cover, fiberglass, steel, refinery, furnace, oven, incinerator, foreign, dry; esp@cenet: algae, tank, cover; Google Scholar: culture, algae, nitrogen, heat; Google Patents: culturing, local, algae, population

C. DOCUMENTS CONSIDERED TO BE RELEVANT

Category*	Citation of document, with indication, where appropriate, of the relevant passages	Relevant to claim No.
X	US 4,320,594 A (RAYMOND) 23 March 1982 (23.03.1982); abstract; col 1, ln 8-9; col 3, ln 22-26; col 3, ln 46-47; col 3, ln 49-50; col 3, ln 65-68; col 5, ln 15-18; col 6, ln 2-5; col 6, ln 13-14;	19, 23, 24
Y	col 6, ln 40-50; col 8, ln 49-50; col 10, ln 12-15; col 10, ln 51-54; col 11, ln 15-17; col 13, ln 7-9; Fig 1; Fig 7.	1-18, 20-22, 25
Y	WILDE, EDWARD W. et al. Cultivation of algae and nutrient removal in a waste heat utilization process. 1991. J of Applied Phycology, Vol 3, page 159 (abstract), ISSN 0921-8971, [online], [retrieved on 2008-12-12], Retrieved from Internet: <URL: http://www.springerlink.com/content/j082761523326311/ >.	1-18
Y	GOLDBERG, NISSE et al. Highway or country road: algal recruitment with distance from an island reef. 2004. J of Mar Biol Assn UK, Vol 84, page 84 (abstract; right column, third full paragraph), ISSN 0025-3154.	2, 3, 11, 20, 21
Y	US 2002/0034817 A1 (HENRY et al.) 21 March 2002 (21.03.2002), para [0008].	9
Y	US 3,645,040 A (ORT) 29 February 1972 (29.02.1972), col 2, ln 2-4.	15-18, 22, and 25

 Further documents are listed in the continuation of Box C.

* Special categories of cited documents:

"A" document defining the general state of the art which is not considered to be of particular relevance

"E" earlier application or patent but published on or after the international filing date

"L" document which may throw doubts on priority claim(s) or which is cited to establish the publication date of another citation or other special reason (as specified)

"O" document referring to an oral disclosure, use, exhibition or other means

"P" document published prior to the international filing date but later than the priority date claimed

"T" later document published after the international filing date or priority date and not in conflict with the application but cited to understand the principle or theory underlying the invention

"X" document of particular relevance; the claimed invention cannot be considered novel or cannot be considered to involve an inventive step when the document is taken alone

"Y" document of particular relevance; the claimed invention cannot be considered to involve an inventive step when the document is combined with one or more other such documents, such combination being obvious to a person skilled in the art

"&" document member of the same patent family

Date of the actual completion of the international search

11 December 2008 (11.12.2008)

Date of mailing of the international search report

29 DEC 2008

Name and mailing address of the ISA/US

Mail Stop PCT, Attn: ISA/US, Commissioner for Patents
P.O. Box 1450, Alexandria, Virginia 22313-1450

Facsimile No. 571-273-3201

Authorized officer:

Lee W. Young

PCT Helpdesk: 571-272-4300
PCT DSP: 571-272-7774