

J. T. Williams,

Latch.

No. 107,578.

Patented Sep. 20. 1870.

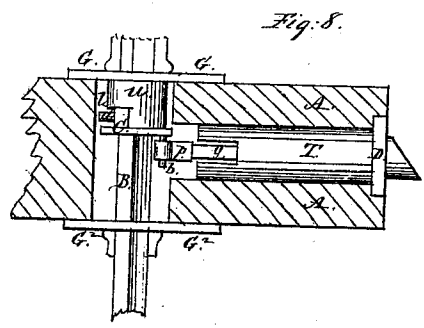
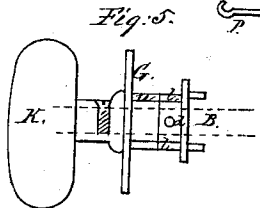
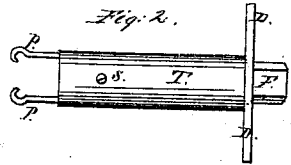
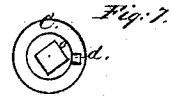
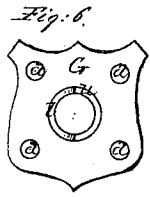
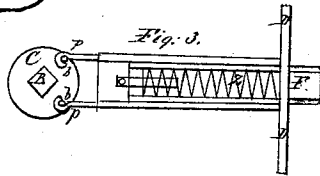
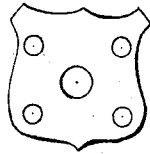
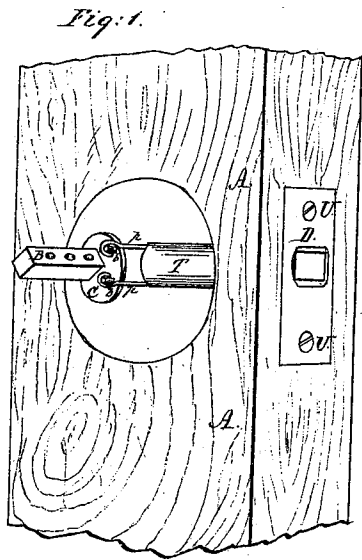

Witnesses.
Wm J Jacobs
James Houbert

Inventor
J. T. Williams

United States Patent Office.

JOHN THEOPHILUS WILLIAMS, OF CHICAGO, ILLINOIS.

Letters Patent No. 107,578, dated September 20, 1870.

IMPROVEMENT IN KNOB-LATCHES.

The Schedule referred to in these Letters Patent and making part of the same

To all whom it may concern :

Be it known that I, JOHN THEOPHILUS WILLIAMS, of the city of Chicago, in the county of Cook and State of Illinois, have invented a new and useful Improvement in a Knob-Latch, for latching doors; and I do hereby declare that the following is a full, clear, and exact description of the construction and operation of the same, reference being had to the annexed drawing making a part of this specification, in which—

Figure 1 is a perspective view of the door, with the latch applied, a section of the door being cut away to show the interior parts of the latch.

Figure 2, a longitudinal elevation of the latch removed from the door.

Figure 3, a longitudinal section of same.

Figure 4, a longitudinal elevation of latch-bolt.

Figure 5, a transverse section of knob, knob-washer, and stop-socket, with hub or follower, and its pins.

Figure 6, a rear elevation of knob-washer.

Figure 7, an end elevation of the hub or follower.

Figure 8, a horizontal section of door, with elevation of latch-socket, &c.

Figure 9, a front elevation of knob-washer.

To enable others skilled in the art to make and use my invention, I will proceed to describe its construction and operation.

I construct my latch-case of a hollow cylinder of brass or other metal, having at right angles on one end a metallic face-plate, (as shown at D, fig. 1,) for screwing it to the edge of the door, said plate being perforated, at its joining with the case, to the size of the interior of said case. This case is also shown in elevation at T, fig. 2.

The latch-bolt H is also made of a hollow metal cylinder, the exterior diameter fitting easily the interior of the afore-mentioned case.

A solid plug is fitted into the end F, fig. 4, extending to the dotted line at v.

The interior of the latch-bolt contains a spiral working spring, shown through a removed section at z.

The screw s, fig. 2, passes entirely through from side to side of the case T; also, through the slot t of the latch-bolt, shown at fig. 4. This screw serves as the base for the spiral spring z to act against in throwing out the bolt H, and, also, by its action in the slot t, fig. 4, prevents the bolt H from being thrown too far.

g g are two opposite springs, firmly attached at n n to the bolt H. On the opposite end of these springs are attached two hooks, as shown at p p, fig. 4.

These hooks engage with the pins b b of the hub or follower C, and serve to draw the latch-bolt back

by the hub being turned in either direction by the knob-spindle B.

The hub or follower C is a flat disk of metal, attached to a cylindrical socket, o, (or it may be all made of one piece,) which fits easily the interior of the socket u, attached to the knob-washer. Attached to the cylinder o of the hub C is a pin, d, which moves in a cut-away portion of socket u of the knob-washer G, shown at l, figs. 5 and 6, which prevents said hub from being turned too far by the knob-spindle, and deranging the latch.

In applying this latch to a door, a hole is bored at right angles through the door, at the place where it is desirable to have the knob, and at such distance from the edge that the center of said hole shall correspond with the center of the axis of the knobs.

Another hole is bored in the edge of the door, and at right angles to said edge, and the axis of the two holes shall intersect each other at right angles. The first-mentioned hole should be something larger than the hub C; the size of the last-mentioned hole to be the same as the case T.

A shallow mortise should be made in the edge of the door, to let the face-plate D into, so that the surfaces shall correspond.

Put the latch, as shown at fig. 2, into the last-mentioned hole, and secure the face-plate D with screws, u u, into the shallow mortise before mentioned. On now looking through the first-mentioned hole, the hooks p p, fig. 2, will be seen. Then unite the knob-washer G with the hub, the pin d going into recesses l, putting the hub and socket u, of the washer G, into the hole. The pins b b will readily engage themselves with the hooks p p. Secure the knob-washer to the door by screws through the holes a a a. Apply the knob-washer, fig. 9, to the opposite side, as shown at G², insert the square spindle, and knobs used in the ordinary door-latch, and the latch is ready for use.

I claim—

1. The hub or follower C, with its pins b b, in combination with the latch-bolt H, having springs with hooks p p, washer G, and socket u, substantially as and for the purpose herein set forth.

2. The hub or follower C, with its pins b b and d, socket u, with its cut-away portion l, in combination with the latch-bolt H, having spring hooks p p, or springs with hooks, substantially as and for the purpose herein set forth.

JOHN THEOPHILUS WILLIAMS.

Witnesses:

W. J. JACOBS,
JAMES COOPER.