

(19) **DANMARK**

(10) **DK/EP 3820793 T3**



(12) **Oversættelse af
europæisk patentskrift**

Patent- og
Varemærkestyrelsen

-
- (51) Int.Cl.: **B 65 G 15/30 (2006.01)** **B 65 G 17/00 (2006.01)** **B 65 G 17/08 (2006.01)**
B 65 G 47/84 (2006.01) **B 65 G 47/96 (2006.01)**
- (45) Oversættelsen bekendtgjort den: **2024-06-10**
- (80) Dato for Den Europæiske Patentmyndigheds bekendtgørelse om meddelelse af patentet: **2024-05-22**
- (86) Europæisk ansøgning nr.: **19834339.4**
- (86) Europæisk indleveringsdag: **2019-06-12**
- (87) Den europæiske ansøgnings publiceringsdag: **2021-05-19**
- (86) International ansøgning nr.: **US2019036659**
- (87) Internationalt publikationsnr.: **WO2020013942**
- (30) Prioritet: **2018-07-11 US 201816032920**
- (84) Designerede stater: **AL AT BE BG CH CY CZ DE DK EE ES FI FR GB GR HR HU IE IS IT LI LT LU LV MC MK MT NL NO PL PT RO RS SE SI SK SM TR**
- (73) Patenthaver: **Laitram, L.L.C., Legal Department , 200 Laitram Lane, Harahan, LA 70123, USA**
- (72) Opfinder: **VULPETTI, Matthew, 5026 Alphonse Drive, Metairie, Louisiana 70006, USA**
- (74) Fuldmægtig i Danmark: **AWA Denmark A/S, Strandgade 56, 1401 København K, Danmark**
- (54) Benævnelse: **TRANSPORTBÅND-PLATFORMSOMLEDER**
- (56) Fremdragne publikationer:
EP-A1- 0 374 747
WO-A1-98/31614
WO-A1-2016/014196
JP-A- 2000 118 689
JP-A- 2004 026 490
US-A- 4 993 535
US-A1- 2014 332 342

DESCRIPTION

Description

BACKGROUND

[0001] The invention relates generally to power-driven conveyors and in particular to article-diverting belt conveyors.

[0002] Diverting conveyors, such as shoe sorters, are used to divert articles across the width of a conveyor as the conveyor transports the articles in a conveying direction. Typical shoe sorters include article-pushing elements called shoes that are driven laterally across the conveyor to push articles off one or both sides of the conveyor to one or more discharges. Slat conveyors and modular conveyor belts are used as platforms for the shoes, which ride in tracks extending across the widths of the slats or belt modules. The shoes are conventionally block-shaped with depending structural elements that keep the shoes in the tracks and serve as cam followers that extend below to be guided by carryway guides that control the lateral positions of the shoes. In applications where the friction between the bottoms of heavy conveyed articles and the top surface of the conveyor is high, pusher-type shoes can damage the contact sides of the articles or cause their bottoms to be marred. Or if the shoe's track does not extend close enough to a side of the conveyor belt, small articles meant to be sorted off the side can be stranded.

[0003] US 2014/332342 A1, which comprises the features mentioned in the preamble of claim 1, discloses a cleanable shoe-type diverter belt having narrow translatable pushers forming article-diverting shoes.

SUMMARY

[0004] One version of a conveyor belt embodying features of the invention, as defined in claim 1, comprises a top surface and an opposite bottom surface and a first side and an opposite second side defining the belt's width. An elongated slot extends across a portion of the width of the belt and has a top opening at the top surface and a bottom opening at the bottom surface. The top opening is wider than the bottom opening to form a ledge recessed inward of the top surface. A carrier includes a platform seatable on the ledge, a first cam follower below the bottom surface, and a neck extending through the elongated slot to connect to the platform and to the first cam follower. The neck is long enough to allow the carrier to move between a raised position in which the platform protrudes above the top surface and a lowered position in

which the platform does not protrude above the top surface.

[0005] One version of a conveyor, as defined in dependent claim 9, embodying features of the invention comprises a conveyor belt according to claim 1 and guides supported by a conveyor frame beneath an upper run of the conveyor belt. Further embodiments of the invention are defined in the remaining dependent claims.

BRIEF DESCRIPTION OF THE DRAWINGS

[0006]

FIG. 1 is an isometric view of a portion of a modular conveyor belt embodying features of the invention.

FIG. 2 is a top plan view of the conveyor belt of FIG. 1 and a guide below.

FIG. 3 is a side elevation view of the conveyor belt and guide of FIG. 2.

FIG. 4 is an isometric view of a carrier for a conveyor belt as in FIG. 1.

FIG. 5 is a top plan view of a portion of a conveyor carryway guide supporting a portion of a conveyor belt having two sets of carriers as in FIG. 4 in each belt row.

FIG. 6 is a trio of side elevation views depicting the transfer of a tray step by step onto raised carriers in a conveyor as in FIG. 5.

FIG. 7 is a trio of side elevation views depicting the transfer of a tray step by step off raised carriers in a conveyor as in FIG. 5.

FIG. 8 is a pair of front elevation views depicting a ramp movable between a lowered position out of contact with a carrier's cam follower in a conveyor as in FIG. 5 and a raised position in contact with the cam follower.

FIG. 9 is an isometric view of another version of a carrier usable in a conveyor belt as in FIG. 1 and having a lever.

FIG. 10 is an isometric view of a conveyor and a portion of a conveyor belt with a carrier as in FIG. 9 and carryway guides to divert the carrier.

FIG. 11 is an isometric view from the opposite side as the view in FIG. 10 showing an actuator for the lever of FIG. 9.

FIGS. 12A and 12B are front elevation and isometric views of a conveyor as in FIG. 11 with the levers not actuated.

FIGS. 13A and 13B are front elevation and isometric views as in FIGS. 12A and 12B with the levers actuated.

DETAILED DESCRIPTION

[0007] A portion of a conveyor belt embodying features of the invention is shown in FIGS. 1 and 2. The conveyor belt 20 is constructed of a series of rows 22 of belt modules 24 linked together at hinge joints 26 by hinge rods 28 extending through lateral passageways 30 formed by interleaved hinge elements 32 along the ends of each module. The conveyor belt 20 extends in width from a first side 34 to an opposite second side 35 and in thickness from a top surface 36 to a bottom surface 37. Elongated slots 38 extend through the thickness of the belt modules 24 across their width. In this example the slots 38 extend across only a portion of the entire width of the module 24. The conveyor belt 20 in this example has a slot 38 in each belt row 22, but a belt could be built of a mixture of rows with slots and rows without slots. The slots 38 have top and bottom openings 40, 41. The top opening 40, which opens onto the top surface 36 of the conveyor belt 20, is wider than the bottom opening 40, which opens onto the bottom surface 37. In that way a ledge 42 recessed inward of the top surface 36 is formed. A carrier 44 rides across the width of the conveyor belt on the ledge 42 in the slot 38.

[0008] As shown in FIG. 3, the carrier 44 has a depending cam follower 46 below the bottom surface 37 of the conveyor belt 20. The carrier 44 has a top platform 47 at the top surface 36 of the conveyor belt 20. A narrow neck 48 extending through the opening 38 connects at one end to the platform 47 and at the other end to the cam follower 46. A guide 50 supported beneath an upper run of the conveyor belt 20 in a conveyor frame has a vertical guide surface 52 that extends across the width of the conveyor. The vertical guide surface 52 serves as a cam surface along which the cam follower 46 rides as the motor-driven conveyor belt advances in a direction of belt travel 54. A ramp 56 transverse to the vertical guide surface 52 also serves as a cam surface against the bottom of the cam follower 46 to raise the carrier 44 to a position in which the platform 47 protrudes above the top surface 36 of the belt 20. The ramp 56 rises from a lower end 59 to a higher end 63 at a horizontal cam surface 57 that maintains the carrier in the raised position.

[0009] One version of a carrier 44 is shown in FIG. 4. The top platform 47 has a flat top face 58 and rounded ends 60, 61. The neck 48 connects at one end to the platform 47 and at the other end to the cam follower 46. The neck 48 is narrow enough to fit in the slot in the conveyor belt 20 and long enough to provide the carrier 44 with a vertical range of motion from a raised position in which the platform 47 protrudes above the top surface 36 of the belt, as on the right side of FIG. 3, to a lowered position in which the platform sits on the ledge, i.e., flush with or recessed below the top surface 36 without protruding. The cam follower 46 has a curved outer vertical face 62 that rides along the vertical guide surface 52 and a curved bottom face 64 that rides on the ramp 56 and the horizontal cam surface 57.

[0010] FIG. 5 shows a conveyor 75 with a portion of a conveyor belt 66 having two slots 38 -

one on each half of the belt - in each belt row 22. The carriers 44 received in the slots 38 are elongated along the width of the belt 66. A conveyor frame 68 supports the belt 66 and upstream and downstream guides 70R, 70L, 71R, 71L in an upper carryway run. The two upstream guides 70R, 70L have vertical guide surfaces 72 arranged obliquely across the width of the conveyor 75 to guide the carriers 44 toward the widthwise middle of the belt as the belt 20 advances in the direction of belt travel 54. The ramp 56 at the upstream ends of the upstream guides 70L, 70R raises the carriers 44 to the raised position as their cam followers ride up the ramp. The horizontal cam surface 57 extending horizontally from the top of the ramp 56 maintains the carriers in the raised position as they advance downstream. An article, such as a tray 74, sitting atop the carriers 44 is translated across the top surface 36 of the belt 66 by the raised carriers. All the carriers 44, upon passing the downstream ends 76 of the upstream guides 70L, 70R, are positioned at the inner ends 78 of the slots 38. When the carriers 44 reach the ends 80 of horizontal cam surfaces 57, they drop to the lowered position. The cam followers of the lowered carriers 44 then encounter the downstream guides 71L, 71R, which translate the lowered carriers back to starting positions proximate to the outer sides 82, 83 of the conveyor 75. Thus, the downstream guides 71L, 71R with vertical surfaces 73, but without ramps and horizontal cam surfaces, keep the carriers lowered and align their cam followers laterally with the positions of the ramps 56 on the upstream guides 70L, 70R for proper engagement of the cam followers with the ramps in the next belt cycle.

[0011] FIG. 6 illustrates cam followers 46 of carriers 44 engaging a guide 50 as the belt 20 advances in the direction of belt travel 54 to move a tray 74 across the width of the belt (out of the page in FIG. 6). In the top view the tray 74 sits directly on the top surface 36 of the belt 20 because the carriers 44 are lowered with their platforms flush with or recessed below the top surface. As the cam followers 46 on the carriers 44 supporting the leading end of the tray 74 ride up the ramp 56, they lift the front end of the tray 74 above the top surface 36 of the belt as in the middle view of FIG. 6. And as the cam followers 46 on the leading carriers 46 engage the vertical guide surface 52, the carriers start diverting the leading end of the tray 74 in the direction of the vertical guide surface (out of the page in FIG. 6). Once the trailing cam followers 46 of the carriers 44 supporting the tray 74 encounter the ramp 56 as in the bottom view of FIG. 6, the entire tray is supported above the top surface 36 on the raised carriers. The vertical guide surfaces 52 acting on the sides of the trailing cam followers 46 urge the trailing end of the tray laterally toward alignment with the leading end in the direction of belt travel 54.

[0012] FIG. 7 shows the gentle release of a diverted tray 74 from atop raised carriers 44 riding on a horizontal cam surface 57. In the top view the carriers 44 supporting the tray 74 are all raised above the belt's top surface 36. In the middle view the carriers 44 supporting the trailing end of the tray 74 are raised. The leading end of the tray 74 is supported on the top surface 36 of the belt 20 because the carriers 44 under the leading end are in their lowered position after riding down the ramp 56. In the bottom view all the carriers 44 under the tray 74 are lowered, and the tray sits directly on the top surface 36 of the belt 20 to be conveyed in the direction of belt travel 54.

[0013] FIG. 8 shows a retractable ramp 56 and horizontal guide surface 57 selectively raised

and lowered by actuators 76, such as linear actuators. In the upper view the ramp 56 and horizontal cam surface 57 are shown in a lowered, or retracted, position below the lowest level 78 of the carriers' cam followers 46. In the retracted position of the ramp 65 and the horizontal cam surface 57, the carriers 44 are maintained in their lowered positions out of contact with conveyed articles. In the lower view the actuators 76 are shown lifting the ramp 56 and horizontal cam surface 57 to the extended position providing a cam surface on which the cam followers 46 can ride to raise the carriers 44 to the raised position.

[0014] Another version of a carrier is shown in FIG. 9. Like the carrier 44 of FIG. 4, the carrier 80 has a cam follower 82, a top platform 84, and a narrow connecting neck 86. And it also has a lever 88 pivotally connected to the platform 84. The lever 88 has a second cam follower 90 extending downward like a keel from a flipper plate 92. The flipper plate 92 extends from a pivot shank 94 at one end. The shank 94 has a pivot formed by an eyelet that receives a pivot pin 96 whose ends are retained in the platform 84. As one alternative, the pivot can be realized by trunnions extending from the sides of the pivot shank 94 to holes in the platform 84. When retracted, the lever is received in an opening 98 through the platform 84, and the top surface of the flipper plate 92 is flush with the top surface of the platform 84. The main cam follower 82 of the carrier 80 is offset from the second cam follower 90 in directions both parallel and perpendicular to the direction of the lever's pivot axis 100 so that the two cam followers can be actuated independently. In this example the pivot is situated close to an end of the platform 84.

[0015] As shown in FIGS. 10 and 11, the carriers 80 ride in elongated slots 38 in a conveyor belt 102. The vertical guide surface 52 of the guide 50 pushes the carriers 80 across the width of the belt 102 as it advances in the direction of belt travel 54. The ramp 56 and the horizontal cam surface 57 raise the carriers 80 above the belt's top surface 36 to support and carry conveyed articles when the actuator 76 is energized to lift the ramp and the horizontal guide surface into contact with the bottom of the carriers' cam followers. When deactuated by the actuator 76, the ramp 56 and the horizontal guide surface 57 are lowered out of contact with the carriers' cam followers. As shown in FIG. 11, a cam surface 104 elongated in the direction of belt travel 54 is positioned downstream of the exit from the guide 50. The guide 50 aligns the cam follower of the lever 88 laterally across the width of the conveyor with the cam surface 104. An actuator 106 supported in the conveyor frame 108 selectively moves the cam surface 104 into or out of contact with the levers' cam followers.

[0016] FIGS. 12A and 12B show the effect of retracted levers on a tray 74 supported on the top surface 36 of the belt 102 when the carriers 80 are also lowered. The piston 110 of the lever's actuator 106 is retracted to put the levers in the retracted position allowing the tray to continue to translate laterally to a position near a side of the belt 102. In FIGS. 13A and 13B the actuator 106 is shown with its piston 110 extended pushing the cam surface 104 up toward the bottom 112 of the belt 102 and against the cam followers 90 of the levers 88. Engagement of the cam followers 90 with the cam surface 104 pivots the levers 88 so that their flipper plates assume an angle 114 with the top surface 36 of the belt 102. In the extended position, the levers 88 flip the tray 74 off the near side of the belt.

[0017] Embodiments other than those disclosed in detail are possible. For example, the cam followers can slide along the cam surfaces as shown or can be roller cams with rollers at their ends to roll rather than slide on the cam surfaces. As another example, the lever actuator can be positioned away from the sides of the conveyor to flip articles on the conveyor belt. For example, it may be desirable to flip a box to expose a side with indicia to a scanner.

REFERENCES CITED IN THE DESCRIPTION

Cited references

This list of references cited by the applicant is for the reader's convenience only. It does not form part of the European patent document. Even though great care has been taken in compiling the references, errors or omissions cannot be excluded and the EPO disclaims all liability in this regard.

Patent documents cited in the description

- [US2014332342A1 \[0003\]](#)

PATENTKRAV

1. Transportbånd (20; 66; 102), der omfatter:
 - en overflade (36) og en modstående bundflade (37) og en første side (34) og en
 - 5 modstående anden side (35), der definerer transportbåndets bredde;
 - en aflange spalte (38), der strækker sig på tværs af en del af båndets (20) bredde og har en øvre åbning (40) ved overfladen (36) og en bundåbning (41) ved bundfladen (37);
 - en bærer (44; 80), der indbefatter:
 - en platform (47; 84);
 - 10 en første knastfølger (46; 82) under bundfladen (37);
 - en hals (48; 86), der strækker sig gennem den aflange spalte (38) til at forbinde til platformen (47; 84) og til den første knastfølger (46; 82);
 - hvor halsen (48; 86) er tilstrækkeligt lang til at gøre det muligt for bæreren (44; 80) at bevæge sig mellem en hævet position, hvori platformen (47; 84) rager op over overfladen
 - 15 (36), og en sænket position, hvori platformen (47; 84) ikke rager op over overfladen (36), kendetegnet ved, at den øvre åbning (40) er bredere end bundåbningen (41) for at danne en afsats (42) forsænket i overfladen (36), og ved at platformen (47, 84) kan anbringes på afsatsen (42).
- 20 2. Transportbånd (20) ifølge krav 1, hvor a) platformen (47) modtages på afsatsen (42), når bæreren (44) er i den sænkede position; eller b) platformen (47) har en flad top flugtende med transportbåndets (20) overflade (36), når bæreren (44) er i den sænkede position; eller c) platformen (47) er aflange langs den aflange spalte (38).
- 25 3. Transportbånd (20) ifølge krav 1, og som omfatter en række af rækker (22) af bæltmoduler (24) hængslende forbundet med hinanden ved hængselssamlinger (26) mellem tilstødende rækker (22), hvor en flerhed af rækkerne (22) indbefatter de aflange spalter (38) dannet mellem hængselssamlingerne (26) og bærerne (44) modtaget i de aflange spalter (38).
- 30 4. Transportbånd (66) ifølge krav 3, hvor hver af flerheden af rækker (22), der indbefatter bærere (44), har to aflange spalter (38) anbragt adskilt på tværs af transportbåndets (66) bredde og en bærer (44) i hver af de aflange spalter (38).
- 35 5. Transportbånd (102) ifølge krav 1, hvor bæreren (80) indbefatter en vægtstang (88), der kan dreje mellem en tilbageført position forsænket i platformen (84) og en fremført

position, der rager op fra platformen (84) i en vinkel i forhold til overfladen af transportbåndet.

- 5 6. Transportbånd (102) ifølge krav 5, hvor vægtstangen (88) har en drejetap, der er drejeligt forbundet med bæreren (80) ved en ende af platformen (84).
7. Transportbånd (102) ifølge krav 5, hvor vægtstangen (88) har en anden knastfølger (90), der strækker sig under bundfladen af transportbåndet (102) og forskudt for den første knastfølger (82) i en længderetning for transportbåndet (102).
- 10 8. Transportbånd (102) ifølge krav 5, hvor platformen (84) har en åbning (98), der er dimensioneret til at modtage vægtstangen (88) i den tilbageførte position flugtende med overfladen af transportbåndet (102), når bæreren (80) er i den sænkede position.
- 15 9. Transportør (75), der omfatter:
et transportbånd (66) ifølge et hvilket som helst af kravene 1 til 4, og som endvidere indbefatter:
en flerhed af de aflange spalter (38), der strækker sig på tværs af transportbåndets (66) bredde på adskilte steder langs transportbåndets (66) bredde i en
20 båndbevægelsesretning (54);
hvor bæreren (44) modtaget i hver af de aflange spalter (38) kan føres tilbage;
en transportørramme (68);
føringer (70R, 70L, 71R, 71L) understøttet af transportørrammen (68) under et nedre løb af transportbåndet (66), hvor føringerne (70R, 70L, 71R, 71L) indbefatter:
25 en vertikal føringsflade (72), der strækker sig skråt på tværs af det øvre løb for at komme i kontakt med de første knastfølgere (46), når transportbåndet (66) fremføres opstrøms til nedstrøms i båndbevægelsesretningen (54) for at bevæge bærerne (44) langs deres spalter (38);
en rampe (56) på tværs af den vertikale føringsflade (72) ved en ende af hver af
30 føringerne (70R, 70L, 71R, 71L), opad hvilken de første knastfølgere (46) kører, når de bevæges langs deres spalter (38) for at hæve platformene (47) til en hævet position, hvori platformene (47) rager op over overfladen af transportbåndet (66).
10. Transportør (75) ifølge krav 9, hvor føringerne (70R, 70L, 71R, 71L) indbefatter en
35 anden rampe (56) ved en modsat ende, nedad hvilken knastfølgere (46) kører, når de bevæges langs deres spalter (38) for at sænke platformene (47) til en sænket position, hvori platformene (47) føres tilbage ind i de aflange spalter (38).

11. Transportør (75) ifølge krav 9, hvor ramperne (56) er nær den første eller anden side af transportbåndet (66).
- 5 12. Transportør (75) ifølge krav 9, og som omfatter én eller flere aktuatorer (76) koblet til ramperne (56) til at bevæge ramperne (56) fra en første position for at modtage knastfølgerne (46) til en anden position under knastfølgerens (46) niveau.
- 10 13. Transportør ifølge krav 9, hvor bæreren (80) indbefatter en vægtstang (88), der kan dreje mellem en tilbageført position forsænket i platformen (84) og en fremført position, der rager op fra platformen (84) i en vinkel i forhold til overfladen af transportbåndet (66).
- 15 14. Transportør ifølge krav 13, hvor vægtstangen (88) har en anden knastfølger (90), der strækker sig under bundfladen af transportbåndet (66), og hvor transportøren omfatter:
en knastflade (104), der er aflang i bæltets bevægelsesretning (54) og understøttet af transportørrammen i en position over transportbåndets bredde på linje med den anden knastfølger (90), når bæreren (80) er ved en ende af den aflange spalte (38); og
en aktuator (106), der selektivt bevæger knastfladen ind i eller ud af kontakt med den anden knastfølger (90) for at dreje vægtstangen (88) mellem den fremførte og
20 tilbageførte position.
- 25 15. Transportør ifølge krav 14, hvor enden af den aflange spalte (38) er tilstrækkeligt tæt på den første eller anden side af transportbåndet (102), således at drejning af vægtstangen (88) fra den tilbageførte position til den fremførte position vipper genstande båret på overfladen af transportbåndet (102) over bæreren (80) ved enden af den aflange spalte (38) af til den første eller anden side af transportbåndet (102).

DRAWINGS

Drawing

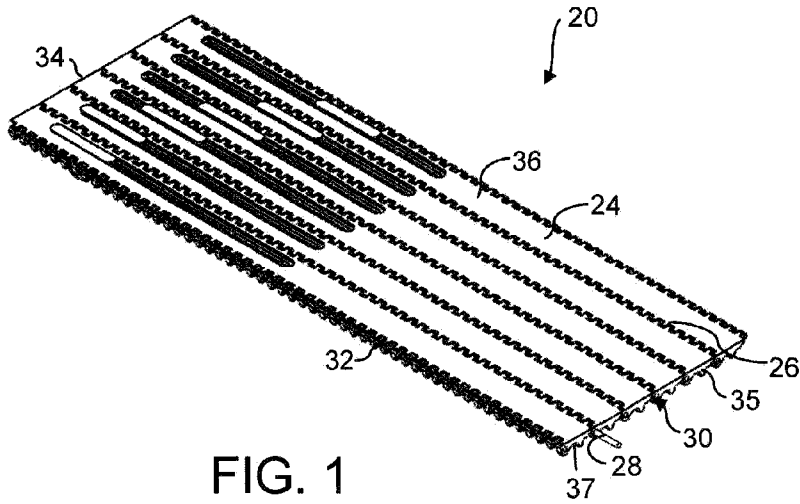

FIG. 1

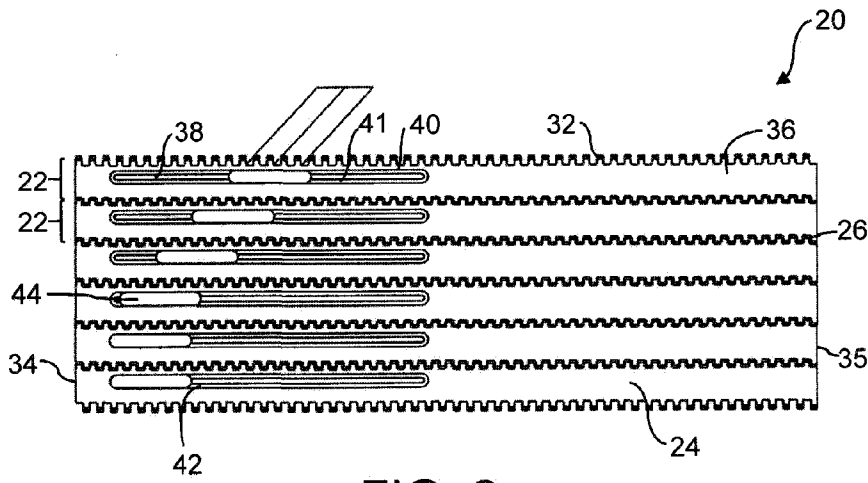

FIG. 2

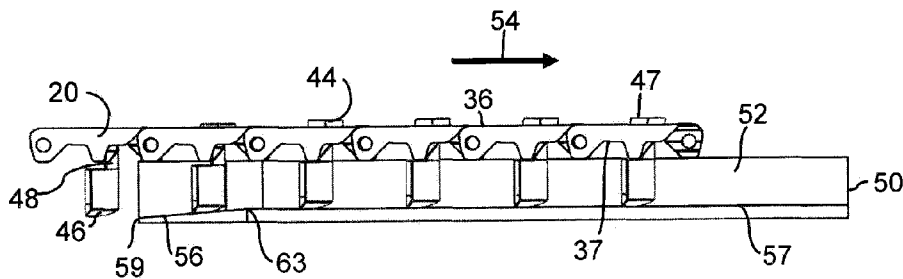

FIG. 3

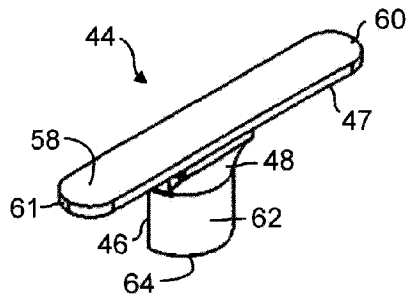

FIG. 4

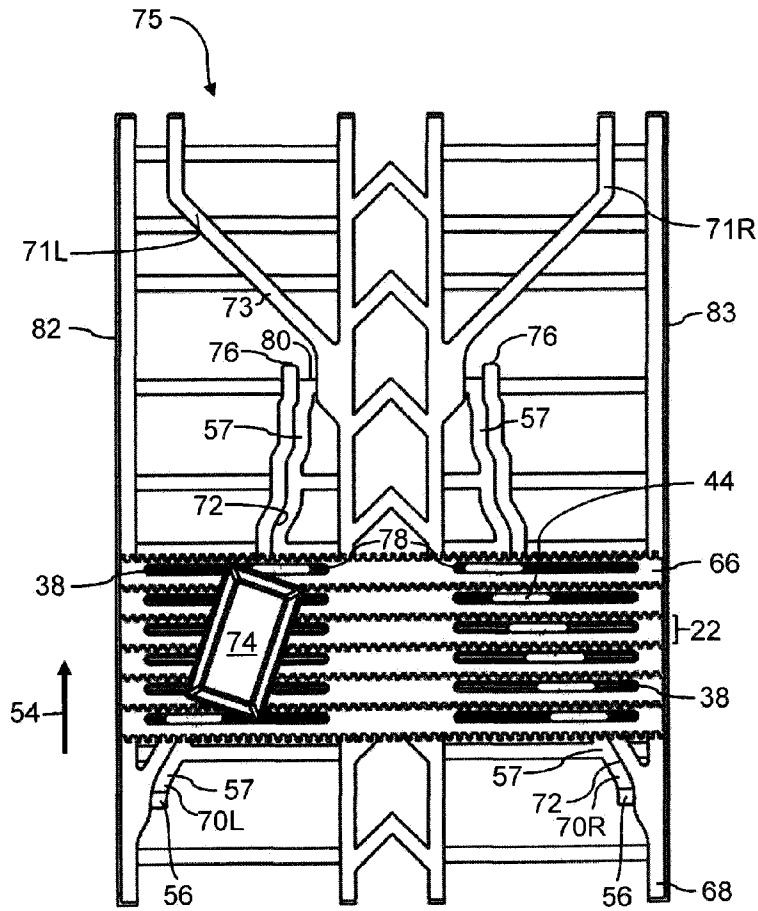

FIG. 5

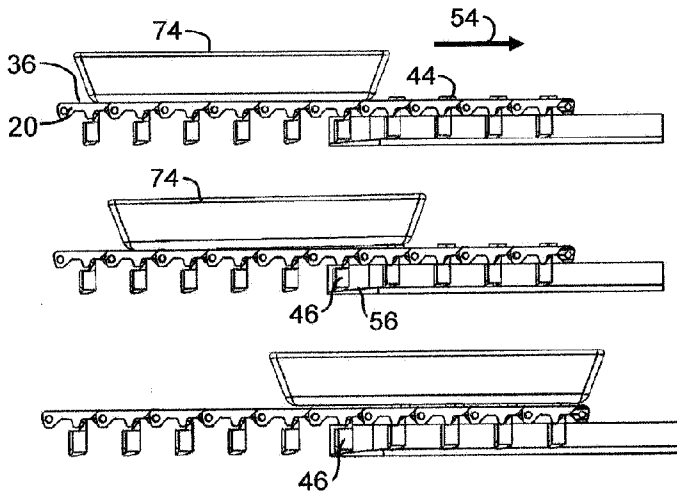

FIG. 6

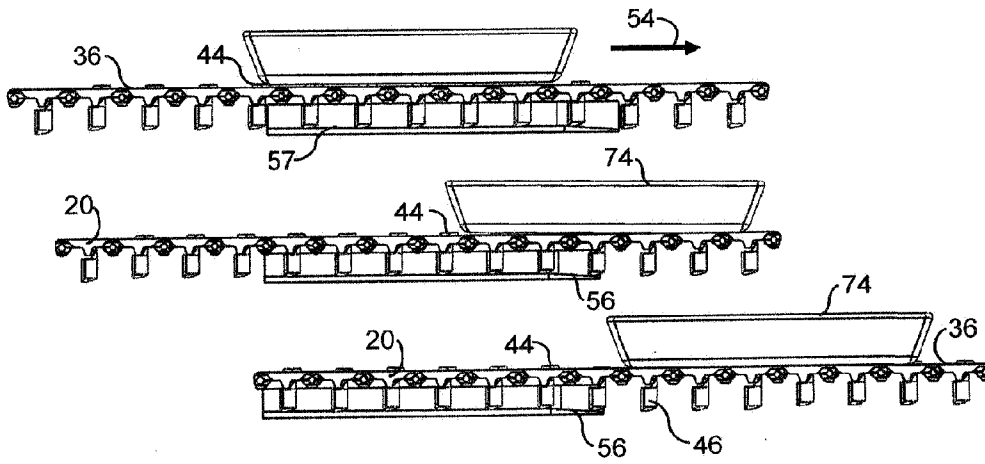

FIG. 7

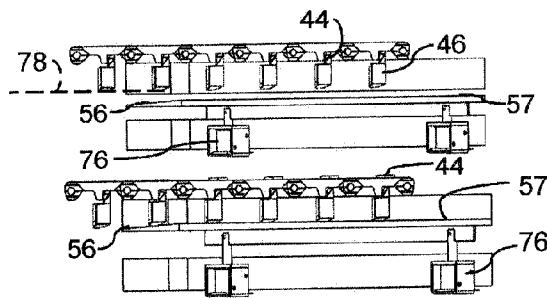

FIG. 8

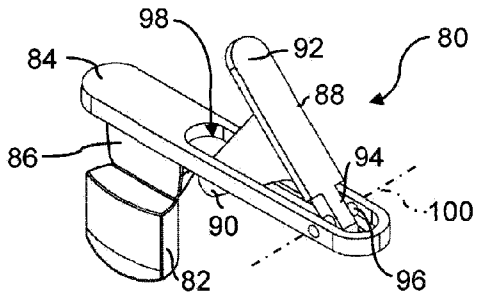

FIG. 9

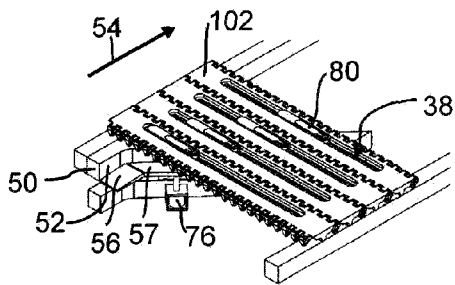

FIG. 10

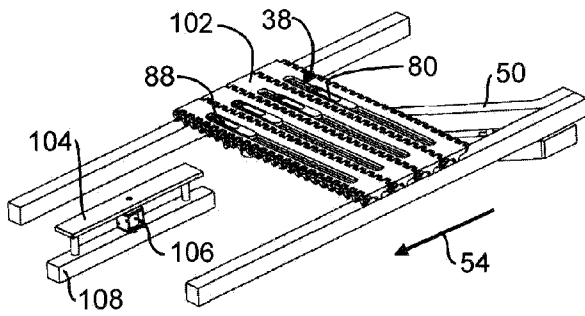

FIG. 11

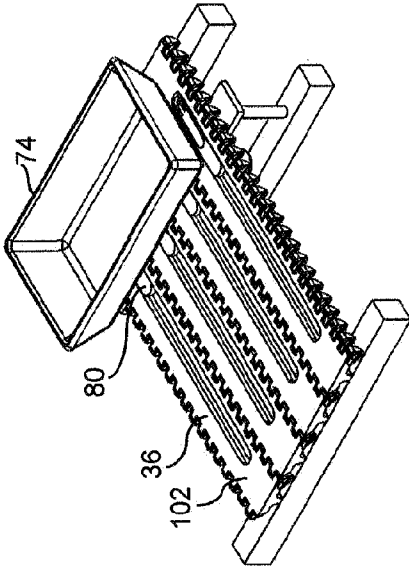

FIG. 12B

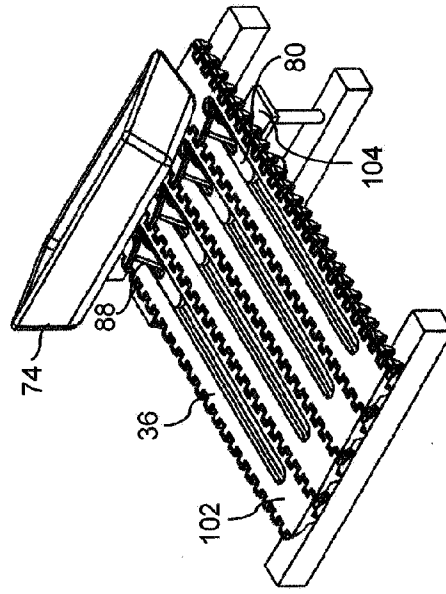

FIG. 13B

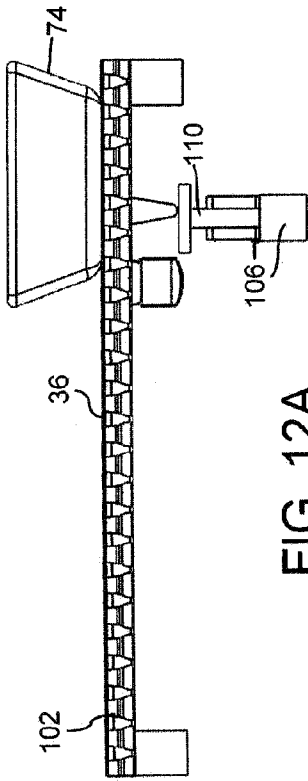

FIG. 12A

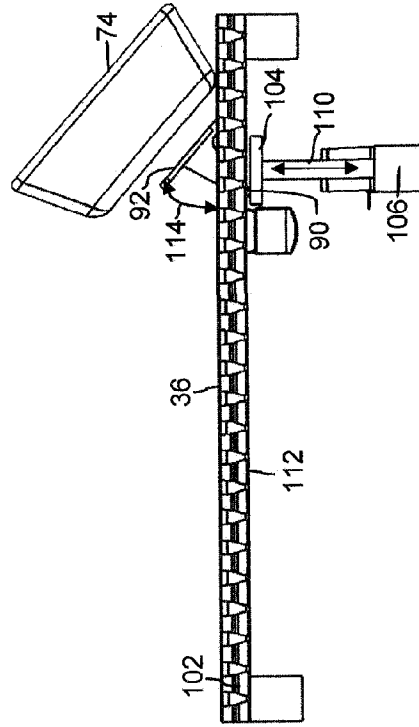

FIG. 13A