



US 20220030935A1

(19) **United States**

(12) **Patent Application Publication**  
**UTHURRY**

(10) **Pub. No.: US 2022/0030935 A1**

(43) **Pub. Date: Feb. 3, 2022**

(54) **AEROSOL GENERATING ARTICLE WITH LIGHT HOLLOW SEGMENT**

**Publication Classification**

(71) Applicant: **Philip Morris Products S.A.**,  
Neuchatel (CH)

(51) **Int. Cl.**  
*A24D 1/20* (2006.01)  
*A24D 1/02* (2006.01)  
*A24D 1/04* (2006.01)

(72) Inventor: **Jerome UTHURRY**, Neuchatel (CH)

(52) **U.S. Cl.**  
CPC ..... *A24D 1/20* (2020.01); *A24D 1/042*  
(2013.01); *A24D 1/027* (2013.01)

(73) Assignee: **Philip Morris Products S.A.**,  
Neuchatel (CH)

(57) **ABSTRACT**

(21) Appl. No.: **17/414,067**

An aerosol-generating article for producing an inhalable aerosol upon heating is provided, the article including: a rod of aerosol-generating substrate; a hollow tubular segment at a location downstream of the rod, being in longitudinal alignment with the rod, and defining a cavity extending from an upstream end to a downstream end of the hollow tubular segment; a mouthpiece segment downstream of the hollow tubular segment and including a plug of filtration material and a mouth end recess downstream of the plug; and a ventilation zone along the hollow tubular segment less than 20 millimetres from a downstream end of the article and including one or more rows of perforations formed through a peripheral wall of the hollow tubular segment, and the rod including at least an aerosol former and having an aerosol former content of at least about 12 percent on a dry weight basis.

(22) PCT Filed: **Dec. 20, 2019**

(86) PCT No.: **PCT/EP2019/086807**

§ 371 (c)(1),  
(2) Date: **Jun. 15, 2021**

(30) **Foreign Application Priority Data**

Dec. 20, 2018 (EP) ..... 18214844.5

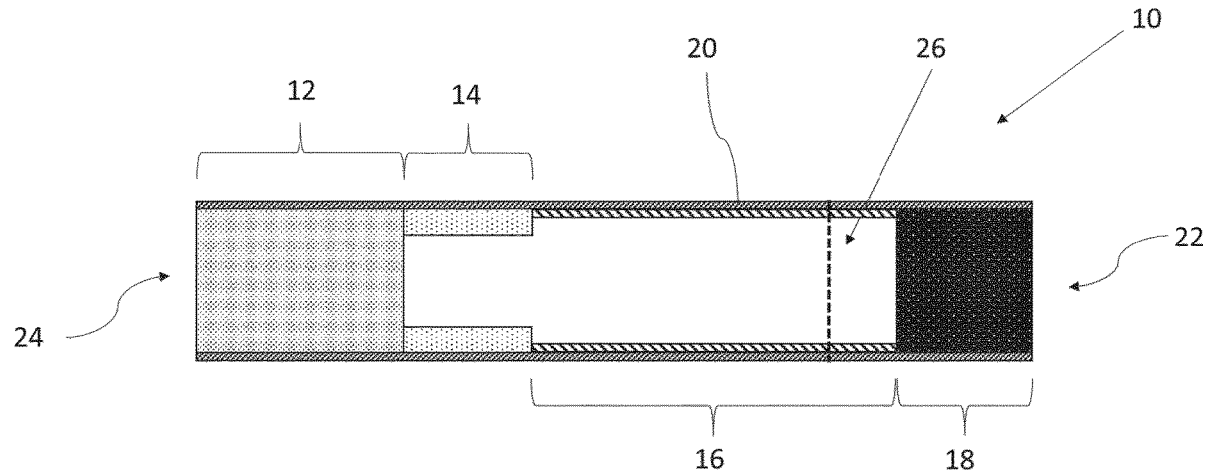

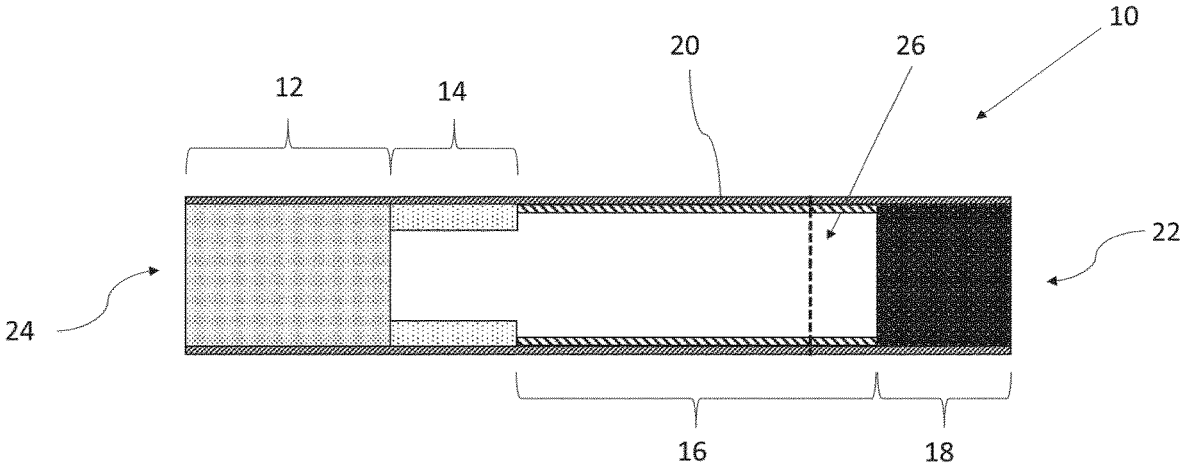

Figure 1

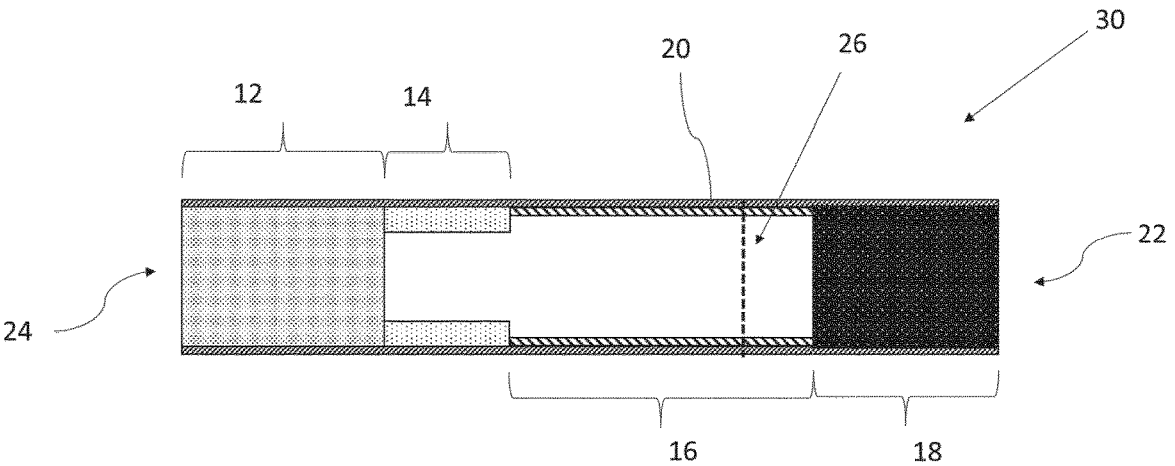

Figure 2



Figure 3

### AEROSOL GENERATING ARTICLE WITH LIGHT HOLLOW SEGMENT

**[0001]** The present invention relates to an aerosol generating article comprising an aerosol-generating substrate and adapted to produce an inhalable aerosol upon heating.

**[0002]** Aerosol-generating articles in which an aerosol-generating substrate, such as a tobacco-containing substrate, is heated rather than combusted, are known in the art. Typically in such heated smoking articles, an aerosol is generated by the transfer of heat from a heat source to a physically separate aerosol-generating substrate or material, which may be located in contact with, within, around, or downstream of the heat source. During use of the aerosol-generating article, volatile compounds are released from the aerosol-generating substrate by heat transfer from the heat source and are entrained in air drawn through the aerosol-generating article. As the released compounds cool, they condense to form an aerosol.

**[0003]** A number of prior art documents disclose aerosol-generating devices for consuming aerosol-generating articles. Such devices include, for example, electrically heated aerosol-generating devices in which an aerosol is generated by the transfer of heat from one or more electrical heater elements of the aerosol-generating device to the aerosol-generating substrate of a heated aerosol-generating article.

**[0004]** Substrates for heated aerosol-generating articles have, in the past, typically been produced using randomly oriented shreds, strands, or strips of tobacco material. As an alternative, rods for heated aerosol-generating articles have been proposed, for example in international patent application WO-A-2012/164009, that are formed from gathered sheets of tobacco material. The rods disclosed in WO-A-2012/164009 have a longitudinal porosity that allows air to be drawn through the rods. Effectively, folds in the gathered sheets of tobacco material define longitudinal channels through the rod.

**[0005]** Alternative rods for heated aerosol-generating articles are known from international patent application WO-A-2011/101164. These rods are formed from strands of homogenised tobacco material, which may be formed by casting, rolling, calendering or extruding a mixture comprising particulate tobacco and at least one aerosol former to form a sheet of homogenised tobacco material. In an alternative embodiments, the rods of WO-A-2011/101164 may also be formed from strands of homogenised tobacco material obtained by extruding a mixture comprising particulate tobacco and at least one aerosol former to form continuous lengths of homogenised tobacco material.

**[0006]** Substrates for heated aerosol-generating articles typically further comprise an aerosol former, that is, a compound or mixture of compounds that, in use, facilitates formation of the aerosol and that preferably is substantially resistant to thermal degradation at the operating temperature of the aerosol-generating article. Examples of suitable aerosol-formers include: polyhydric alcohols, such as propylene glycol, triethylene glycol, 1,3-butanediol and glycerin; esters of polyhydric alcohols, such as glycerol mono-, di- or triacetate; and aliphatic esters of mono-, di- or polycarboxylic acids, such as dimethyl dodecanedioate and dimethyl tetradecanedioate.

**[0007]** It is also common to include in an aerosol-generating article for producing an inhalable aerosol upon heating one or more additional elements that are assembled with the

substrate in a same wrapper. Examples of such additional elements include a mouthpiece filtration segment, a support element adapted to impart structural strength to the aerosol-generating article, a cooling element adapted to favour cooling of the aerosol prior to reaching the mouthpiece, and so forth. However, although the inclusion of such additional elements has been proposed in view of their advantageous effects, it generally complicates the overall structure of the aerosol-generating article and makes it manufacture more complex and costly. In fact, manufacturing such multi-element aerosol-generating articles typically requires rather complex making machinery and combining machinery.

**[0008]** In view of this, aerosol-generating articles have also been proposed that have a simpler structure. However, in the absence of certain additional components, such as, for example, an-aerosol-cooling element, it may become more difficult to manufacture aerosol-generating articles that consistently provide the consumer with a satisfactory aerosol delivery and RTD.

**[0009]** Thus, it would be desirable to provide an aerosol generating article that enables the provision of a consistently satisfactory aerosol delivery to the consumer during use. Further, it would be desirable to provide one such improved aerosol-generating article that has a satisfactory RTD value. It would be equally desirable to provide one such aerosol-generating article that can be manufactured efficiently and at high speed, preferably with a low RTD variability from one article to another. The present invention aims at providing a technical solution adapted to achieve at least one of the desirable results described above.

**[0010]** According to an aspect of the present invention, there is provided an aerosol-generating article for producing an inhalable aerosol when heated, the aerosol-generating article comprising: a rod of aerosol-generating substrate; and a hollow tubular segment at a location downstream of the rod. The hollow tube segment is in longitudinal alignment with the rod and defines a cavity extending all the way from an upstream end of the hollow tubular segment to a downstream end of the hollow tubular segment. Further, the hollow tubular segment has a length of less than about 25 millimetres. The aerosol-generating article further comprises a ventilation zone at a location along the hollow tubular segment. A ratio between a weight of the hollow tubular segment and a volume of the internal cavity defined by the hollow tubular segment is less than 1 milligram/cubic millimetre. The rod of aerosol-generating substrate comprises at least an aerosol former, the rod of aerosol-generating substrate having an aerosol former content of at least about 10 percent on a dry weight basis.

**[0011]** The term “aerosol generating article” is used herein to denote an article wherein an aerosol generating substrate is heated to produce an deliver inhalable aerosol to a consumer. As used herein, the term “aerosol generating substrate” denotes a substrate capable of releasing volatile compounds upon heating to generate an aerosol.

**[0012]** A conventional cigarette is lit when a user applies a flame to one end of the cigarette and draws air through the other end. The localised heat provided by the flame and the oxygen in the air drawn through the cigarette causes the end of the cigarette to ignite, and the resulting combustion generates an inhalable smoke. By contrast, in heated aerosol generating articles, an aerosol is generated by heating a flavour generating substrate, such as tobacco. Known heated aerosol generating articles include, for example, electrically

heated aerosol generating articles and aerosol generating articles in which an aerosol is generated by the transfer of heat from a combustible fuel element or heat source to a physically separate aerosol forming material. For example, aerosol generating articles according to the invention find particular application in aerosol generating systems comprising an electrically heated aerosol generating device having an internal heater blade which is adapted to be inserted into the rod of aerosol generating substrate. Aerosol generating articles of this type are described in the prior art, for example, in EP 0822670.

**[0013]** As used herein, the term “aerosol generating device” refers to a device comprising a heater element that interacts with the aerosol generating substrate of the aerosol generating article to generate an aerosol.

**[0014]** In the present specification, the term “tubular segment” is used to denote an elongate element defining a lumen or airflow passage along a longitudinal axis thereof. In particular, the term “tubular” will be used in the following with reference to a tubular element having a substantially cylindrical cross-section and defining at least one airflow conduit establishing an uninterrupted fluid communication between an upstream end of the tubular element and a downstream end of the tubular element. However, it will be understood that alternative geometries of the cross-section of the tubular element may be possible.

**[0015]** As used herein, the term “longitudinal” refers to the direction corresponding to the main longitudinal axis of the aerosol-generating article, which extends between the upstream and downstream ends of the aerosol-generating article. As used herein, the terms “upstream” and “downstream” describe the relative positions of elements, or portions of elements, of the aerosol-generating article in relation to the direction in which the aerosol is transported through the aerosol-generating article during use.

**[0016]** During use, air is drawn through the aerosol-generating article in the longitudinal direction. The term “transverse” refers to the direction that is perpendicular to the longitudinal axis. Any reference to the “cross-section” of the aerosol-generating article or a component of the aerosol-generating article refers to the transverse cross-section unless stated otherwise.

**[0017]** The term “length” denotes the dimension of a component of the aerosol-generating article in the longitudinal direction. For example, it may be used to denote the dimension of the rod or of the elongate tubular elements in the longitudinal direction.

**[0018]** The term “thickness of a peripheral wall of the tubular element” is used in the present specification to denote the minimum distance measured between the outer surface and the inner surface of the wall delimiting peripherally the tubular element. In practice, the distance at a given location is measured along a direction locally substantially perpendicular to the outer surface and the inner surface of the tubular element. For a tubular element having a substantially circular cross-section, the distance is measured along a substantially radial direction of the tubular element.

**[0019]** In some embodiments, the thickness of the peripheral wall of the tubular element is constant. In alternative embodiments, the thickness of the peripheral wall of the tubular element varies along the length of the tubular element. This may be because the tubular element is formed from a material having an irregular surface finish (for example, the tubular element is provided in the form of a

cellulose acetate tube). Alternatively, this may be because the tubular element is designed to include a tapered section or the like. In embodiments wherein the thickness of the peripheral wall of the tubular element varies along the length of the tubular element, the “thickness of a peripheral wall of the tubular element” is taken as the average value calculated on the basis of several values measured as the minimum distance between the outer surface and the inner surface of the wall at different locations along the length of the tubular element.

**[0020]** In any embodiment, a particularly significant parameter is the thickness of the peripheral wall of the tubular element at the location of the ventilation zone.

**[0021]** The expression “air-impervious material” is used throughout this specification to mean a material not allowing the passage of fluids, particularly air and smoke, through interstices or pores in the material. If the hollow tubular segment is formed of a material impervious to air and aerosol particles, air and aerosol particles drawn through the hollow tubular segment are forced to flow through the airflow conduit internally defined by the hollow tubular segment, but cannot flow across the peripheral wall of the hollow tubular segment.

**[0022]** As used in the present specification, the term “homogenised tobacco material” encompasses any tobacco material formed by the agglomeration of particles of tobacco material. Sheets or webs of homogenised tobacco material are formed by agglomerating particulate tobacco obtained by grinding or otherwise powdering of one or both of tobacco leaf lamina and tobacco leaf stems. In addition, homogenised tobacco material may comprise a minor quantity of one or more of tobacco dust, tobacco fines, and other particulate tobacco by-products formed during the treating, handling and shipping of tobacco. The sheets of homogenised tobacco material may be produced by casting, extrusion, paper making processes or other any other suitable processes known in the art.

**[0023]** The term “porous” is used herein to refer to a material that provides a plurality of pores or openings that allow the passage of air through the material.

**[0024]** The term “ventilation level” is used throughout the present specification to denote a volume ratio between the airflow admitted into the aerosol-generating article via the ventilation zone (ventilation airflow) and the sum of the aerosol airflow and the ventilation airflow. The greater the ventilation level, the higher the dilution of the aerosol flow delivered to the consumer.

**[0025]** As briefly described above, the aerosol-generating article of the present invention comprises a rod of aerosol-generating substrate, and a hollow tubular segment at a location downstream of the rod. These two elements are longitudinally aligned. The rod of aerosol-generating substrate comprises at least an aerosol former.

**[0026]** In contrast to known aerosol-generating articles, the rod of aerosol-generating substrate has an aerosol former content of at least about 10 percent on a dry weight basis. Further, the hollow tubular segment defines a cavity that extends all the way to an upstream end of the hollow tubular segment to a downstream end of the hollow tubular segment, and has a length of less than about 25 millimetres. A ventilation zone is provided at a location along the hollow tubular segment. In addition, ratio between a weight of the

hollow tubular segment and a volume of the internal cavity defined by the hollow tubular segment is less than 1 milligram/cubic millimetre.

**[0027]** By providing an aerosol-generating article wherein a hollow tubular element is arranged between the rod of aerosol-generating substrate and the mouth end of the aerosol-generating article, wherein the hollow tubular element defines a cavity extending all the way from an upstream end of the hollow tube segment to a downstream end of the hollow tubular segment, the overall structural complexity of the article may be significantly reduced compared with existing aerosol-generating articles. This advantageously simplifies the manufacturing process and reduces the complexity of the making and combining apparatus required for implementing the manufacturing process.

**[0028]** One such aerosol-generating article does not comprise an aerosol-cooling element adapted to lower the temperature of a stream of aerosol drawn through the aerosol-generating article—as is the case, for example, with the aerosol-generating articles described in international patent application WO 2013/120565.

**[0029]** The inventors have found that a satisfactory cooling of the stream of aerosol generated upon heating the article and drawn through the hollow tubular element is achieved by providing a ventilation zone at a location along the hollow tubular segment. Further, the inventors have surprisingly found that, by utilising a hollow tubular segment having a length of less than about 25 millimetres and wherein a ratio between a weight of the hollow tubular segment and a volume of the internal cavity defined by the hollow tubular segment is less than 1 milligram/cubic millimetre, it may be possible to counter the effects of the increased aerosol dilution caused by the admission of ventilation air into the article.

**[0030]** Without wishing to be bound by theory, it is hypothesised that, because the temperature of the aerosol stream is rapidly lowered by the introduction of ventilation air as the aerosol is travelling towards the mouth end, the ventilation air being admitted into the aerosol stream at a location relatively close to the upstream end of the hollow tubular segment (that is, sufficiently close to the heat source and to the rod of aerosol-generating substrate), a dramatic cooling of the aerosol stream is achieved, which has a favourable impact on the condensation and nucleation of the aerosol particles. Accordingly, the overall proportion of the aerosol particulate phase to the aerosol gas phase may be enhanced compared with existing, non-ventilated aerosol-generating articles.

**[0031]** By providing a cavity having one such large volume as is the case with articles in accordance with the invention, a cooling chamber is effectively provided within which the condensation of aerosol particles upstream of a mouth end of the article may be favoured, as nucleation phenomena are enhanced by slowing down the flow of the aerosol stream. Without wishing to be bound by theory, it is understood that the provision a sufficiently wide tubular cavity downstream of the rod of aerosol-generating substrate favours the formation of a satisfactory amount of aerosol during use. In turn, a greater fraction of the generated aerosol particles to begin to condense prior to reaching the mouth end of the article.

**[0032]** At the same time, hollow tubular segments falling within the ranges described above provide sufficient structural strength to the article and maintain the rod of aerosol-

generating article at a predetermined distance from a mouth end of the article. Accordingly, such hollow tubular segments provide a sufficiently long chamber for the aerosol stream to flow in, and therefore enough time is made available during use for the temperature of the volatilised species to be reduced and for nucleation of aerosol particles to take place. Further, a relatively short hollow tubular segment as in aerosol-generating articles in accordance with the invention has been found to enable good aerosol nucleation whilst, at the same time, not presenting to the aerosol particles too large a surface area on which they may condense.

**[0033]** In practice, in aerosol-generating articles in accordance with the invention, the cross-sectional surface area of the cavity of the hollow tubular segment may be maximised, whilst at the same time ensuring that the hollow tubular segment has the necessary structural strength to prevent a collapse of the aerosol-generating article as well as to provide some support to the rod of aerosol-generating substrate, and that the RTD of the hollow tubular segment is minimised. Greater values of cross-sectional surface area of the cavity of the hollow tubular segment are understood to be associated with a reduced speed of the aerosol stream travelling along the aerosol-generating article, which is also expected to favour aerosol nucleation.

**[0034]** Further, it would appear that by utilising a hollow tubular segment having a low thickness, such as a thickness below 1.5 millimetres, it is possible to substantially prevent diffusion of the ventilation air prior to its contacting and mixing with the stream of aerosol, which is also understood to further favour nucleation phenomena. In practice, by providing a more controllably localised cooling of the stream of volatilised species, it is possible to enhance the effect of cooling on the formation of new aerosol particles.

**[0035]** In fact, the inventors have surprisingly found how the favourable effect of enhanced nucleation may significantly counter the less desirable effects of dilution, such that satisfactory values of aerosol delivery are consistently achieved with aerosol-generating articles in accordance with the invention. This is particularly advantageous with “short” aerosol-generating articles, such as ones wherein a length of the rod of aerosol-generating substrate is less than about 40 millimetres, preferably less than 25 millimetres, even more preferably less than 20 millimetres, or wherein an overall length of the aerosol-generating article is less than about 70 millimetres, preferably less than about 60 millimetres, even more preferably less than 50 millimetres. As will be appreciated, in such aerosol-generating articles, there is little time and space for the aerosol to form and for the particulate phase of the aerosol to become available for delivery to the consumer.

**[0036]** Further, because the hollow tubular element substantially does not contribute to the RTD of the aerosol-generating article, in aerosol-generating articles in accordance with the invention the overall RTD of the article can advantageously be fine-tuned by adjusting the length and density of the rod of aerosol-generating substrate or the length and density of the segment of filtration material of the mouthpiece segment, in those embodiments where a mouthpiece segment is present. This enables the manufacture of aerosol-generating substrates having a predetermined RTD consistently and with great precision, such that satisfactory levels of RTD can be provided for the consumer even in the presence of ventilation.

**[0037]** Aerosol-generating articles in accordance with the invention can be made in a continuous process which can be efficiently carried out at high speed, and can be conveniently manufactured on existing production lines for the manufacture of heated aerosol generating articles without requiring extensive modifications of the manufacturing equipment.

**[0038]** The rod of aerosol generating substrate preferably has an external diameter that is approximately equal to the external diameter of the aerosol generating article.

**[0039]** Preferably, the rod of aerosol generating substrate has an external diameter of at least 5 millimetres. The rod of aerosol generating substrate may have an external diameter of between about 5 millimetres and about 12 millimetres, for example of between about 5 millimetres and about 10 millimetres or of between about 6 millimetres and about 8 millimetres. In a preferred embodiment, the rod of aerosol generating substrate has an external diameter of 7.2 millimetres, to within 10 percent.

**[0040]** The rod of aerosol generating substrate may have a length of between about 5 millimetres and about 100 mm. Preferably, the rod of aerosol generating substrate has a length of at least about 5 millimetres, more preferably at least about 7 millimetres. In addition, or as an alternative, the rod of aerosol generating substrate preferably has a length of less than about 80 millimetres, more preferably less than about 65 millimetres, even more preferably less than about 50 millimetres. In particularly preferred embodiments, the rod of aerosol generating substrate has a length of less than about 35 millimetres, more preferably less than 25 millimetres, even more preferably less than about 20 millimetres. In one embodiment, the rod of aerosol generating substrate may have a length of about 10 millimetres. In a preferred embodiment, the rod of aerosol generating substrate has a length of about 12 millimetres.

**[0041]** Preferably, the rod of aerosol generating substrate has a substantially uniform cross-section along the length of the rod. Particularly preferably, the rod of aerosol generating substrate has a substantially circular cross-section.

**[0042]** In preferred embodiments, the aerosol-generating substrate comprises one or more gathered sheets of homogenised tobacco material. Preferably the one or more sheets of homogenised tobacco material are textured. As used herein, the term ‘textured sheet’ denotes a sheet that has been crimped, embossed, debossed, perforated or otherwise deformed. Textured sheets of homogenised tobacco material for use in the invention may comprise a plurality of spaced-apart indentations, protrusions, perforations or a combination thereof. According to a particularly preferred embodiment of the invention, the rod of aerosol-generating substrate comprises a gathered crimped sheet of homogenised tobacco material circumscribed by a wrapper.

**[0043]** As used herein, the term ‘crimped sheet’ is intended to be synonymous with the term ‘creped sheet’ and denotes a sheet having a plurality of substantially parallel ridges or corrugations. Preferably, the crimped sheet of homogenised tobacco material has a plurality of ridges or corrugations substantially parallel to the cylindrical axis of the rod according to the invention. This advantageously facilitates gathering of the crimped sheet of homogenised tobacco material to form the rod. However, it will be appreciated that crimped sheets of homogenised tobacco material for use in the invention may alternatively or in addition have a plurality of substantially parallel ridges or corrugations disposed at an acute or obtuse angle to the

cylindrical axis of the rod. In certain embodiments, sheets of homogenised tobacco material for use in the rod of the article of the invention may be substantially evenly textured over substantially their entire surface. For example, crimped sheets of homogenised tobacco material for use in the manufacture of a rod for use in an aerosol-generating article in accordance with the invention may comprise a plurality of substantially parallel ridges or corrugations that are substantially evenly spaced-apart across the width of the sheet.

**[0044]** Sheets or webs of homogenised tobacco material for use in the invention may have a tobacco content of at least about 40 percent by weight on a dry weight basis, more preferably of at least about 60 percent by weight on a dry weight basis, more preferably or at least about 70 percent by weight on a dry basis and most preferably at least about 90 percent by weight on a dry weight basis.

**[0045]** Sheets or webs of homogenised tobacco material for use in the aerosol-generating substrate may comprise one or more intrinsic binders, that is tobacco endogenous binders, one or more extrinsic binders, that is tobacco exogenous binders, or a combination thereof to help agglomerate the particulate tobacco. Alternatively, or in addition, sheets of homogenised tobacco material for use in the aerosol-generating substrate may comprise other additives including, but not limited to, tobacco and non-tobacco fibres, aerosol-formers, humectants, plasticisers, flavourants, fillers, aqueous and non-aqueous solvents and combinations thereof.

**[0046]** Suitable extrinsic binders for inclusion in sheets or webs of homogenised tobacco material for use in the aerosol-generating substrate are known in the art and include, but are not limited to: gums such as, for example, guar gum, xanthan gum, arabic gum and locust bean gum; cellulosic binders such as, for example, hydroxypropyl cellulose, carboxymethyl cellulose, hydroxyethyl cellulose, methyl cellulose and ethyl cellulose; polysaccharides such as, for example, starches, organic acids, such as alginic acid, conjugate base salts of organic acids, such as sodium-alginate, agar and pectins; and combinations thereof.

**[0047]** Suitable non-tobacco fibres for inclusion in sheets or webs of homogenised tobacco material for use in the aerosol-generating substrate are known in the art and include, but are not limited to: cellulose fibres; soft-wood fibres; hard-wood fibres; jute fibres and combinations thereof. Prior to inclusion in sheets of homogenised tobacco material for use in the aerosol-generating substrate, non-tobacco fibres may be treated by suitable processes known in the art including, but not limited to: mechanical pulping; refining; chemical pulping; bleaching; sulphate pulping; and combinations thereof.

**[0048]** Preferably, the sheets or webs of homogenised tobacco material comprise an aerosol former. As used herein, the term ‘aerosol former’ describes any suitable known compound or mixture of compounds that, in use, facilitates formation of an aerosol and that is substantially resistant to thermal degradation at the operating temperature of the aerosol-generating article.

**[0049]** Suitable aerosol-formers are known in the art and include, but are not limited to: polyhydric alcohols, such as propylene glycol, triethylene glycol, 1,3-butanediol and glycerine; esters of polyhydric alcohols, such as glycerol mono-, di- or triacetate; and aliphatic esters of mono-, di- or polycarboxylic acids, such as dimethyl dodecanedioate and dimethyl tetradecanedioate.

**[0050]** Preferred aerosol formers are polyhydric alcohols or mixtures thereof, such as propylene glycol, triethylene glycol, 1,3-butanediol and, most preferred, glycerine.

**[0051]** The sheets or webs of homogenised tobacco material may comprise a single aerosol former. Alternatively, the sheets or webs of homogenised tobacco material may comprise a combination of two or more aerosol formers.

**[0052]** The sheets or webs of homogenised tobacco material have an aerosol former content of greater than 10 percent on a dry weight basis. Preferably, the sheets or webs of homogenised tobacco material have an aerosol former content of greater than 12 percent on a dry weight basis. More preferably, the sheets or webs of homogenised tobacco material have an aerosol former content of greater than 14 percent on a dry weight basis. Even more preferably the sheets or webs of homogenised tobacco material have an aerosol former content of greater than 16 percent on a dry weight basis.

**[0053]** The sheets of homogenised tobacco material may have an aerosol former content of between approximately 10 percent and approximately 30 percent on a dry weight basis. Preferably, the sheets or webs of homogenised tobacco material have an aerosol former content of less than 25 percent on a dry weight basis.

**[0054]** In a preferred embodiment, the sheets of homogenised tobacco material have an aerosol former content of approximately 20 percent on a dry weight basis.

**[0055]** Sheets or webs of homogenised tobacco for use in the aerosol-generating article of the present invention may be made by methods known in the art, for example the methods disclosed in International patent application WO-A-2012/164009 A2. In a preferred embodiment, sheets of homogenised tobacco material for use in the aerosol-generating article are formed from a slurry comprising particulate tobacco, guar gum, cellulose fibres and glycerine by a casting process.

**[0056]** Alternative arrangements of homogenised tobacco material in a rod for use in an aerosol-generating article will be known to the skilled person and may include a plurality of stacked sheets of homogenised tobacco material, a plurality of elongate tubular elements formed by winding strips of homogenised tobacco material about their longitudinal axes, etc.

**[0057]** As a further alternative, the rod of aerosol-generating substrate may comprise a non-tobacco-based, nicotine-bearing material, such as a sheet of sorbent non-tobacco material loaded with nicotine (for example, in the form of a nicotine salt) and an aerosol-former. Examples of such rods are described in the international application WO-A-2015/052652. In addition, or as an alternative, the rod of aerosol-generating substrate may comprise a non-tobacco plant material, such as an aromatic non-tobacco plant material.

**[0058]** In the rod of aerosol-generating substrate of articles in accordance with the invention, the aerosol-generating substrate is preferably circumscribed by a wrapper. The wrapper may be formed of a porous or non-porous sheet material. The wrapper may be formed of any suitable material or combination of materials. Preferably, the wrapper is a paper wrapper.

**[0059]** Aerosol-generating articles in accordance with the present invention may optionally comprise a mouthpiece segment at a location downstream of the hollow tubular segment, preferably in end-to-end abutment with the hollow

tubular segment. In these articles, the cavity of the hollow tubular segment extends all the way to an upstream end of the mouthpiece segment.

**[0060]** The mouthpiece typically comprises a plug of filtration material capable of removing particulate components, gaseous components or a combination. Suitable filtration materials are known in the art and include, but are not limited to: fibrous filtration materials such as, for example, cellulose acetate tow, viscose fibres, polyhydroxyalkanoates (PHA) fibres, polylactic acid (PLA) fibres and paper; adsorbents such as, for example, activated alumina, zeolites, molecular sieves and silica gel; and combinations thereof. In addition, the plug of filtration material may further comprise one or more aerosol-modifying agent. Suitable aerosol-modifying agents are known in the art and include, but are not limited to, flavourants such as, for example, menthol. In some embodiments, the mouthpiece may further comprise a mouth end recess downstream of the plug of filtration material. By way of example, the mouthpiece may comprise a hollow tube arranged in longitudinal alignment with, and immediately downstream of the plug of filtration material, the hollow tube forming a cavity at the mouth end that is open to the outer environment at the downstream end of the mouthpiece and of the aerosol-generating article.

**[0061]** A length of the mouthpiece is preferably at least about 4 millimetres, more preferably at least about 6 millimetres, even more preferably at least about 8 millimetres. In addition, or as an alternative, a length of the mouthpiece is preferably less than 25 millimetres, more preferably less than 20 millimetres, even more preferably less than 15 millimetres. In some preferred embodiments, a length of the mouthpiece is from about 4 millimetres to about 25 millimetres, more preferably from about 6 millimetres to about 20 millimetres. In an exemplary embodiment, a length of the mouthpiece is about 7 millimetres. In another exemplary embodiment, a length of the mouthpiece is about 12 millimetres.

**[0062]** In other embodiments, a similar segment of filtration material may alternatively or additionally be provided at a location between the rod of aerosol-generating substrate and the hollow tubular segment.

**[0063]** The hollow tubular segment is preferably an annular tube delimiting and defining an air gap within the aerosol-generating article. In practice, the hollow tubular segment provides a chamber for the volatilised aerosol components released upon heating the aerosol-generating substrate to accumulate and flow in. As described briefly above, this chamber extends longitudinally all the way from an upstream end of the hollow tubular segment to a downstream end of the hollow tubular segment.

**[0064]** Thus, in aerosol-generating articles in accordance with the invention, the hollow tubular segment maintains the rod of aerosol-generating substrate at a predetermined distance from the mouth end of the article and provides an elongate airflow conduit for the aerosol to form and flow towards the mouth end of the article. During use, a thermal gradient is established along this airflow conduit. In practice, a temperature differential is provided, such that a temperature of the volatilised aerosol components entering the hollow tubular segment at the upstream end is greater than a temperature of the volatilised aerosol components exiting the hollow tubular segment at the downstream end (that is, the upstream end of the mouthpiece, where a mouthpiece is present).

[0065] On the one hand, the hollow tubular segment is required to withstand any axial compressive load or bending moment that may be applied on the hollow tubular segment during manufacture of the aerosol-generating article. Further, the hollow tubular segment is required to impart structural strength to the aerosol-generating article, such that it can easily be handled by the consumer and inserted into an aerosol-generating device for use. On the other hand, it is desirable that the overall volume of the chamber internally defined by the hollow tubular element is as large as possible, so as to favour the formation of aerosol and enhance the delivery of aerosol to the consumer.

[0066] To satisfy these requirements, as described briefly above, a ratio between a weight of the hollow tubular segment and a volume of the internal cavity defined by the hollow tubular segment is less than 1 milligrams/cubic millimetres. More preferably, a ratio between a weight of the hollow tubular segment and a volume of the internal cavity defined by the hollow tubular segment is less than 0.5 milligrams/cubic millimetres. Even more preferably, a ratio between a weight of the hollow tubular segment and a volume of the internal cavity defined by the hollow tubular segment is less than 0.2 milligrams/cubic millimetres. In particularly preferred embodiments, a ratio between a weight of the hollow tubular segment and a volume of the internal cavity defined by the hollow tubular segment is less than 0.1 milligrams/cubic millimetres.

[0067] In hollow tubular segments having a ratio between a weight of the hollow tubular segment and a volume of the internal cavity defined by the hollow tubular segment falling within the ranges described above, the volume of the cavity is advantageously maximised, whilst ensuring that the hollow tubular segment contributes to the overall structural strength of the aerosol-generating article and effectively maintains the rod of aerosol-generating substrate spaced from the mouth end of the article.

[0068] In an exemplary embodiment, the hollow tubular segment has an internal equivalent diameter of 7 millimetres and is formed from a wrapper having a basis weight of 110 gsm, with a weight of 2.5 milligram/millimetre. For one such hollow tubular segment, the ratio between a weight of the hollow tubular segment and a volume of the internal cavity defined by the hollow tubular segment is about 0.065 milligrams/cubic millimetres.

[0069] In another exemplary embodiment, a hollow tubular segment has an internal equivalent diameter of 5.3 millimetres may be provided as a cellulose acetate tube with a weight of 9.5 milligram/millimetre. For one such hollow tubular segment, the ratio between a weight of the hollow tubular segment and a volume of the internal cavity defined by the hollow tubular segment is about 0.43 milligrams/cubic millimetres.

[0070] Preferably, a thickness of a peripheral wall of the hollow tubular segment is less than 1.5 millimetre. Preferably, the thickness of the peripheral wall of the hollow tubular segment is less than 1250 micrometres, more preferably less than 1000 micrometres, even more preferably less than 900 micrometres. In particularly preferred embodiments, the thickness of the peripheral wall of the hollow tubular segment is less than 800 micrometres.

[0071] In addition, or as an alternative, the thickness of the peripheral wall of the hollow tubular segment is at least

about 100 micrometres. Preferably, the thickness of the peripheral wall of the hollow tubular segment is at least about 200 micrometres.

[0072] Without wishing to be bound by theory, it would appear that by utilising a hollow tubular segment having a peripheral wall with a thickness falling within the ranges described above, it is advantageously possible to limit or even substantially prevent diffusion of the ventilation air prior to its contacting and mixing with the stream of aerosol. This is understood to further favour nucleation phenomena. In practice, by providing a more controllably localised cooling of the stream of volatilised species being drawn through the hollow tubular segment, it is possible to enhance the effect of cooling on the formation of new aerosol particles.

[0073] Preferably, an equivalent internal diameter of the hollow tubular segment is at least about 4 millimetres. The term "equivalent internal diameter" is used herein to denote the diameter of a circle having the same surface area of a cross-section of the airflow conduit internally defined by the hollow tubular segment. A cross-section of the airflow conduit may have any suitable shape. However, as described briefly above, a circular cross-section is preferred—that is, the hollow tubular segment is effectively a cylindrical tube. In that case, the equivalent internal diameter of the hollow tubular segment effectively coincides with the internal diameter of the cylindrical tube.

[0074] More preferably, an equivalent internal diameter of the hollow tubular segment is at least about 5 millimetres, even more preferably at least about 5.25 millimetres, most preferably at least about 5.5 millimetres. In some embodiments, an equivalent internal diameter of the hollow tubular segment is at least about 6 millimetres or at least about 6.5 millimetres or at least about 7 millimetres.

[0075] In addition, an equivalent internal diameter of the hollow tubular segment is preferably less than about 10 millimetres. More preferably, an equivalent internal diameter of the hollow tubular segment is less than about 9.5 millimetres, even more preferably less than 9 millimetres.

[0076] The equivalent internal diameter of the hollow tubular segment is measured at the location of the ventilation zone.

[0077] In preferred embodiments, the equivalent internal diameter of the hollow tubular segment is substantially constant along the length of the hollow tubular segment. In other embodiments, the equivalent internal diameter of the hollow tubular segment may vary along the length of the hollow tubular segment.

[0078] The inventors have surprisingly found that aerosol-generating articles in accordance with the invention that comprise a hollow tubular segment having an equivalent internal diameter within the ranges described above could provide particularly satisfactory values of aerosol delivery. Without wishing to be bound by theory, it is hypothesized that the aerosol stream flowing along a hollow tubular segment having an equivalent internal diameter falling within the ranges described above is caused to flow at a relatively low speed when the incoming flow of cooler ventilation air is received into and mixed with the aerosol stream. Because the aerosol stream advances relatively slowly along the hollow tubular segment, the favourable impact of cooling on aerosol nucleation is expected to be maximised under such conditions.

**[0079]** Preferably, an equivalent internal diameter of the hollow tubular segment is substantially constant along the length of the hollow tubular segment. However, in some embodiments, the cross-sectional surface area of the hollow tubular segment may vary along the length of the hollow tubular segment. In such embodiments, the equivalent internal diameter is measured at the location of the ventilation zone.

**[0080]** As described briefly above, aerosol-generating articles in accordance with the present invention comprise a ventilation zone at a location along the hollow tubular segment. Preferably, the ventilation zone is provided at a location less than about 18 millimetres from an upstream end of the hollow tubular segment. Preferably, a distance between the ventilation zone and an upstream end of the hollow tubular segment is less than about 15 millimetres. Even more preferably, a distance between the ventilation zone and upstream end of the hollow tubular segment is less than about 10 millimetres.

**[0081]** In addition, or as an alternative, a distance between the ventilation zone and an upstream end of the hollow tubular segment is preferably at least 2 millimetres. More preferably, a distance between the ventilation zone and an upstream end of the hollow tubular segment is at least about 4 millimetres. Even more preferably, a distance between the ventilation zone and an upstream end of the hollow tubular segment is at least about 6 millimetres.

**[0082]** In those embodiments of aerosol-generating articles in accordance with the invention comprising a mouthpiece, the ventilation zone is preferably provided at a location along the hollow tubular segment at least 2 millimetres from the upstream end of the mouthpiece. Preferably, the ventilation zone is provided at a location along the hollow tubular segment at least 4 millimetres from the upstream end of the mouthpiece. Even more preferably, the ventilation zone is provided at a location along the hollow tubular segment at least 6 millimetres from the upstream end of the mouthpiece.

**[0083]** As the mixture of air and aerosol particles flowing through the aerosol-generating article reaches the ventilation zone, external air drawn into the hollow tubular segment via the ventilation zone is mixed with the aerosol. This rapidly reduces the temperature of the aerosol mixture whilst partially diluting the mixture of air and aerosol particles. However, by providing the ventilation zone at a distance from the upstream end of the mouthpiece segment falling within the ranges described above, a cooling chamber is effectively provided immediately upstream of the mouthpiece, wherein nucleation and growth of aerosol particles is advantageously favoured. As such, the diluting effect of the ventilation air admitted into the hollow tubular segment is at least partly countered, which advantageously enables the provision of aerosol delivery levels that are satisfactory for the consumer.

**[0084]** In some embodiments, a ratio between the distance between the ventilation zone and an upstream end of the hollow tubular segment and an equivalent internal diameter of the hollow tubular segment at the location of the ventilation zone is less than 4. Preferably, a ratio between the distance between the ventilation zone and an upstream end of the hollow tubular segment and an equivalent internal diameter of the hollow tubular segment at the location of the ventilation zone is less than 3.5. More preferably, a ratio between the distance between the ventilation zone and an

upstream end of the hollow tubular segment and an equivalent internal diameter of the hollow tubular segment at the location of the ventilation zone is less than 3. Even more preferably, a ratio between the distance between the ventilation zone and an upstream end of the hollow tubular segment and an equivalent internal diameter of the hollow tubular segment at the location of the ventilation zone is less than 2.5.

**[0085]** In particularly preferred embodiments, a ratio between the distance between the ventilation zone and an upstream end of the hollow tubular segment and an equivalent internal diameter of the hollow tubular segment at the location of the ventilation zone is less than 2, more preferably less than 1.5, even more preferably less than 1.2.

**[0086]** Preferably, the ventilation zone is provided at a location along the hollow tubular segment at least 10 millimetres from a downstream end of the aerosol-generating article. More preferably, the ventilation zone is provided at a location along the hollow tubular segment at least 12 millimetres from a downstream end of the aerosol-generating article. Even more preferably, the ventilation zone is provided at a location along the hollow tubular segment at least 15 millimetres from a downstream end of the aerosol-generating article. This is advantageous in that it ensures that, during use, the ventilation zone is not occluded by the consumer's lips.

**[0087]** In addition, or as an alternative, the ventilation zone is preferably at a location along the hollow tubular segment less than 25 millimetres from a downstream end of the aerosol-generating article. More preferably, the ventilation zone is at a location along the hollow tubular segment less than 20 millimetres from a downstream end of the aerosol-generating article. This advantageously ensures that during use, when the aerosol-generating article is received within a heating chamber of an electrically heated aerosol-generating device, the ventilation zone is effectively at a location along the hollow tubular segment that projects outside of the heating chamber, such that external cooling air can easily be drawn into the hollow tubular segment.

**[0088]** In some preferred embodiments, the ventilation zone is provided at a location along the hollow tubular segment from about 10 millimetres to about 25 millimetres from a downstream end of the aerosol-generating device, more preferably from about 12 millimetres to about 20 millimetres from a downstream end of the aerosol-generating device. In an exemplary embodiment, the ventilation zone is provided at a location along the hollow tubular segment 18 millimetres from the downstream end of the aerosol-generating device. In another exemplary embodiment, the ventilation zone is provided at a location along the hollow tubular segment 13 millimetres from the downstream end of the aerosol-generating device.

**[0089]** The aerosol-generating article may typically have a ventilation level of at least about 10 percent, preferably at least about 20 percent.

**[0090]** In preferred embodiments, the aerosol-generating article has a ventilation level of at least about 30 percent. More preferably, the aerosol-generating article has a ventilation level of at least about 35 percent. In addition, or as an alternative, the aerosol-generating article preferably has a ventilation level of less than about 60 percent. More preferably, the aerosol-generating article has a ventilation level of less than about 50 percent. In particularly preferred embodiments, the aerosol-generating article has a ventila-

tion level from about 30 percent to about 60 percent. More preferably, the aerosol-generating article has a ventilation level from about 35 percent to about 50 percent. In some particularly preferred embodiments, the aerosol-generating article has a ventilation level of about 40 percent.

**[0091]** Without wishing to be bound by theory, the inventors have found that the temperature drop caused by the admission of cooler, external air into the hollow tubular segment via the ventilation zone may have an advantageous effect on the nucleation and growth of aerosol particles.

**[0092]** Formation of an aerosol from a gaseous mixture containing various chemical species depends on a delicate interplay between nucleation, evaporation, and condensation, as well as coalescence, all the while accounting for variations in vapour concentration, temperature, and velocity fields. The so-called classical nucleation theory is based on the assumption that a fraction of the molecules in the gas phase are large enough to stay coherent for long times with sufficient probability (for example, a probability of one half). These molecules represent some kind of a critical, threshold molecule clusters among transient molecular aggregates, meaning that, on average, smaller molecule clusters are likely to disintegrate rather quickly into the gas phase, while larger clusters are, on average, likely to grow. Such critical cluster is identified as the key nucleation core from which droplets are expected to grow due to condensation of molecules from the vapour. It is assumed that virgin droplets that just nucleated emerge with a certain original diameter, and then may grow by several orders of magnitude. This is facilitated and may be enhanced by rapid cooling of the surrounding vapour, which induces condensation. In this connection, it helps to bear in mind that evaporation and condensation are two sides of one same mechanism, namely gas-liquid mass transfer. While evaporation relates to net mass transfer from the liquid droplets to the gas phase, condensation is net mass transfer from the gas phase to the droplet phase. Evaporation (or condensation) will make the droplets shrink (or grow), but it will not change the number of droplets.

**[0093]** In this scenario, which may be further complicated by coalescence phenomena, the temperature and rate of cooling can play a critical role in determining how the system responds. In general, different cooling rates may lead to significantly different temporal behaviours as concerns the formation of the liquid phase (droplets), because the nucleation process is typically nonlinear. Without wishing to be bound by theory, it is hypothesised that cooling can cause a rapid increase in the number concentration of droplets, which is followed by a strong, short-lived increase in this growth (nucleation burst). This nucleation burst would appear to be more significant at lower temperatures. Further, it would appear that higher cooling rates may favour an earlier onset of nucleation. By contrast, a reduction of the cooling rate would appear to have a favourable effect on the final size that the aerosol droplets ultimately reach.

**[0094]** Therefore, the rapid cooling induced by the admission of external air into the hollow tubular segment via the ventilation zone can be favourably used to favour nucleation and growth of aerosol droplets. However, at the same time, the admission of external air into the hollow tubular segment has the immediate drawback of diluting the aerosol stream delivered to the consumer.

**[0095]** The inventors have surprisingly found that the diluting effect on the aerosol—which can be assessed by

measuring, in particular, the effect on the delivery of glycerin included in the aerosol-generating substrate as the aerosol former—is advantageously minimised when the ventilation level is between 30 percent and 50 percent. In particular, ventilation levels between 35 percent and 42 percent have been found to lead to particularly satisfactory values of glycerin delivery.

**[0096]** In addition, the inventors have found that in aerosol-generating articles in accordance with the invention the cooling and diluting effect caused by the admission of ventilation air at the location along the conduit defined by the hollow tubular segment described above has a surprising reducing effect on the generation and delivery of phenol-containing species.

**[0097]** The ventilation zone may comprise one or more rows of perforations formed through the peripheral wall of the hollow tubular segment. Preferably the ventilation zone comprises only one row of perforations. This is understood to be advantageous in that, by concentrating the cooling effect brought about by ventilation over a short portion of the cavity defined by the hollow tube segment, it may be possible to further enhance aerosol nucleation. This is because a faster and more drastic cooling of the stream of volatilised species is expected to particularly favour the formation of new nuclei of aerosol particles.

**[0098]** Preferably, the one or more rows of perforations are arranged circumferentially around the wall of the hollow tube. Where the ventilation zone comprises two or more rows of perforations formed through the peripheral wall of the hollow tubular segment, the rows are longitudinally spaced apart from one another along the hollow tubular segment. By way of example, adjacent rows of perforations may be longitudinally spaced from one another by a distance of between about 0.25 millimetres and 0.75 millimetres.

**[0099]** An equivalent diameter of at least one of the ventilation perforations is preferably at least about 100 micrometres. Preferably, an equivalent diameter of at least one of the ventilation perforations is at least about 150 micrometres. Even more preferably, an equivalent diameter of at least one of the ventilation perforations is at least about 200 micrometres. In addition, or as an alternative, an equivalent diameter of at least one of the ventilation perforations is preferably less than about 500 micrometres. More preferably, an equivalent diameter of at least one of the ventilation perforations is less than about 450 micrometres. Even more preferably, an equivalent diameter of at least one of the ventilation perforations is less than about 400 micrometres. The term “equivalent diameter” is used herein to denote the diameter of a circle having the same surface area of a cross-section of the ventilation perforation. A cross-section of the ventilation perforations may have any suitable shape. However, circular ventilation perforations are preferred.

**[0100]** The ventilation perforations may be of uniform size. As an alternative, the ventilation perforations may vary in size. By varying the number and size of the ventilation perforations, it is possible to adjust the amount of external air admitted into the hollow tubular segment when the consumer draws on the mouth end of the aerosol-generating article during use. As such, it is advantageously possible to adjust the ventilation level of the aerosol-generating article.

**[0101]** The ventilation perforations can be formed using any suitable technique, for example by laser technology, mechanical perforation of the hollow tubular segment as part of the aerosol-generating article or pre-perforation of the

hollow tubular segment before it is combined with the other elements to form the aerosol-generating article. Preferably, the ventilation perforations are formed by online laser perforation.

**[0102]** A length of the hollow tubular segment is preferably at least about 10 millimetres. More preferably, a length of the hollow tubular segment is at least about 15 millimetres. In addition, or as an alternative, a length of the hollow tubular segment is preferably less than about 30 millimetres. More preferably, a length of the hollow tubular segment is less than about 25 millimetres. Even more preferably, a length of the hollow tubular segment is less than about 20 millimetres. In some preferred embodiments, a length of the hollow tubular segment is from about 10 millimetres to about 30 millimetres, more preferably from about 12 millimetres to about 25 millimetres, even more preferably from about 15 millimetres to about 20 millimetres. By way of example, in a particularly preferred embodiment the length of the hollow tubular segment is about 18 millimetres. In another particularly preferred embodiment the length of the hollow tubular segment is about 13 millimetres.

**[0103]** An overall length of an aerosol-generating article in accordance with the invention is preferably at least about 40 millimetres. In addition, or as an alternative, an overall length of the aerosol-generating article in accordance with the invention is preferably less than about 70 millimetres, more preferably less than 60 millimetres, even more preferably less than 50 millimetres. In preferred embodiments, an overall length of the aerosol-generating article is from about 40 millimetres to about 70 millimetres. In an exemplary embodiment, an overall length of the aerosol-generating article is about 45 millimetres.

**[0104]** The hollow tubular segment is preferably formed from a substantially air-impervious material. Accordingly, air and aerosol particles drawn through the hollow tubular segment are forced to flow through the hollow tubular segment from its upstream end to its downstream end, but cannot flow across the peripheral wall of the hollow tubular element.

**[0105]** In some embodiments, the hollow tubular segment comprises a wrapper, the wrapper also circumscribing the rod. Where a mouthpiece segment is present, the wrapper also circumscribes the mouthpiece segment. In practice, a wrapper having a thickness falling within the ranges described above is used for circumscribing and connecting the rod of aerosol-generating substrate (and optionally the mouthpiece segment), the wrapper effectively forming the peripheral wall of the hollow tubular element.

**[0106]** By way of example, one such combining wrapper connecting the rod and the mouthpiece segment may have a basis weight of less at least about 70 grams/square metre (gsm). Preferably, one such combining wrapper connecting the rod and the mouthpiece segment has a basis weight of at least about 80 grams/square metre, more preferably at least about 90 grams/square metre. In particularly preferred embodiments, the combining wrapper connecting the rod and the mouthpiece segment has a basis weight of at least about 110 grams/square metre, more preferably at least about 130 grams/square metre.

**[0107]** In other embodiments, the hollow tubular segment comprises a tube formed from a polymeric material or a cellulosic material, the heated aerosol-generating article further comprising a wrapper circumscribing the rod, the tube and the optional mouthpiece segment. By way of

example, the cellulosic material may comprise paper or cardboard or a mixture thereof.

**[0108]** By way of example, the hollow tubular segment can comprise a tube formed from an extruded plastic tube. As an alternative, the hollow tubular segment may comprise a tube formed from a plurality of overlapping paper layers, such as a plurality of parallel wound paper layers or a plurality of spirally wound paper layers. Forming tube from a plurality of overlapping paper layers can help to further improve resistance to collapse or deformation. Preferably the tube comprises two or more paper layers. Alternatively, or additionally, the tube preferably comprises fewer than eleven paper layers.

**[0109]** One such tube may be made air-impervious by using a substantially air-impermeable paper. The term “substantially air-impermeable paper” is used herein to denote a paper having an air permeability of less than about 20 CORESTA units, more preferably less than about 10 CORESTA units, most preferably less than about 5 CORESTA units as measured in accordance with ISO 2965: 2009. As an alternative, adjacent paper layers in the tube may be held together with an adhesive imparting sealing properties to the tube.

**[0110]** Suitable materials for forming the tube are known in the art and comprise, but are not limited to, cellulose acetate, stiff paper (that is, paper having a basis weight of at least 90 grams/square metre), polymeric films, such as cellulosic films, and cardboard.

**[0111]** In aerosol-generating articles in accordance with the present invention the overall RTD of the article depends essentially on the RTD of the rod and, where a mouthpiece is present, on the RTD of the mouthpiece, as the hollow tubular segment is substantially empty and, as such, substantially only marginally contribute to the overall RTD. In practice, the hollow tubular segment may be adapted to generate a RTD in the range of approximately 1 millimetre H<sub>2</sub>O (about 10 Pa) to approximately 20 millimetres H<sub>2</sub>O (about 200 Pa). Preferably, the hollow tubular segment is adapted to generate a RTD between approximately 2 millimetres H<sub>2</sub>O (about 20 Pa) to approximately 10 millimetres H<sub>2</sub>O (about 100 Pa).

**[0112]** The aerosol-generating article preferably has an overall RTD of less than about 90 millimetres H<sub>2</sub>O (about 900 Pa). More preferably, the aerosol-generating article has an overall RTD of less than about 80 millimetres H<sub>2</sub>O (about 800 Pa). Even more preferably, the aerosol-generating article has an overall RTD of less than about 70 millimetres H<sub>2</sub>O (about 700 Pa).

**[0113]** In addition, or as an alternative, the aerosol-generating article preferably has an overall RTD of at least about 30 millimetres H<sub>2</sub>O (about 300 Pa). More preferably the aerosol-generating article has an overall RTD of at least about 40 millimetres H<sub>2</sub>O (about 400 Pa). Even more preferably, the aerosol-generating article has an overall RTD of at least about 50 millimetres H<sub>2</sub>O (about 500 Pa).

**[0114]** The RTD of the aerosol-generating article may be assessed as the negative pressure that has to be applied, under test conditions as defined in ISO 3402, to downstream end of the article (of the mouthpiece segment, where a mouthpiece segment is present) in order to sustain a steady volumetric flow of air of 17.5 ml/s through the mouthpiece segment. The values of RTD listed above are intended to be measured on the aerosol-generating article on its own (that

is, prior to inserting the article into an aerosol-generating device) without blocking the perforations of the ventilation zone.

**[0115]** If desired or required, for example to achieve a sufficiently high RTD of the aerosol-generating article, the length and density (denier per filament count) of the filtration material of the optional mouthpiece may be adjusted. In addition, or as an alternative, an additional filter section may be included in the aerosol-generating article. By way of example, such additional filter section may be included between the rod of aerosol-generating substrate and the hollow tubular segment. Preferably, such additional filter section comprises a filtration material such as, for example, cellulose acetate. Preferably, the length of the additional filter section is between about 4 millimetres and about 8 millimetres, preferably, between about 5 millimetres and about 7 millimetres.

**[0116]** In some embodiments, the aerosol-generating article in accordance with the invention may comprise an additional support element arranged between, and in longitudinal alignment with, the rod of aerosol-generating substrate and the hollow tubular segment. In more detail, the support element is preferably provided immediately downstream of the rod and immediately upstream of the hollow tubular element.

**[0117]** The support element is provided as a tubular element. The support element may be formed from any suitable material or combination of materials. For example, the support element may be formed from one or more materials selected from the group consisting of: cellulose acetate; cardboard; crimped paper, such as crimped heat resistant paper or crimped parchment paper; and polymeric materials, such as low density polyethylene (LDPE). In preferred embodiment, the support element is provided as a hollow cellulose acetate tube.

**[0118]** The support element preferably has an external diameter that is about equal to the external diameter of the aerosol-generating article. The support element may have an external diameter of between about 5 millimetres and about 12 millimetres, for example of between about 5 millimetres and about 10 millimetres or of between about 6 millimetres and about 8 millimetres. In a preferred embodiment, the support element has an external diameter of about 7.2 millimetres.

**[0119]** A peripheral wall of the support element may have a thickness of at least 1 millimetre, preferably at least about 1.5 millimetres, more preferably at least about 2 millimetres.

**[0120]** The support element may have a length of between about 5 millimetres and about 15 millimetres. In an preferred embodiment, the support element has a length of about 8 millimetres.

**[0121]** During insertion of a heating element of an aerosol-generating device into an aerosol-forming substrate of an aerosol-generating article, a user may be required to apply some force in order to overcome the resistance of the aerosol-forming substrate of the aerosol-generating article to insertion of the heating element of the aerosol-generating device. This may damage one or both of the aerosol-generating article and the heating element of the aerosol-generating device. In addition, the application of force during insertion of the heating element of the aerosol-generating device into the aerosol-forming substrate of the aerosol-generating article may displace the aerosol-forming substrate within the aerosol-generating article. This may

result in the heating element of the aerosol-generating device not being fully inserted into the aerosol-forming substrate, which may lead to uneven and inefficient heating of the aerosol-forming substrate of the aerosol-generating article. The support element is advantageously configured to resist downstream movement of the aerosol-forming substrate during insertion of the heating element of the aerosol-generating device into the aerosol-forming substrate of aerosol-generating article.

**[0122]** Preferably, a distance between the ventilation zone and an upstream end of the aerosol-generating article is less than about 50 millimetres. More preferably, a distance between the ventilation zone and an upstream end of the aerosol-generating article is less than about 45 millimetres. Even more preferably, a distance between the ventilation zone and an upstream end of the aerosol-generating article is less than about 40 millimetres.

**[0123]** In addition, or as an alternative, a distance between the ventilation zone and an upstream end of the aerosol-generating article is preferably at least about 12 millimetres. More preferably, a distance between the ventilation zone and an upstream end of the aerosol-generating article is preferably at least about 15 millimetres. Even more preferably, a distance between the ventilation zone and an upstream end of the aerosol-generating article is preferably at least about 20 millimetres. In particularly preferred embodiments, a distance between the ventilation zone and an upstream end of the aerosol-generating article is preferably at least about 25 millimetres.

**[0124]** A distance between the ventilation zone and a downstream end of the rod of aerosol-generating substrate is typically at least about 2 millimetres. Preferably, a distance between the ventilation zone and a downstream end of the rod of aerosol-generating substrate is at least about 4 millimetres. More preferably, a distance between the ventilation zone and a downstream end of the rod of aerosol-generating substrate is at least about 5 millimetres. Even more preferably, a distance between the ventilation zone and a downstream end of the rod of aerosol-generating substrate is at least about 10 millimetres. In some, particularly preferred embodiments, a distance between the ventilation zone and a downstream end of the rod of aerosol-generating substrate may be at least about 15 millimetres.

**[0125]** In addition, or as an alternative, a distance between the ventilation zone and a downstream end of the rod of aerosol-generating substrate is preferably less than about 35 millimetres. More preferably, a distance between the ventilation zone and a downstream end of the rod of aerosol-generating substrate is less than about 30 millimetres. Even more preferably, a distance between the ventilation zone and a downstream end of the rod of aerosol-generating substrate is less than about 25 millimetres.

**[0126]** In practice, the ventilation zone divides the cavity internally defined by the hollow tubular segment into an upstream sub-cavity, which extends longitudinally from an upstream end of the hollow tubular segment to the location of the ventilation zone, and a downstream sub-cavity, which extends longitudinally from the location of the ventilation zone to the downstream end of the hollow tubular segment. Without wishing to be bound by theory, it is understood that in the upstream sub-cavity the volatilised species of the aerosol stream advance along the hollow tubular segment slowly cool down by yielding some of the heat to the peripheral wall of the hollow tubular segment and thus

aerosol particles begin to nucleate. On the other hand, in the downstream sub-cavity, the aerosol stream and the ventilation air rapidly mix up, which causes a quick cooling of the volatilised species of the aerosol stream and so favours the nucleation of new aerosol particles and the growth of already existing aerosol particles as the aerosol advances towards the mouth end of the article.

**[0127]** Preferably, a ratio between a length of the upstream cavity and a length of the downstream cavity is less than 1.5. More preferably, a ratio between a length of the upstream cavity and a length of the downstream cavity is less than 1. Even more preferably, a ratio between a length of the upstream cavity and a length of the downstream cavity is less than 0.67.

**[0128]** In addition, or as an alternative, a ratio between a length of the upstream cavity and a length of the downstream cavity is preferably at least about 0.15. More preferably, a ratio between a length of the upstream cavity and a length of the downstream cavity is preferably at least about 0.2. Even more preferably, a ratio between a length of the upstream cavity and a length of the downstream cavity is preferably at least about 0.35.

**[0129]** Similarly, the ventilation zone divides the aerosol-generating article in two sections, upstream and downstream of the location of the ventilation zone, respectively.

**[0130]** Preferably, a ratio between a length of the upstream section of the aerosol-generating article and a length of the downstream section of the aerosol-generating article is less than 2.5. More preferably, a ratio between a length of the upstream section of the aerosol-generating article and a length of the downstream section of the aerosol-generating article is less than 2. Even more preferably, a ratio between a length of the upstream section of the aerosol-generating article and a length of the downstream section of the aerosol-generating article is less than 1.5. In particularly preferred embodiments, a ratio between a length of the upstream section of the aerosol-generating article and a length of the downstream section of the aerosol-generating article is less than 1.

**[0131]** In addition, or as an alternative, a ratio between a length of the upstream section of the aerosol-generating article and a length of the downstream section of the aerosol-generating article is preferably at least about 0.25. More preferably, a ratio between a length of the upstream section of the aerosol-generating article and a length of the downstream section of the aerosol-generating article is at least about 0.33. Even more preferably, a ratio between a length of the upstream section of the aerosol-generating article and a length of the downstream section of the aerosol-generating article is at least about 0.5.

**[0132]** In aerosol-generating articles in accordance with the invention it is advantageously easy to adjust and control the overall RTD of the article. This is because the overall RTD of the article depends on the RTD of a finite, small number of components and the provision of the ventilation zone also contributes to lowering the overall RTD of the article. Therefore, it is advantageously possible to reduce an RTD variability between aerosol-generating articles.

**[0133]** Accordingly, the invention may also provide a pack comprising ten or more aerosol-generating articles as described above, wherein a difference between an RTD of the aerosol-generating article having the highest RTD among the at least ten aerosol-generating articles and an RTD of the aerosol-generating article having the lowest

RTD among the at least ten aerosol-generating articles is less than 10 mm H<sub>2</sub>O (about 100 Pascal). Preferably, in one such pack, the difference between an RTD of the aerosol-generating article having the highest RTD among the at least ten aerosol-generating articles and an RTD of the aerosol-generating article having the lowest RTD among the at least ten aerosol-generating articles is less than 9 mm H<sub>2</sub>O (about 90 Pascal), more preferably less than 8 mm H<sub>2</sub>O (about 80 Pascal), even more preferably less than 7 mm H<sub>2</sub>O (about 70 Pascal).

**[0134]** In the following, the invention will be further described with reference to the drawings of the accompanying figures, in which:

**[0135]** FIG. 1 shows a schematic side sectional view of an aerosol-generating article in accordance with the invention;

**[0136]** FIG. 2 shows a schematic side sectional view of another example of an aerosol-generating article in accordance with the invention; and

**[0137]** FIG. 3 shows a schematic side sectional view of a further example an aerosol-generating article in accordance with the invention.

**[0138]** The aerosol-generating article **10** shown in FIG. 1 comprises a rod of aerosol-generating substrate **12**, a hollow cellulose acetate tube **14**, a hollow tubular segment **16** and a mouthpiece segment **18**. These four elements are arranged in end-to-end, longitudinal alignment and are circumscribed by a wrapper **20** to form the aerosol-generating article **10**. The aerosol-generating article **10** has a mouth end **22** and an upstream, distal end **24** located at the opposite end of the article to the mouth end **22**. The aerosol-generating article **10** shown in FIG. 1 is particularly suitable for use with an electrically operated aerosol-generating device comprising a heater for heating the rod of aerosol-generating substrate.

**[0139]** The rod of aerosol-generating substrate **12** has a length of about 12 millimetres and a diameter of about 7 millimetres. The rod **12** is cylindrical in shape and has a substantially circular cross-section. The rod **12** comprises a gathered sheet of homogenised tobacco material. The sheet of homogenised tobacco material comprises 10 percent by weight on a dry basis of glycerine. The hollow cellulose acetate tube **14** has a length of about 8 millimetres and a thickness of 1 millimetre.

**[0140]** The mouthpiece segment **18** comprises a plug of cellulose acetate tow of 8 denier per filament and has a length of about 7 millimetres.

**[0141]** The hollow tubular segment **14** is provided as a cylindrical tube having a length of about 18 millimetres and a thickness of the tube wall is about 100 micrometres.

**[0142]** In more detail, the hollow tubular segment **16** may for example be formed from a paper having a basis weight of 110 gsm and has a weight of 45 milligrams (that is, 2.5 milligrams/millimetre of length). An equivalent internal diameter of the hollow tubular segment **16** is about 7 millimetres. Thus, a volume of the cavity internally defined by the hollow tubular segment **16** is about 693 cubic millimetres. As such, a ratio between the weight of the hollow tubular segment and the volume of the internal cavity defined by the hollow tubular segment **16** is about 0.065.

**[0143]** The aerosol-generating article **10** comprises a ventilation zone **26** provided at about 5 millimetres from an upstream end of the mouthpiece segment **18**. Thus, the ventilation zone **26** is at about 12 millimetres from the downstream end of the aerosol-generating article, and about 13 millimetres from the upstream end of the hollow tubular

segment. Thus, the ventilation zone **26** is at about 21 millimetres from a downstream end of the rod **12**.

**[0144]** FIG. 2 illustrates another example of an aerosol-generating article in accordance with the invention. The aerosol-generating article **30** of FIG. 2 has the same structure of the aerosol-generating article **10** of FIG. 1 and differs from the aerosol-generating article **10** substantially only in the length of certain components, and will be described below only insofar as it differs from the aerosol-generating article **10**. In the following the same reference numerals will be used, wherever possible, for corresponding components having the same structural or functional function.

**[0145]** In the aerosol-generating article **30** of FIG. 2, the rod **12** and the hollow cellulose acetate tube **14** have the same length as in the aerosol-generating article **10** of FIG. 1. However, the mouthpiece segment comprises a plug of cellulose acetate tow of 11 denier per filament and having a length of about 12 millimetres, and a hollow tubular segment **14** having a length of about 13 millimetres. The ventilation zone **26** is provided at about 6 millimetres from the upstream end of the mouthpiece segment **18**, and at about 7 millimetres from the upstream end of the hollow tubular segment. Thus, the ventilation zone **26** is at about 15 millimetres from a downstream end of the rod **12**.

**[0146]** In the embodiment of FIG. 2, the hollow tubular segment **16** may for example be provided as a cylindrical tube of cellulose acetate having a length of about 18 millimetres and a peripheral wall thickness of about 1 millimetre, with a weight of 171 milligrams (that is, 9.5 milligrams/millimetre of length).

**[0147]** An equivalent internal diameter of the hollow tubular segment **16** may be about 5.3 millimetres. Thus, a volume of the cavity internally defined by the hollow tubular segment **16** is about 397 cubic millimetres. As such, a ratio between the weight of the hollow tubular segment and the volume of the internal cavity defined by the hollow tubular segment **16** is about 0.43. FIG. 3 illustrates yet another example of an aerosol-generating article in accordance with the invention. The aerosol-generating article **40** of FIG. 3 differs structurally from the aerosol-generating articles **10** of FIGS. 1 and **30** of FIG. 2 in that it does not include a hollow cellulose acetate tube as a support element. Accordingly, the lengths of the three main components are also different. In the following the same reference numerals will be used, wherever possible, for corresponding components having the same structural or functional function.

**[0148]** In the aerosol-generating article **40** of FIG. 3, the rod **12** has a length of about 12 millimetres, the hollow tubular segment **14** has a length of about 26 millimetres, and the mouthpiece segment **18** comprises a plug of cellulose acetate tow has a length of about 12 millimetres and 11 denier per filament. The ventilation zone **26** is provided at about 5 millimetres from the upstream end of the mouthpiece segment **18**, and at about 21 millimetres from the upstream end of the hollow tubular segment, which in this embodiment coincides with the downstream end of the rod **12**.

**[0149]** The following example records experimental results obtained during tests carried out on a specific embodiment of an aerosol-generating article in accordance with the present invention. Conditions for smoking and smoking machine specifications are set out in ISO Standard 3308 (ISO 3308:2000). The atmosphere for conditioning and testing is set out in ISO Standard 3402.

**[0150]** EXAMPLE 1 This experiment is performed to assess the effect of incorporation of a hollow tubular segment wherein a ventilation zone is provided at a location along the hollow tubular segment in accordance with the present invention. The experiment investigates the effect of the ventilation level on the delivery of nicotine and aerosol former (glycerin). A comparative measurement with a reference aerosol-generating article without ventilation is also provided.

**[0151]** Materials and Methods

**[0152]** Article A is an aerosol-generating article formed of: a rod of aerosol-generating substrate comprising a gathered sheet of homogenised tobacco material and about 18 percent on a dry weight basis of glycerin, the rod having a length of 12 millimetres; a support element in the form of a hollow cellulose acetate tube in alignment with and immediately downstream of the rod, the support element having a length of 8 millimetres; a hollow tubular segment in the form of a cardboard tube in alignment with and immediately downstream of the rod, the hollow tubular segment having a length of 13 millimetres; a mouthpiece segment of filtration material in alignment with and immediately downstream of the hollow tubular segment, the mouthpiece segment having a length of 12 millimetres. A ventilation zone is provided at a location along the hollow tubular segment at 18 millimetres from a downstream end of the mouthpiece segment. A level of ventilation of aerosol-generating article A is 30 percent.

**[0153]** Article B is a reference aerosol-generating article having the same structure of article A, but without the ventilation zone. Thus, a level of ventilation of aerosol-generating article B is 0 percent.

**[0154]** Nicotine and glycerin deliveries are measured by gas chromatography/time-of-flight mass spectrometry (GC/MS-TOF) on the nicotine and glycerin collected on a Cambridge filter pad. Runs were performed as described in example 1

**[0155]** Results. The average nicotine and glycerin deliveries from Article A and Article B are shown in the following Table 1.

TABLE 1

Effect of ventilation level on nicotine and glycerin deliveries.			
	Ventilation [%]	Nicotine delivery [mg]	Glycerin [mg]
Article A	30	1.41	5.6
Article B	0	1.17	3.5

1.-15. (canceled)

**16.** An aerosol-generating article for producing an inhalable aerosol upon heating, the aerosol-generating article comprising:

- a rod of aerosol-generating substrate;
- a hollow tubular segment at a location downstream of the rod, the hollow tubular segment being in longitudinal alignment with the rod, wherein the hollow tubular segment defines a cavity extending from an upstream end of the hollow tubular segment to a downstream end of the hollow tubular segment;
- a mouthpiece segment at a location downstream of the hollow tubular segment, the mouthpiece segment com-

prising a plug of filtration material and a mouth end recess downstream of the plug of filtration material; and

a ventilation zone at a location along the hollow tubular segment less than 20 millimetres from a downstream end of the aerosol-generating article, the ventilation zone comprising one or more rows of perforations formed through a peripheral wall of the hollow tubular segment,

wherein the hollow tubular segment has a length of about 25 millimetres,

wherein a ratio between a weight of the hollow tubular segment and a volume of the cavity defined by the hollow tubular segment is less than 1 milligram/cubic millimetres, and

wherein the rod of aerosol-generating substrate comprises at least an aerosol former, the rod of aerosol-generating substrate having an aerosol former content of at least about 12 percent on a dry weight basis.

**17.** The aerosol-generating article according to claim 16, wherein the hollow tubular segment comprises a wrapper circumscribing the rod.

**18.** The aerosol-generating article according to claim 16, wherein the hollow tubular segment comprises a tube formed from a polymeric material or a cellulosic material, and

wherein the heated aerosol-generating article further comprises a wrapper circumscribing the rod and the tube.

**19.** The aerosol-generating article according to claim 16, wherein a ratio between a weight of the hollow tubular segment and a volume of the cavity defined by the hollow tubular segment is less than 0.2 milligrams/cubic millimetres.

**20.** The aerosol-generating article according to claim 16, wherein an internal equivalent diameter of the hollow tubular segment is at least about 5 millimetres at the location of the ventilation zone.

**21.** The aerosol-generating article according to claim 16, wherein an internal equivalent diameter of the hollow tubular segment is less than about 9 millimetres at the location of the ventilation zone.

**22.** The aerosol-generating article according to claim 16, wherein the mouthpiece segment further comprises a mouth end hollow tube that defines the mouth end recess, the mouth end hollow tube being disposed in longitudinal alignment with, and immediately downstream of, the plug of filtration material, the recess being open to an outer environment at a downstream end of the mouthpiece segment and of the aerosol-generating article.

**23.** The aerosol-generating article according to claim 16, wherein a thickness of a peripheral wall of the hollow tubular segment is less than about 1.5 millimetres.

**24.** The aerosol-generating article according to claim 16, wherein an RTD of the aerosol-generating article is between about 30 millimetres H<sub>2</sub>O and about 90 millimetres H<sub>2</sub>O.

**25.** The aerosol-generating article according to claim 16, wherein a ratio between a weight of the hollow tubular segment and a volume of the cavity defined by the hollow tubular segment is less than 0.5 milligram/cubic millimetres.

**26.** The aerosol-generating article according to claim 16, wherein the aerosol-generating article has a ventilation level of at least about 20 percent.

**27.** The aerosol-generating article according to claim 16, wherein a distance between the ventilation zone and an upstream end of the hollow tubular segment is at least about 6 millimetres.

**28.** The aerosol-generating article according to claim 16, wherein a ratio between a distance between the ventilation zone and an upstream end of the hollow tubular segment and an equivalent internal diameter of the hollow tubular segment at the location of the ventilation zone is less than 4.

**29.** The aerosol-generating article according to claim 16, wherein an external diameter of the rod of aerosol-generating substrate is of between about 6 millimetres and about 8 millimetres.

**30.** The aerosol-generating article according to claim 16, wherein the ventilation zone further comprises two rows of perforations formed through the peripheral wall of the hollow tubular segment, the rows of perforations being longitudinally spaced apart from one another along the hollow tubular segment.

\* \* \* \* \*