



(12) **DEMANDE DE BREVET CANADIEN
CANADIAN PATENT APPLICATION**

(13) **A1**

(86) **Date de dépôt PCT/PCT Filing Date:** 2017/09/05
(87) **Date publication PCT/PCT Publication Date:** 2019/03/14
(85) **Entrée phase nationale/National Entry:** 2020/03/04
(86) **N° demande PCT/PCT Application No.:** JP 2017/031929
(87) **N° publication PCT/PCT Publication No.:** 2019/049202

(51) **Cl.Int./Int.Cl. F04D 29/58** (2006.01)

(71) **Demandeur/Applicant:**
IHI CORPORATION, JP

(72) **Inventeurs/Inventors:**
AKAMATSU, YOSUKE, JP;
KUWATA, GEN, JP;
YAMADA, KENTARO, JP

(74) **Agent:** MARKS & CLERK

(54) **Titre : MACHINE HYDRAULIQUE**

(54) **Title: FLUID MACHINE**

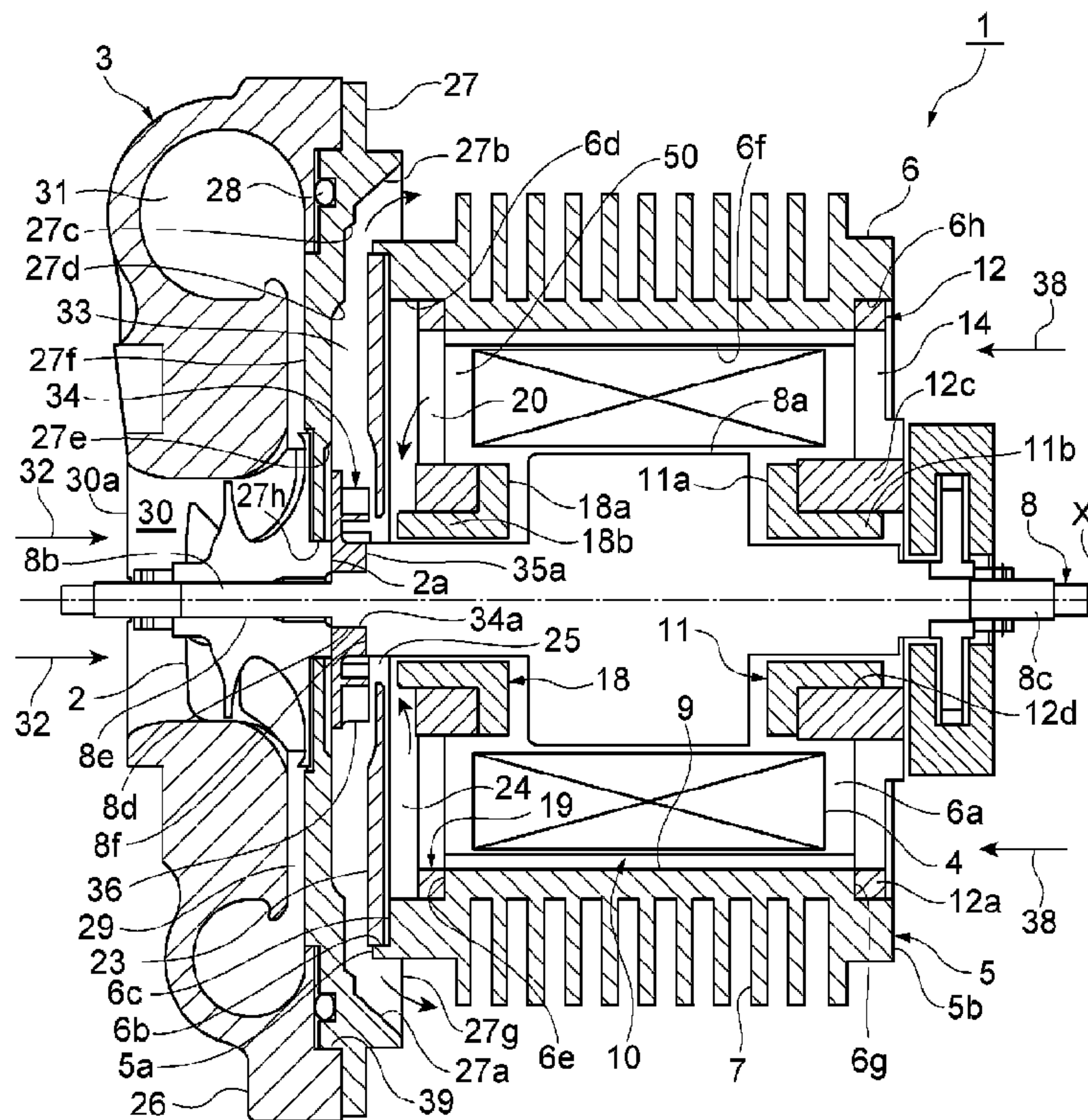

(57) **Abrégé/Abstract:**

A fluid machine comprising: a motor housing; a rotary shaft inserted into the motor housing; an impeller attached to an extension part of the rotary shaft; a facing section facing the motor housing at a first end in the axial direction; a first opening provided at the first end of the motor housing; a second opening provided at a second end of the motor housing; a housing internal flow path connecting the first opening and the second opening; an exhaust flow path provided between the motor housing and the facing section, and enabling the first opening to communicate with the outside air; and swirl vanes that are arranged between the first opening and the exhaust flow path and are attached to the rotary shaft, and are capable of rotating together with the rotary shaft.

ABSTRACT

This fluid machine includes a motor housing, a rotating shaft which is inserted through the motor housing, an impeller which is mounted on a protruding portion of the rotating shaft, a facing portion which faces the motor housing on a first end side in the axial direction, a first opening which is provided on the first end side of the motor housing, a second opening which is provided on a second end side of the motor housing, an in-housing passage which communicates the first opening with the second opening, an exhaust passage which is formed between the motor housing and the facing portion and communicates the first opening with external air, and a rotating blade which is disposed between the first opening and the exhaust passage, mounted on the rotating shaft and is rotatable with the rotating shaft.

DESCRIPTION

Title of Invention

FLUID MACHINE

Technical Field

5 [0001] The present disclosure relates to a fluid machine.

Background Art

[0002] A fluid machine such as a centrifugal blower or a compressor may include a motor. A motor includes a rotor and a coil which surrounds the rotor. The rotor of the motor is rotated by a rotating
10 magnetic field generated by the coil. An impeller is mounted on the rotor, and the fluid machine suctions air by rotating the impeller. When a rotating magnetic field is generated from the coil and the rotor rotates, the coil and the rotor generate heat, and a temperature of the motor may increase. When the temperature of the motor increases,
15 rotation efficiency of the motor decreases, and operation efficiency of the blower and the compressor decreases. In addition, since materials of components are limited, it is necessary to cool the motor.

[0003] Conventionally, as a means for cooling a motor, for example, there has been a method using a main flow or some of a main flow as
20 cooling air. In the conventional means, the main flow or some of the main flow is circulated around the motor in a process in which the main flow is suctioned and exhausted to the outside by rotating the impeller, and thus the motor is cooled.

[0004] For example, in a configuration described in Patent Literature 1,
25 air is taken in from a wind guide port of a fan case, and the air is guided to a blade portion of the fan. The air is delivered from a diffuser into

the inside of the motor case and passes around an insulating slot formed in an iron core of the rotor of the motor, or the like. The air cools the motor and is then exhausted to the outside of the motor case.

Citation List

5 Patent Literature

[0005] [Patent Literature 1] Japanese Unexamined Patent Publication No. 2000-236639

Summary of Invention

Technical Problem

10 [0006] In the conventional configuration, when the main flow or some of the main flow is used as cooling air, the main flow itself needs to have a temperature which can cool the motor, like external air. For example, when a temperature of the main flow is high, the main flow or some of the main flow cannot be used as cooling air.

15 [0007] The present disclosure describes a fluid machine having a structure which suctions external air as cooling air separately from a main flow.

Solution to Problem

20 [0008] A fluid machine according to an aspect of the present disclosure comprises a motor housing comprising a first end and a second end in an axial direction, a rotating shaft inserted through the motor housing and comprising a protruding portion protruding from the first end or the second end of the motor housing, an impeller mounted on the protruding portion of the rotating shaft, a facing portion facing the motor housing
25 on the first end side in the axial direction, a first opening provided on the first end side of the motor housing, a second opening provided on

the second end side of the motor housing and in communication with an external air, an internal passage (in-housing passage) formed in the motor housing and configured to fluidly couple the first opening with the second opening, an exhaust passage formed between the motor housing and the facing portion and communicating the first opening with the external air, and a swirling blade disposed between the first opening and the exhaust passage, mounted on the rotating shaft and rotatable with the rotating shaft.

Advantageous Effects of Invention

[0009] According to one aspect of the present disclosure, external air is suctioned into a motor housing as cooling air separately from a main flow.

Brief Description of Drawings

[0010] FIG. 1 is a cross-sectional view showing a fluid machine according to an embodiment of the present disclosure.

FIG. 2 is a diagram showing a motor housing in FIG. 1 from a second end side in an axial direction.

FIG. 3A is a front view showing a passage forming plate in FIG. 1, FIG. 3B is a cross-sectional view along line IIIB-IIIB in FIG. 3A, and FIG. 3C is an enlarged view of a main portion in FIG. 3B.

FIG. 4A is a front view showing a cooling fan in FIG. 1, and FIG. 4B is a cross-sectional view along line IVB-IVB in FIG. 4A.

FIG. 5 is a cross-sectional view showing a seal portion formed around a boss portion of an impeller in FIG. 1.

Description of Embodiments

[0011] A fluid machine according to an aspect of the present disclosure

comprises a motor housing comprising a first end and a second end in an axial direction, a rotating shaft inserted through the motor housing and comprising a protruding portion protruding from the first end or the second end of the motor housing, an impeller mounted on the protruding portion of the rotating shaft, a facing portion facing the motor housing on the first end side in the axial direction, a first opening provided on the first end side of the motor housing, a second opening provided on the second end side of the motor housing and communicating with an external air, an in-housing passage formed in the motor housing and communicating the first opening with the second opening, an exhaust passage formed between the motor housing and the facing portion and communicating the first opening with the external air, and a swirling blade disposed between the first opening and the exhaust passage, mounted on the rotating shaft and rotatable with the rotating shaft.

[0012] According to the fluid machine, the second opening, the in-housing passage, the first opening, and the exhaust passage are caused to communicate with each other. When the swirling blade rotates together with the rotating shaft, external air is suctioned from the second opening and flows through the above-described plurality of spaces. The motor can be cooled by the external air flowing in the motor housing. Thus, the external air is suctioned into the motor housing as cooling air separately from a main flow.

[0013] In some aspects, the impeller is mounted on the protruding portion protruding from the first end of the motor housing, the facing portion is disposed between the motor housing and the impeller, and a part of a back surface of the impeller is located on a motor housing side

of the facing portion. In this case, the facing portion defines a passage of the main flow generated by the impeller and a passage of the cooling air flowing in the motor housing. Since a part of the back surface of the impeller is located on the motor housing side of the facing portion,
5 downsizing in the axial direction is achieved.

[0014] In some aspects, a coil is fixed to an inner peripheral surface of the motor housing, and the motor housing comprises a groove which is formed on the inner peripheral surface and extends in the axial direction over a region in which the coil is provided. In this case, the cooling air
10 easily flows through the groove in the motor housing. The cooling air easily cools the coil.

[0015] In some aspects, the coil is spaced apart from the first end and the second end of the motor housing in the axial direction. In this case, external air is easily introduced into the groove in the motor housing.
15 As a result, cooling efficiency of the coil is improved.

[0016] In some aspects, the fluid machine further comprises a cooling fan comprising the swirling blade, the cooling fan comprises a boss portion through which the rotating shaft is inserted, the impeller is mounted on the protruding portion protruding from the first end of the
20 motor housing, the rotating shaft comprises a step portion facing the back surface of the impeller, and the cooling fan is mounted on the rotating shaft by the boss portion being sandwiched between the impeller and the step portion of the rotating shaft. In this case, the cooling fan can be mounted on the rotating shaft using the impeller and
25 the step portion provided on the rotating shaft. The configuration is simple, and space saving in the axial direction is possible.

[0017] In some aspects, the impeller is screwed into the protruding portion protruding from the first end of the motor housing, and the impeller presses the boss portion of the cooling fan on the back surface of the impeller. In this case, the cooling fan can be securely and easily
5 mounted on the rotating shaft by screwing the impeller into the rotating shaft.

[0018] In some aspects, the swirling blade comprises an inner end which is an end portion closer to the rotating shaft and an outer end which is an end portion farther from the rotating shaft, and extends
10 between the inner end and the outer end, and the outer end is located upstream from the inner end in a rotation direction of the rotating shaft. In this case, rotation of the swirling blade can create a good flow from the in-housing passage to the exhaust passage.

[0019] In some aspects, the first opening is located inward from the
15 outer end which is an end portion farther from the rotating shaft of the swirling blade. In this case, efficiency of suction of the cooling air from the inside of the motor housing due to the swirling blade is improved.

[0020] In some aspects, the fluid machine comprises a seal portion
20 formed on an inner diameter side of the facing portion and seals the motor housing and the impeller.

[0021] Hereinafter, an embodiment of the present disclosure will be described with reference to the drawings.

[0022] A fluid machine according to an embodiment of the present
25 disclosure will be described with reference to FIG. 1. In FIG. 1, the left side of the drawing is a tip end (a first end) side, and the right side of the

drawing is a base end (a second end) side. In the following description, the terms “tip end side” and “base end side” are used with reference to an axial direction.

5 [0023] In the embodiment, a centrifugal blower 1 will be described as an example of the fluid machine. The centrifugal blower 1 is, for example, an air-cooled electric blower which suctions air and sends it out at a predetermined pressure. The centrifugal blower 1 has an air suction port on the tip end side. The centrifugal blower 1 includes an impeller housing 3 in which an impeller 2 is accommodated, and a
10 motor housing 5 in which a coil 4 serving as a rotation drive portion for rotating the impeller 2 is accommodated.

[0024] The motor housing 5 includes a cylindrical motor housing main body portion 6. Radiation fins 7 are formed on an outer peripheral surface of the motor housing main body portion 6. The motor housing
15 main body portion 6 includes a first end 5a on the tip end side and a second end 5b on the base end side in the axial direction. The motor housing main body portion 6 has an insertion hole 6a which extends in the axial direction between the first end 5a and the second end 5b. A rotating shaft 8 made of, for example, stainless steel is inserted through
20 the motor housing main body portion 6.

[0025] The rotating shaft 8 is supported by a first bearing portion 18 provided in the vicinity of the first end 5a in the motor housing main body portion 6, and a second bearing portion 11 provided in the vicinity of the second end 5b in the motor housing main body portion 6. The
25 rotating shaft 8 is rotatable about a rotation axis X thereof.

[0026] The rotating shaft 8 has a first end portion 8b which protrudes

from the first end 5a of the motor housing main body portion 6 in the axial direction and a second end portion 8c which protrudes from the second end 5b of the motor housing main body portion 6 in the axial direction. The impeller 2 made of, for example, aluminum is mounted on the first end portion 8b which is a protruding portion of the rotating shaft 8. More specifically, a through hole is formed in the impeller 2 in the rotation axis X, and the first end portion 8b of the rotating shaft 8 is inserted through the through hole. For example, a male screw is formed on a peripheral surface of the first end portion 8b. A boss portion 2a which protrudes in a back surface direction is formed in the center of the impeller 2 on the base end side.

[0027] The motor housing main body portion 6 includes a first opening portion formed on the tip end side of the insertion hole 6a and a second opening portion formed on the base end side of the insertion hole 6a. The insertion hole 6a includes a first cylindrical portion 6b which extends from the first opening portion to the base end side, an annular first step portion 6c which reduces a diameter from the first cylindrical portion 6b, a second cylindrical portion 6d which extends from the first step portion 6c to the base end side, an annular second step portion 6e which reduces a diameter from the second cylindrical portion 6d, a third cylindrical portion 6f which extends from the second step portion 6e to the base end side, an annular third step portion 6g which increases a diameter from the third cylindrical portion 6f, and a fourth cylindrical portion 6h which extends from the third step portion 6g to the second opening portion. In other words, a diameter of the first cylindrical portion 6b is larger than that of the second cylindrical portion 6d.

Each of a diameter of the second cylindrical portion 6d and a diameter of the fourth cylindrical portion 6h is larger than that of the third cylindrical portion 6f. The third cylindrical portion 6f is the portion which has the smallest diameter in the insertion hole 6a of the motor housing main body portion 6, for example.

5 [0028] A rotor 8a is fixed to a central portion of the rotating shaft 8 in the axial direction. An outer diameter of the rotor 8a is larger than those of other portions of the rotating shaft 8. The rotor 8a includes a magnetic field generating source such as a permanent magnet. The rotor 8a is accommodated in the motor housing main body portion 6. That is, both ends of the rotor 8a in the axial direction are located between the first end 5a and the second end 5b of the motor housing main body portion 6.

10 [0029] The coil 4 is provided inside the motor housing main body portion 6. The coil 4 is, for example, an electromagnetic coil. The coil 4 is fixed to the third cylindrical portion 6f (the inner peripheral surface) of the motor housing main body portion 6. The coil 4 may include, for example, a conductive wire and a stator core which is an iron core on which the conductive wire is wound (neither is shown). The coil 4 is disposed around the rotor 8a and faces the rotor 8a with a gap therebetween. The motor 10 of the embodiment includes the stator including the coil 4 and the rotor 8a. The coil 4 can be energized via a wiring (not shown). A rotating magnetic field is generated between the coil 4 and the rotor 8a by energizing the coil 4, and the rotor 8a rotates.

25 [0030] An arrangement of the coil 4 will be described in more detail.

The coil 4 is spaced apart from the first end 5a and the second end 5b of the motor housing 5 in the axial direction. In other words, the coil 4 is shorter than a length between the first end 5a and the second end 5b in the axial direction. For example, the coil 4 is shorter than a length of the third cylindrical portion 6f in the axial direction. The coil 4 is accommodated in the third cylindrical portion 6f.

[0031] One or a plurality of grooves 9 are provided in the motor housing main body portion 6. When a direction in which the groove 9 extends is divided into an axial component and a circumferential component, the direction in which the groove 9 extends includes at least the axial component. The groove 9 is formed in, for example, the third cylindrical portion 6f and is connected to the second step portion 6e and the third step portion 6g. A bottom portion of the groove 9 (a portion farthest from the rotation axis X) is spaced apart from the coil 4 provided in the third cylindrical portion in a radial direction. The groove 9 defines a space which extends in the axial direction on the outer peripheral side of the coil 4.

[0032] In the embodiment, for example, a plurality of grooves 9 are formed. The plurality of grooves 9 are formed, for example, at a predetermined angular pitch. For example, six grooves 9 are formed at an angular pitch of 60°. The plurality of grooves 9 extend in the axial direction and may be parallel to each other. The one or the plurality of grooves 9 may extend spirally around the rotation axis X.

[0033] The one or more grooves 9 extend in the axial direction over a region in which the coil 4 is provided. In other words, the one or more grooves 9 is longer than a length of the coil 4 in the axial direction.

[0034] A portion of the rotating shaft 8 located on the tip end side from the rotor 8a is supported by the first bearing portion 18. A portion of the rotating shaft 8 located on the base end side from the rotor 8a is supported by the second bearing portion 11. That is, the rotating shaft 8 is rotatably supported by the first bearing portion 18 and the second bearing portion 11. The first bearing portion 18 includes a cylindrical support portion 18b which faces the rotating shaft 8 and supports the rotating shaft 8, and a flange portion 18a which is provided at a base end portion of the support portion 18b in the axial direction and protrudes outward in the radial direction. The second bearing portion 11 includes a cylindrical support portion 11b which faces the rotating shaft 8 and supports the rotating shaft 8, and a flange portion 11a which is provided at a tip end portion of the support portion 11b in the axial direction and protrudes outward in the radial direction.

[0035] A first bearing plate 19 is fitted to the second cylindrical portion 6d of the motor housing main body portion 6. The first bearing plate 19 is an annular member which is fitted to the first end 5a side of the motor housing main body portion 6 and holds the first bearing portion 18. A second bearing plate 12 is fitted to the fourth cylindrical portion 6h of the motor housing main body portion 6. The second bearing plate 12 is an annular member which is fitted to the second end 5b side of the motor housing main body portion 6 and holds the second bearing portion 11.

[0036] The second bearing plate 12 will be described with reference to FIGS. 1 and 2. The first bearing plate 19 may have the same structure as the second bearing plate 12. The first bearing plate 19 and the first

bearing portion 18 have, for example, a structure which is plane-symmetric with the second bearing plate 12 and the second bearing portion 11 with respect to a plane perpendicular to the rotation axis X. Hereinafter, only the second bearing plate 12 will be described, and detailed description of the first bearing plate 19 will be omitted.

[0037] As shown in FIG. 2, the second bearing plate 12 includes an annular rim portion 12a fitted to the fourth cylindrical portion 6h of the motor housing main body portion 6, a cylindrical hub portion 12c to which the second bearing portion 11 is fixed, and a plurality of spoke portions 12b which connect the rim portion 12a to the hub portion 12c. An insertion hole 12d which passes therethrough in the axial direction is formed in the hub portion 12c. The support portion 11b and the rotating shaft 8 supported by the support portion 11b are inserted through the insertion hole 12d.

[0038] The rim portion 12a of the second bearing plate 12 is fitted into the fourth cylindrical portion 6h of the motor housing main body portion 6 and is fixed to the third step portion 6g by a bolt or the like. The flange portion 11a of the second bearing portion 11 is fixed to the hub portion 12c of the second bearing plate 12 with a bolt or the like. Thus, the second bearing portion 11 is fixed to the hub 12c. The second bearing plate 12 restricts displacement of the second bearing portion 11 in the axial direction and the radial direction.

[0039] A plurality of intake ports (second openings) 14 which pass therethrough in the axial direction are provided on the outer peripheral side of the hub portion 12c of the second bearing plate 12. The intake

ports 14 are caused to communicate with a space of the motor housing main body portion 6 on the second end 5b side and an opening of the third cylindrical portion 6f on the base end side. A region between the rim portion 12a and the hub portion 12c which is not blocked by the spoke portions 12b is the intake ports 14.

[0040] The intake ports 14 are provided on the second end 5b side of the motor housing 5, caused to communicate with the external air and caused to communicate with the insertion hole 6a of the motor housing main body portion 6. In the second bearing plate 12, the plurality of intake ports 14 are formed at a predetermined angular pitch, for example. A filter (not shown) such as a dust filter may be provided in each of the intake ports 14.

[0041] On the other hand, the first bearing plate 19 also includes a rim portion, a hub portion, and a plurality of spoke portions. The rim portion of the first bearing plate 19 is fitted into the second cylindrical portion 6d of the motor housing main body portion 6 and is fixed to the second step portion 6e. The flange portion 18a of the first bearing portion 18 is fixed to the hub portion of the first bearing plate 19. The first bearing plate 19 restricts displacement of the first bearing portion 18 in the axial direction and the radial direction. A plurality of openings 20 are formed on the outer peripheral side of the hub portion, for example, at a predetermined angular pitch. The opening 20 is caused to communicate with the opening of the third cylindrical portion 6f on the tip end side. That is, the opening 20 is caused to communicate with the insertion hole 6a of the motor housing main body portion 6.

[0042] Next, a passage forming plate 23 provided at the first end 5a of the motor housing 5 will be described with reference to FIG. 1 and FIGS. 3A to 3C. As shown in FIG. 1 and FIGS. 3A, the annular passage forming plate 23 is fitted to the first cylindrical portion 6b of the motor housing main body portion 6. The passage forming plate 23 includes an annular outer peripheral plate portion 23a fitted to the first cylindrical portion 6b, and an inner peripheral plate portion 23b which is continuous with the inside of the outer peripheral plate portion 23a. A circular passage forming hole 23c which passes therethrough in the axial direction is formed at the center of the inner peripheral plate portion 23b.

[0043] As shown in FIGS. 1 and 3B, the inner peripheral plate portion 23b is thinner than the outer peripheral plate portion 23a in the axial direction. More specifically, the outer peripheral plate portion 23a has a constant thickness. The inner peripheral plate portion 23b is inclined from an inner peripheral end of the outer peripheral plate portion 23a toward the passage forming hole 23c and becomes thinner toward the passage forming hole 23c. A back surface of the passage forming plate 23 which faces the insertion hole 6a (faces the coil 4) is flat, but a surface of the passage forming plate 23 on the side opposite thereto has a concave portion 23d in the center (FIG. 3A and FIG. 3C). The passage forming plate 23 may protrude from the first opening portion of the motor housing main body portion 6 on the tip end side. That is, a part of the passage forming plate 23 in a thickness direction (the axial direction) may be fitted to the first cylindrical portion 6b.

[0044] The passage forming plate 23 is spaced apart from the first

bearing plate 19 in the axial direction. The passage forming plate 23 is also spaced apart from the first bearing portion 18 mounted on the first bearing plate 19. That is, a space 24 which extends in the radial direction is formed between the passage forming plate 23 and the first bearing plate 19. The opening 20 of the first bearing plate 19 communicates the insertion hole 6a of the motor housing main body portion 6 with the space 24.

[0045] The passage forming hole 23c provided in the passage forming plate 23 is formed around, for example, the rotation axis X. The passage forming hole 23c forms an exhaust port (a first opening) 25 provided on the first end 5a side of the motor housing 5. The passage forming hole 23c, that is, the exhaust port 25, is caused to communicate with the insertion hole 6a, the opening 20, and the space 24. The rotating shaft 8 is inserted through the passage forming hole 23c. In the embodiment, the exhaust port 25 is smaller than the intake port 14. A size of the exhaust port 25 may be appropriately changed.

[0046] The motor housing 5 includes the above-described motor housing main body portion 6, the second bearing plate 12, the first bearing plate 19, the passage forming plate 23, and the like. Additionally, an in-housing passage 50 which communicates the intake port 14 with the exhaust port 25 is formed in the motor housing 5. The in-housing passage 50 is formed in a gap between an inner wall surface of the motor housing main body portion 6, the coil 4, the rotating shaft 8, the second bearing plate 12, the second bearing portion 11, the first bearing plate 19, and the first bearing portion 18.

[0047] As shown in FIG 1, the impeller 2 mounted on the first end

portion 8b of the rotating shaft 8 is accommodated in the impeller housing 3. The impeller housing 3 includes an opening 30a which is an suction port provided on the tip end side in the axial direction, an inlet passage 30 which extends from the opening 30a to the base end side, a diffuser (an annular passage) 29 which is caused to communicate with the inlet passage 30 and formed to surround the impeller 2, a scroll 31 which is provided on an outer periphery of the diffuser 29 and caused to communicate with the diffuser 29, and an air outlet which is provided on the downstream side of the scroll 31. The impeller housing 3 includes, for example, an impeller housing main body portion 26 and a disc-shaped closing plate 27 mounted on the base end side of the impeller housing main body portion 26.

[0048] The above-described scroll 31 is formed in the impeller housing main body portion 26. The impeller housing main body portion 26 includes a circular opening 30a formed on the tip end side of the inlet passage 30, and a circular opening 39 which faces the opening 30a in the axial direction, is caused to communicate with the inlet passage 30, and is formed on the base end side.

[0049] The closing plate 27 is disposed on the back surface side of the impeller 2 (the rotor 8a side). The closing plate 27 is fitted in, for example, an opening 39 of the impeller housing main body portion 26 on the base end side. The closing plate 27 and the impeller housing main body portion 26 are fixed to each other by, for example, a bolt or the like. The closing plate 27 includes a first surface 27f provided on the impeller 2 side, and a second surface 27g provided on the motor housing 5 side. The first surface 27f and the impeller housing 3 define

the diffuser 29. An O-ring 28 is disposed on an outer periphery of an opening B of the impeller housing main body portion 26. The impeller housing main body portion 26 and the closing plate 27 sandwich the O-ring 28 to seal a passage of a main flow 32.

5 [0050] A concave surface (a facing portion) 27a which is concave toward the impeller 2 side is formed in the second surface 27g. That is, the concave surface 27a is disposed between the motor housing 5 and the impeller 2. In the axial direction, the first end 5a of the motor housing main body portion 6 is located on the impeller 2 side from the
10 second surface 27g of the closing plate 27. The first end 5a of the motor housing main body portion 6 enters a depression formed by the concave surface 27a. In other words, the concave surface 27a accommodates the first end 5a of the motor housing main body portion 6. The concave surface 27a faces the motor housing 5 on the first end
15 5a side in the axial direction.

[0051] The first end 5a of the motor housing main body portion 6 and the concave surface 27a are spaced apart from each other in the axial direction. An exhaust passage 33 which communicates the exhaust port 25 with the external air is formed between the first end 5a of the
20 motor housing main body portion 6 and the concave surface 27a.

[0052] A shape of the closing plate 27 will be described in more detail. A circular through hole 27h which passes therethrough in the axial direction is formed at the center of the closing plate 27. The boss portion 2a provided on the back surface of the impeller 2 is inserted
25 through the through hole 27h. That is, the boss 2a passes through the closing plate 27. A length of the boss portion 2a in the axial direction

is substantially equal to that of the through hole 27h of the closing plate 27 in the axial direction. In this way, a part of the back surface of the impeller 2 is located on the motor housing 5 side of the concave surface 27a.

5 [0053] A structure of the closing plate 27 around the impeller 2 will be described in more detail with reference to FIG. 5. As shown in FIG. 5, the closing plate 27 includes a seal portion 27k which faces the boss portion 2a of the impeller 2 on the inner diameter side. The seal portion 27k is formed at a peripheral edge portion of the through hole
10 27h. The seal portion 27k seals the motor housing main body portion 6 (the motor housing 5) and the impeller 2. The seal portion 27k has an annular concave portion 27n which is spaced outward from the boss portion 2a in the radial direction, and an annular convex portion 27m which is formed on both sides of the concave portion 27n in the axial
15 direction and protrudes from a bottom of the concave portion 27n toward the boss portion 2a of the impeller 2. That is, a groove is formed in an inner peripheral surface of the seal portion 27k in a circumferential direction. The groove of the seal portion 27k of the embodiment has a rectangular shape in the section in the axial direction.
20 The boss portion 2a of the impeller 2 and the convex portion 27m of the seal portion 27k are spaced apart from each other in the radial direction. The seal portion 27k forms a non-contact seal structure between the seal portion 27k and the boss portion 2a of the impeller 2.

[0054] As shown in FIG. 1, the concave surface 27a of the closing plate
25 27 includes a plurality of inclined portions. The concave surface 27a includes a first inclined portion 27b, a second inclined portion 27c, a

third inclined portion 27d, and a fourth inclined portion 27e from the outer peripheral side. An annular flat portion is formed between the inclined portions. The first inclined portion 27b and the second inclined portion 27c are located on the outer peripheral side of the first cylindrical portion 6b of the motor housing main body portion 6. The first inclined portion 27b extends from the tip end side (the impeller 2 side) of the first end 5a of the motor housing main body portion 6 to the base end side (the coil 4 side) in the axial direction. A step of the fourth inclined portion 27e is smaller than any of a step of the first inclined portion 27b, a step of the second inclined portion 27c, and a step of the third inclined portion 27d.

[0055] The concave surface 27a formed by the inclined portions and the flat portions faces the passage forming plate 23 provided at the first end 5a of the motor housing 5, and the exhaust passage 33 which extends in the radial direction is formed between the concave surface 27a and the passage forming plate 23. The exhaust passage 33 is caused to communicate with the exhaust port 25 at the center and to communicate with the external air at the outer peripheral end.

[0056] A screw seat portion (not shown) which protrudes toward the base end at a predetermined angular pitch is formed on the closing plate 27. The closing plate 27 and the motor housing main body portion 6 are fastened with a bolt or the like via the screw seat portion. Alternatively, the closing plate 27 and the motor housing main body portion 6 are fastened with a bolt or the like while the passage forming plate 23 is sandwiched between the screw seat portion and the motor housing main body portion 6. The impeller housing 3 and the motor

housing 5 are connected to each other with the closing plate 27 interposed therebetween. Then, the exhaust passage 33 is formed between the passage forming plate 23 and the closing plate 27.

5 [0057] A tip-side middle diameter portion 8d is formed on the tip side of the rotating shaft 8 from the passage forming plate 23. A cooling fan 34 made of, for example, aluminum is fitted and inserted into the tip-side middle diameter portion 8d. The cooling fan 34 is provided in the exhaust passage 33 to face the exhaust port 25.

10 [0058] As shown in FIGS. 1, 4A and 4B, the cooling fan 34 includes a boss portion 35a through which the tip-side middle diameter portion 8d of the rotating shaft 8 is inserted. An insertion hole 34a is formed in the boss portion 35a, and the tip-end middle diameter portion 8d is inserted through the insertion hole 34a. On the other hand, an annular step portion 8f which is continuous with the tip-side middle diameter portion 8d and of which a diameter is larger than that of the tip-side middle diameter portion 8d is formed on the rotating shaft 8. The step portion 8f is located between the motor housing main body portion 6 and the impeller 2 and faces the boss portion 2a of the impeller 2.

15 [0059] Further, a tip-side small diameter portion 8e is formed on the tip end side of the tip-side middle diameter portion 8d. The tip-side small-diameter portion 8e corresponds to the above-described first end portion 8b. The impeller 2 is fitted and inserted into the tip-side small diameter portion 8e. A fastening nut is screwed to the tip end side of the impeller 2. When the fastening nut is tightened, an axial force is generated, and the impeller 2 and the cooling fan 34 are mounted on the rotating shaft 8. In other words, a pressing force against the boss

20

25

portion 2a of the impeller 2 and the cooling fan 34 is generated from the fastening nut. That is, the boss portion 35a of the cooling fan 34 and the impeller 2 are held between the step portion 8f of the rotating shaft 8 and the fastening nut.

5 [0060] The impeller 2 presses the boss portion 35a of the cooling fan 34 with the boss portion 2a which is a part of the back surface. A gap is formed between the hub portion of the impeller 2 and the cooling fan 34, and the above-described closing plate 27 is located in the gap.

10 [0061] As shown in FIGS. 4A and 4B, the cooling fan 34 includes the boss portion 35a, an insertion hole 34a formed in the boss portion 35a, a disk portion 35 which extends radially outward from an end surface of the boss portion 35a on the tip side, and a plurality of blade portions (swirling blade, rotating blade) 36 which stand upright on the disk portion 35 and protrude toward the base end. That is, the blade portions 36 are mounted on the first end portion 8b of the rotating shaft 8 via the disk portion 35.

15 [0062] The blade portions 36 are disposed between the exhaust port 25 and the exhaust passage 33 and are rotatable with the rotating shaft 8. The boss portion 35a and the blade portions 36 are spaced apart from each other in the radial direction. The plurality of blade portions 36 are spaced apart from each other in the circumferential direction and are disposed, for example, at regular intervals. Each of the blade portions 36 includes an inner end 36b which is an end portion closer to the rotating shaft 8, and an outer end 36a which is an end portion farther from the rotating shaft 8, and extends between the inner end 36b and the outer end 36a. The outer end 36a is located upstream from the inner

20

25

end 36b in the rotation direction R of the rotating shaft 8. Each of the blade portions 36 extends from the inner end 36b toward the outer end 36a in a direction opposite to the rotation direction R. The blade portions 36 are formed, for example, up to the vicinity of an outer peripheral end of the disk portion 35.

[0063] As shown in FIG. 1, the boss portion 35a of the cooling fan 34 is located on the inner peripheral side from the passage forming plate 23. A diameter of the cooling fan 34 is larger than that of the exhaust port 25 of the passage forming plate 23. More specifically, the blade portion 36 extends to the outer peripheral side further than the passage forming hole 23c (refer to FIG. 3B) of the passage forming plate 23. In other words, the exhaust port 25 is located inside the outer end 36a of the blade portion 36. The outer end 36a of the blade portion 36 is provided within a range of the concave portion 23d of the passage forming plate 23 in the radial direction. A part of the blade portion 36 (a tip end portion farthest from the disk portion 35 in the axial direction) may enter the concave portion 23d of the passage forming plate 23. In other words, the concave portion 23d of the passage forming plate 23 may accommodate a part of the blade portion 36.

[0064] Next, an operation of the centrifugal blower 1 will be described. The centrifugal blower 1 can be used, for example, for blowing or suctioning air. When the centrifugal blower 1 is used for blowing air, an object to be blown is provided at an end of an outlet of the main flow 32 (that is, downstream). When the centrifugal blower 1 is used for suctioning air, an object to be suctioned is provided in front of (that is, upstream of) the suction port (the opening 30a) of the main flow 32.

[0065] When electric power is supplied to the coil 4 from a wiring (not shown), a rotating magnetic field is generated between the coil 4 and the rotor 8a of the rotating shaft 8, and the rotating shaft 8 rotates.

5 [0066] The impeller 2 rotates with the rotation of the rotating shaft 8, and the main flow 32 is suctioned into the impeller housing 3 by the rotation of the impeller 2. When the centrifugal blower 1 is used for suctioning air, the air is suctioned from a predetermined object to be suctioned. When the centrifugal blower 1 is used for blowing air, the main flow 32 suctioned into the impeller housing 3 is blown to a
10 predetermined object to be blown via the diffuser 29 and the scroll 31.

[0067] Further, the cooling fan 34 rotates with the rotation of the rotating shaft 8. The air inside the motor housing 5 is suctioned from the exhaust port 25 by the rotation of the cooling fan 34. The inside of the motor housing 5 has a negative pressure, and external air is
15 suctioned into the motor housing 5 through the intake port 14 as cooling air 38.

[0068] The cooling air 38 suctioned in from the intake port 14 flows between the in-housing passage 50 formed in the motor housing main body portion 6, the coil 4 and the rotor 8a. When the cooling air 38
20 flows through the in-housing passage 50, the cooling air 38 can also flow through the groove 9 formed in the inner peripheral surface of the motor housing main body portion 6.

[0069] The cooling air 38 flowing through the inside of the motor housing main body portion 6 reaches the space 24 via the opening 20.
25 The cooling air 38 which has reached the space 24 is deflected toward the center by the passage forming plate 23. The cooling air 38

deflected toward the center is exhausted from the exhaust port 25 to the outside of the motor housing 5.

5 [0070] The cooling air 38 exhausted from the exhaust port 25 and suctioned into the cooling fan 34 is exhausted outward in the radial direction, flows through the exhaust passage 33, is guided by the concave surface 27a including the plurality of inclined portions and is exhausted to the outside of the centrifugal blower 1.

10 [0071] During the operation of the centrifugal blower 1, although heat sources such as the coil 4 including the conductive wire and the stator core generate heat, the coil 4 is cooled by the cooling air 38 flowing in the motor housing main body portion 6 and further cooled by the radiation fins 7 which exchange heat with the external air. Heat sources other than the coil 4 include, for example, the rotor 8a including a permanent magnet, the first bearing portion 18 and the second bearing
15 portion 11, an air gap, and the like. The air gap is a flow of air which may be generated between the rotor 8a and the coil 4 in the rotation direction (the rotation direction R) of the rotor 8a. The air gap causes windage. In the embodiment, all of the above heat sources are cooled directly or indirectly.

20 [0072] According to the centrifugal blower 1 of the above-described embodiment, the intake port 14, the in-housing passage 50, the exhaust port 25, and the exhaust passage 33 are caused to communicate with each other. When the blade portions 36 rotate together with the rotating shaft 8, the external air is suctioned from the intake port 14 and
25 flows through the plurality of spaces above-mentioned. When the external air flows in the motor housing 5, the motor 10 including the

coil 4 and the rotor 8a can be cooled. Thus, the external air is suctioned into the motor housing 5 as the cooling air 38 separately from the main flow 32.

5 [0073] The concave surface 27a defines a passage of the main flow 32 generated by the impeller 2 and a passage of the cooling air 38 flowing in the motor housing 5. Since the boss portion 2a on the back surface of the impeller 2 is located on the motor housing 5 side of the concave surface 27a, downsizing in the axial direction is achieved.

10 [0074] The cooling air 38 easily flows in the motor housing 5 through the groove 9 formed in the inner peripheral surface of the motor housing 5. The cooling air 38 easily cools the heat sources such as the coil 4. For example, the cooling air 38 flowing in the groove 9 can directly cool the coil 4 and the stator core of the rotor 8a. The cooling air 38 can also indirectly cool the heat sources other than the coil 4 and the
15 stator core.

[0075] Since the coil 4 is spaced apart from the first end 5a and the second end 5b of the motor housing 5 in the axial direction, external air is easily introduced into the groove 9 in the motor housing 5. As a result, cooling efficiency of the coil 4 is improved.

20 [0076] The cooling fan 34 can be mounted on the rotating shaft 8 using the impeller 2 and the step portion 8f provided on the rotating shaft 8. The configuration is simple, and space saving in the axial direction is possible.

25 [0077] Since the blade portion 36 is inclined in the direction opposite to the rotation direction R with respect to the radial direction, the rotation of the blade portion 36 can generate a good flow from the in-housing

passage 50 to the exhaust passage 33.

[0078] Since the exhaust port 25 is located inward from the outer end 36a of the blade portion 36, the efficiency of suction of the cooling air 38 from the inside of the motor housing 5 due to the blade portion 36 is improved.

[0079] Further, the cooling fan 34 is provided on the rotating shaft 8 and rotates together with the impeller 2. Therefore, there is no need to separately provide a motor for rotating the cooling fan 34. Compared with a case in which a motor for suctioning external air as cooling air is separately provided, manufacturing cost of the centrifugal blower 1 can be reduced, and a size of the device can be reduced.

[0080] Further, since the passage forming plate 23 is provided between the impeller housing 3 and the motor housing 5, and the exhaust port 25 is provided between the passage forming plate 23 and the rotating shaft 8, and the cooling fan 34 is provided to face the exhaust port 25, the cooling air 38 can be exhausted outside the motor housing 5 without increasing a size of the cooling fan 34.

[0081] Further, the exhaust passage 33 is formed between the passage forming plate 23 and the closing plate 27 of the impeller housing 3, and the passages of the cooling air 38 suctioned and exhausted by the cooling fan 34 are separated by the passage forming plate 23. Therefore, interference between the cooling air 38 suctioned in by the cooling fan 34 and the cooling air 38 exhausted is curbed, and exhaust efficiency of the cooling air 38 can be improved.

[0082] Further, the cooling air 38 is exhausted outside the centrifugal blower 1 by the cooling fan 34 and the exhaust passage 33. Even

when a high-temperature main flow 32 is introduced from the impeller housing 3, introduction of the main flow 32 into the motor housing 5 can be curbed.

5 [0083] Although the embodiment of the present disclosure have been described above, the present invention is not limited to the above-described embodiment.

10 [0084] For example, a female screw may be formed on the peripheral surface of the through hole of impeller 2. Then, the impeller 2 may be screwed into the first end portion 8b of the rotating shaft 8 and may press the boss portion 35a of the cooling fan 34 by the boss portion 2a which is a part of the back surface of the impeller 2. According to such a configuration, the cooling fan 34 can be securely and easily mounted on the rotating shaft 8.

15 [0085] The facing portion which faces the motor housing 5 on the first end 5a side in the axial direction is not limited to the case in which the facing portion is formed by the closing plate 27 which is a single member. The facing portion may be formed by a portion integrally formed with the impeller housing 3 or may be formed by a portion integrally formed with the motor housing 5. A member such as the closing plate 27 may be mounted on the motor housing 5. The concave surface may not be formed, and a flat facing portion may be provided. The seal portion formed on the closing plate 27 is not limited to the non-contact type seal portion 27k as in the above-described embodiment. For example, when a rotation speed of the impeller 2 is low, the seal portion of the closing plate 27 may form a contact-type seal structure which seals the impeller 2 by being in

20

25

contact with the boss portion 2a of the impeller 2. The seal portion of the closing plate 27 may be omitted.

5 [0086] In the above-described embodiment, although an example of a centrifugal fan in which the cooling fan 34 suctions the cooling air 38 from the center and exhausts the cooling air 38 in an outer diameter direction has been described, the present invention is not limited thereto. The cooling fan 34 may be an axial fan provided in the exhaust port 25 or may be another type of fan. The swirling blade (truning vane) may be directly mounted on the rotating shaft 8.

10 [0087] In the above-described embodiment, although the example in which the impeller 2 is mounted on the first end portion 8b of the rotating shaft 8 has been described, the impeller 2 may be mounted on the second end portion 8c of the rotating shaft 8. In this case, the first opening, the exhaust passage, and the swirling blade are provided on the
15 first end 5a side of the motor housing 5, but the impeller 2 is provided on the second end 5b side opposite thereto. For example, the impeller housing main body portion 26 and the closing plate 27 are separate bodies. For example, the closing plate 27 is provided on the first end 5a side of the motor housing 5, and the impeller housing main body
20 portion 26 and the impeller 2 are provided on the second end 5b side of the motor housing 5.

[0088] In the above-described embodiment, the cooling structure using the centrifugal blower 1 as an example has been described, but the present invention is also applicable to a centrifugal compressor. The
25 fluid machine to which the present invention is applied may be an axial flow type blower or compressor.

Industrial Applicability

[0089] According to some aspects of the present disclosure, external air is suctioned into the motor housing 5 as cooling air separately from a main flow.

5 Reference Signs List

- [0090] 1 Centrifugal blower (fluid machine)
- 2 Impeller
 - 3 Impeller housing
 - 4 Coil
 - 10 5 Motor housing
 - 5a First end
 - 5b Second end
 - 8 Rotating shaft
 - 8a Rotor
 - 15 9 Groove
 - 8b First end portion (end portion)
 - 8f Step portion
 - 10 Motor
 - 14 Intake port (second opening)
 - 20 20 Opening
 - 23 Passage forming plate
 - 24 Space
 - 25 Exhaust port (First opening)
 - 27 Closing plate
 - 25 27a Closing surface (facing portion)
 - 27k Seal portion

- 32 Main flow
- 33 Exhaust passage
- 34 Cooling fan
- 35a Boss portion
- 5 36 Blade portion (swirling blade, turning vane)
- 36a Outer end
- 36b Inner end
- 38 Cooling air
- 50 In-housing passage
- 10 R Rotation direction

CLAIMS

1. A fluid machine comprising:
 - a motor housing comprising a first end and a second end in an axial direction;
 - 5 a rotating shaft inserted through the motor housing and comprising a protruding portion that protrudes from the first end or the second end of the motor housing;
 - an impeller mounted on the protruding portion of the rotating shaft;
 - 10 a facing portion that faces the motor housing on the first end side in the axial direction;
 - a first opening located at the first end side of the motor housing;
 - a second opening located at the second end side of the motor housing and in communication with external air;
 - 15 an in-housing passage formed in the motor housing and communicating the first opening with the second opening;
 - an exhaust passage formed between the motor housing and the facing portion and communicating the first opening with the external air; and
 - 20 a rotating blade located between the first opening and the exhaust passage, mounted on the rotating shaft and rotatable with the rotating shaft.
2. The fluid machine according to claim 1,
 - 25 wherein the impeller is mounted on the protruding portion protruding from the first end of the motor housing,

wherein the facing portion is located between the motor housing and the impeller, and

wherein a part of a back surface of the impeller is located on a motor housing side of the facing portion.

5

3. The fluid machine according to claim 1 or 2,

wherein a coil is fixed to an inner peripheral surface of the motor housing, and

10 wherein the motor housing comprises a groove which is formed on the inner peripheral surface and extends in the axial direction over a region in which the coil is provided.

4. The fluid machine according to claim 3, wherein the coil is spaced apart from the first end and the second end of the motor housing
15 in the axial direction.

5. The fluid machine according to any one of claims 1 to 4, further comprising a cooling fan that includes the rotating blade,

20 wherein the cooling fan comprises a boss portion through which the rotating shaft is inserted,

wherein the impeller is mounted on the protruding portion that protrudes from the first end of the motor housing,

wherein the rotating shaft comprises a step portion that faces the back surface of the impeller, and

25 wherein the cooling fan is mounted on the rotating shaft by the boss portion that is sandwiched between the impeller and the step

portion of the rotating shaft.

6. The fluid machine according to claim 5,
wherein the impeller is screwed into the protruding portion
5 protruding from the first end of the motor housing, and
wherein the impeller presses the boss portion of the cooling fan
on the back surface of the impeller.
7. The fluid machine according to any one of claims 1 to 6,
10 wherein the rotating blade comprises an inner end which is an
end portion closer to the rotating shaft and an outer end which is an end
portion farther from the rotating shaft, and extends between the inner
end and the outer end, and
wherein the outer end is located upstream from the inner end in
15 a rotation direction of the rotating shaft.
8. The fluid machine according to any one of claims 1 to 7,
wherein the first opening is located inward from the outer end which is
an end portion farther from the rotating shaft of the rotating blade.
20
9. The fluid machine according to claim 2, comprising a seal
portion formed on an inner diameter side of the facing portion and seals
the motor housing and the impeller.

Fig.1

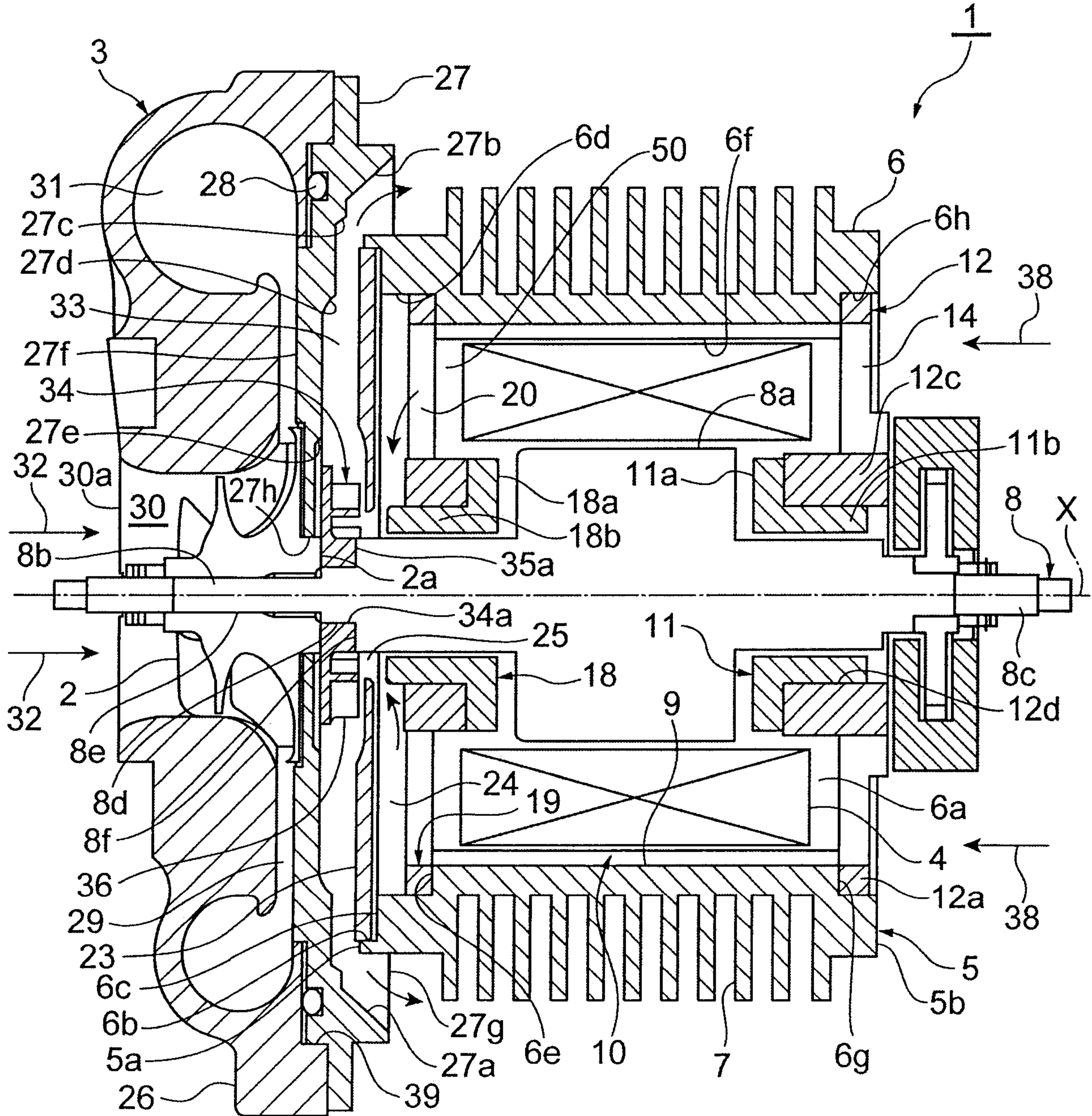

Fig.2

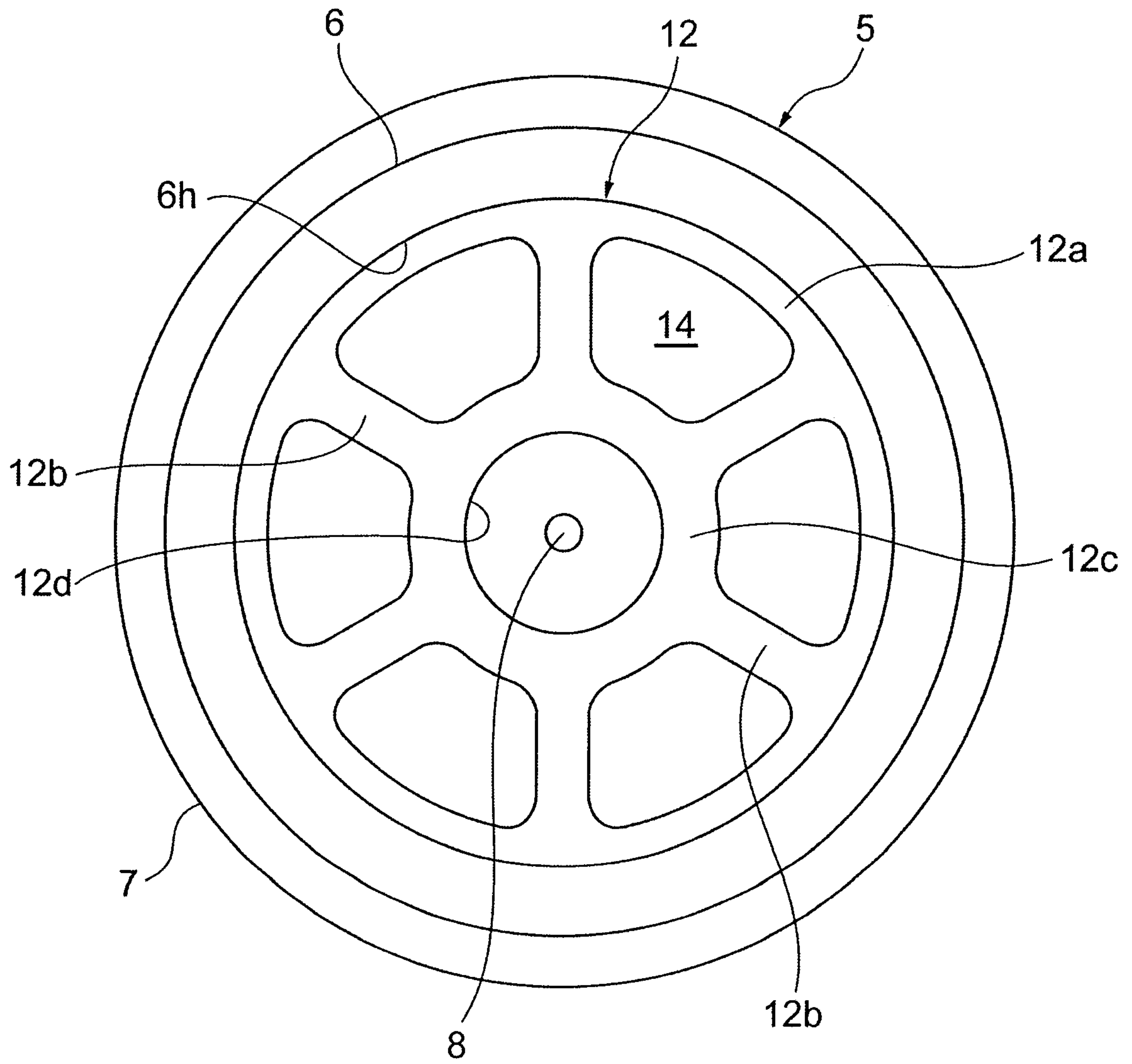

Fig.3A

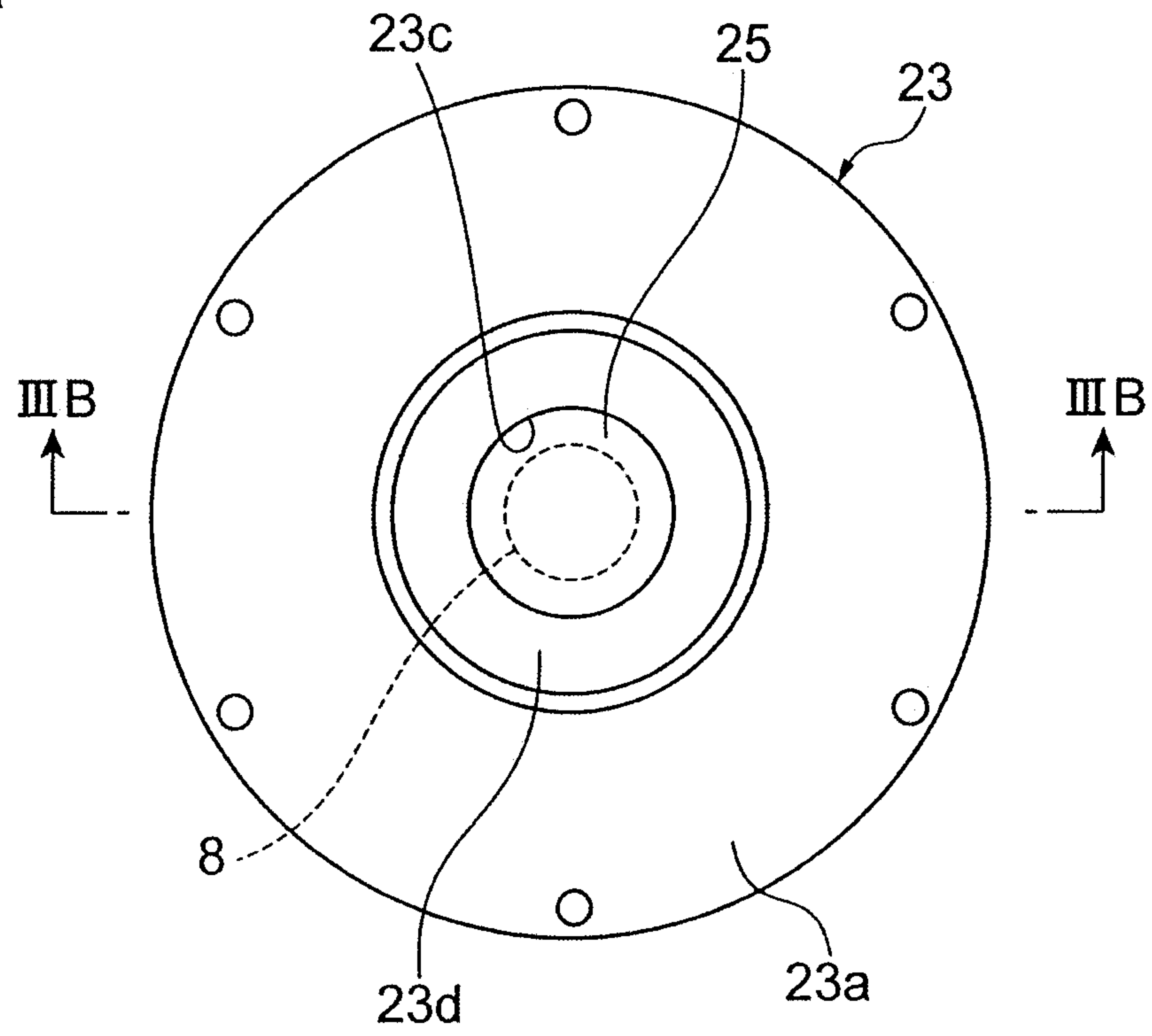

Fig.3B

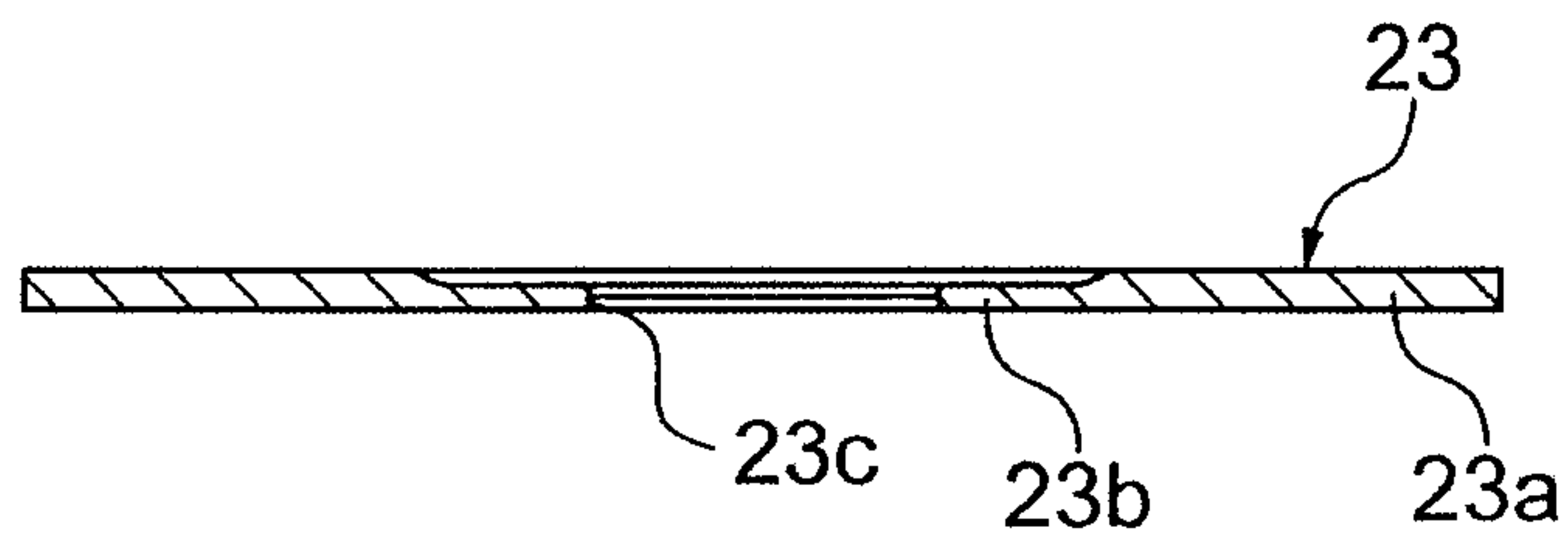

Fig.3C

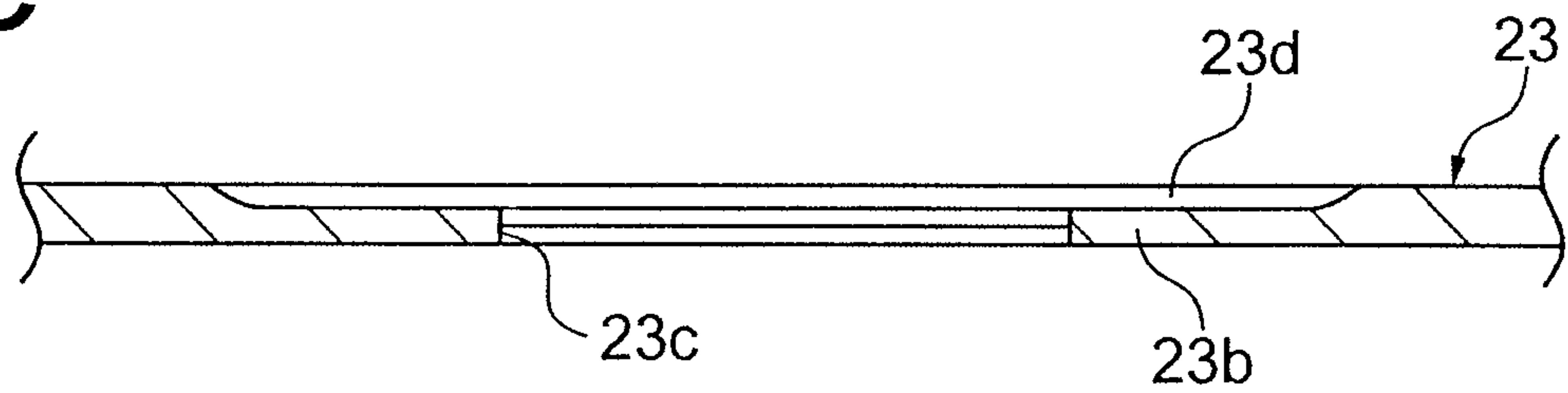

Fig.4A

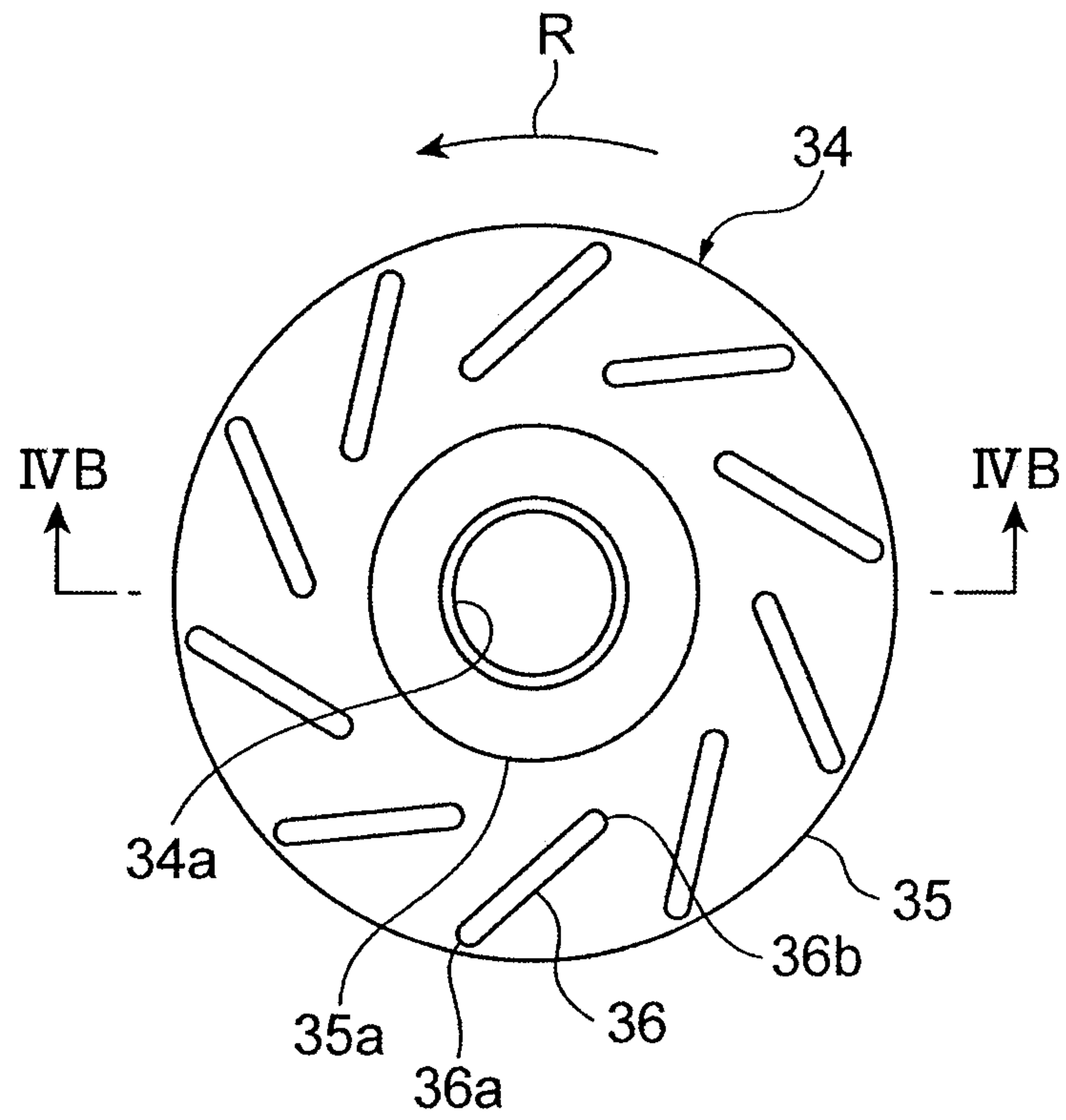

Fig.4B

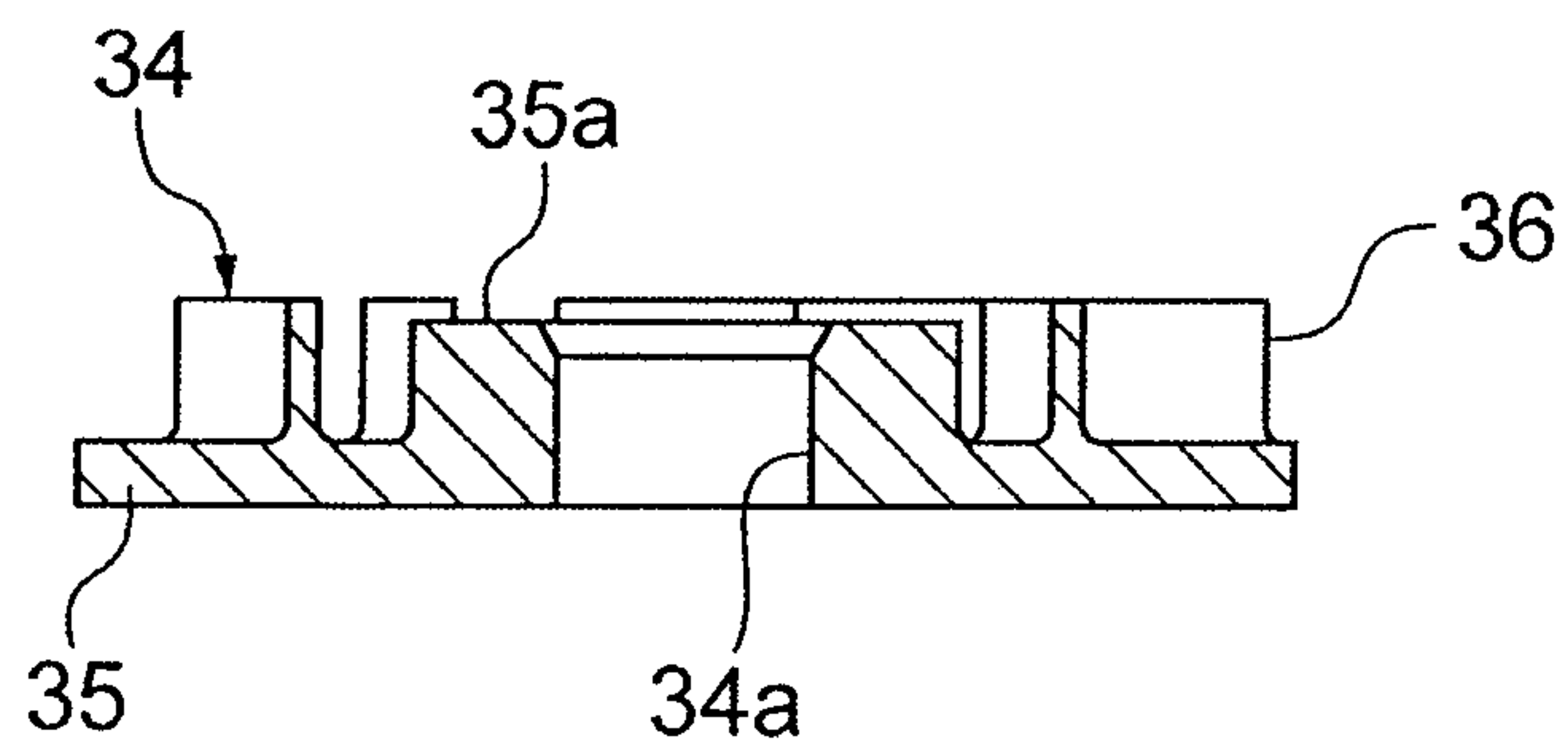

Fig. 5

