

(19) World Intellectual Property Organization
International Bureau



(43) International Publication Date
3 June 2010 (03.06.2010)

PCT

(10) International Publication Number
WO 2010/062094 A2

- (51) **International Patent Classification:**
H04B 10/10 (2006.01) H04B 10/00 (2006.01)
H04B 10/04 (2006.01)
- (21) **International Application Number:**
PCT/KR2009/006923
- (22) **International Filing Date:**
24 November 2009 (24.11.2009)
- (25) **Filing Language:** English
- (26) **Publication Language:** English
- (30) **Priority Data:**
2008-298941 25 November 2008 (25.11.2008) JP
- (71) **Applicant (for all designated States except US):** **SAM-SUNG ELECTRONICS CO., LTD.** [KR/KR]; 416, Maetan-dong, Yeongtong-gu, Suwon-si, Gyeonggi-do 442-742 (KR).
- (72) **Inventor; and**
- (75) **Inventor/Applicant (for US only):** **YOKOI, Atsuya** [JP/JP]; c/o Samsung Yokohama Research Institute, 2-7 Sugasawa-cho, Tsurumi-ku, Yokohama-shi, Kanagawa 2300027 (JP).
- (74) **Agent:** **LEE, Keon-Joo;** Mihwa Bldg., 110-2 Myongryun-dong 4-ga, Chongro-gu, Seoul 110-524 (KR).

- (81) **Designated States (unless otherwise indicated, for every kind of national protection available):** AE, AG, AL, AM, AO, AT, AU, AZ, BA, BB, BG, BH, BR, BW, BY, BZ, CA, CH, CL, CN, CO, CR, CU, CZ, DE, DK, DM, DO, DZ, EC, EE, EG, ES, FI, GB, GD, GE, GH, GM, GT, HN, HR, HU, ID, IL, IN, IS, KE, KG, KM, KN, KP, KR, KZ, LA, LC, LK, LR, LS, LT, LU, LY, MA, MD, ME, MG, MK, MN, MW, MX, MY, MZ, NA, NG, NI, NO, NZ, OM, PE, PG, PH, PL, PT, RO, RS, RU, SC, SD, SE, SG, SK, SL, SM, ST, SV, SY, TJ, TM, TN, TR, TT, TZ, UA, UG, US, UZ, VC, VN, ZA, ZM, ZW.
- (84) **Designated States (unless otherwise indicated, for every kind of regional protection available):** ARIPO (BW, GH, GM, KE, LS, MW, MZ, NA, SD, SL, SZ, TZ, UG, ZM, ZW), Eurasian (AM, AZ, BY, KG, KZ, MD, RU, TJ, TM), European (AT, BE, BG, CH, CY, CZ, DE, DK, EE, ES, FI, FR, GB, GR, HR, HU, IE, IS, IT, LT, LU, LV, MC, MK, MT, NL, NO, PL, PT, RO, SE, SI, SK, SM, TR), OAPI (BF, BJ, CF, CG, CI, CM, GA, GN, GQ, GW, ML, MR, NE, SN, TD, TG).

Published:
— without international search report and to be republished upon receipt of that report (Rule 48.2(g))

(54) **Title:** VISIBLE RAY COMMUNICATION SYSTEM, TRANSMISSION APPARATUS, AND SIGNAL TRANSMISSION METHOD

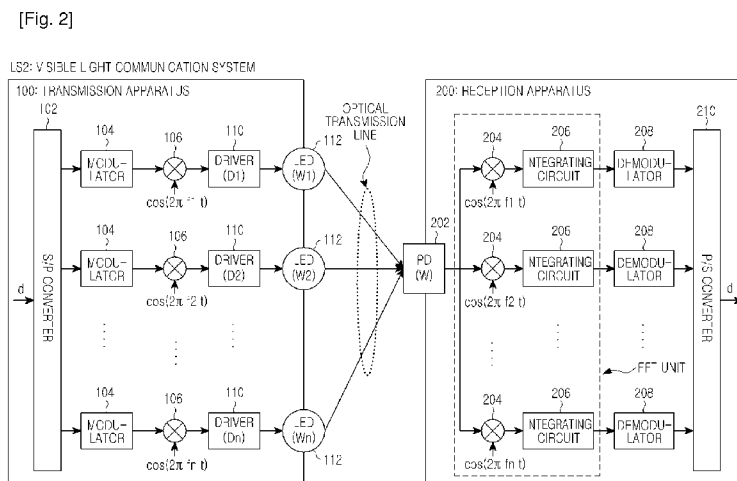

(57) **Abstract:** Disclosed is a visible ray communication system including a transmission apparatus and a reception apparatus, wherein the transmission apparatus includes: a plurality of light emitting devices; an S/P converter for serial-to-parallel converting transmission data, thereby generating N data streams; a modulator for modulating the generated N data streams for respective carriers with a predetermined number of dimensions, thereby generating N modulated signals; a carrier signal multiplier for multiplying the generated N modulated signals by orthogonal N carrier signals, respectively, thereby generating N transmission signals; and a light emitting control unit for illuminating the plurality of light emitting devices according to the generated N transmission signals.

WO 2010/062094 A2

Description

Title of Invention: VISIBLE RAY COMMUNICATION SYSTEM, TRANSMISSION APPARATUS, AND SIGNAL TRANSMISSION METHOD

Technical Field

- [1] The present invention relates to a visible ray communication system, a transmission apparatus, and a signal transmission method.

Background Art

- [2] An optical communication technology using the light in a visible ray region has been recently greatly spotlighted. Especially, as an illuminating device using a luminous element, such as an LED (Light Emitting Diode), has rapidly come into wide use, development of a technology for achieving higher speed data communication with high convenience by utilizing an infrastructure, such as an interior/exterior illuminating device, has been carried out.
- [3] As a light emitting means used for high speed optical data communication, an LED is the most powerful candidate in consideration of an influence on a human body or medical appliances. Meanwhile, a semiconductor light emitting device with a higher speed response performance, such as a laser diode (LD) or a super luminescent diode (SLD), is proposed as a candidate. The data transmission speed in the optical communication depends on a response speed of a light emitting device. Due to this reason, such a light emitting device with a higher speed response performance is spotlighted.
- [4] Also, in order to further improve the data transmission speed, a technology for stably transmitting lots of data during one signal emitted from a light emitting device is required. For example, as such an optical communication technology, Japanese Patent Laid-Open Publication HEI 2008-252444 discloses a technology of removing spatial interference by allocating a time axis of an OFDM (Orthogonal Frequency-Division Multiplexing) signal in a spatial direction.

Disclosure of Invention

Technical Problem

- [5] When OFDM is used, it is possible to improve the frequency use efficiency and the endurance against multi-path. Thus, the OFDM is widely used in a wireless communication system (e.g., a wireless LAN) or a wired communication system (e.g., ADSL). In visible ray communication, the communication quality is expected to be improved by the application of the OFDM. However, in the OFDM, there is a problem in that a PAPR (Peak to Average Power Ratio) is increased. In other words, a large dynamic

range is required in a transmitter and a receiver.

[6] Accordingly, when the OFDM is applied to the visible ray communication, a very large current flows in an LED, as a transmission means of the visible ray communication. For example, in an LED, a current ranging from several hundred mA to several A flows. For this reason, it is required to provide a drive circuit capable of covering a signal with a very wide dynamic range in a transmission-side. However, in general, an LED is for emitting light with a predetermined quantity, and thus is in actuality not appropriate for handling such a wide dynamic range signal because it requires a special element.

[7] Accordingly, the present invention has been made to solve the above-mentioned problems occurring in the prior art, and the present invention provides a visible ray communication system, a transmission apparatus, and a signal transmission method, which are novel and improved in that the performance requirement for a high dynamic range is not imposed on a light emitting means, the improvement of communication quality, similar to that achieved by OFDM, can be achieved, and more data can be transmitted with a predetermined number of multiplexing processes.

Solution to Problem

[8] In accordance with an aspect of the present invention, there is provided a visible ray communication system including a transmission apparatus and a reception apparatus, wherein the transmission apparatus includes: a plurality of light emitting devices; a serial-to-parallel (S/P) converter for serial-to-parallel converting transmission data, thereby generating N data streams; a modulator for modulating the N data streams generated by the S/P converter for respective carriers with a predetermined number of dimensions, thereby generating N modulated signals; a carrier signal multiplier for multiplying the N modulated signals generated by the modulator by N carrier signals orthogonal to the N modulated signals, respectively, thereby generating N transmission signals; and a light emitting control unit for illuminating the plurality of light emitting devices according to the N transmission signals generated by the carrier signal multiplier, and the reception apparatus includes: a light receiving device for receiving lights, the lights being emitted from the plurality of light emitting devices of the transmission apparatus and spatially multiplexed in a transmission line, thereby outputting reception signals according to corresponding reception intensities; an FFT unit for performing FFT on the reception signals output from the light receiving device by using the N carrier signals, thereby extracting the N modulated signals of the respective carriers; and a demodulator for demodulating each of the modulated signals extracted from the FFT unit.

[9] Through the application of the above described configuration, it is possible to

achieve the improvement of communication performance, similar to that achieved by OFDM. For example, it is possible to improve the frequency use efficiency and the endurance by using a conventional infrastructure.

[10] Also, when a number N of the light emitting devices is greater than a number n of the carrier signals ($N > n$), the light emitting control unit may illuminate multiple devices of the light emitting devices at once based on one of the transmission signals. Meanwhile, when a number N of the light emitting devices is less than a number n of the carrier signals ($N < n$), the light emitting control unit may add M ($2 \leq M < n$) signals of the transmission signals, and illuminate the light emitting devices based on the transmission signals obtained through the addition.

[11] Also, the reception apparatus may include, as the light receiving device, an image sensor for detecting intensity of each of the lights emitted from the plurality of light emitting devices, and outputting a reception signal corresponding to each of the light emitting devices. Through this configuration, since the intensity of the light generated from each light emitting device can be detected, it is possible to reduce the dynamic range performance requirement imposed on a light receiving means.

[12] Also, the transmission apparatus may include the plurality of light emitting devices radiating differently colored lights. In this case, the reception apparatus includes a plurality of light receiving devices for receiving the differently colored lights, and outputting reception signals based on the corresponding reception intensities. Through this configuration, since the intensity of the light generated from each light emitting device can be detected, it is possible to reduce the dynamic range performance requirement imposed on a light receiving means. Also, when the configuration is applied, the influence of a color interference caused by the optical frequency property of a light emitting device and a light receiving device can be removed because the signal of each carrier frequency has orthogonality.

[13] In accordance with another aspect of the present invention, there is provided a transmission apparatus including: a plurality of light emitting devices; an S/P converter for serial-to-parallel converting transmission data, thereby generating N data streams; a modulator for modulating the N data streams generated by the S/P converter for respective carriers with a predetermined number of dimensions, thereby generating N modulated signals; a carrier signal multiplier for multiplying the N modulated signals generated by the modulator by N carrier signals orthogonal to the N modulated signals, respectively, thereby generating N transmission signals; and a light emitting control unit for illuminating the plurality of light emitting devices according to the N transmission signals generated by the carrier signal multiplier.

[14] Through the application of the above described configuration, it is possible to achieve the improvement of communication performance, similar to that achieved by

OFDM. For example, it is possible to improve the frequency use efficiency and the endurance against multi-path. Also, a transmission signal generated by multiplication of each carrier signal is not multiplexed within a transmission apparatus, and is directly transmitted by each light emitting device. Accordingly, compared to the case where N transmission signals are multiplexed and then transmitted, it is possible to control the dynamic range required for a light emitting device, and a light emitting control unit to be low. As a result, for the light emitting device or the light emitting control unit, a relatively inexpensive LED (or an LED driving circuit) may be used, and a manufacturing cost for a transmission apparatus can be reduced. In general, an LED (or an LED driving circuit) used for a general illuminating device can hardly satisfy the performance requirement for a high dynamic range. However, in the above described configuration of a transmission apparatus, since the performance requirement for a dynamic range is controlled to be low, it is possible to use a conventional infrastructure.

[15] In accordance with a further aspect of the present invention, there is provided a signal transmission method including the steps of: serial-to-parallel (S/P) converting transmission data by a transmission apparatus including a plurality of light emitting devices, thereby generating N data streams; modulating the generated N data streams for respective carriers with a predetermined number of dimensions, by the transmission apparatus, thereby generating N modulated signals; multiplying the generated N modulated signals by N carrier signals orthogonal to the N modulated signals, respectively, by the transmission apparatus, thereby generating N transmission signals; illuminating the plurality of light emitting devices according to the generated N transmission signals by the transmission apparatus; performing, by a reception apparatus including a light receiving device for receiving lights emitted from the plurality of light emitting devices of the transmission apparatus and outputting reception signals according to corresponding reception intensities, the lights being spatially multiplexed in a transmission line, FFT on the reception signals output from the light receiving device by using the N carrier signals, thereby extracting the N modulated signals of the respective carriers; and demodulating each of the extracted modulated signals.

[16] Through the application of the above described method, it is possible to achieve the improvement of communication performance, similar to that achieved by OFDM. For example, it is possible to improve the frequency use efficiency and the endurance against multi-path. Also, a transmission signal generated by multiplication of each carrier signal is not multiplexed within a transmission apparatus, and is directly transmitted by each light emitting device. Accordingly, compared to the case where N transmission signals are multiplexed and then transmitted, it is possible to control the

dynamic range required for a light emitting device, and a light emitting control unit to be low. As a result, for the light emitting device or the light emitting control unit, a relatively inexpensive LED (or an LED driving circuit) may be used, and a manufacturing cost for a transmission apparatus can be reduced. In general, an LED (or an LED driving circuit) used for a general illuminating device can hardly satisfy the performance requirement for a high dynamic range. However, in the above described configuration of a visible ray communication system, since the performance requirement for a dynamic range is controlled to be low, it is possible to achieve the system configuration by using a conventional infrastructure.

[17] In accordance with a still further aspect of the present invention, there is provided a signal transmission method by a transmission apparatus including a plurality of light emitting devices, the method including the steps of: serial-to-parallel converting transmission data, thereby generating N data streams; modulating the generated N data streams for respective carriers with a predetermined number of dimensions, thereby generating N modulated signals; multiplying the generated N modulated signals by N carrier signals orthogonal to the N modulated signals, respectively, thereby generating N transmission signals; and illuminating the plurality of light emitting devices according to the generated N transmission signals.

[18] Through the application of the above described method, it is possible to achieve the improvement of communication performance, similar to that achieved by OFDM. For example, it is possible to improve the frequency use efficiency and the endurance against multi-path. Also, a transmission signal generated by multiplication of each carrier signal is not multiplexed within a transmission apparatus, and is directly transmitted by each light emitting device. Accordingly, compared to the case where N transmission signals are multiplexed and then transmitted, it is possible to control the dynamic range required for a light emitting device, and a light emitting control unit to be low. As a result, for the light emitting device or the light emitting control unit, a relatively inexpensive LED (or an LED driving circuit) may be used, and a manufacturing cost for a transmission apparatus can be reduced. In general, an LED (or an LED driving circuit) used for a general illuminating device can hardly satisfy the performance requirement for a high dynamic range. However, in the above described configuration of a transmission apparatus, since the performance requirement for a dynamic range is controlled to be low, it is possible to use a conventional infrastructure.

Advantageous Effects of Invention

[19] In the above description, as a light emitting means, an LED is used. However, besides the LED, various devices, such as a semiconductor light emitting device (e.g.,

LD, SLD), a fluorescent lamp, a Braun tube (CRT), a display device, a plasma display device (PDP), an organic electroluminescent (EL) display device, a liquid crystal monitor (LCD) device, may be used as the light emitting means.

- [20] As described above, according to the present invention, it is possible to achieve the improvement of communication quality, similar to that achieved by OFDM, without imposing the performance requirement for a high dynamic range upon a light emitting means. As a result, it is possible to achieve a transmission apparatus, and a visible ray communication system which are convenient and inexpensive, and have a high communication performance, similar to that achieved by OFDM.

Brief Description of Drawings

- [21] FIG. 1 is an explanatory view illustrating an example of the configuration of a visible ray communication system using OFDM;
- [22] FIG. 2 is an explanatory view illustrating an example of the configuration of a visible ray communication system according to one embodiment of the present invention;
- [23] FIG. 3 is an explanatory view illustrating an example of the configuration of a visible ray communication system according to a modified embodiment of FIG. 2;
- [24] FIG. 4 is an explanatory view illustrating an example of the configuration of a visible ray communication system according to a modified embodiment of FIG. 2;
- [25] FIG. 5 is an explanatory view illustrating an example of the configuration of a visible ray communication system according to a modified embodiment of FIG. 2; and
- [26] FIG. 6 is an explanatory view illustrating an example of the configuration of a visible ray communication system according to a modified embodiment of FIG. 2.

Mode for the Invention

- [27] Hereinafter, exemplary embodiments of the present invention will be described in detail with reference to the accompanying drawings. Here, in this specification and drawings, repeated description of constituents having substantially the same functional configurations will be omitted by allotting the same reference numerals.
- [28] [The order of this detailed description]
- [29] Hereinafter, the sequence of explanation on embodiments of the present invention, which will be described later, is as follows. First, the configuration of an OFDM-using visible ray communication system LS1 will be described with reference to FIG. 1. Especially, some problems caused by the application of OFDM in a visible ray communication system will be described. Then, the configuration of a visible ray communication system LS2 according to an embodiment of the present invention will be described with reference to FIG. 2. Then, visible ray communication systems LS3 and LS4 according to modified embodiments of the embodiment will be described with reference to FIGs. 3 and 4.

- [30] [Summary of problems to be solved]
- [31] Hereinafter, before a detailed description on the technology of one embodiment of the present invention is given, some problems to be solved by the embodiment will be summarized.
- [32] (Configuration of a visible ray communication system LS1)
- [33] First, the configuration of a visible ray communication system LS1 will be described in detail with reference to FIG. 1, and problems caused by the application of the configuration will be summarized. FIG. 1 is an explanatory view illustrating an example of the configuration of an OFDM-using visible ray communication system LS1.
- [34] As shown in FIG. 1, a visible ray communication system LS1 includes a transmission apparatus 10, and a reception apparatus 30. The transmission apparatus 10 has an S/P converter 12, a modulator 14, an IFFT unit, a driver circuit 22, and a light emitting device 24. Herein, the IFFT unit includes a multiplier 16 and an adder 20. The reception apparatus 30 has a light receiving device 32, an FFT unit, a demodulator 38, and a P/S converter 40. Herein, the FFT unit includes a multiplier 34, and an integrating circuit 36. The FFT is an abbreviation of Fast Fourier Transform, and the IFFT is an abbreviation of Inverse FFT.
- [35] Transmission data d is serial-to-parallel converted by the S/P converter 12. Then, from the S/P converter 12, data streams are output equal to the number of carriers. Meanwhile, in the following description, the number of carriers is n . The data stream corresponding to each carrier, output from the S/P converter 12, is modulated with a pre-determined number of dimensions (for example, 2) by the modulator 14. Then, from the modulator 14, a modulated signal is output. The modulated signal of each carrier, output from the modulator 14, is input to the IFFT unit. Thus, to the IFFT, modulated signals are input equal to the number of the carriers. The IFFT unit is a means for performing IFFT on the input modulated signals equal to the number of carriers. First, the modulated signals input to the IFFT unit are multiplied by carrier sinusoidal (sine wave) signals in the multiplier 16. Herein, n carrier sinusoidal signals $\cos(2\pi f_1 t) \sim \cos(2\pi f_n t)$ corresponding to carrier frequencies $f_1 \sim f_n$ are orthogonal to each other. Each modulated signal (hereinafter, a carrier signal), which has been multiplied by the carrier sinusoidal signal, is input to the adder 20. In the adder 20, respective carrier signals are added to each other to generate OFDM signals.
- [36] An OFDM signal generated by the adder 20 is input to the driver circuit 22. The driver circuit 22 is a drive circuit for driving the light emitting device 24 (LED(W)). When the OFDM signal is input, the driver circuit 22 controls the current quantity supplied to the light emitting device 24 based on the input OFDM signal, and emits the light of the light emitting device 24 with the emission intensity according to the signal amplitude of the OFDM signal. The light generated from the light emitting device 24 is

received by the light receiving device 32 of the reception apparatus 30. The light receiving device 32 is a photoelectric converting element. For this reason, when the light is received by the light receiving device 32, an electrical signal (hereinafter, referred to as a reception signal) according to the intensity of the received light is output. The reception signal output from the light receiving device 32 is input to the FFT unit. The FFT unit is a means for performing FFT on the reception signal to extract each carrier frequency component.

[37] The reception signal output from the light receiving device 32 is input to the multiplier 34, and is multiplied by a carrier sinusoidal signal corresponding to each of carrier frequencies $f_1 \sim f_n$. The reception signal, which has been multiplied by each carrier sinusoidal signal in the multiplier 34, is input to the integrating circuit 36. In the integrating circuit 36, the signal output from the multiplier 34 is subjected to an integrating operation in an integration interval up to an OFDM symbol length (T) on a time axis, and a signal component corresponding to each of carrier frequencies $f_1 \sim f_n$ is extracted. Each carrier frequency component extracted from the integrating circuit 36 is input to the demodulator 38. Each carrier frequency component corresponds to each carrier signal. For this reason, when each carrier frequency component is demodulated by the demodulator 38, a data stream corresponding to each carrier signal is restored. Each data stream restored in the demodulator 38 is input to the P/S converter 40 to restore the transmission data d.

[38] Through such a configuration, it is possible to improve the frequency use efficiency and the endurance against multi-path, and to significantly improve the communication quality. However, an increase in PAPR, peculiar to OFDM, is caused because respective carrier frequency components are added to each other in the front end of the driver circuit 22 of the transmission apparatus, and the light emitting device 24 is driven based on the OFDM signals obtained through the addition. Accordingly, the performance requirement for a high dynamic range is imposed on the driver circuit 22, and the light emitting device 24. For this reason, it is very difficult, in reality, to use the OFDM visible ray communication in a general illuminating device. Also, a driver circuit 22 or a light emitting device 24 which can satisfy such performance requirements is expensive. This relates to an increase in the manufacturing cost of a transmitter. As described above, the difficulty in the use of a conventional infrastructure increases the installation cost. In the embodiments which will be described later, the configurations of transmitters made in consideration of these problems will be proposed. The transmitters can remove the influence of a high PAPR caused by OFDM and reduce the performance requirement for the dynamic range of the driver circuit 22 and the light emitting device 24.

[39] <Embodiment>

- [40] Hereinafter, one embodiment of the present invention will be described. In the present embodiment, IFFT is not performed at a transmission-side, and for each carrier, a light emitting device is directly driven. This is for reducing the performance requirements imposed on a driver circuit and a light emitting device.
- [41] [Configuration of a visible ray communication system LS2]
- [42] First, the configuration of a visible ray communication system LS2 related to the present embodiment will be described with reference to FIG. 2. FIG. 2 is an explanatory view illustrating an example of the configuration of a visible ray communication system LS2 according to the present embodiment.
- [43] As shown in FIG. 2, the visible ray communication system LS2 includes a transmission apparatus 100, and a reception apparatus 200. The transmission apparatus 100 has an S/P converter 102, a modulator 104, a multiplier 106, a driver circuit 110, and a light emitting device 112. Meanwhile, the reception apparatus 200 has a light receiving device 202, an FFT unit, a demodulator 208, and a P/S converter 210. Herein, the FFT unit includes a multiplier 204, and an integrating circuit 206.
- [44] Transmission data d is serial-to-parallel converted by the S/P converter 102. Then, from the S/P converter 102, data streams are output equal to the number of carriers. Meanwhile, in the following description, the number of carriers is n . The data stream corresponding to each carrier, output from the S/P converter 102, is modulated with a pre-determined number of dimensions (for example, 2) by the modulator 104. Then, from the modulator 104, a modulated signal is output. The modulated signal of each carrier, output from the modulator 104, is input to the multiplier 106. In the multiplier 106, the modulated signal is multiplied by a carrier sinusoidal signal $\cos(2\pi f_1 t) \sim \cos(2\pi f_n t)$ corresponding to each of carrier frequencies $f_1 \sim f_n$. Herein, n carrier sinusoidal signals corresponding to carrier frequencies $f_1 \sim f_n$ are orthogonal to each other.
- [45] Each modulated signal (hereinafter, a carrier signal), which has been multiplied by the carrier sinusoidal signal in the multiplier 106, is input to the driver circuit 110. The driver circuit 110 is provided in each light emitting device 112 (LED(W1)~LED(Wn)), and is used to drive each light emitting device 112 (LED(W1)~LED(Wn)). When the carrier signal is input, the driver circuit 110 controls the current quantity supplied to the light emitting device 112 based on the input carrier signal, and emits the light of each light emitting device 112 with the emission intensity according to the signal amplitude of the carrier signal. The light generated from each light emitting device 112 is spatially multiplexed in a transmission line, and is received by the light receiving device 202 of the reception apparatus 200. The light receiving device 202, for example, includes one PD (Photo Diode). When the light is received, an electrical signal (hereinafter, referred to as a reception signal) according to the intensity of the received

light is output from the light receiving device 202. The reception signal output from the light receiving device 202 is input to the FFT unit. The FFT unit is a means for performing FFT on the reception signal to extract each carrier frequency component.

[46] The reception signal output from the light receiving device 202 is input to the multiplier 204, and is multiplied by a carrier sinusoidal signal $\cos(2\pi f_1 t) \sim \cos(2\pi f_n t)$ corresponding to each of carrier frequencies $f_1 \sim f_n$. The reception signal, which has been multiplied by each carrier sinusoidal signal in the multiplier 204, is input to the integrating circuit 206. In the integrating circuit 206, the signal output from the multiplier 204 is subjected to an integrating operation in an integration interval up to an OFDM symbol length (T) on a time axis, and a signal component corresponding to each of carrier frequencies $f_1 \sim f_n$ is extracted. Each carrier frequency component extracted from the integrating circuit 206 is input to the demodulator 208. Each carrier frequency component corresponds to each carrier signal. For this reason, when each carrier frequency component is demodulated by the demodulator 208, a data stream corresponding to each carrier signal is restored. Each data stream restored in the demodulator 208 is input to the P/S converter 210 to restore the transmission data d.

[47] In the above described configuration of the visible ray communication system LS2 according to the present embodiment, respective carrier signals corresponding to respective carrier frequencies are not added to each other in the front end of the driver circuit 110, and the light of each light emitting device 112 is emitted with the emission intensity according to the signal amplitude of each carrier signal. As described above, since respective carrier signals are not added to each other in the front end of the driver circuit 110, a high PAPR (a problem in OFDM) is not caused, and a dynamic range required for the driver circuit 110 and the light emitting device 112, corresponding to each carrier frequency, can be controlled to be low. As a result, by using a miniaturized and inexpensive LED driving circuit (or LED), the improvement of communication performance, similar to that achieved by OFDM, can be achieved. For example, a visible ray communication system capable of improving the frequency use efficiency and the endurance against multi-path by effectively utilizing a conventional infrastructure can be achieved.

[48] [Configuration of a visible ray communication system LS3]

[49] Hereinafter, the configuration of a visible ray communication system LS3, that is, one modified embodiment of the visible ray communication system LS2 according to the present embodiment, will be described with reference to FIG. 3. FIG. 3 is a view illustrating an example of the configuration of a visible ray communication system LS3 according to one modified embodiment of the present embodiment.

[50] As shown in FIG. 3, the visible ray communication system LS3 includes a transmission apparatus 100, and a reception apparatus 200. The transmission apparatus

100 has an S/P converter 102, a modulator 104, a multiplier 106, a driver circuit 110, and a light emitting device 112. In other words, the configuration of the transmission apparatus 100 is the same as that of the visible ray communication system LS2.

Meanwhile, the reception apparatus 200 has an image sensor 232, a DFT unit, a demodulator 208, and a P/S converter 210. Herein, the DFT unit includes a multiplier 204, and an integrating circuit 206. The DFT is an abbreviation of Discrete Fourier Transform. As described above, the visible ray communication system LS3 is mainly different from the visible ray communication system LS2 in the light receiving means of the reception apparatus 200. Therefore, the following description is on the difference in the light receiving means.

- [51] The image sensor 232 is a means for converting lights generated from a plurality of light emitting devices 112 of the transmission apparatus 100 into reception signals. Herein, the image sensor 232 can specify each light emitting device 112 according to the light receiving position. For example, the image sensor 232 can specify the light received in the pixel of a position (X1,Y1) as the light emitted from the light emitting device 112 (LED(W1)) of the transmission apparatus 100. In this manner, the light input to each pixel of the image sensor 232 is determined as the light emitted from each light emitting device 112. For this reason, the image sensor 232 inputs the reception signal according to the reception intensity of the light emitted from each light emitting device 112, to the DFT unit. Herein, the reason why DFT, instead of FFT, is used for extracting a modulated signal of each carrier frequency is that in the output of the image sensor 232, signals has already been separated according to carrier frequencies. In the output of the image sensor 232, the DFT is performed, and according to the result, demodulation is performed in the demodulator 208. Also, serial-to-parallel conversion is performed in the P/S converter 210 to restore the transmission data d.

- [52] In the above described configuration of the visible ray communication system LS3 according to one modified embodiment of the present embodiment, it is possible to control the dynamic range of the light receiving means of the reception apparatus 200 to be low.

- [53] [Configuration of a visible ray communication system LS4]

- [54] Hereinafter, the configuration of a visible ray communication system LS4, that is, one modified embodiment of the visible ray communication system LS2 according to the present embodiment, will be described with reference to FIG. 4. FIG. 4 is an explanatory view illustrating an example of the configuration of a visible ray communication system LS4 according to one modified embodiment of the present embodiment.

- [55] As shown in FIG. 4, the visible ray communication system LS4 includes a

transmission apparatus 100, and a reception apparatus 200. The transmission apparatus 100 has an S/P converter 102, a modulator 104, a multiplier 106, a driver circuit 110, and a light emitting device 152. Herein, a plurality of light emitting devices 152 provided in the transmission apparatus 100 of the present modified embodiment radiates with different colors (optical frequency of $C_1 \sim C_n$). Meanwhile, the reception apparatus 200 has a light receiving device 252, a DFT unit, a demodulator 208, and a P/S converter 210. Herein, the DFT unit includes a multiplier 204, and an integrating circuit 206. As described above, the visible ray communication system LS4 is mainly different from the visible ray communication system LS2 in the light emitting means of the transmission apparatus 100, and the light receiving means of the reception apparatus 200. Therefore, the following description is on the difference in the means.

[56] Like the visible ray communication system LS2, each light emitting device 152 (LED(C_1)~LED(C_n)) radiates with the emission intensity according to the signal amplitude of the carrier signal corresponding to each of carrier frequencies $f_1 \sim f_n$. Herein, each light emitting device 152 radiates lights with different colors ($C_1 \sim C_n$). It can be said that the present modified embodiment was made by combining the visible ray communication system LS2 of the present embodiment with a so-called WDM (Wave Length Division Multiplexing) technology, in that signals are allocated to respective colors $C_1 \sim C_n$ to multiplex the transmission line. The light generated from each light emitting device 152 with a color of $C_1 \sim C_n$ is received by each light receiving device 252 with a color of $C_1 \sim C_n$ in the reception apparatus 200. In the light receiving device 252, a PD (a so-called color sensor) having a filter of a corresponding color may be used. For the signal output from the light receiving device 252 of each color, DFT is performed in the DFT unit, demodulation is performed in the demodulator 208, and serial-to-parallel conversion is performed in the P/S converter 210 to restore the transmission data d.

[57] In the above described configuration of the visible ray communication system LS4 according to one modified embodiment of the present embodiment, it is possible to control the dynamic range of the light receiving means of the reception apparatus 200 to be low. Meanwhile, in the case of WDM, color interference caused by the optical frequency property of the light emitting device 152, and the light receiving device 252 is problematic. On the other hand, in the present modified embodiment, such color interference is improved because signals of respective colors can be separated from each other due to the orthogonality of an OFDM carrier. Accordingly, according to the present modified embodiment, it is possible to control the dynamic range required for the light emitting means and the light receiving means to be low while taking on the excellent communication property of OFDM, without consideration of the influence of color interference. As a result, it is possible to build a miniaturized and inexpensive

visible ray communication system with a high communication performance by using effectively using a conventional infrastructure.

[58] [Configuration of a visible ray communication system LS5]

[59] Hereinafter, the configuration of a visible ray communication system LS5, that is, one modified embodiment of the visible ray communication system LS2 according to the present embodiment, will be described with reference to FIG. 5. FIG. 5 is an explanatory view illustrating an example of the configuration of a visible ray communication system LS5 according to one modified embodiment of the present embodiment.

[60] As shown in FIG. 5, the visible ray communication system LS5 includes a transmission apparatus 100, and a reception apparatus 200. The transmission apparatus 100 has an S/P converter 102, a modulator 104, a multiplier 106, a driver circuit 110, and a light emitting device 112. The visible ray communication system LS5 is different from the visible ray communication system LS2 in the number of the driver circuits 110 and the light emitting devices 112. Especially, in the configuration in the present modified embodiment, the number N of the driver circuits 110 and the light emitting devices 112 is higher than the number n of carrier signals ($n < N$). Meanwhile, the configuration of the reception apparatus 200 is, in actuality, the same as that of the visible ray communication system LS2. As described above, the visible ray communication system LS5 is mainly different from the visible ray communication system LS2 in the light emitting means of the transmission apparatus 100.

[61] Transmission data d is serial-to-parallel converted by the S/P converter 102. Then, from the S/P converter 102, data streams are output equal to the number of carriers. Herein, the number of carriers is n . The data streams corresponding to each carrier, output from the S/P converter 102, are modulated with a pre-determined number of dimensions (for example, 2) by the modulator 104. Then, from the modulator 104, a modulated signal is output. The modulated signal of each carrier, output from the modulator 104, is input to the multiplier 106. In the multiplier 106, the modulated signal is multiplied by a carrier sinusoidal signal $\cos(2\pi f_1 t) \sim \cos(2\pi f_n t)$ corresponding to each of carrier frequencies $f_1 \sim f_n$. Herein, n carrier sinusoidal signals corresponding to carrier frequencies $f_1 \sim f_n$ are orthogonal to each other.

[62] The steps described so far are the same in those of the visible ray communication system LS2. However, the carrier signals output from the multiplier 106 are input to a plurality of driver circuits 110. For example, the carrier signal, which has been multiplied by the carrier sinusoidal signal $\cos(2\pi f_1 t)$ in the multiplier 106, is branched and input to two driver circuits 110 (D1, D2). The driver circuit 110 is provided in each light emitting device 112 (LED(W1)~LED(WN)), and is used to drive each light emitting device 112 (LED(W1)~LED(WN)). When the carrier signal is input, the

driver circuit 110 controls the current quantity supplied to the light emitting device 112 based on the input carrier signal, and emits the light of each light emitting device 112 with the emission intensity according to the signal amplitude of the carrier signal. This characteristic is the same with the visible ray communication system LS2. However, the visible ray communication system LS5 is different from the visible ray communication system LS2 in that the radiation of a plurality of light emitting devices 112 is controlled based on the same carrier signal. Through this configuration, the technology according to this embodiment can be preferably applied the case where the number N of the light emitting devices 112 is higher than the number n of carrier signals ($n < N$).

[63] In the above described configuration of the visible ray communication system LS5 according to one modified embodiment of the present embodiment, respective carrier signals corresponding to respective carrier frequencies are not added to each other in the front end of the driver circuit 110, and the light of each light emitting device 112 is emitted with the emission intensity according to the signal amplitude of each carrier signal. This property is the same with the case where the number N of the light emitting devices 112 is higher than the number n of carrier signals ($n < N$). Accordingly, since respective carrier signals are not added to each other in the front end of the driver circuit 110, a high PAPR (a problem in OFDM) is not caused, and a dynamic range required for the driver circuit 110 and the light emitting device 112, corresponding to each carrier frequency, can be controlled to be low. As a result, by using a miniaturized and inexpensive LED driving circuit (or LED), the improvement of communication performance, similar to that achieved by OFDM, can be achieved.

[64] [Configuration of a visible ray communication system LS6]

[65] Hereinafter, the configuration of a visible ray communication system LS6, that is, one modified embodiment of the visible ray communication system LS2 according to the present embodiment, will be described with reference to FIG. 6. FIG. 6 is an explanatory view illustrating an example of the configuration of a visible ray communication system LS6 according to one modified embodiment of the present embodiment.

[66] As shown in FIG. 6, the visible ray communication system LS6 includes a transmission apparatus 100, and a reception apparatus 200. The transmission apparatus 100 has an S/P converter 102, a modulator 104, a multiplier 106, a driver circuit 110, and a light emitting device 112. The visible ray communication system LS6 is different from the visible ray communication system LS2 in the number of the driver circuits 110 and the light emitting devices 112. Especially, in the configuration in the present modified embodiment, the number N of the driver circuits 110 and the light emitting devices 112 is lower than the number n of carrier signals ($n > N$). Also, unlike the visible ray communication system LS2, the visible ray communication system LS6

includes an adder provided at the rear end of the multiplier 106. Meanwhile, the visible ray communication system LS6 has, in actuality, the same configuration of the reception apparatus 200 as that of the visible ray communication system LS2. As described above, the visible ray communication system LS6 is mainly different from the visible ray communication system LS2 in the light emitting means of the transmission apparatus 100.

[67] Transmission data d is serial-to-parallel converted by the S/P converter 102. Then, from the S/P converter 102, data streams are output equal to the number of carriers. Herein, the number of carriers is n . The data stream corresponding to each carrier, output from the S/P converter 102, is modulated with a pre-determined number of dimensions (for example, 2) by the modulator 104. Then, from the modulator 104, a modulated signal is output. The modulated signal of each carrier, output from the modulator 104, is input to the multiplier 106. In the multiplier 106, the modulated signal is multiplied by a carrier sinusoidal signal $\cos(2\pi f_1 t) \sim \cos(2\pi f_n t)$ corresponding to each of carrier frequencies $f_1 \sim f_n$. Herein, n carrier sinusoidal signals corresponding to carrier frequencies $f_1 \sim f_n$ are orthogonal to each other.

[68] The steps described so far are the same in those of the visible ray communication system LS2. However, the carrier signals output from a plurality of multipliers 106 are added to each other by being input to the adder, and then input to the driver circuit 110. For example, the carrier signal, which has been multiplied by the carrier sinusoidal signal $\cos(2\pi f_1 t)$ in the multiplier 106, and the carrier signal, which has been multiplied by the carrier sinusoidal signal $\cos(2\pi f_2 t)$ in the multiplier 106, are added to each other by being input to the adder, and input to the driver circuit 110 (D1). The driver circuit 110 is provided in each light emitting device 112 (LED(W1)~LED(WN)), and is used to drive each light emitting device 112 (LED(W1)~LED(WN)). When the carrier signal is input, the driver circuit 110 controls the current quantity supplied to the light emitting device 112 based on the input carrier signal, and emits the light of each light emitting device 112 with the emission intensity according to the signal amplitude of the carrier signal. This characteristic is the same with the visible ray communication system LS2. However, unlike the visible ray communication system LS2, in the visible ray communication system LS6, the radiation of each light emitting device 112 is controlled based on the added carrier signals 112. Through this configuration, the technology according to this embodiment can be preferably applied the case where the number N of the light emitting devices 112 is lower than the number n of carrier signals ($n > N$).

[69] In the above described configuration of the visible ray communication system LS6 according to one modified embodiment of the present embodiment, respective carrier signals corresponding to respective carrier frequencies are not added to each other in

the front end of the driver circuit 110, and also, after the addition of some carrier signals, the light of each light emitting device 112 is emitted with the emission intensity according to the signal amplitude of each carrier signal. Accordingly, since respective carrier signals are not added to each other in the front end of the driver circuit 110, a high PAPR (a problem in OFDM) is not caused, and a dynamic range required for each driver circuit 110 and each light emitting device 112 can be controlled to be low. As a result, by using a miniaturized and inexpensive LED driving circuit (or LED), the improvement of communication performance, similar to that achieved by OFDM, can be achieved.

[70] Although preferred embodiments of the present invention have been illustrated with reference to the accompanying drawings, it will be understood that the present invention is not limited to the embodiments disclosed. Accordingly, it will be appreciated by those skilled in the art that various changes and modifications may be made within the scope of the appended claims. Such changes and modifications will be apparent to those skilled in the art without departing from the spirit and scope of the present invention.

Industrial Applicability

[71] While the invention has been shown and described with reference to certain exemplary embodiments thereof, it will be understood by those skilled in the art that various changes in form and details may be made therein without departing from the spirit and scope of the invention as defined by the appended claims.

Claims

- [Claim 1] A visible ray communication system comprising a transmission apparatus and a reception apparatus, wherein the transmission apparatus comprises:
a plurality of light emitting devices;
a serial-to-parallel (S/P) converter for serial-to-parallel converting transmission data, thereby generating N data streams;
a modulator for modulating the N data streams generated by the S/P converter for respective carriers with a predetermined number of dimensions, thereby generating N modulated signals;
a carrier signal multiplier for multiplying the N modulated signals generated by the modulator by N carrier signals orthogonal to the N modulated signals, respectively, thereby generating N transmission signals; and
a light emitting control unit for illuminating the plurality of light emitting devices according to the N transmission signals generated by the carrier signal multiplier, and
the reception apparatus comprises:
a light receiving device for receiving lights, the lights being emitted from the plurality of light emitting devices of the transmission apparatus and spatially multiplexed in a transmission line, thereby outputting reception signals according to corresponding reception intensities;
an FFT unit for performing FFT on the reception signals output from the light receiving device by using the N carrier signals, thereby extracting the N modulated signals of the respective carriers; and
a demodulator for demodulating each of the modulated signals extracted from the FFT unit.
- [Claim 2] The visible ray communication system as claimed in claim 1, wherein when a number N of the light emitting devices is greater than a number n of the carrier signals ($N > n$), the light emitting control unit illuminates multiple devices of the light emitting devices at once based on one of the transmission signals.
- [Claim 3] The visible ray communication system as claimed in claim 1, wherein when a number N of the light emitting devices is less than a number n of the carrier signals ($N < n$), the light emitting control unit adds M ($2 \leq M < n$) signals of the transmission signals, and illuminates the light

emitting devices based on the transmission signals obtained through the addition.

[Claim 4] The visible ray communication system as claimed in any one of claims 1 to 3, wherein the reception apparatus comprises, as the light receiving device, an image sensor for detecting intensity of each of the lights emitted from the plurality of light emitting devices, and outputting a reception signal corresponding to each of the light emitting devices.

[Claim 5] The visible ray communication system as claimed in any one of claims 1 to 3, wherein the transmission apparatus comprises the plurality of light emitting devices radiating differently colored lights, and the reception apparatus comprises a plurality of light receiving devices for receiving the differently colored lights, and outputting reception signals based on corresponding reception intensities.

[Claim 6] A transmission apparatus comprising:
a plurality of light emitting devices;
an S/P converter for serial-to-parallel converting transmission data, thereby generating N data streams;
a modulator for modulating the N data streams generated by the S/P converter for respective carriers with a predetermined number of dimensions, thereby generating N modulated signals;
a carrier signal multiplier for multiplying the N modulated signals generated by the modulator by N carrier signals orthogonal to the N modulated signals, respectively, thereby generating N transmission signals; and
a light emitting control unit for illuminating the plurality of light emitting devices according to the N transmission signals generated by the carrier signal multiplier.

[Claim 7] A signal transmission method comprising the steps of:
serial-to-parallel converting transmission data by a transmission apparatus comprising a plurality of light emitting devices, thereby generating N data streams;
modulating the generated N data streams for respective carriers with a predetermined number of dimensions, by the transmission apparatus, thereby generating N modulated signals;
multiplying the generated N modulated signals by N carrier signals orthogonal to the N modulated signals, respectively, by the transmission apparatus, thereby generating N transmission signals;
illuminating the plurality of light emitting devices according to the

generated N transmission signals by the transmission apparatus;
performing, by a reception apparatus comprising a light receiving device for receiving lights emitted from the plurality of light emitting devices of the transmission apparatus and outputting reception signals according to corresponding reception intensities, the lights being spatially multiplexed in a transmission line, FFT on the reception signals output from the light receiving device by using the N carrier signals, thereby extracting the N modulated signals of the respective carriers; and

demodulating each of the extracted modulated signals, by the reception apparatus.

[Claim 8]

A signal transmission method by a transmission apparatus comprising a plurality of light emitting devices, the signal transmission method comprising the steps of:

serial-to-parallel converting transmission data, thereby generating N data streams;

modulating the generated N data streams for respective carriers with a predetermined number of dimensions, thereby generating N modulated signals;

multiplying the generated N modulated signals by N carrier signals orthogonal to the N modulated signals, respectively, thereby generating N transmission signals; and

illuminating the plurality of light emitting devices according to the generated N transmission signals.

[Fig. 1]

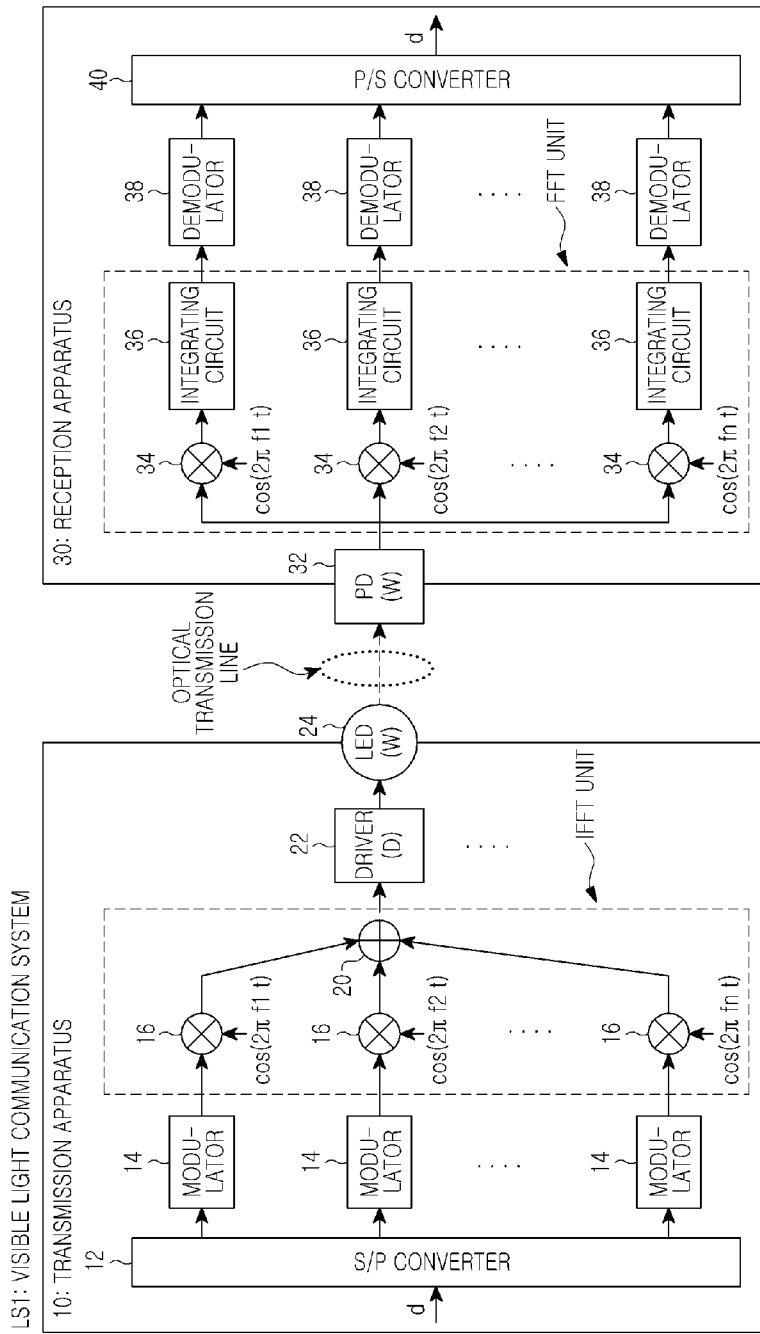

[Fig. 2]

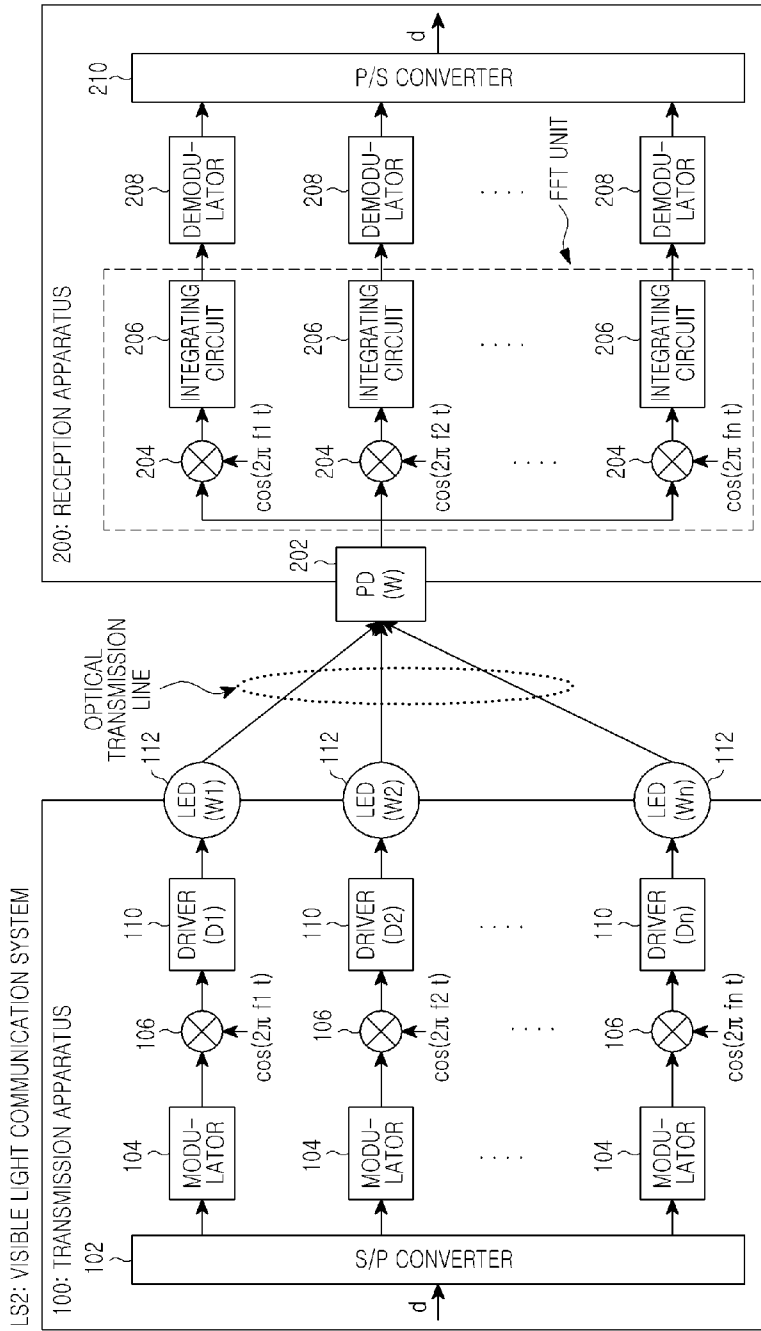

[Fig. 3]

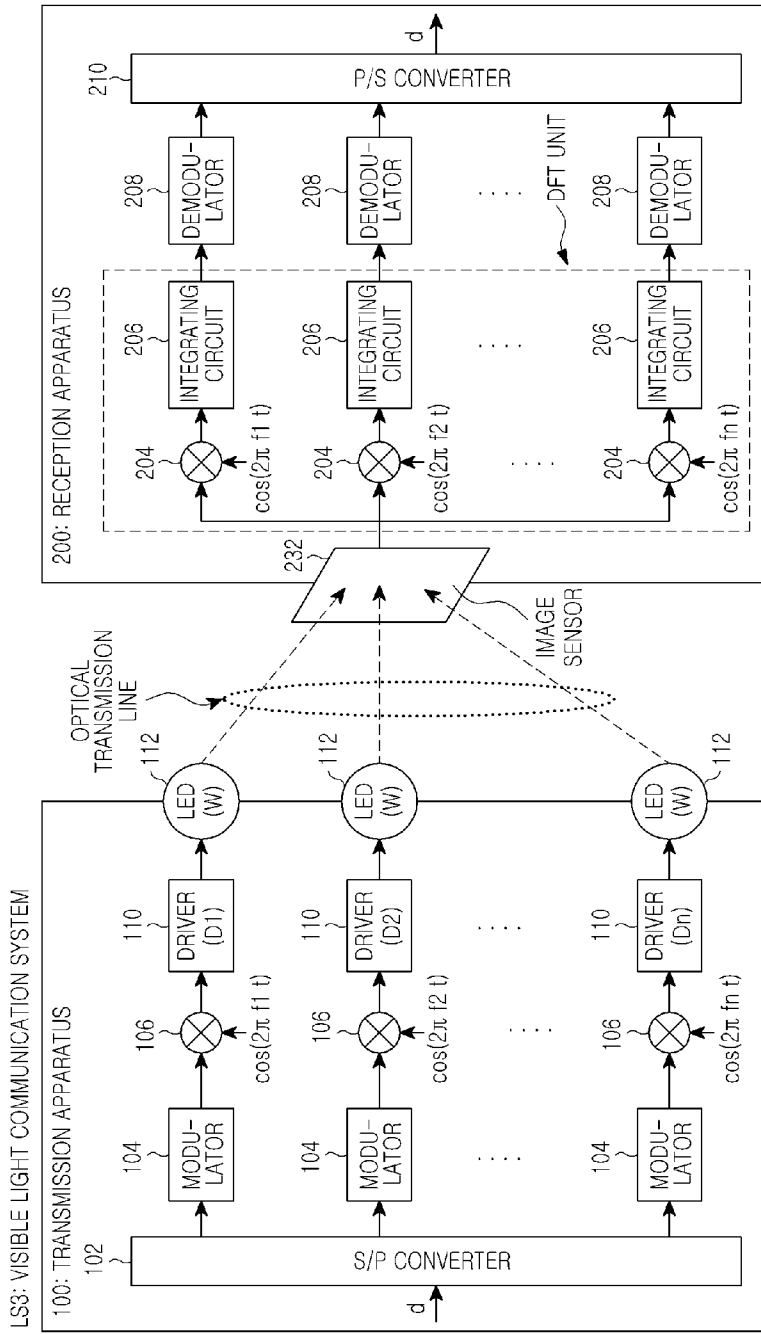

[Fig. 4]

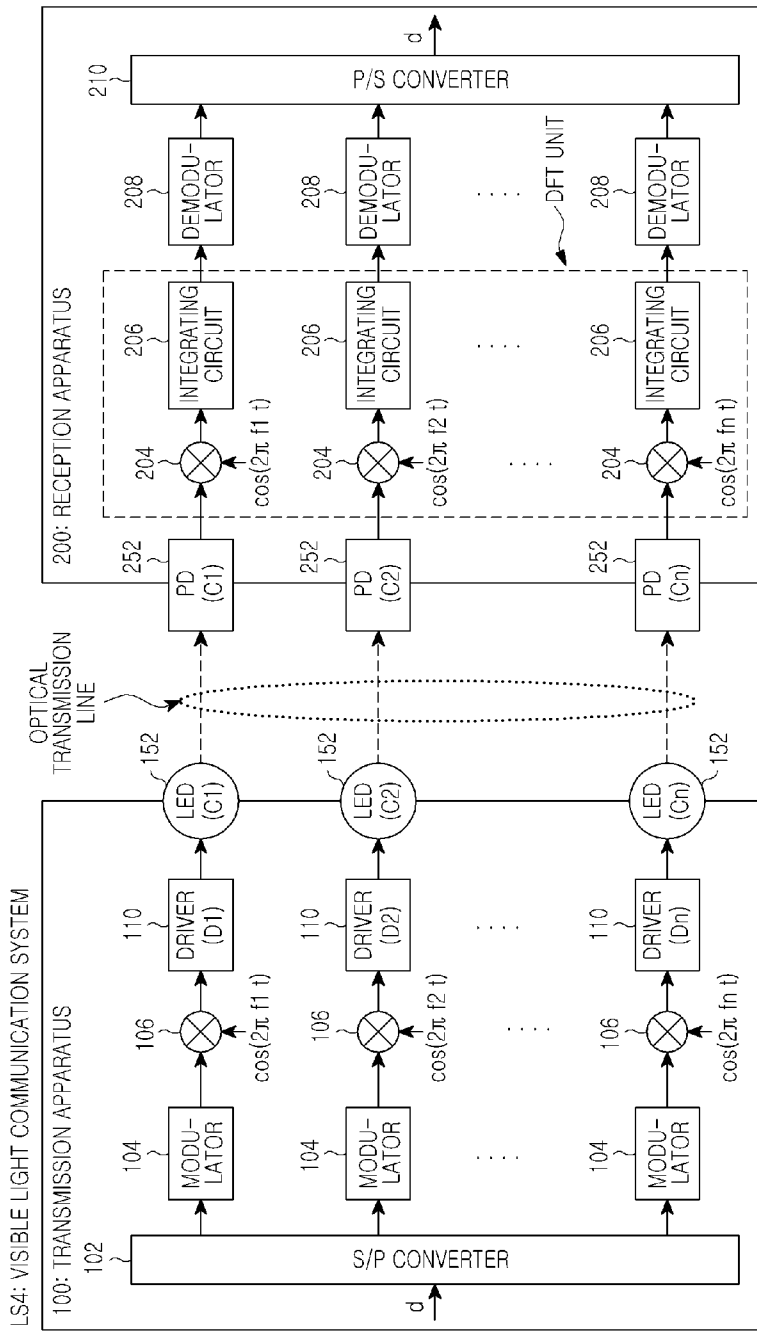

[Fig. 5]

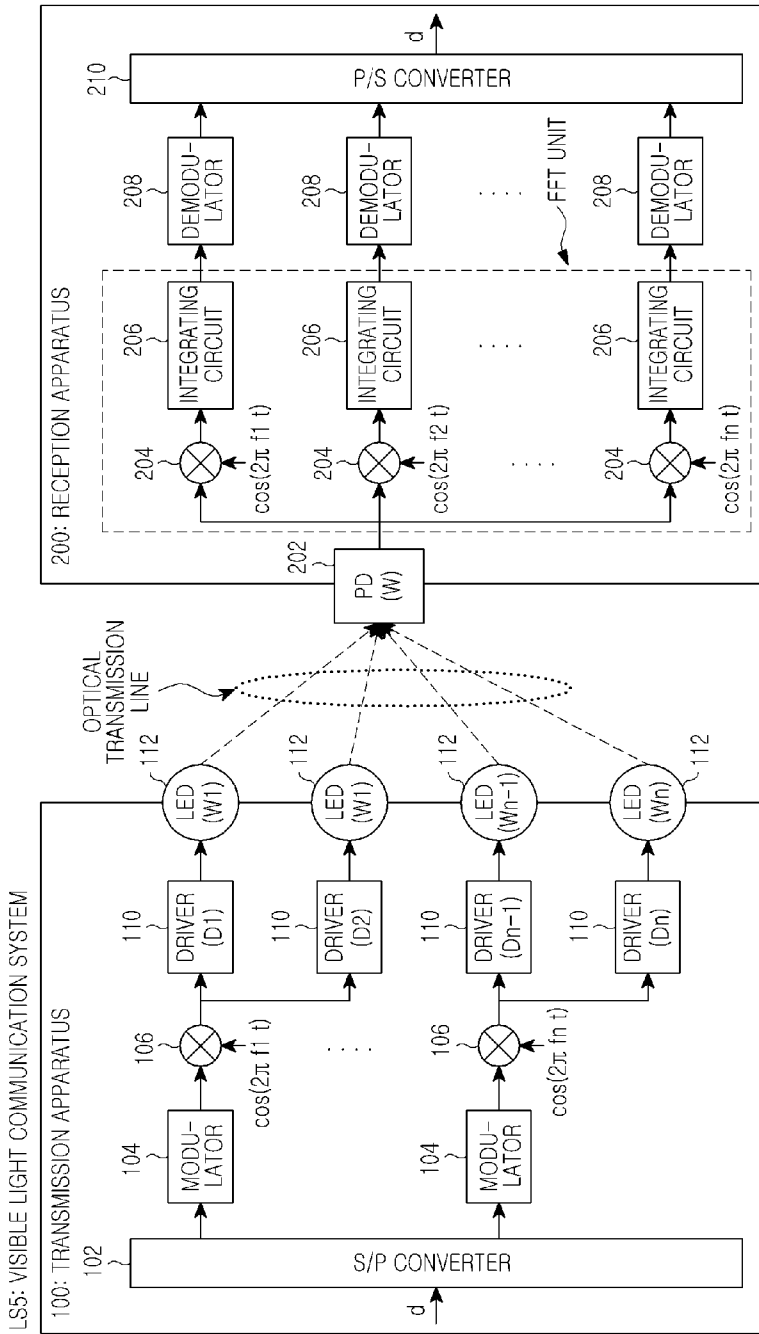

[Fig. 6]

