



(43) International Publication Date
19 January 2023 (19.01.2023)

(51) International Patent Classification:

A01K 61/60 (2017.01) *F16G 11/04* (2006.01)
A01K 75/00 (2006.01) *F16G 11/10* (2006.01)
B63H 8/18 (2020.01)

(21) International Application Number:

PCT/NO2022/050175

(22) International Filing Date:

12 July 2022 (12.07.2022)

(25) Filing Language:

English

(26) Publication Language:

English

(30) Priority Data:

20210906 14 July 2021 (14.07.2021) NO

(71) Applicant: SCALE AQUACULTURE AS [NO/NO];
Postboks 2200, 7412 Trondheim (NO).

(72) Inventor: FURBERG, Geir; Hestøyveien 12, 7270 Dyrvik
(NO).

(74) Agent: ACAPO AS; P.O Box 1880 Nordnes, 5817 Bergen
(NO).

(81) Designated States (unless otherwise indicated, for every

kind of national protection available): AE, AG, AL, AM, AO, AT, AU, AZ, BA, BB, BG, BH, BN, BR, BW, BY, BZ, CA, CH, CL, CN, CO, CR, CU, CV, CZ, DE, DJ, DK, DM, DO, DZ, EC, EE, EG, ES, FI, GB, GD, GE, GH, GM, GT, HN, HR, HU, ID, IL, IN, IQ, IR, IS, IT, JM, JO, JP, KE, KG, KH, KN, KP, KR, KW, KZ, LA, LC, LK, LR, LS, LU, LY, MA, MD, ME, MG, MK, MN, MW, MX, MY, MZ, NA, NG, NI, NO, NZ, OM, PA, PE, PG, PH, PL, PT, QA, RO, RS, RU, RW, SA, SC, SD, SE, SG, SK, SL, ST, SV, SY, TH, TJ, TM, TN, TR, TT, TZ, UA, UG, US, UZ, VC, VN, WS, ZA, ZM, ZW.

(84) Designated States (unless otherwise indicated, for every

kind of regional protection available): ARIPO (BW, GH, GM, KE, LR, LS, MW, MZ, NA, RW, SD, SL, ST, SZ, TZ, UG, ZM, ZW), Eurasian (AM, AZ, BY, KG, KZ, RU, TJ, TM), European (AL, AT, BE, BG, CH, CY, CZ, DE, DK, EE, ES, FI, FR, GB, GR, HR, HU, IE, IS, IT, LT, LU, LV, MC, MK, MT, NL, NO, PL, PT, RO, RS, SE, SI, SK, SM, TR), OAPI (BF, BJ, CF, CG, CI, CM, GA, GN, GQ, GW, KM, ML, MR, NE, SN, TD, TG).

(54) Title: BAG FOR A FISH CAGE

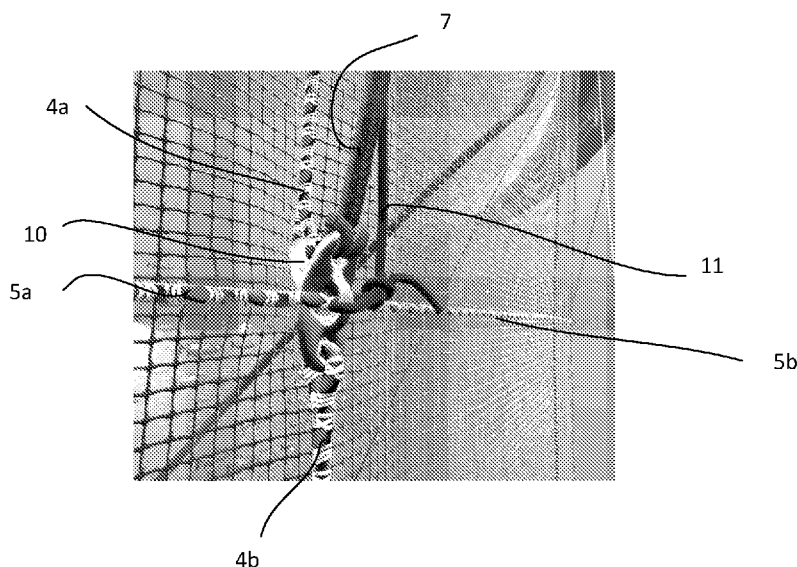

Fig. 3

(57) Abstract: Bag (3) for a fish cage, having a number of lines (4, 5) running along the length and the circumference of the bag, the lines are connected to the bag. At least one of the lines (4) running along the length, and at least one of the lines (5) running along the circumference of the bag, each comprise several parts (4a, 4b, 5a, 5b) being connected to each other at cross points (8) by a separate connection device (10), to create continuous lines around the circumference of the bag, and continuous lines along the whole length of the bag.



Published:

- *with international search report (Art. 21(3))*
- *before the expiration of the time limit for amending the claims and to be republished in the event of receipt of amendments (Rule 48.2(h))*

Bag for a fish cage

This invention relates to a new type of bag for a fish cage, a fish cage having such a bag and a connection device to be used in a bag, according to the preamble of the independent patent claims.

Background

Aquaculture has changed considerably over the years, and is now a major industry. Most of the farmed animals are still farmed in traditional fish cages at the sea, even if aquaculture based on shore is growing. A traditional fish cage at sea comprises among others a floating collar at the surface of the sea, a bag fastened to the collar and surrounding all the farmed organisms, and weights to keep the bag dilated and in shape. The bag may be made of a material having meshes, such as a net, the weight will also contribute to stretching the bag in such a way that the meshes of the net is open.

The floating collar is traditionally round and may comprise two tubes and handrail in plastic, fastened to each other by steel or plastic brackets. The weight may be any suitable weight, such as a sinker tube which may be fastened to the bag in the transition between wall and bottom. The weights are arranged on the outside of the net cage.

The bag may traditionally comprise a net wall and net bottom, the bottom may be flat or shaped as a cone. The material of the bag may be reinforced with horizontal and vertical lines, where the horizontal lines are often referred to as waistlines. Vertical lines, often denoted lifting ropes, run along the wall of the bag from the upper edge, crossing the transition from bag wall to bag bottom, and is referred to as cross ropes when being a part of the bottom. The lines are fastened to the material of the bag.

The horizontal and vertical lines may transfer the weight of the bag and any equipment installed in it to the floating collar. A fish cage bag is large and heavy, and there is a risk that just the weight of the bag itself may create ruptures of the

material. By adding such lines the load carrying capacity of the bag increases, the number of lines, the type of line and the size of the lines must be calculated according to the intended use and localization of the fish cage, and is obvious to a skilled person. Further, the material of the bag may be elastic and the size of the bag
5 may thus be expanded as a result of forces acting on it. The horizontal and vertical lines are preferably less elastic, and thus they contribute to keeping the fish cage in its intended shape.

Each vertical line and each horizontal line is a continuous piece, and crosses each
10 other in cross points, preferably perpendicularly. In such cross points the horizontal line are attached to the vertical line either by knotting, splicing, sewing lacing or the similar. As the lines are attached to each other, any forces acting on the horizontal line will be transferred to the vertical line and vice versa, and thereby the total strength of the bag increases. However, when forces are acting on the bag, the lines
15 will move in different directions, and the connection between the lines will experience some tear and wear.

There is a general concern in aquaculture that fish escape from the plant, often due to holes in the the bag. The holes may arise due to equipment arranged in the fish
20 cage, wear and tear of the cage, defects or extreme weather. This is an environmental concern as farmed fish may get mixed with wild fish, but it is also an economical loss to the fish farming industry.

Many different types of fish cages are known, for instance from WO2014/189383 and
25 WO2010/087713. However, none of these fish cages solve the problems related to wear and tear of the net.

A main object of the present invention is thus to provide a fish cage whereby the risk of rupture or a hole in the bag is reduced. Another object of the present invention is
30 to provide a bag wherein only worn parts may be replaced. Yet another object is to provide an improved bag which may be used with existing equipment such as

floating collar and sinker tube. Finally it is an object to provide a fish cage and a bag being designed for all kinds of weather and ocean currents.

The invention

- 5 The objects are met by a fish cage, bag and connection device according to the characterizing part of the independent patent claims. Further advantageous features are stated in the independent claims.

The invention relates to a bag for a fish cage, having a number lines connected to the bag. The lines are running along the length and circumference of the bag, which will be vertically and horizontally once the fish cage is arranged in water, respectively. The lines crosses each other in cross points. At least one of the vertical lines running along the length of the bag comprises several parts being connected to each other by a connection device to create a continuous line along the whole length of the bag. Further, at least one of the horizontal lines comprises several parts being connected to each other by a connection device, to create a continuous line around the circumference of the bag. The parts of the at least one line running along the length of the bag are connected to the same connection device as the parts of the at least one line running along the circumference of the bag, the connection device is arranged at the cross points.

By arranging the lines in this way, they will not touch each other, and any wear between the lines will be avoided. Still, as they are connected to the same device, any forces acting on one line will be transferred to the other lines, and thus the strength of the bag is not reduced.

By "bag" it is in this patent application mainly meant the bag holding the fish inside the fish cage, but it may also be used as an external bag to the keep predators out of the fish cage. The bag is preferably made with walls and bottom, and is shaped as a circular cylinder with conical bottom. The bag may also have walls inclining towards each other without a defined bottom. When installed in a fish cage, the upper part of the bag is fastened to the floating collar, while the lower part, preferably lower part of

the wall or the transition between wall and bottom, is fastened to weights, such as a sinker tube. The bag is made of a material chosen according to criteria well known to a skilled person, and the intended use. The bag is preferably made of a material having meshes with a convenient mesh width, and may also be referred to as a net
5 cage.

By «line» it is in this patent application meant any convenient rope, strap or the similar.

10 By "several parts" it is in this patent application meant two or more parts, wherein each part is running from one connection device to the next. In addition the lines may comprise parts running from the connection device to the the floating collar, from the device to the weights, to the mooring or to the bottom. The number of parts will thus depend on the number of connection devices. Preferably, but not necessarily, a
15 connection device is arranged in each cross point, and then one horizontal line will comprise a number of parts being equal to the number of vertical lines. A horizontal line is preferably arranged at the top and bottom of the bag, and therefore one vertical line will comprise a number of parts being equal to the number of horizontal lines minus one. The arrangement and number of lines is obvious to a skilled person,
20 which also immediately will understand the number of parts necessary once the number of crossing points and connection devices are known.

As a line comprises several parts, in case any parts or lines are damaged or worn, only the affected part or parts need to be replaced, while the remaining parts and the
25 bag may be intact.

The connection device is designed to have room for at least four lines being attached to the device, without the lines being in contact with each other. A possible shape is shaped as a ring or square, where the lines are attached to the device opposite each
30 other.

- A preferred connection device has at least four separate attachment members, one for each line. Then, at the crossing point, an end of each line is attached to a separate member of the device. The attachment members are separate from each other, meaning that parts of the device will prevent a line attached to one member to come into contact with a line attached to another member. The attachment members are preferably arranged in pairs opposite each other. The attachment members are preferably, holes, slits, apertures, loops or the similar through the material of the connection device, whereby the lines may be treaded or guided through.
- 10 The attachment between the lines and the connection device, and the shape and design of the attachment member may vary according to the use and location of the connection device, and may even be adjusted as desired. For instance, when a line carrying much load, such as a vertical or horizontal line described above, should be attached to the connection device, the member must be shaped to withstand the
- 15 forces. When a line not carrying much load, or a line to be used only during installation should be attached to the connection device, the member may have a different shape and design. This will be obvious to a skilled person. The same regards the attachment to the member.
- 20 The parts of the horizontal line running along the circumference of the bag are preferably connected to the connection device at parts or members opposite to each other, and the parts of the vertical line are preferably attached to remaining opposite parts or members. By attaching the lines to the connection device in this way, the cross point will remain perpendicular and the lines will not be in direct contact with
- 25 each other. Any wear and tear between the lines is thus avoided.

The end of the line being attached to the connection means is preferably bent back to the line itself and fastened to the line in such a way that a loop is created on the end of the line. The fastening of the end of the line may be performed by sewing,

30 splicing, knotting or the similar. The fastening may further be secured by separate lines, for instance a lacing. In this way the lines will not be in contact with each other, and no tear and wear between the lines will occur. Forces will be transferred through

the connection device in a similar way as in prior art where the lines are attached to each other directly.

5 Depending on the construction of the fish cage and the bag, more lines may be attached to the connection device. The connection device may preferably comprise more connection members, and each line is connected to a separate member.

10 The device is made of a sufficiently strong and preferably non-elastic material, which tolerate the harsh environments of a fish cage at sea. A preferred material is metal such as steel.

The bag is preferably made of a mesh material, more preferred of a net as used in traditional fish cages.

15 The lines carry the weight of the bag and possible equipment, and are preferably made of fiber rope. The lines are preferably being sewn to the material of the bag, such as a net, but other methods such as tying or knotting to the net, to the line itself or to other lines, may also be used. The lower weights of the fish cage, possibly a sinker tube maintain stretch of the bag, and keeps the lower part of the bag dilated.

20 The vertical lines will be held straight by the weights, and since the vertical and horizontal lines are connected to each other at the cross points, the horizontal lines will be pulled outwards, and the fish cage will be held dilated over the whole depth of the bag, and during most conditions and sea currents. If the bag is made of net, the dilation will ensure good opening of the meshes in all parts of the net cage, which will

25 ensure good through-put of water, and thus sufficient supply of oxygen. By connecting the horizontal and vertical lines together in a connection device any tear between the lines will be reduced.

30 In another aspect, the invention relates to a fish cage comprising a bag as described above, having a number of lines running along the whole length and circumference of the bag. The bag and the lines are attached to a floating collar, floating at the surface of the sea once the fish cage is installed. When the lines are attached to the

floating collar, the weight of the bag with equipment and all forces acting on the bag, will be transferred to the floating collar through the lines. The forces acting on the bag, or the material of the bag, will thus be reduced, and the risk for rupture is reduced.

5

The fish cage may preferably comprise weights, such as bottom weights, sinker tube or the corresponding, to keep the bag dilated and in correct position. These weights may be attached to the lines, or by separate additional lines attached to the connection devices. In this way, the forces from the weights will also be transferred, through the connection device, to the vertical lines, and to the floating collar without adding any forces to the bag or the material of the bag.

10

The vertical lines may be attached to the net continuously, or they may be running partly without attachment to the net, such as from an upper connection device to the floating collar. Preferably the lines are attached to the floating collar in such a way that the upper part of the lines are forming an inclined angle towards the net cage. In this way the forces are better distributed in the floating collar, and a stretch in the upper part of the net cage is achieved, in such a way that it is kept dilated. This may also, or in addition, be achieved by separate, additional lines attached to an upper connection device, and running to the floating collar.

15

20

When additional lines for instance as described above, are attached to the connection device, the connection device preferably comprises more attachment members, and the additional lines are attached to the members. This will ensure a good transfer of forces, less forces on the bag and a minimum or no tear and wear between the lines and the bag, or between the different lines.

25

A bag for a fish cage preferably has at least three horizontal lines, one at the bottom, wherein the wall and bottom are connected, one at the top, where the bag is connected to the floating collar, and at least one arranged in between. Depending on the size of the bag, more horizontal lines between the upper and lower may be arranged. The additional lines described above attached to an upper connection

30

device, is preferably attached to the connection devices of one of the horizontal lines in the middle, and not the uppermost horizontal line.

By "floating collar" it is in this patent application meant devices at the surface of the sea holding the fish cage floating. This may be two pipes running in circle, wherein the pipes are arranged side by side, and fasten to each other by brackets. On the brackets there are often vertical bars making attachment for a handrail at the upper end. The bag is fastened to the inner side of the tubes, and the floating collar holds the bag floating.

By "sinker tube" it is in this patent application meant a device being lowered into the sea, and holding the bag dilated. The sinker tube has preferably about the same shape and diameter as one of the rings of the floating collar, and it is heavy so that the fish cage is held down and does not float up. The lower part of the bag, meaning the lower part of the wall, the bottom or the transition between wall and bottom, is fastened to the sinker tube, and the sinker tube will thus also make sure that the bag is dilated, and if the bag is made of a net, the mesh of the net will be dilated.

In another aspect, the invention relates to a connection device, as described above, to be used in a bag for a fish cage. The connection device has preferably at least four attachment members, arranged in pairs being opposite each other. By "opposite" it is not necessarily meant parallel, but the members should be arranged in such a way that two lines fastened to opposite members should continue in the same direction. When two parts of a vertical line is attached to the connection device in a pair of members, both lines should continue in vertical direction. Similarly for the horizontal line, attached to the other pair of members. However, the attachment members for the horizontal line may be slightly angled to each other, as the horizontal line is curved to create a circle.

When more than four lines should be attached to the connection device, the device preferably comprises more than four attachment members. The further members

should preferably be added in a third direction, or the direction wherein the line is to be fastened.

As said above, the material of the device should be sufficiently strong and preferably non-elastic, and the attachment members may be holes, slits, apertures, loops or the similar through the material of the connection device. The device is thus preferably a flat or curved piece of material with several holes, slits or apertures, and possibly having one or more bows or arcs raising above the material to create loops. As said above, the preferred material is metal, such as steel.

In the description relative terms such as front, top, center, bottom, side, lower, upper, downward, upward, outward, sideward, vertical, and horizontal etc. are all related to a fish cage having a bag as described above in a installed position in the sea i.e. when mounted and ready for use. Even though only exemplified for one side, it is to be understood that some features will correspondingly also apply for the opposite side of the device.

Reference throughout the specification to "one embodiment" or "an embodiment", "one aspect" or "an aspect" means that a particular feature, structure, or characteristic described in connection with an embodiment and/or aspect, is included in at least one embodiment of the subject matter disclosed. Thus, the appearance of the phrases "in one embodiment" or "in an embodiment" in various places throughout the specification is not necessarily referring to the same embodiment. Further, the particular features, structures or characteristics may be combined in any suitable manner in one or more embodiments.

The invention will in the following be described with an example given to illustrate the invention, and should not be used to interpret the invention, as it is defined in the enclosed claims, restrictive.

Example

The invention will in the following be described with the help of the enclosed Figures, showing a preferred embodiment of a fish cage and a device. The different parts of the figures are not necessarily to scale in relation to each other, as the figure is
5 merely for illustrating the invention.

The invention will in the following be described with reference to the enclosed Figures, where

Fig. 1 shows a fish cage according to prior art,

10 Fig. 2 shows an upper part of a fish cage according the invention,

Fig. 3 shows an enlarge part of Fig. 2,

Fig. 4 shows a lower part of a fish cage according to the invention,

Fig. 5 shows a connection device from a side, and

Fig. 6 shows a connection device from another side.

15

Figure 1 shows a fish cage according to prior art, having a floating collar 1 at the surface of the sea, a sinker tube 2 arranged at the bottom and a net bag 3 to keep the fish inside the fish cage. The net bag 3 comprises vertical walls and a conical bottom. Vertical lines 4, also referred to as lifting ropes, are running from the floating
20 collar to the bottom, and horizontal lines 5, also referred to as waistlines, are running around the circumference of the net bag. The vertical lines 4, are continuing along the conical bottom, and then they may also be referred to as cross ropes 12. Both the vertical lines 4 and the horizontal lines 5 are sewn to the material of the net bag 3, and crosses each other at cross points 8. In the shown fish cage, there are four
25 horizontal lines; one at the transition between wall and bottom, two in the middle and one at the upper part, hidden by the floating collar. A further line 6 is running from the lower horizontal line to the sinker tube, and another line 7 is running from an upper horizontal line 5, to the floating collar, to keep the net bag expanded and in position. Yet another line 9 is running from the sinker tube 2 to the floating collar 1, to
30 be used upon elevating the sinker tube 2.

Figure 2 and Figure 3 show a fish cage which, similar to prior art, have horizontal lines 5 running along the circumference of a bag 3, and vertical lines 4 running along the length of the bag 3, the lines are connected to the bag. The bag is attached to a floating collar 1 shown from underneath in Fig. 2. The vertical and horizontal lines
5 comprise several parts 4a, 4b; 5a, 5b; respectively, wherein an end of each line is attached to a connection device 10 in a cross point 8. In the shown embodiment, a connection device is arranged in every cross point, and thus the parts of each line 4a, 4b; 5a, 5b, is running from one connection device, to another. The parts are connected to the bag according to prior art, for instance by sewing. The fish cage
10 shown in figure 2, 3 and 4 further has an installation line 11, running from a horizontal line on the bag to the floating collar 1. The installation lines are used during installation of the bag and fish cage.

Figure 3 shows an enlarged detail of Fig. 2, and shows the attachment of the lines to
15 the the connection device 10. The shown connection device comprises six different attachment members, wherein two parts of the vertical line 5, two parts of the horizontal line 4, one line 7 to the floating collar, and one installation line 11 are attached to different attachment members. The parts of the horizontal line 5a, 5b are attached to members being opposite each other, and the parts of the vertical line 4a,
20 4b, are also attached to members being opposite to each other, but perpendicular to the members wherein the horizontal lines 5a, 5b are attached. The lines are connected at the cross point perpendicularly, and the direction of the lines continuous through the member. By attaching the lines to the device in this way, the parts of the line and the connection device create continuous lines along both the
25 circumference and length of the bag.

The parts of the horizontal line 5a, 5b and vertical line 4a, 4b lines, are treaded through a hole of the connection device, being the attachment member of the connection device, and turned back and fastened to itself. The ends of the lines are
30 fastened to the line itself, by splicing, and further by lacing, to create a loop running through the device. In the shown embodiment, the attachment of the line 7 and 11 running to the floating collar, are shown as different types of knots.

Figure 4 shows a corresponding view as Fig. 3, but at the transition between the wall and the conical bottom of the bag. The horizontal lines 5 and the vertical line 4 running along the wall, are attached to a connection device 10 as described above for Fig 3. According to prior art, and as shown in Figure 1, a cross rope 12 is running along the bottom of the bag, and in Fig. 4, the cross rope 12 is attached to the connection device 10 at a member being opposite to the member wherein the vertical line 4 is attached. In this way the direction of the vertical line 4, and the cross rope 4 will not be changed upon attachment to the device. Further, a line 6 running to the sinker tube 2 is also attached to the connection device, as well as an installation line 11.

In Figure 3 the connection device is arranged having two attachment members shown as holes facing upwards towards the floating collar 1, and in Figure 4 the connection device is arranged having two holes facing downwards away from the floating collar. This is because the different lines at each cross point may be attached to the attachment member of the connection device being most convenient, to avoid changing direction of the lines. This will be obvious to a skilled person.

Figure 5 and 6 shows the connection device 10 in detail, from two sides being perpendicular to each other. The shown connection device have six attachment members, 21, 22, 23, 24, 25 and 26, wherein the members are arranged in two pairs 21, 22; 23, 24 being opposite each other, and the pairs are perpendicular to each other. In the shown embodiment one pair 21, 22 are at two opposite sides of a central hole through the device, while the other pair 23, 24 are two separate holes at different ends of the device. In the embodiments shown in Fig. 2 and 3, the horizontal lines are attached to the members 21, 22, and the vertical lines are attached to members 23 and 24. The connection device further comprises a member 25 in an angle to the member 24, the member is shown as a protruding part of the device having a through hole wherein a line can be threaded. In the embodiment shown in Fig. 2 and 3 the attachment member 25 is facing upwards and the line 7, running to the floating collar, is attached to it. In the embodiment shown in Fig. 4, the

attachment member 25 is facing downwards and the line 11, running to the sinker tube is attached to it.

5 The connection device further comprises a sixth attachment member, shown as a loop 26 protruding from the pairs of members 21-24. In the shown embodiment the loop 26 is arranged above the central hole constituting member 21 and 22. In the figures the installation line 11 is attached to this member.

10 Even if the figures show a bag of a mesh material, the invention may be used on a bag of another material.

Claims

1. Bag (3) for a fish cage, having a number of lines (4, 5) running along the length and the circumference of the bag, the lines are connected to the bag,
5 **characterized** in that
- at least one of the lines (4) running along the length of the bag (3) comprise several parts (4a, 4b) being connected to each other by a connection device (10) to create a continuous line along the whole length of the bag, and
 - at least one of the lines (5) running along the circumference of the bag comprise
10 several parts (5a, 5b) being connected to each other by a connection device (10), to create a continuous line around the circumference of the bag,
- wherein the parts (4a, 4b) of the at least one line (4) running along the length of the bag are connected to the same connection device (10) as the parts (5a, 5b) of the at least one line (5) running along the circumference of the bag, the connection device
15 (10) is arranged at cross points (8) between the lines (4, 5).
2. Bag according to claim 1, **characterized** in that the connection device (10) has at least four separate attachment members (21, 22, 23, 24, 25, 26), wherein the ends of each line (4a, 4b, 5a, 5b) at the crossing point (8) is attached to a separate
20 member of the device.
3. Bag according to claim 2, **characterized** in that the attachment members are arranged in pairs being opposite each other.
- 25 4. Bag according to claim 1 or 2, **characterized** in that further lines are attached to the connection device.
5. Fish cage having a floating collar (1), **characterized** by having a bag (3) according to any one of claims 1-4, attached to the floating collar, for containing the
30 fish.

6. Device (10) for connecting parts (4a, 4b) of lines running along the length of a bag for a fish cage and parts (5a, 5b) of lines running along the circumference of the bag, according to any one of claims 1-4, **characterized** in that the device has a number of separate attachment members (21, 22, 23, 24, 25, 26), whereby each part of a line
- 5 (4a, 4b, 5a, 5b) is attached to an attachment member.
7. Device according to claim 6, **characterized** in that the attachment member is a hole, slit, aperture, loop or the similar.
- 10 8. Device according to claim 6 or 7, **characterized** in that the device is made of metal.

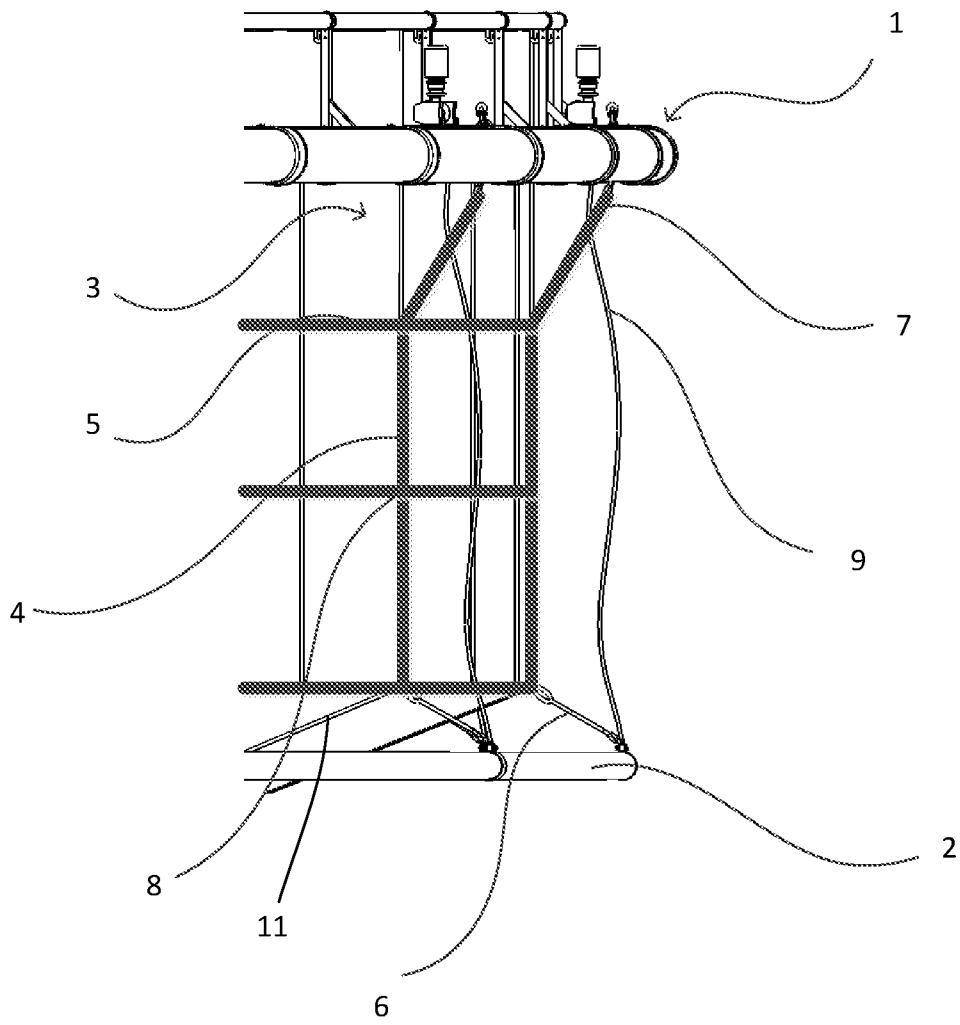

Fig. 1 – Prior art

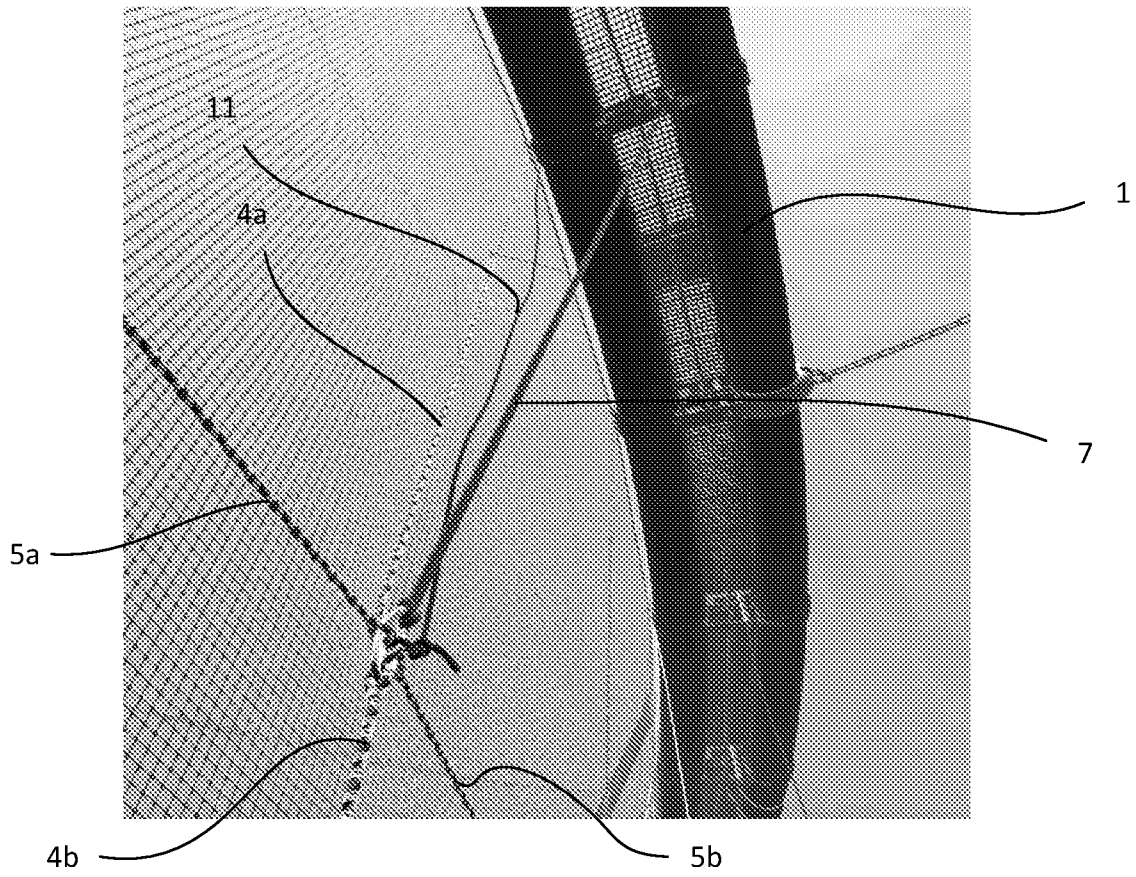

Fig. 2

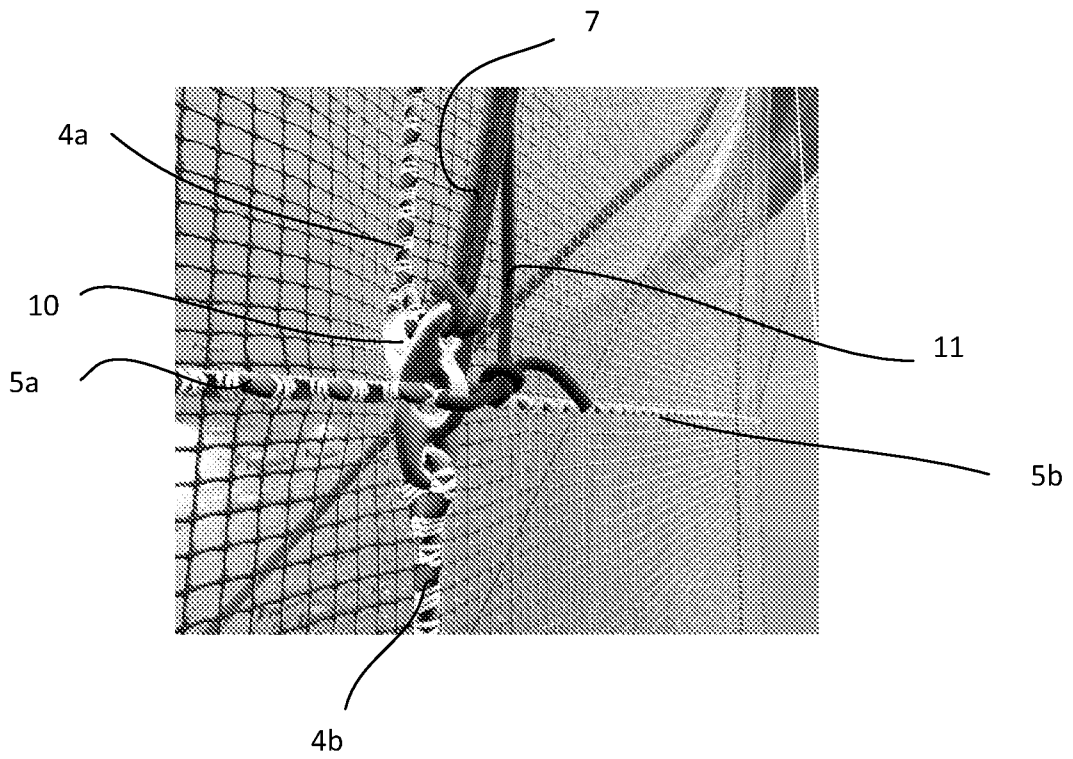

Fig. 3

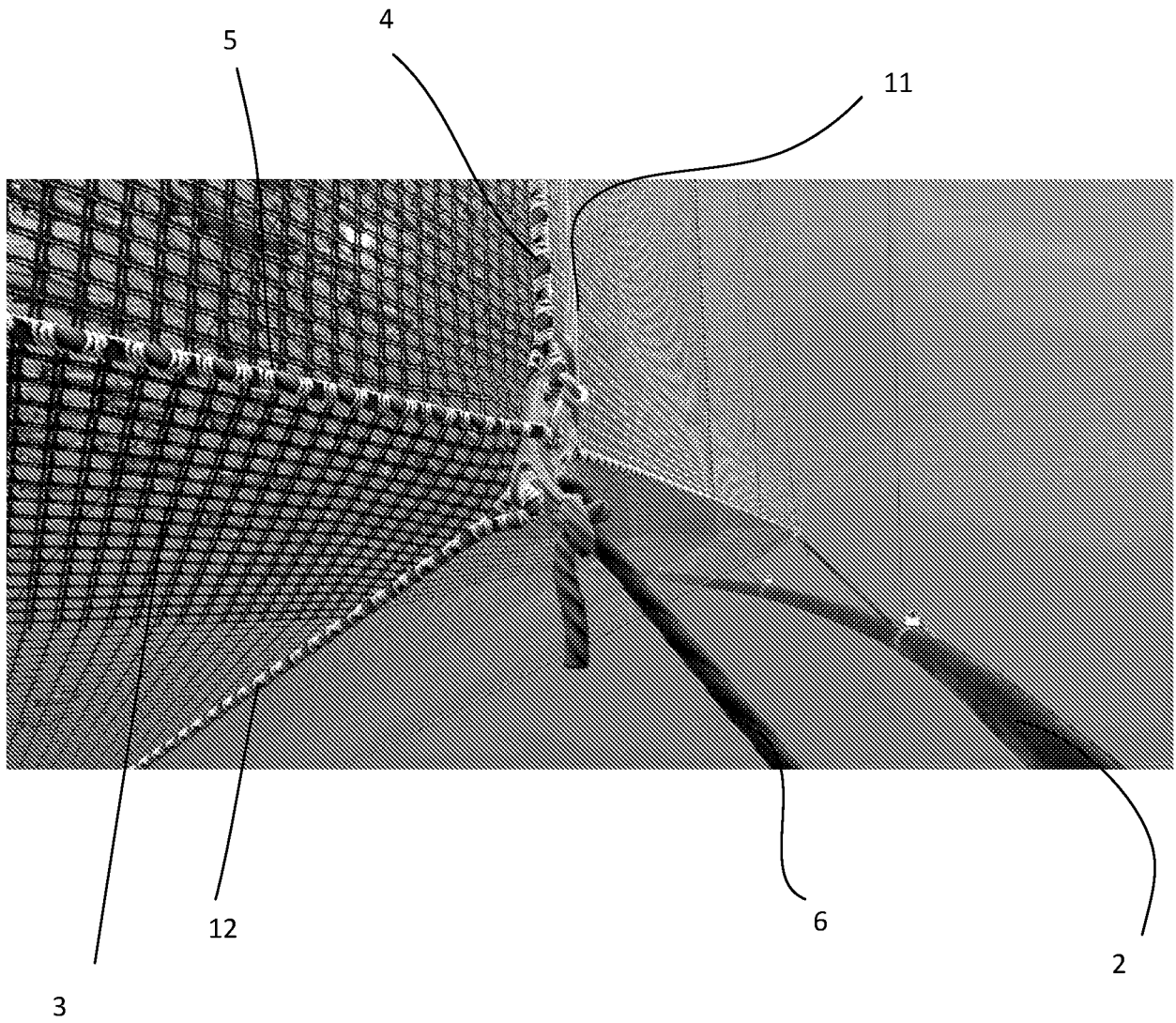

Fig. 4

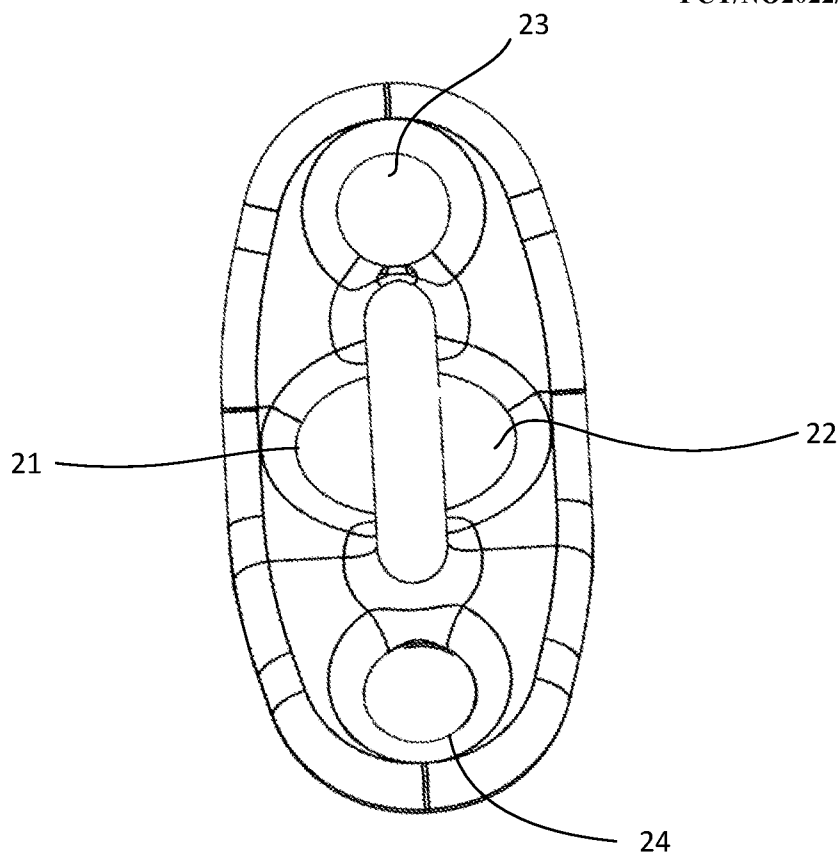

Fig. 5

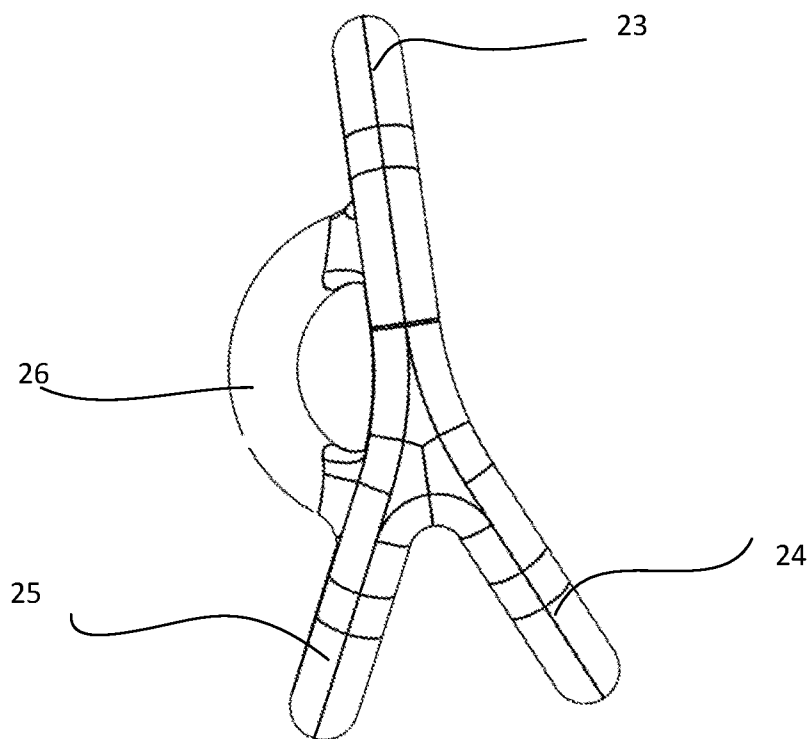

Fig. 6

INTERNATIONAL SEARCH REPORT

International application No
PCT/NO2022/050175

A. CLASSIFICATION OF SUBJECT MATTER
INV. A01K61/60 A01K75/00 B63H8/18 F16G11/04 F16G11/10
ADD.

According to International Patent Classification (IPC) or to both national classification and IPC

B. FIELDS SEARCHED
 Minimum documentation searched (classification system followed by classification symbols)
A01K B63B F16G B63H

Documentation searched other than minimum documentation to the extent that such documents are included in the fields searched

Electronic data base consulted during the international search (name of data base and, where practicable, search terms used)
EPO-Internal, WPI Data

C. DOCUMENTS CONSIDERED TO BE RELEVANT

Category*	Citation of document, with indication, where appropriate, of the relevant passages	Relevant to claim No.
X	WO 2017/075727 A1 (BUSCHMANN SCHIRMER WALTER FRANCISCO ALFREDO [CL]) 11 May 2017 (2017-05-11) page 5, paragraph 1 - page 8, paragraph 1; figures 1-6	1-8
X	NO 318 480 B1 (ATLANTIC CAGE SYSTEM AS [NO]) 29 March 2005 (2005-03-29) page 2, paragraph 24-32 page 6, line 6 - page 8, line 2 figures 1-2	1-8
X	US 2018/094696 A1 (STEPHENS ROD D [US]) 5 April 2018 (2018-04-05)	6-8
Y	paragraphs [0002], [0023] - [0026]; figures 1-2	1-5
	----- -/--	

Further documents are listed in the continuation of Box C. See patent family annex.

* Special categories of cited documents :

"A" document defining the general state of the art which is not considered to be of particular relevance	"T" later document published after the international filing date or priority date and not in conflict with the application but cited to understand the principle or theory underlying the invention
"E" earlier application or patent but published on or after the international filing date	"X" document of particular relevance; the claimed invention cannot be considered novel or cannot be considered to involve an inventive step when the document is taken alone
"L" document which may throw doubts on priority claim(s) or which is cited to establish the publication date of another citation or other special reason (as specified)	"Y" document of particular relevance; the claimed invention cannot be considered to involve an inventive step when the document is combined with one or more other such documents, such combination being obvious to a person skilled in the art
"O" document referring to an oral disclosure, use, exhibition or other means	"&" document member of the same patent family
"P" document published prior to the international filing date but later than the priority date claimed	

Date of the actual completion of the international search 11 November 2022	Date of mailing of the international search report 22/11/2022
--------------------------------------------------------------------------------------	-------------------------------------------------------------------------

Name and mailing address of the ISA/ European Patent Office, P.B. 5818 Patentlaan 2 NL - 2280 HV Rijswijk Tel. (+31-70) 340-2040, Fax: (+31-70) 340-3016	Authorized officer Kiyak, Ismail Utku
----------------------------------------------------------------------------------------------------------------------------------------------------------------------	-------------------------------------------------

INTERNATIONAL SEARCH REPORT

International application No
PCT/NO2022/050175

C(Continuation). DOCUMENTS CONSIDERED TO BE RELEVANT		
Category*	Citation of document, with indication, where appropriate, of the relevant passages	Relevant to claim No.
A	WO 2017/007335 A1 (MARINE BIO SOLUTIONS AS [NO]) 12 January 2017 (2017-01-12) page 11, line 14 - page 12, line 15; figures 1-3 -----	1-6
Y	WO 2014/189383 A1 (AQUALINE AS [NO]) 27 November 2014 (2014-11-27) cited in the application page 6, lines 4-21; figures 1-3 -----	1-5

INTERNATIONAL SEARCH REPORT

Information on patent family members

International application No

PCT/NO2022/050175

Patent document cited in search report	Publication date	Patent family member(s)	Publication date
WO 2017075727 A1	11-05-2017	CL 2015003239 A1 WO 2017075727 A1	05-08-2016 11-05-2017

NO 318480 B1	29-03-2005	NONE	

US 2018094696 A1	05-04-2018	NONE	

WO 2017007335 A1	12-01-2017	EP 3319419 A1 NO 340086 B1 WO 2017007335 A1	16-05-2018 06-03-2017 12-01-2017

WO 2014189383 A1	27-11-2014	AU 2014269197 A1 CA 2913123 A1 CL 2015003390 A1 EP 2999331 A1 NO 334957 B1 WO 2014189383 A1	26-11-2015 27-11-2014 09-12-2016 30-03-2016 04-08-2014 27-11-2014
